



Northeastern University



School of Law Library

DENNIS & CO., INC.
Law Book Publishers
251 MAIN STREET
BUFFALO, N.Y. 14203

INVESTIGATION OF CONCENTRATION OF ECONOMIC POWER

HEARINGS

BEFORE THE

TEMPORARY NATIONAL ECONOMIC COMMITTEE CONGRESS OF THE UNITED STATES

SEVENTY-FIFTH CONGRESS

THIRD SESSION

PURSUANT TO

Public Resolution No. 113 (Seventy-fifth Congress)

AUTHORIZING AND DIRECTING A SELECT COMMITTEE TO
MAKE A FULL AND COMPLETE STUDY AND INVESTIGATION
WITH RESPECT TO THE CONCENTRATION OF
ECONOMIC POWER IN, AND FINANCIAL CONTROL
OVER, PRODUCTION AND DISTRIBUTION OF
GOODS AND SERVICES

PART 2

PATENTS

AUTOMOBILE INDUSTRY
GLASS CONTAINER INDUSTRY

December 5, 6, 12, 13, 14, 15, and 16, 1938

Printed for the use of the Temporary National Economic Committee



UNITED STATES
GOVERNMENT PRINTING OFFICE
WASHINGTON : 1939

TEMPORARY NATIONAL ECONOMIC COMMITTEE

(Created pursuant to Public Res. 113, 75th Cong.)

- JOSEPH C. O'MAHONEY, Senator from Wyoming, Chairman
HATTON W. SUMNERS, Representative from Texas, Vice Chairman
THURMAN W. ARNOLD, Assistant Attorney General
- WENDELL BERGE, Special Assistant to the Attorney General
Representing the Department of Justice
 - WILLIAM E. BORAH, Senator from Idaho
 - WILLIAM O. DOUGLAS, Chairman
 - JEROME N. FRANK, Commissioner
Representing the Securities and Exchange Commission
 - GARLAND S. FERGUSON, Chairman
 - EWIN L. DAVIS, Commissioner
Representing the Federal Trade Commission
 - WILLIAM H. KING, Senator from Utah
 - ISADOR LUBIN, Commissioner of Labor Statistics
 - A. FORD HINRICHS, Chief Economist, Bureau of Labor Statistics
Representing the Department of Labor
 - HERMAN OLIPHANT, General Counsel
 - CHRISTIAN JOY PEOPLES, Director of Procurement
Representing the Department of the Treasury
 - RICHARD C. PATTERSON, JR., Assistant Secretary
Representing the Department of Commerce
 - B. CARROLL REECE, Representative from Tennessee
 - CLYDE WILLIAMS, Representative from Missouri
 - LEON HENDERSON, Executive Secretary

*Alternates.

CONTENTS

Testimony of—	Page
Arvedson, George C., chief of patent section, Automobile Manufacturers Association.....	301
Ball, Frank C., president, Ball Bros., Muncie, Ind.....	551,
556, 560, 561, 565, 567, 573, 576-582	582
Belknap, Charles B., executive vice president, Owens-Illinois Glass Co., Toledo, Ohio.....	656-666
Bracken, A. M., assistant treasurer and counsel, Ball Bros., Muncie, Ind.....	551, 554, 555, 573, 574, 577, 579-580
Coleman, S. A., Jr., former president of the Knappe-Coleman Glass Co., Port Isabel, Tex.....	610-619
Collins, I. J., president, Anchor Hocking Glass Co., Lancaster, Ohio.....	570-576
Curtiss, William H., vice president, Corning Glass Works, Corning, N. Y.....	637-638
Day, George, attorney at law, Detroit, Mich.....	619-624
Falck, Alexander D., chairman of the board, Corning Glass Works, Corning, N. Y.....	637-644
Farley, I. Joseph, patent counsel, Ford Motor Co., Detroit, Mich.....	256-284
Ford, Edsel, president, Ford Motor Co., Dearborn, Mich.....	256-285
Geer, Paul L., treasurer, Amsler-Morton Co., Pittsburgh, Pa.....	596-602
Goodrich, Edgar J., counsel for Hartford-Empire Co., Washington, D. C.....	395, 601, 602, 606, 667
Houghton, Amory, president, Corning Glass Works, Corning, N. Y.....	637-639, 644-656
Jaspert, William B., patent attorney, Pittsburgh, Pa.....	596
Kettering, Charles F., vice president, General Motors Corporation, Dayton, Ohio.....	340-361
Kingsland, Lawrence C., attorney, Obear-Nester Glass Co.....	624-636
Knudsen, William S., president, General Motors Corporation, Detroit, Mich.....	328-340
Levis, William E., president, Owens-Illinois Glass Co., Toledo, Ohio.....	474-491,
494-495, 497-522, 524, 528-535, 566-569	569
Macauley, Alvan, president, Packard Motor Car Co., Detroit, Mich.....	304-313
Martin, E. F., assistant secretary and assistant treasurer, Owens-Illinois Glass Co., Toledo, Ohio.....	518-519
McCallister, E. W., patent attorney, Pittsburgh, Pa.....	464-473,
554, 556-560, 578-580	580
McClure, Walter H., vice president and general sales manager, Hazel-Atlas Glass Co., Wheeling, W. Va.....	536, 547
McEvoy, James, director of patent section, General Motors Corporation, Detroit, Mich.....	328, 331, 332, 334-337, 361-371, 374-376
McNash, J. H., president, Hazel-Atlas Glass Co., Wheeling, W. Va.....	536-548,
561-566	566
Parham, Sidney F., resident patent attorney, Hartford-Empire Co., Hartford, Conn.....	396, 414, 436-464
Pease, A. M., assistant treasurer, Hartford-Empire Co., Hartford, Conn.....	603
Reeves, Alfred, vice president and general manager, Automobile Manufacturers Association, New York, N. Y.....	285-303
Safford, Arthur T., Jr., secretary and counsel, Hartford-Empire Co., Hartford, Conn.....	379-380,
387, 395-399, 401, 405-411, 418-420, 433, 603-610	610
Smith, F. Goodwin, president, Hartford-Empire Co., Hartford, Conn.....	379-433
Tibbets, Milton, vice president and patent counsel, Packard Motor Car Co., Detroit, Mich.....	304, 306, 307, 309-311, 315-328
Underwood, R. R., president, Knox Glass Associates, Oil City, Pa.....	582-595
Williams, Lloyd T., general counsel, Owens-Illinois Glass Co., Toledo, Ohio.....	491-493, 495, 496, 521, 523, 526

	Page
Statement of—	
Arnold, Thurman, Assistant Attorney General, United States Department of Justice, Washington, D. C.-----	254-256
Coe, Conway P., Commissioner of Patents, United States Patent Office, Washington, D. C.-----	372-374
Cox, H. B., chief counsel, Temporary National Economic Committee study for Department of Justice-----	377-379
Automobile industry:	
The policy of free licensing-----	257
The cross-licensing system-----	287
The license-royalty system-----	305
Glass Container industry:	
Control of an industry through patents-----	381
Patents in the glass-container industry-----	437
The largest glass producer in the world-----	474
Litigation and licensing-----	536
The fruit-jar producers-----	552
The control of the lehr-----	596
The elimination of a Texas independent-----	611
Refusal to license in Detroit-----	619
Record of an independent-----	625
The specialty glass field-----	640
Glass fiber and wool-----	657
Schedule and summary of exhibits-----	v-viii
Monday, December 5, 1938-----	253
Tuesday, December 6, 1938-----	315
Monday, December 12, 1938-----	377
Tuesday, December 13, 1938-----	435
Wednesday, December 14, 1938-----	489
Thursday, December 15, 1938-----	551
Friday, December 16, 1938-----	603
Appendix-----	669
Supplemental data-----	802
Index-----	835

SCHEDULE OF EXHIBITS

Number and summary of exhibits	Intro- duced at page	Appears in ap- pendix, page
90. List of patent threats received by the Ford Motor Co., 1926 to date.....	276	669
91. Constitution and by-laws of the Automobile Manufacturers Association, Inc.....	285	672
92. Members, officers, and directors of the Automobile Manufacturers Association, corrected to November 1938.....	286	682
93. National Automobile Chamber of Commerce cross licensing agreement form.....	287	(1)
94. Charter members of the National Automobile Chamber of Commerce, Mar. 19, 1913.....	287	(1)
95. Substitute cross license agreement form of the National Automobile Chamber of Commerce, Inc.....	296	(1)
96. First extension cross license agreement form of the National Automobile Chamber of Commerce, Inc.....	296	(1)
97. Second extension cross license agreement form of the National Automobile Chamber of Commerce, Inc.....	296	(1)
98. Third extension cross license agreement form of the Automobile Manufacturers Association.....	296	(1)
99. Automobile facts and figures of the Public Highway Association.....	302	684
100. Names of companies participating in the cross licensing agreements, 1915-25, 1925-30, and 1935-40.....	303	685
101. Growth of membership of the Automobile Manufacturers' Association for years 1913 to 1938, inclusive.....	303	691
102. Procedure covering patent section activities of General Motors Corporation revised to June 1, 1938.....	362	(1)
103. Procedure covering foreign patent and engineering liaison activities of General Motors Corporation revised to Apr. 1, 1937.....	362	(1)
104. Memorandum, "Reason for Taking out Patents", General Motors Corporation.....	364	691
105. List of patent-infringement suits litigated by General Motors Corporation.....	364	697
106. Schedule of litigation costs of General Motors Corporation.....	366	700
107. Statement of royalties paid, patents purchased, and royalties collected from Jan. 1, 1924 to Dec. 31, 1937, by General Motors Corporation.....	367	(1)
107-A. Statement of royalties and other payments made in connection with patents for the year 1937 by General Motors Corporation and its subsidiaries.....	367	(1)
108. Four screws.....	369	(1)
109. "Too Many Patents", a booklet showing blueprints and other patent data in connection with great number of patents on a single screw.....	369	(1)
110. History of the growth of the long pending patent application evil.....	374	701
111. Proposed patent legislation by General Motors Corporation.....	375	714
112. "Manufacture of Bottles," a pamphlet prepared by Department of Justice.....	379	736

¹ On file with the committee.

SCHEDULE OF EXHIBITS—Continued

Number and summary of exhibits	Introduced at page	Appears in ap- pendix page
113. Major inter-company relations in glass container industry, including supporting data.....	385	762
114. Schedule of royalty fees of the Hartford-Empire Co.....	399	763
115. Annual receipts from royalties and license fees, Hartford-Empire Co.....	399	764
116. Revision of figure 17 of "Exhibit No. 112" by F. Goodwin Smith of Hartford-Empire Co.....	403	765
117. Revision of figure 21 of "Exhibit No. 112" by F. Goodwin Smith of Hartford-Empire Co.....	403	766
118. License agreement between Hartford-Empire Co. and The Florida Glass Manufacturing Co. for the use of Miller feeder No. 75, dated Aug. 2, 1935.....	405	(1)
119. General agreement between Hartford-Empire Co. and Northwestern Glass Co., dated Aug. 1, 1933.....	406	(1)
120. Agreement, dated June 9, 1924, renewing license and lease No. HSF-20 between Hartford-Empire Co. and Laurens Glass Works.....	408	(1)
121. General Lehr agreement of Sept. 19, 1933, between Hartford Empire Co. and Whitall Tatum Co.....	410	(1)
122. Consolidated stacker and conveyor agreement between Hartford-Empire Co. and Owens-Illinois Glass Co.....	411	(1)
123. Letter, dated Aug. 26, 1932, from A. T. Safford, Jr., secretary of Hartford-Empire Co., to S. S. Searcy, an attorney in San Antonio, Tex., in contemplation of bringing suit against Three Rivers Glass Co.....	420	767
124. Memorandum, dated Mar. 26, 1928, re Hartford-Fairmont and Hartford-Empire history and policy.....	420	768
125. Memorandum of Feb. 18, 1930, re policy of Hartford-Empire Co.....	433	771
126. Copy of a letter from William E. Levis to R. H. Levis, dated Apr. 1, 1935, taken from the files of the former Illinois Glass Co. at Alton, Ill.....	482	780
127. Schedule of Owens-Illinois payments to, and receipts from, Hartford-Empire Co. for the years 1924 to 1937, inclusive.....	494	781
128. Copy of letter from W. E. Levis, president, Owens-Illinois Glass Co., to F. Goodwin Smith, president, Hartford-Empire Co.....	517	781
129. Copy of a letter, dated June 8, 1935, from A. L. Romine, Washington, D. C., to Owens-Illinois Glass Co. re contemplated erection of a glass factory.....	518	781
130. Copy of a letter, dated June 17, 1935, from legal and patent department of Owens-Illinois Glass Co. to A. L. Romine, Washington, D. C.....	518	782
131. Copy of a letter, dated June 25, 1934, from legal and patent department of Owens-Illinois Glass Co. to Mrs. Len Smith, Los Angeles, Calif.....	518	782
132. Copy of a letter, dated Dec. 10, 1934, to Sparks Construction Co., New York City, from legal and patent department of Owens-Illinois Glass Co.....	519	782
133. Copy of a letter, dated Aug. 2, 1932, from W. E. Levis, president of Owens-Illinois Glass Co., to R. H. Levis of Illinois Glass Consolidated Corporation, Alton, Ill.....	520	782
134. Memorandum, dated Apr. 12, 1930, from Henry W. Carter of Hartford-Empire Co. to W. E. Levis, president, Owens-Illinois Glass Co. re status of patent infringement suits brought by Hartford-Empire Co.....	522	784

¹ On file with the committee.

SCHEDULE OF EXHIBITS—Continued

Number and summary of exhibits	Introduced at page	Appears in appendix, page
135. Copy of general license agreement, in book form, dated Apr. 9, 1924, between the Owens Bottle Co., the Graham Glass Co., the American Bottle Co., the Charles Boldt Glass Co. and Hartford-Empire Co., Hartford-Fairmont Co.	534	(1)
136. Amendment of Feb. 9, 1925, of sec. 21, Joint Acquisition of Outside Rights, an agreement between Owens-Illinois and Hartford-Empire to share interests in inventions, patents, and patent rights.	534	(1)
137. Agreement, made Feb. 2, 1931, amending sec. 22 of Owens-Hartford general license agreement.	534	(1)
138. General license agreement, dated July 1, 1932, between Hartford-Empire Co. and Owens-Illinois Glass Co.	534	(1)
139. Suction inventions license agreement, dated July 1, 1932, between Hartford-Empire Co. and Owens-Illinois Glass Co.	534	(1)
140. Supplemental agreement, dated July 1, 1932, between Hartford-Empire Co. and Owens-Illinois Glass Co.	534	(1)
141. Certified copy of original agreements in files of Owens-Illinois Glass Co. between Hartford-Empire Co and Owens-Illinois Glass Co. as follows:		
1. General license, Hartford to Owens-Illinois, Oct. 1, 1935.		
2. General license, Owens-Illinois to Hartford-Empire, Sept. 30, 1935.		
3. Suction inventions agreement, Oct. 1, 1935, between Hartford-Empire and Owens-Illinois.		
4. Consolidated feeder and former license and lease from Hartford-Empire to Owens-Illinois, Oct. 1, 1935.		
5. Consolidated stacker and conveyor agreement, Oct. 1, 1935, between Hartford-Empire and Owens-Illinois.		
6. Consolidated Lehr agreement, Oct. 1, 1935, between Hartford-Empire and Owens-Illinois.	534	(1)
142. Letter-dated Dec. 13, 1938, from G. S. Quay, vice president and secretary, Hazel-Atlas Glass Co., to C. L. Terril, Department of Justice, containing record of royalty payments between Hazel-Atlas Glass Co. and Hartford-Empire Co.	543	787
143. General feeder license agreement, dated Mar. 25, 1933, between Hartford-Empire Co. and Ball Brothers Co.	554	(1)
144. Copy of letter, dated Sept. 1, 1932, from J. H. McNash, Hazel-Atlas Glass Co., to W. E. Levis, president of Owens-Illinois Glass Co.	562	788
145. Memorandum, dated Feb. 9, 1933, re Hartford-Empire Co.'s license to Hazel-Atlas Glass Co. to make fruit jars.	563	789
146. Memorandum, dated Dec. 13, 1930, from Henry W. Carter, vice president in charge of patent and license department, Hartford-Empire Co., to W. E. Levis, president, Owens-Illinois Glass Co., re general license agreement between Hartford-Empire and Owens-Illinois.	568	789
147. Letter, dated Aug. 17, 1933, from Roger M. Eldred of Hartford-Empire Co. to I. J. Collins, president of the Hocking Glass Co., Lancaster, Ohio, re sale of fruit jars.	572	791
148. Letter, dated Aug. 15, 1933, from F. C. Ball, president, Ball Bros. Co., Muncie, Ind., to R. M. Eldred of Hartford-Empire Co. re sale of packers ware sold by General Glass Co.; copy of an unsigned, undated letter re sale of Mason jars; and a letter, dated 8-5-33, from the Copps Co., wholesale grocers at Stevens Point, Wis., to Ball Bros Co. at Muncie, Ind. re "packer" is situation...	574	791

¹ On file with the committee

SCHEDULE OF EXHIBITS—Continued

Number and summary of exhibits	Introduced at page	Appears in appendix, page
149. Copy of letter, dated May 3, 1933, from F. C. Ball, president of Ball Bros. Co., to Goodwin Smith, president, Hartford-Empire Co., re sale of "Crack Shot" fruit jars made by the Three Rivers Glass Co.-----	579	792
150. Copy of an agreement, dated Aug. 23, 1933, between Hartford-Empire Co. and Lynch Corporation, a glass forming machine manufacturer.-----	604	(1)
151. Copy of a letter, dated Sept. 20, 1933, from Arthur T. Safford, Jr., secretary of Hartford-Empire Co., to T. G. Werbe, president of the Lynch Corporation, Anderson, Ind., re feeder licenses.-----	605	793
152. Amended agreement, dated Nov. 12, 1938, between Hartford-Empire Co. and the Lynch Corporation relating to patent rights applicable to glass forming machines.-----	606	(1)
153. Hartford-Empire analysis of financial statements.-----	607	794
154. Letter, dated Feb. 1, 1936, from A. M. Pease of Hartford-Empire Co., to George E. Day, Detroit, Mich., re proposition for glass plant in Detroit.-----	622	798
155. Copy of a letter, dated July 1, 1935, from W. A. Nester of Obear-Nester Glass Co., to T. C. Werbe, president of the Lynch Corporation, re furnishing of Lynch bottle forming machines.-----	634	798
156. Copy of a letter, dated July 1, 1935, from T. C. Werbe, president of the Lynch Corporation, to W. A. Nester of Obear-Nester Glass Co., re price and shipment of Lynch machine Model 10.-----	634	799
157. Copy of a letter, dated July 3, 1935, from W. A. Nester of Obear-Nester Glass Co., to T. C. Werbe, president of the Lynch Corporation, re taking out of license as prerequisite to shipping of Lynch machine.-----	634	799
158. Copy of a letter, dated July 8, 1935, from T. C. Werbe, president of the Lynch Corporation, to W. A. Nester of Obear-Nester Glass Co., re requirement of forming machine license to use Lynch machines.-----	634	800
159. Copy of a letter, dated Nov. 20, 1937, from Goodwin Smith of Hartford-Empire Co., to Amory Houghton, president of Corning Glass Works, re line of glassware called "Fryrock".-----	649	800
160. Contract between Owens-Illinois Glass Co. and Corning Glass Works, dated Oct. 28, 1938, for the formation of Owens-Corning Fiberglass Corporation.-----	657	(1)
161. Copy of a contract, dated Nov. 1, 1937, between Owens-Illinois Glass Co. and Societa Anonima Vetreria Balzaretta Modigliani, of Leghorn, Italy.-----	661	(1)
162. Letter, dated March 31, 1936, from R. D. Browns of Hartford-Empire Co., to T. C. Werbe of the Lynch Corporation, re misinterpretation of license contract between Hartford-Empire and the Lynch Corporation.-----	667	801
302. Automobile Manufacturers Association, Inc., statement of income and expense for year ended June 30, 1938, entered in record Feb. 28, 1939.-----		802
303. Letter, dated Jan. 9, 1939, from E. G. Ackerman of the Glass Container Association of America, submitting a "Survey of the Glass Container Industry," entered in record Feb. 28, 1939.-----		804
431. Memorandum, dated Feb. 21, 1939, from Lawrence C. Kingsland to T. N. E. C. regarding suggested changes in the patent laws, entered in the record May 1, 1939.-----		830

INVESTIGATION OF CONCENTRATION OF ECONOMIC POWER

MONDAY, DECEMBER 5, 1938

UNITED STATES SENATE,
TEMPORARY NATIONAL ECONOMIC COMMITTEE,
Washington, D. C.

The committee met, pursuant to adjournment, at 10:50 a. m. on Saturday, December 3, 1938, in the caucus room, Senate Office Building, Senator Joseph C. O'Mahoney presiding.

Present: Senators O'Mahoney (chairman), Borah, and King; Representatives Sumners and Reece; and Messrs. Arnold, Davis, Henderson, Patterson, Lubin, and Berge.

Present also: Department of Justice staff for Temporary National Economic Committee study—counsel, H. B. Cox (Special Assistant to the Attorney General); Joseph Borkin, Ernest Meyers, Charles L. Terrel, Benedict Cottone, Willis Rice, George Dession, Fowler Hamilton, H. C. Engelbrecht, Victor H. Kramer, J. M. Henderson, Monroe Karasik, Irving Glickfeld, Hyman Ritchin, David Clarke, Norman Bursler, and Seymour Lewis; also chief counsel for Federal Trade Commission Temporary National Economic Committee study, George W. Williams.

The CHAIRMAN. The meeting will please come to order.

This morning we are beginning the formal proceedings under section 3 (b) of the resolution by which this committee was created. That section reads as follows:

The Department of Justice, Department of the Treasury, Department of Labor, Department of Commerce, the Securities and Exchange Commission, and the Federal Trade Commission are directed to appear before the committee or its designee and present evidence by examination of witnesses or the introduction of documents and reports. The evidence presented by each of these agencies shall cover the subject matter of this inquiry which is within its administrative jurisdiction under existing law, or which may be assigned to such agencies by the committee. Each such agency is authorized to request the committee to issue such subpoenas as such agency may require for the attendance of witnesses and the production of documents and reports.

It will be observed from the reading of this section that it is within the jurisdiction of each of the departments to present its own case to the committee. The committee sits in judgment upon the evidence which is thus presented, and after the evidence has been presented the full committee will give consideration to the various facts which have been offered for study.

This morning the Department of Justice, which, with the Department of Commerce, the Federal Trade Commission and other agencies has been studying the effect of patent policies of the Government upon industry, and the effect of the use of patents upon industry, will present the first of these formal hearings.

I now call upon Mr. Thurman Arnold, member of the committee, who is the representative of the Department of Justice upon this committee, to explain what the purpose of the Department is this morning.

STATEMENT OF THURMAN ARNOLD, ASSISTANT ATTORNEY GENERAL, UNITED STATES DEPARTMENT OF JUSTICE, WASHINGTON, D. C.

Mr. ARNOLD. Mr. Chairman, I would like to make a statement for the record for the purpose of indicating the transition between the more general type of hearing which has just preceded and the more particular inquiries which the Department of Justice is about to commence.

The hearing which follows will be presented by the Antitrust Division of the Department of Justice. Mr. Hugh Cox, special assistant to the Attorney General, will conduct the examination in chief. It will deal with the use of patents.

In order to show the relationship of this hearing to the general introduction which has just been given by Mr. Lubin, Mr. Thorp, and Mr. Henderson, it is necessary to outline the traditional point of view of the Department of Justice, not as the point of view of any individuals, but as the attitude deriving from the character of the laws which it has administered for nearly 50 years.

I shall start my explanation by recalling two statements of Mr. Lubin. He said that American industry could not rest its distribution system upon the 2.7 percent of American families whose income is \$5,000 a year or more. He went further and said that American industry could not even rest its distribution system upon the 13 percent of families who get more than \$2,500 a year, since they total less than the population of the State of New York. We cannot produce for a nation the size of America and limit our distribution to the population of a State. There, in a nutshell, is our distribution problem.

The antitrust laws represent an approach to that problem based on the conviction that prices must be brought within the reach of purchasing power for free and independent enterprise to do the job. Mr. Lubin pointed out the tremendous revival of industry which would occur if the five and one-half million families not on relief whose incomes have been about \$1,200 a year or less should receive only \$2.25 a day more.

Of course, there is more than one way of giving them that \$2.25. Incomes may be raised by direct Government subsidy. Another method involves laws raising wages or, as in the case of farmers, the prices of goods they sell. A third is by lowering prices to bring industrial goods and services within the reach of purchasing power. There is no single method which should be rigidly prescribed; all may be useful in their places. As a matter of fact, if industry cannot bring its prices within the reach of purchasing power, it is difficult to see how industrial activity can be maintained without Government spending.

The third method—that of increasing the distribution of goods through competitive prices—is the one upon which the antitrust laws lay emphasis. Therefore, it is that method which will be stressed in that part of the hearings presented by the Department of Justice.

Before going further, I must emphasize two points:

First. In this investigation the Department of Justice is working for this committee, and, while we plan to be complete and thorough,

it must always be remembered that what we present always must be subject to further study by the committee. We do not profess to speak for the committee.

Second. Because of the title of "Monopoly" often given this committee, there has arisen some confusion which has tended to confuse the work of the Department of Justice with that of the committee. Of course, the committee is not engaging in enforcement activities of any character. The Department is so engaged, but this work has no relation to the committee's program, except, of course, as the committee may desire to avail itself of our experience.

The instruments by which the Antitrust Division seeks to accomplish its objectives are the antitrust laws. They emphasize decentralization. They have been customarily referred to as an antimonopoly policy. A more accurate description would be to call it a policy against such restraints of trade as unreasonably hamper the free flow of goods in commerce at competitive prices. It is based upon the assumption that free and independent enterprise is able to distribute goods with efficiency, provided that small groups without public responsibility are prevented from eliminating competition and exercising arbitrary power over prices and distribution.

In pursuing these objectives, antitrust enforcement offers an outstanding advantage. That advantage is the fact that the traditional case-by-case method permits us to take up problems, industry by industry, and situation by situation. Mr. Thorp, in his testimony last Friday, vividly demonstrated the tremendous variation between industrial patterns. The problems of the building trades are not the problems of the movies. The solution of milk tells us nothing about problems of steel. Under the case-by-case procedure of the Department of Justice, each business practice may be examined with respect to the particular interest and individuals involved.

The presentation by the Department must necessarily cover two fields: First, substantive antimonopoly laws; and, second, procedure and administration. The inquiry into the latter should logically be postponed until after the substantive problems have been explored, and only a brief mention of the scope of the procedural inquiry can be made at this time. It must include:

(1) An examination into the deficiencies of administration, involving determination of the size and type of organization required for adequate enforcement;

(2) An examination of how the case-by-case method may be utilized to clarify the antitrust laws with respect to individual businesses or geographic areas—to the end that each businessman may have the guide he has so often requested as to what concerted action is lawful in his own industry. Here we hope to find the answer to the questions most frequently asked of the Department: (a) What is a monopoly? (b) How may antimonopoly policy be so administered as not to interfere with industrial efficiency? and (c) How may scrambled eggs be unscrambled?

(3) An examination of how observance of the antitrust laws by normally law-abiding businessmen may be obtained—those businessmen who now are so often compelled by the aggressive tactics of others to violate the law in order to survive; and

(4) An examination of how the antitrust laws may have a constructive application, through consent decrees and systematic co-

operation with legislative committees, in cases where certain combinations may be found to be in the public interest.

In carrying out our first task, the task that relates to the substantive law of monopoly and the concentration of power it is necessary to select a starting point. There is no inevitably logical starting point. However, we are beginning with patents for the following reasons:

A patent is a legal monopoly granted on the theory that it will promote the progress of science and useful arts. The law at present affords to the patent owner such a wide choice in exploiting a new industrial art that it offers wide opportunities for the restraint of trade. These opportunities are facilitated by the technical complexity of patent law, the costs of litigation, and the ever-present problem of drawing a sound line between the legitimate use of patents and the uneconomic extensions of that privilege.

In submitting evidence on patent practices we have selected automobiles and glass not with an intent to single out those industries, but because they illustrate typical situations which are common throughout the industrial field. Moreover, they involve products which are of interest to every consumer.

And with that statement, Mr. Chairman, I will turn the presentation of testimony of witnesses over to Mr. Cox.

The CHAIRMAN. Mr. Cox, will you be good enough to call your first witness?

Mr. COX. Mr. Ford and Mr. Farley, will you come forward?

Mr. Chairman, with your permission I should like to have two witnesses sworn at the same time, Mr. Edsel Ford and Mr. I. J. Farley.

The CHAIRMAN. Do you and each of you solemnly swear that the testimony you shall give in this proceeding shall be the truth, the whole truth, and nothing but the truth, so help you God?

Mr. FORD. I do.

Mr. FARLEY. I do.

The CHAIRMAN. Be seated.

TESTIMONY OF EDESEL FORD, PRESIDENT, THE FORD MOTOR CO., DEARBORN, MICH., AND TESTIMONY OF I. JOSEPH FARLEY, PATENT COUNSEL, FORD MOTOR CO., DETROIT, MICH.

Mr. COX. Mr. Ford, will you give your name and address to the reporter?

Mr. FORD. Edsel B. Ford, Ford Motor Co., Dearborn, Mich.

Mr. COX. Mr. Farley, will you do the same?

Mr. FARLEY. I. Joseph Farley, Detroit, Mich.

Mr. COX. Mr. Ford, you are the president of the Ford Motor Co., are you not?

Mr. FORD. I am.

Mr. COX. Also of the Lincoln Motor Car Co.?

Mr. FORD. I am.

Mr. COX. As president you are familiar with the policy which those two companies pursue in regard to the patents?

Mr. FORD. Yes, sir.

Mr. COX. Mr. Ford, will you tell us whether those two companies ever apply for and take out patents on inventions?

Mr. FORD. We do.

Mr. Cox. What is the primary reason for your companies taking out patents on inventions, Mr. Ford?

Mr. FORD. Our primary reason for taking out patents is to protect ourselves from possible infringements—our policy of taking out patents is to protect ourselves from the possibility of being attacked later when we have developed an art of some kind that we use in our product and an individual who may claim that we have infringed some device or idea of theirs may start an action against us, and we found it to be a good policy to cover every new device that we felt could be.

THE POLICY OF FREE LICENSING

Mr. Cox. Mr. Ford, after your company acquires a patent, is it your practice to grant a license under that patent to others engaged in the automobile industry?

Mr. FORD. We will grant a license to anyone who asks for it.

Mr. Cox. And do you ever charge royalty fees for that license?

Mr. FORD. No, sir; we do not.

Mr. Cox. In other words, when you have acquired a patent on an invention you, in effect, dedicate that invention to the public. Is that a fact?

Mr. FORD. For those that want to use it as it applies to their requirements.

Mr. Cox. Has the Ford Motor Co. at any time in its history ever collected royalties?

Mr. FORD. In one instance.

Mr. Cox. How long ago was that, Mr. Ford?

Mr. FORD. This license agreement was dated the 9th day of June, 1911. Do you want the name?

Mr. Cox. No.

Mr. FORD. That was the only instance where we granted a license and collected the royalties.

Mr. Cox. Since 1911 there has been no other instance of that kind?

Mr. FORD. That is right.

Mr. Cox. Can you tell us, Mr. Ford, in a general way, what form your license agreements take, by that I mean, are they long documents?

Mr. FORD. Usually they are very brief letters, just giving authority and outlining to the person taking out the license the authority to use the license under a certain number and without restriction.

Mr. Cox. The license agreement contains no restrictions formally of any kind?

Mr. FORD. That is quite right.

Mr. Cox. Mr. Ford, do persons ever use your patents or inventions, I should say, which are covered by your patents who have not obtained a license from you?

Mr. FORD. Yes.

Mr. Cox. Is it your policy to sue a person who does that?

Mr. FORD. It is not.

Mr. Cox. Has this always been the policy of the Ford Co.?

Mr. FORD. With the exception of one instance, we started one suit, I believe.

Mr. Cox. How long ago was that, Mr. Ford?

Mr. FORD. 1909.

Mr. Cox. Since that time there have been no suits for patent infringement in which the Ford Co. has been a plaintiff. Is that correct?

Mr. FORD. That is correct.

Mr. COX. I take it, then, Mr. Ford, that your company is not interested in making money by pursuing a litigation policy on your patents.

You said a moment ago that the Ford Co. does apply for a patent and has acquired patents. Have any of those patents covered devices which have been used generally in the motor-car industry?

Mr. FORD. In the early days they were.

Mr. COX. Do you think of any in particular of that character?

Mr. FORD. I can think of one in the patent which covered the universal joint and torque tube drive. It has to do with the rear axle construction.

Mr. COX. That was used by the industry generally.

Mr. FORD. It was used. I don't know that I could say generally, but to a great extent.

The CHAIRMAN. By that you mean it was used by some competitors.

Mr. FORD. Yes, sir.

Mr. COX. And you collected no royalties on that patent?

Mr. FORD. No royalties.

Mr. COX. Mr. Ford, is the Ford Co. ever sued for patent infringements?

Mr. FORD. Are they sued?

Mr. COX. Yes.

Mr. FORD. Yes, sir; they are, quite frequently.

Mr. COX. Can you give us any idea as to how many times the company has been sued?

Mr. FORD. We have been sued 60 times; we have been threatened 346 times; actual suits have been started against us 60 times.

Mr. COX. How many such suits are pending now?

Mr. FORD. Thirteen.

Mr. COX. And you say you have been threatened with suits for infringements some three-hundred-odd times?

Mr. FORD. Yes; 346 times, up to date.

Mr. COX. That was throughout the history of the company?

Mr. FORD. Mr. Farley says it is from 1926 to the present time.

Mr. COX. From 1926 to the present time. Can you give us any idea, Mr. Ford, as to the range of devices which you have been accused of using which infringe other persons' patents?

Mr. FORD. I can, sir. Do you want me to read them over?

Mr. COX. Just indicate in a general way. Perhaps Mr. Farley can do that.

Mr. FARLEY. I would say we are sued on everything from milk wagons to cafeterias, including many parts of the automobiles as well as manufacturing processes used throughout the plants and all departments of the plants.

Mr. COX. Mr. Ford, when a new device is presented to you and suggested that it be used by the company, what steps do you take to discover whether the use of that device will infringe someone's patent?

Mr. FORD. Did you mean a device that our own people develop?

Mr. COX. Well, yes.

Mr. FORD. We make a complete search through the Patent Office to see whether there are any patents which come anywhere near the device that we have created.

Mr. COX. What is your policy with respect to the suits which are brought against you for patent infringement? Is it your practice to litigate those?

Mr. FORD. We litigate every suit that we are threatened with or that has been brought against us.

Mr. COX. Is it your policy to settle those suits by compromise?

Mr. FORD. Not generally.

Mr. COX. How many of the suits, can you tell us, that you mentioned before, have been won by the Ford Company? If you can't tell us, perhaps Mr. Farley can.

Mr. FORD. All but one.

Mr. FARLEY. Of the 60 suits actually brought against the Ford Co., there has been only one suit that was lost and finally decided against the Ford Co. in the court of last resort.

Mr. COX. Mr. Ford, did your company ever take a license under the invention, under a patent held by someone else?

Mr. FORD. Yes, sir.

Mr. COX. Is it the practice of the company to accept a license when royalties are charged?

Mr. FORD. No, sir; we do not pay royalties.

Mr. COX. You do not pay royalties. If the holder of a patent does not wish to extend to you a license royalty free, what steps do you take, if any, to obtain the use of the invention that is covered by the patent?

Mr. FORD. If the device is one that we are very much interested in and wish to use in construction, we, in several instances, encourage the man that has developed this device to manufacture that article, and then we purchase it from him, or we encourage him to license some other manufacturer to make it, and we would purchase it from them.

Mr. COX. Did you ever give an inventor or patent holder who is in that situation any assistance?

Mr. FORD. We have in several instances helped them get started, helped finance them, loaned them machinery and so forth.

Mr. COX. Will you explain, briefly, what the reason is for that policy on your part, of not accepting a license which involves the payment of royalties?

Mr. FORD. We feel a patent should be worked, and we as a matter of policy haven't encouraged inventors to bring in a patent to us that we might be interested in and then just sit back and take the royalty of this patent without putting the patent to some constructive use. Therefore we felt that if the man having the patent could get into the manufacturing business and use his patent for his benefit, it would encourage him in using his ingenuity and it would also be a constructive way of utilizing this device.

Mr. ARNOLD. You are also encouraging competition by that method, aren't you, Mr. Ford?

Mr. FORD. I feel so.

Senator KING. In a number of those instances has your suggestion been carried out?

Mr. FORD. That it has been accepted in that way?

Senator KING. Yes.

Mr. FORD. Oh, yes.

Senator KING. So that a new industry would be developed?

Mr. FORD. A new manufacturer, a new parts maker, or a person who was a very small source of supply might be developed into a much larger.

Representative SUMNERS. May I ask this one question: Why don't you pay the inventor some royalty, why are you not willing to pay the inventor some royalty, and why as a different policy do you have somebody else manufacture the article?

Mr. FORD. We feel that the inventor, from a constructive standpoint, will benefit more from the patent if he sees that it is manufactured and lives with the patent and helps to develop it through manufacturing processes. He may create the patent and then if he licenses somebody he forgets it except for his ability to collect the royalties; but if he starts to manufacture this patented article and lives with it, we feel that he will be much more apt to develop that and improve it for his benefit and for ours.

Mr. ARNOLD. And I take it that you do not desire the type of exclusive control over the arts of the industry which the other method would give you?

Mr. FORD. We don't desire it, Mr. Arnold.

Representative REECE. Your company maintains facilities for making a study of and determining the usefulness of patents which might be submitted to you by investors?

Mr. FORD. We have no research department as such. We have our engineers who check over and investigate things that are submitted, and our patent attorneys here in Washington cooperate to that end.

Mr. OLIPHANT. These suits for infringement brought against you, Mr. Ford, are most of those suits brought by men who have not tried to manufacture their invention?

Mr. FORD. I should say in most instances.

Mr. OLIPHANT. Have you had any important suits brought by people who are trying to manufacture their inventions, or are engaged in manufacturing their inventions?

Mr. FORD. I think Mr. Farley could answer that, if you will permit it.

Mr. OLIPHANT. Are there any outstanding examples of that situation?

Mr. FARLEY. I would say that 95 percent of the suits brought against the Ford Co. are suits in which the holder of the patent is not engaged in manufacturing, and in the very large majority of cases has never been engaged in manufacture.

Mr. OLIPHANT. A little more information about the 5 percent, then. What type are the outstanding examples of that?

Mr. FARLEY. I don't think there are any outstanding examples. There is only one case that I can recall offhand without consulting all the records in which suit was brought by a concern which was actively engaged in business, but their business was that of licensing companies to use a process on the basis that every pound of material used by the licensee in carrying out the process carried with it a royalty of a very substantial amount, of so much per pound.

Mr. OLIPHANT. Thank you.

Mr. PATTERSON. Mr. Farley, along this same line, what is the source of these threats?

Mr. FARLEY. Well, I don't quite understand what you mean, "What is the source of these threats?" Just exactly what do you mean, sir?

Mr. PATTERSON. Are they made chiefly by your competitors in the auto industry, or by individuals?

Mr. FARLEY. I would say substantially by individuals, none from our competitors in the automobile business.

The CHAIRMAN. You may proceed, Mr. Cox.

Mr. COX. Turning for a moment to the policy which you describe, of asking the inventor either to manufacture his device or to license someone else to manufacture it, would it be accurate to say that one reason you do that is because you wish to make sure that the device is, in fact, a device which is capable of practical application and not merely a paper patent?

Mr. FORD. I should say that is quite true.

Mr. COX. In other words, it is the attitude of your company that the development of a device and its actual application to the art in a practical way does promote the progress of science and useful arts, but the issuance of a mere paper patent on which royalties are collected does not?

Mr. FORD. I believe that very definitely. That is our policy.

Mr. COX. In the licenses which you take under other persons' patents, is it your policy to accept a license if any restrictive provisions are imposed? And by "restrictive provisions" I mean restricting the amount of your production in connection with which you may use the patent, or restrictions as to resale price, or anything of that sort?

Mr. FORD. We would not take licenses under those circumstances. We would want a free hand.

Mr. COX. You neither take nor grant licenses of that kind?

Mr. FORD. That's right.

Dr. LUBIN. Mr. Ford, is the Ford Motor Co. ever offered any patents on the basis as that described by Mr. Cox?

Mr. FORD. With restrictions? I can't recall, offhand, but I have that impression.

Senator KING. I understood from your answer, as well as that of Mr. Farley, that tenders had been made by the patentees or alleged patentees, which were accompanied by restrictions, and you refused to acquire them with those restrictions. You want a free hand.

Mr. FORD. That is our policy. We want a free hand, sir.

Mr. COX. In a situation such as you have described, where the owner of the patent has undertaken production of the patented article or licensed someone else to produce the patented article, will you indicate briefly the basis on which you purchase that patented article for use in the manufacture of your cars?

Mr. FORD. The article is produced by some source. That source goes to our purchasing department and a stipulated price is made for the article which is to include any royalties that have to be paid, or any additional remuneration that has to be collected because of the benefit of the patent. It is all included in our purchasing price.

Mr. COX. In agreeing on price with the manufacturer, then, it is not the policy of the company to refuse to make any allowance for royalties to the inventor?

Mr. FORD. I would not say so.

Mr. Cox. I think you said a moment ago in response to a question by a member of the committee that your company carried on research for development work.

Mr. FORD. Yes, sir.

Mr. Cox. You don't have a separate department for that, however?

Mr. FORD. Not as such.

Mr. Cox. In carrying on that work, is it the purpose or intent of the company at all to develop inventions for the purpose of acquiring patents on them? Is that the purpose?

Mr. FORD. No, sir; it is not. Our intention is to develop the art of the manufacture of motorcars.

Mr. Cox. Do you have any opinion as to whether, if it were not possible for a company to acquire a patent on an invention, that same work would nevertheless be carried on?

Mr. FORD. I feel quite definitely it would be carried on. It would have to be, for progress.

Mr. Cox. What kind of arrangements do you have with respect to employees who have inventions?

Mr. FORD. Employees that create inventions of their own origin and are made on company's time are assigned to the Ford Motor Co. We pay them no fee for that invention. We feel that they should be well paid, and I think they are well paid, and anything they contribute in the way of invention on Ford Motor Co.'s time should be assigned to the Ford Motor Co. They have done that and that has been the policy, and it seems to be satisfactory.

Mr. Cox. Mr. Farley, I think I should like to ask you one or two questions now.

You do not devote all of your time to the Ford Motor Co., is that correct?

Mr. FARLEY. That is quite correct. I have represented, before directly taking over the Ford litigation (the practice that I was engaged in in New York), what may be termed the poor inventor and the small manufacturing companies. I still number among my clients a number of inventors and smaller companies.

Mr. Cox. You heard the answer Mr. Ford gave a moment ago, when I asked him whether, if it were not possible for his company to obtain a patent, his company would carry on its research and continue its work. I now ask you whether you have any opinions as to what effect the absence of a patent law would have on the work which is carried on, not in a large corporate organization such as Mr. Ford's but by individual inventors or small companies?

Mr. FARLEY. I would say, in my opinion, the absence of a patent system for the small company and the small inventor would be quite a detriment. Unquestionably there are a large number of cases where the small company has perfected a very good device that it in many cases would be impossible for them to get capital interested in to manufacture that device if capital were not assured there was some sort of patent protection which could be relied upon during the infancy of the company.

Mr. Cox. Is it also your opinion that the possibility of a patent acts as a spur to the individual inventor?

Mr. FARLEY. Well, I am afraid my opinion in that respect is perhaps a little bit different from the average patent lawyer's.

I personally feel that the majority of the worth-while, the important, contributions are made by men—engineers—who are more concerned with doing a good job than they are with their eye on the patent. I feel we don't get most of our progress from what we call patent-minded men as much as we do from men who are looking forward to promoting progress.

Representative SUMNERS. At that point I would interrupt to make an inquiry. These engineers are, however, usually on the pay roll of somebody, and they don't have to live off public service entirely?

Mr. FARLEY. I would say that is true in the majority of instances. It seems to me from what I have seen of the many patents I have had to consider, particularly in connection with the automotive industry, that the most important contributions have come from the men who have been devoting their lives to that work, and naturally, if they are competent men, they are snapped up by the automotive companies. A competent engineer has no difficulty getting a position in which he is paid a very excellent salary, and when he gets that his life work is the promoting of his job and bringing out the best product he can.

Representative SUMNERS. Does he get his start, however, from being patent-minded or from having a good job as an engineer?

I won't go further with that.

Mr. FARLEY. That would be a matter of considering a number of individual cases before you could really answer that.

Representative SUMNERS. I understood you were expressing opinion on that particular point. That is the reason I asked the question.

Mr. FARLEY. I feel that because I know of the large numbers of patents that have been granted to the various engineers. Most of the contributions come from the engineering department of the corporations who are engaged in the actual manufacture of automobiles.

Representative SUMNERS. One other question, to make it clear: Is it a fact, however, that most concerns engaged in the manufacturing business have engineers who are devoting a good deal of their time to improving processes which are patentable?

Mr. FARLEY. I think it is unquestionably true. I don't think any company today could exist if it didn't have that policy of improving its product by any possible means of development work.

The CHAIRMAN. Is there any difference, Mr. Ford, in the manner in which you compensate an employee of yours who is assigned to research work and one who, not having been so assigned, happens to conceive an idea which is capable of being written into a patent?

Mr. FORD. I don't know of any instance where that type of individual has come to light. Usually the procedure in the various departments where development is progressing from day to day is that those are the men who usually create new ideas because of their familiarity with the job and their work from day to day.

The CHAIRMAN. Do I correctly understand your testimony, that your employees' salaries are fixed upon the basis of the work that they are required to do, and any contribution that they make by way of invention does not result in any special compensation for that particular act?

Mr. FORD. It may not at that particular instant, but we naturally would be anxious to reward a man through his salary.

The CHAIRMAN. If an employee by his suggestion should indicate competence to aid in the development of the automotive industry, you would naturally feel he was worthy of promotion, yes; but I am speaking of the immediate suggestion.

Mr. FORD. I don't know of any instance of that kind, Senator.

The CHAIRMAN. May I ask you also whether this policy—

Mr. FORD (interposing). There was one instance.

The CHAIRMAN. Naturally, I was speaking only of the general rule. I was about to ask you whether this policy of yours, of declining to accept a license upon any invention, has caused the Ford Motor Co. to lose the use of any material device on a motorcar.

Mr. FORD. I don't feel so. I don't feel we have lost anything by that.

The CHAIRMAN. Do you feel that you have benefited by this policy?

Mr. FORD. We think the policy is a good one.

The CHAIRMAN. As I understand your testimony it is to the effect that if you were to accept licenses and manufacture the devices yourself and handle them yourself, that would tend to deprive the inventor of that constant contact with the patent which would enable him to develop it, and might be productive of litigation and disturbance of one kind or another.

Mr. FORD. That is correct.

The CHAIRMAN. Thank you very much, Mr. Ford.

Senator KING. Have you any instances of cases in mind where, when you have refused to purchase a patent and have suggested that the patentee develop it himself and secure capital, and you have aided him in accomplishing that end, he has gone forward and developed the art, or, rather, the particular mechanism or patent, to his own advantage as well as to the advantage of the public?

Mr. FORD. Yes, sir; there are several instances of that kind.

Senator KING. Would you say, generally, that those inventions that have been brought to your attention which have had merit, which you have declined to purchase but on which the patentee has gone forward and developed them, have resulted in greater benefit to him and to the public than if you had acquired it?

Mr. FORD. I think so.

Mr. COX. One question along the line Senator King was following I should like to ask. In those cases where you have assisted an inventor to put his patent into actual production, have you ever attempted to prevent the inventor or his licensee from selling that device to your competitors in the automobile industry?

Mr. FORD. No, sir; we haven't.

Mr. ARNOLD. Your's has been a matter of public policy rather than year to year figuring of income, hasn't it?

Mr. FORD. Yes, sir; that is right.

Mr. OLIPHANT. Might I ask Mr. Farley this question: Your opinion was that, speaking percentagewise, the mass of significant inventions are the result of organized engineering effort. As I understand, you were speaking percentagewise?

Mr. FARLEY. Yes.

Mr. OLIPHANT. There have been, in absolute numbers, a great many very significant inventions that have been the result of individual effort.

Mr. FARLEY. I think that is unquestionably true. I would say that, while I believe by far the most important contributions have come from the men who were really more concerned in turning out a good job than in getting a patent eventually, unquestionably there have been many contributions of value which have come from men who would not have done their work had they not had before them at some time the hope of the reward of a patent.

Mr. OLIPHANT. Do there occur to you any examples of patents that are the result of individual or organized effort?

Mr. FARLEY. I would prefer to check that by research into the records on that matter.

Senator BORAH. Mr. Farley, you have evidently had a vast amount of experience with the patent laws. Have you any suggestion you could make to the committee with reference to change in the patent laws for public good?

Mr. FARLEY. That matter, Senator, I feel, is one that requires a great deal of careful thought and study. All of us men in the Patent Bar have our own ideas as to our own pet schemes, and I would prefer at this time to avoid making specific suggestions. It is a matter I would prefer to discuss with perhaps the members of the committee here and others who may have different views, so that they might be harmonized.

Of course, we feel, gentlemen, that something certainly should be done to avoid the long pending application, kept for many years in secrecy in the Patent Office. We feel that something should be done to take care of the situations where a man files a patent application, in many instances, on a device that has no commercial utility, and then sees the product of practical manufacture and amends his claims in the Patent Office to cover the practical device which has recently come into being as the result of a development of a person who knew nothing about the patent. We have had that in many of our own cases where, after the Ford Co. produced a device on the market, the inventor or pseudo-inventor, let's say, the patentee, had an application in the Patent Office, saw the Ford product and was able to amend his application to draw claims which would cover, as we say in the patent law, our construction.

Something should be done in that direction. A move toward correcting it is the recent decision of the Supreme Court.

Something also should be done to correct the situation brought about by the decision of the Supreme Court in 1936 in the case of *Wine v. Enterprise*. Prior to that time it had always been the construction of the law by most of the Courts of Appeal that, if a man had secured a paper patent, he had to give actual notice to anyone who he claimed was infringing that patent. The Supreme Court, in construing the section of the revised statute having to do with the matter of notice, said it is no longer necessary for anyone holding a paper patent to give notice to the manufacturer if he is going to make a charge of infringement. The result of that is that a man can hold a paper patent today and sit by for 6 years without the manufacturer having the slightest knowledge that he has been infringing.

We have one case where we have made over 27,000,000 parts, with no knowledge at all of a patent being in existence, but that man could and did make a claim for infringement, on purely a paper patent.

There are many things that should be considered, Mr. Chairman; perhaps not revolutionary but merely procedural changes.

Senator BORAH. Of course, I do not desire to urge you at this particular time, but sometime before we close these hearings I should like to have your own individual judgment with reference to the patent laws.

Mr. FARLEY. I would like very much, Senator, to make suggestions.

Senator BORAH. You believe in the patent laws?

Mr. FARLEY. Unquestionably, having been examiner with the Patent Office, I still agree with the idea of the patent system.

The CHAIRMAN. In this testimony which you have just been giving, Mr. Farley, do you speak as attorney for the Ford Motor Co., or in your own individual capacity?

Mr. FARLEY. I would say that I speak in my individual capacity as having had 15 years as a machinist, having represented the poor inventor, having served for 4 years in the Patent Office, and having had the extremely valuable experience of handling Ford litigation matters and being connected with them for the last 10 or 12 years.

Senator KING. Have you any objection to expressing an opinion as to the practice, the wisdom, or the propriety of interference?

Mr. FARLEY. The interference practice?

Senator KING. Yes. Don't you think that ought to be abolished, and if a person wants to interfere, let him go into court rather than hold it up?

Mr. FARLEY. I think the interference practice as it has developed through years of technicalities is a scar on the patent system. I have in mind a fact of which you are probably aware, the fact that when an interference proceeding starts and the matter of the question of priority is determined, the Patent Office, the men who decide that question, have never seen any one of the men who testified. I had a case a few years ago where we finally brought the case up to the district court and the inventor on the other side, after I cross-examined him for a week, admitted that the decisions which he had gained in the Patent Office had been obtained by fake drawings and untruthful testimony. That is something the examiner in the Patent Office couldn't know.

Senator KING. Would you suggest an opinion as to the propriety of amending the patent law so if a person wants to interfere, let him go into the district court, and secondly, date the life of the patent from the date the application was filed rather than from the time the interference was disposed of in the Patent Office, which sometimes carries the patent for from 20 to 30 years?

Mr. FARLEY. Certainly the suggestion which has been made many times that the patent be dated from the date of application is worthy of most serious consideration. As soon as they talk about dating the patent from the date of application the question of interference always comes up. At the end the patentee may inadvertently, through no fault of his own, be delayed many years in the Patent Office.

Senator KING. That results, as I stated, in continuing the life of the patent for many times as long as 30 years.

Mr. FARLEY. Unquestionably.

The CHAIRMAN. Mr. Cox, are you going to develop through the testimony of Mr. Ford or Mr. Farley the contrast between the two

policies which have been followed by the Ford Motor Co. as, for example, one time they took out a license and when they changed to the other policy, why that changed?

Mr. COX. I am going into the historical reasons for the Ford policy which I think will cover the matter that Your Honor brings up.

The CHAIRMAN. Perhaps you will make it a little more broad than the historical reasons.

Mr. COX. Yes, I hope to do that. I would like to ask you, Mr. Farley, along the same line you have been speaking, whether you would care to express an opinion as to whether the ease with which patents on improvements are obtained is a blemish on the patent law at the present time.

Mr. FARLEY. Well, I don't think that any practicing lawyer who has prosecuted cases before the Patent Office would be quite willing to agree that you obtain them with ease. You always have to battle with the examiner, and it is a question of your ingenuity perhaps as against his. It is, of course, quite true that too many patents are issued on trivial bases, but I don't see how that can be corrected, if you consider the fact that when a charge of infringement is made, we make exhaustive validity searches that may take 2 months. I know when I was in the Patent Office I was required or expected to turn out 25 to 30 actions a week. That means that I was acting on four or five cases a day, and making searches that probably were anywhere from half an hour to 2 hours in duration, so that it was impossible for the examiner and the efficient operation of the office purely as an administrative office to make the type of search that is necessary to really determine whether or not an idea is novel.

Mr. COX. Mr. Ford, do either of your companies now belong to the National Association of Automobile Manufacturers? Perhaps the correct name is the Automobile Manufacturers Association.

Mr. FORD. No, sir; they do not.

Mr. COX. Is it true that the Ford Co. has never belonged to that association?

Mr. FORD. The Ford Co. has never belonged to the association.

Mr. COX. There was an interval of time when the Lincoln Co. belonged?

Mr. FORD. The Lincoln Co. was purchased by the Ford Motor Co. as a going concern, and it had a membership in the association, and that was maintained for a few years.

The CHAIRMAN. Would you be good enough to bring out what that association is?

Mr. COX. Can you explain briefly what it is? I have a witness who is going into that, who is going to follow Mr. Ford.

The CHAIRMAN. For the benefit of the committee, you may state on your own authority, if you will be good enough, what you intend to show this association is.

Mr. COX. I think perhaps it would be enough at this time, if I say that the Association of Automobile Manufacturers is a trade association to which almost all of the manufacturing companies in the automotive industry belong, with the exception of Mr. Ford's company, and one or two smaller companies. It performs the usual functions of a trade association, I understand, collects statistics, is responsible, I believe, for the safety campaigns that are carried on from time to

time with respect to traffic problems. Our chief interest in this association at this time is the fact that the association is the medium by which a cross-licensing agreement has been carried on in the motorcar industries since 1914. I propose to go into that cross-licensing agreement, its history, the reasons for its adoption and what its effect has been in the industry, with another witness.

I am attempting now merely to develop the attitude of the Ford Co. with respect to the association and the cross-licensing agreement.

The CHAIRMAN. Thank you, Mr. Cox. You may proceed.

Mr. COX. Will you tell us, Mr. Ford, why your company has never belonged to the Association of Automobile Manufacturers?

Mr. FORD. Mr. Cox, the original association was formed around a patent known as the Selden patent, and the association was known as the Association of Licensed Automobile Manufacturers. We fought that patent.

Mr. COX. Will you tell us about what time this was?

Mr. FORD. We were sued under the Selden patent in 1903.¹ The Ford Motor Co. was organized in June 1903, and the company was sued in October 1903, and it carried through litigation until 1911.

Mr. COX. That patent was a broad patent, was it not?

Mr. FORD. It was a very broad combination patent, supposedly covering the automobile as a unit.

Mr. COX. Covered any and all kinds of gasoline automobiles?

Mr. FORD. That was the claim.

Mr. ARNOLD. It was in effect a patent on the idea of having an automobile, running it, wasn't it?

Mr. FORD. I think so.

Mr. COX. Do you remember whether the Ford Co. ever applied for a license under that patent?

Mr. FORD. I understand that it did.

Mr. COX. Your father?

Mr. FORD. My father; yes.

Mr. COX. Can you tell us what happened in that connection, Mr. Ford?

Mr. FORD. I can't recall exactly the date this took place, but it was at one time during the course of the early days of the Ford Motor Co., when we were a small manufacturer and getting started. The association had been started and had acquired numerous motor companies as members. These members paid a license fee to the association under the Selden patent. My father inquired of one of the officers of the association if it were possible to join this association and become a member as the other motor-car companies were. He was told, I understand, he had best go out and manufacture some motor cars and gain a reputation and prove that he wasn't a fly-by-night producer before he should ask for a membership in this association.

Mr. COX. They weren't sure your father was the proper kind of person to make motor cars?

Mr. FORD. So I understand. [Laughter.]

Mr. COX. Of course it would be rather difficult, assuming that that patent was valid, for your father to make a reputation manufacturing motor cars without a license.

¹ See corrected statement of Mr. Ford, *infra*, p. 271.

Mr. FORD. If the patent had been sustained, I think the Ford Motor Co. would have been put out of business or would have become a member of the association, one or the other.

Mr. COX. The association sued your father's company immediately after this refusal of a license, is that a fact?

Mr. FORD. In 1903, in October, the company was sued by the association.

Mr. COX. Perhaps Mr. Farley can tell us the steps in that litigation.

The CHAIRMAN. May I interrupt before that question is answered? Mr. Ford, did this association of which you speak charge a royalty for the use of this patent?

Mr. FORD. Yes, sir.

Mr. COX. What was that royalty, Mr. Ford?

Mr. FARLEY. It was originally \$15 a car and then later changed to a percentage of $1\frac{1}{4}$ percent of the sale price of the car.

Mr. COX. It might be interesting, Mr. Farley, if you could tell us whether the association, that association, adopted a very aggressive litigation policy.

Mr. FARLEY. I would say it had adopted a most aggressive not only litigation policy but publicity campaign in connection with the Selden patent. There are some very interesting phases of the matter. The association apparently was organized or instigated by the then Pope-Hartford Co. which had contemplated putting a machine on the market, and they had a patent attorney in their employ who had run across the Selden patent and advised his company that they couldn't manufacture without infringing, and then steps were taken to organize the Association of Licensed Manufacturers. The first part of the litigation was conducted by suit against the Winton Co. and against various dealers and users of automobiles. Consent decrees were obtained against some people and particularly the suit against the Winton Co. was settled about a day or two before the consent decree was issued and there were provisions to the extent that the Winton Co. would have a rebate of \$50,000 given to it on its future license payments. They had worked up quite a defense, but included in the settlement agreement was a payment to the attorneys of the then Winton Co. and all of the defense material was turned over to the attorneys for the association, so that when the Ford case came to trial a great deal of the defense material which had been procured earlier was no longer to be found, and the Ford Co. then was compelled to begin its actual trial work in which a great many items of defense, so I understand, were no longer available to it.

Mr. COX. Is it true, Mr. Farley, that that association threatened to sue not only the manufacturers who were asserted to be infringing the patent, but also any ultimate consumer who bought a motor car and operated it?

Mr. FARLEY. The record of the Selden case shows and contains many of the advertisements that were appearing in the papers at that time in which users were notified that they would be equally liable as infringers or as much liable as infringers as the manufacturer, which, of course, is true under the provisions of the patent law.

Mr. Cox. That suit was first heard in the district court in the usual manner, wasn't it, Mr. Farley? Just tell us what happened in the steps of the suit.

Mr. FARLEY. In the trial in the district court, of course, a great many witnesses were called, the plaintiffs had a most imposing array of counsel and had imported for the purpose of the case one of the best known and earliest writers on the internal combustion engine from England, Sir Dugald Clerk. He was the principal expert for the plaintiff, and I don't know how long the trial lasted, but finally the district court decided the case against the Ford Co. The history of the case and the facts involved seem to me are brought out better by some of the excerpts from the decisions of the court. I have made some extracts and I can either introduce those in the record and save time, or whatever you prefer.

Mr. Cox. We might deal with them that way. I am primarily interested in the steps in the litigation sense of the decisions which were made. The case then was appealed to the circuit court of appeals?

Mr. FARLEY. Yes; the case was then appealed to the circuit court of appeals and the decision was rendered September 19, 1909, and the decision in the upper court was in 1911, in January, in which the upper court reversed the decision of Judge Hough and held that the patent though valid should be restricted to the particular type of engine shown in the Selden patent and that the Ford construction did not infringe.

The CHAIRMAN. What is the citation of those cases?

Mr. FARLEY. The lower case is cited in 172 Federal Reporter, page 923, and the upper case is in Second Circuit Court of Appeals reported at 184 Federal Reporter, page 895. They limited the Selden patent and restricted it to certain phases but not to combustion engines with modifications which other corporations adopted.

Briefly, the situation there was that Selden had a combination claim in which he included in his claim the type of an engine which he defined as "a liquid hydrocarbon gas engine of the compression type." He had selected a type of internal-combustion engine known as the Brayton engine which was designed to simulate as nearly as possible the pressure cycles of the steam engine, and it was a two-cycle engine with a pump on the outside in which the gas was compressed and the gas sent into the combustion chamber and ignited by a flame. He had no carburetor, no electric ignition, and Mr. Ford, of the Ford Co.—in fact, all of the developers of practical automobiles of that day had all used what was known as the Otto 4-cycle engine with electric ignition and carburetor and all that sort of thing.

The CHAIRMAN. Mr. Cox, if it is not inconvenient for you now, and if no member of the committee desires to ask a question—

Dr. LUBIN (interposing). Mr. Farley, do you know whether the association under the Selden patents ever sued a consumer for violation of the patent?

Mr. FARLEY. You mean a user? It is my understanding that is true. A survey in the examination of the *Selden case* was made a short time ago, in 1931, in fact, not at all having anything to do with this case, and there was one case that was brought against a user.

Mr. COX. I think it is just a letter threatening suit. I think it was a matter of threat.

Mr. FARLEY. There were threats, but we have in this notation a case of a man by the name of Moore who bought a car known as the Martini. It seems that he left New York; he was quite a sportsman, or something, a wealthy man and left New York and went to Texas and never appeared, and as I understand it, a consent decree was obtained against him and injunction issued. I take that, however, from this article, something that I prefer to check with the records in the New York office.

Mr. ARNOLD. In any event, no one there had the resources to fight this hampering on the manufacturing of motor cars to a successful conclusion. That is a fact, isn't it?

Mr. FARLEY. I think that is probably quite true.

The CHAIRMAN. At least nobody else did.

Mr. PATTERSON. I have a question I would like to have cleared up in my mind, Mr. Ford. When the Ford Co. was beginning in the industry, did it then have a free licensing policy, at the beginning, the start? ¹

Mr. FORD. I would think so, but I am not positive. It was before my time, and I don't remember positively.

Mr. PATTERSON. When the Ford Co. assists patentees to develop and manufacture—we were on that topic a half hour ago—what does the Ford Co. ask in return for that assistance in manufacturing and developing patents?

Mr. FORD. Nothing, except the right to use the article which we purchase.

Mr. PATTERSON. That is my understanding. I merely wanted to clear it up.

The CHAIRMAN. This policy of free licensing was not adopted at the very beginning?

Mr. FORD. I don't recall.

The CHAIRMAN. Wasn't it your original testimony that you did have a license at the beginning?

Mr. FORD. We sued once, and we granted one license; but I don't think that would make a general policy.

Mr. COX. To clear that one instance up, isn't it a fact that the one instance where you sued another manufacturer, that was done at the time that manufacturer was a member of the association, and you were engaged in a controversy with the association over the Selden patent?

Mr. FORD. That is right. They were an aggressive member of the association and they were pursuing us and we felt that we had this basic patent that they were using and we thought we might retaliate.

The CHAIRMAN. If there are no other questions at this time, the committee will stand in recess.

Mr. FORD. May I make a correction? I made the statement awhile ago that the Association of Licensed Automobile Manufacturers sued the Ford Motor Co. My information here is that it was brought in the lower court by the Electric Vehicle Co. and George B. Selden.

(Whereupon at 12 noon a recess was taken until 2 p. m. of the same day.)

¹ See, *infra*, p. 273, et seq., for additional testimony re early patent policy of Ford Co.

AFTERNOON SESSION

The committee resumed at 2:04 p. m., on the expiration of the recess.

The CHAIRMAN. The committee will please come to order. Mr. Cox, are you ready to proceed?

Mr. Cox. Yes, sir.

TESTIMONY OF EDSSEL FORD, PRESIDENT, AND I. JOSEPH FARLEY, PATENT COUNSEL, FORD MOTOR CO., DETROIT, MICH.—Resumed

Mr. Cox. Before the committee arose, Mr. Ford, we were discussing the Selden suit and the relations between your father and the Association of Automobile Manufacturers at that time. I understood you to testify, in effect, that from the day that your father was refused a license by that association it has been the policy of the Ford Co. not to belong to that association or any successors of it, and not to be a party to any cross-licensing agreement. Is that correct?

Mr. Ford. That is our general policy. We did belong as members of a nonlicense association at one time, during the early days of the industry, an association of members of motorcar manufacturers that were not operating under the so-called Selden patents.

Mr. Cox. How long ago was that?

Mr. Ford. That was in the same period, between 1903 and 1909, I think.

Mr. Cox. Do you recall when you ceased to be a member of that?

Mr. Ford. No; I do not.

Mr. Cox. You are aware, of course, Mr. Ford, that the policy of the Association of Automobile Manufacturers has changed since 1911, so far as the granting of licenses is concerned, under the terms of their cross-licensing agreement?

Mr. Ford. I don't quite understand what you mean, Mr. Cox.

The CHAIRMAN. May I ask the interrogators and the witness to talk into the microphones? The questions and answers are not being heard.

Mr. Cox. I will put the question this way: Are you aware that it is now and has been for some time the policy of the Association of Automobile Manufacturers not to refuse membership in their cross-licensing agreement to anyone who wishes to become a member?

Mr. Ford. I understand that is the policy at the present time.

Mr. Cox. Do you also understand that that policy has been the policy for a number of years?

Mr. Ford. Yes, sir.

Mr. Cox. Despite that change in their policy from the policy that was pursued in 1911, your companies have nevertheless not seen fit to join the association?

Mr. Ford. That is right.

Mr. Cox. Not because there was any denial of your right to join but because you preferred not to?

Mr. Ford. As a matter of policy we preferred not to.

Mr. Cox. Do you have any opinion as to whether the cross-licensing agreement, which is administered by that association, has been or is a beneficial thing for the automotive industry?

Mr. FORD. I should think it had been a beneficial thing to the industry.

Senator KING. It prevents litigation.

Mr. FORD. That is right.

Senator KING. And permits the members of the organization to have the benefit of any patents which are brought within the terms of the agreement.

Mr. FORD. That is right.

Mr. COX. There are one or two additional matters that I passed over this morning that I should like to ask you about, Mr. Ford, for the record. Can you tell us how many patents your companies now own?

Mr. FORD. The record that I have shows that we own 409 patents.

Mr. COX. Could you tell us how many licenses under those patents your company has granted? For the record perhaps it should be stated whether these are patents either of the Ford Co. or of both the Ford and the Lincoln Co.

Mr. FORD. I don't think I can distinguish between that.

Mr. COX. Do they include both parties?

Mr. FORD. Yes; they include both parties. I don't know the figures for each company. The total is 409.

Mr. COX. The last total for the licenses given?

Mr. FORD. For the patents only.

Mr. COX. Now will you give us the total of the licenses granted by the two companies.

Mr. FORD. There is a total of 92.

Mr. COX. Can you tell us how many licenses under the patents of others your company has taken?

Mr. FORD. Five hundred fifteen.

Mr. COX. Before the recess you were asked by a member of the committee about the patent policy of the Ford Co. at its very inception.

The CHAIRMAN. Mr. COX, before the witness answers that question, may I ask whether the 92 licenses granted by your company have been granted solely to members of this association or to others outside of the association?

Mr. FORD. No, sir; that had nothing to do with the cross-licensing. Those licenses are granted to outside manufacturers.

The CHAIRMAN. So your licenses are not confined to the manufacturers of automobiles or any particular set of manufacturers?

Mr. FORD. No; they may or may not be. They may be on other processes besides the manufacture of automobiles.

The CHAIRMAN. And with respect to the licenses which you have received from others, 515 in number, how many of those have been received by the Ford Co. and how many by the Lincoln Co.?

Mr. FORD. They are all granted to the Ford Motor Co.

The CHAIRMAN. Thank you.

Mr. COX. I just called your attention to the fact that before the recess a member of the committee had asked you a question with respect to the patent policy of the Ford Co. in its very early days, in fact at its inception, and I think you answered you couldn't recollect the details of that policy.¹ If I suggest to you that it was the policy

¹ See supra, p. 271.

of the company in its very inception not to grant licenses under any of the patents which it owned at that time, would that refresh your recollection at all as to the situation?

Mr. FORD. I couldn't say whether that is true or not. I doubt whether it is true.

Mr. COX. I should like to ask this question with respect to your policy of granting royalty free licenses under your own patents. It makes no difference with respect to granting those licenses how much money you may have expended in experimental and development work in perfecting patents?

Mr. FORD. It makes no difference.

Mr. COX. The policy applies to all patents regardless of the expense incurred.

Mr. FORD. That is true.

Senator KING. Do many of the companies avail themselves of the patents which your company holds and which you give to them freely?

Mr. FORD. Yes; there have been 92 granted. That is not to other motorcar companies; those are to suppliers usually.

Senator KING. Then all of these patents do not relate to important parts of your automobile?

Mr. FORD. Not necessarily. They may have to do with processes involved in the manufacture of motor cars.

Mr. OLIPHANT. Do you grant licenses to other automobile manufacturers?

Mr. FORD. We would.

Mr. COX. Have you?

Mr. FORD. We have, Mr. Farley says; I don't recall the instance.

The CHAIRMAN. Of the 515 licenses which you have taken, you have granted only 92, if I remember your testimony correctly.

Mr. FORD. We have received 515 and granted 92.

The CHAIRMAN. That was my understanding.

Mr. FORD. That is right.

Mr. COX. The sum of the 92 licenses which you have granted have been to other manufacturers of motorcars, is that a fact?

Mr. FORD. I wouldn't say so. There have been some.

Mr. COX. Some have been but not all?

Mr. FORD. Yes.

Mr. ARNOLD. A lot of your patents have to do with manufacturing processes which could be used in any manufacturing industry and on which you could charge royalties far beyond the mere manufacture of an automobile?

Mr. FORD. That is true.

Representative SUMNERS. Mr. Ford, do you grant licenses to those who do not grant licenses to you? Do you have any system of mutual exchange?

Mr. FORD. We have a system of mutual exchange and we also grant licenses to those who do not grant to us.

Representative SUMNERS. Would you grant a license to one who would not grant a license to you?

Mr. FORD. Where they had a process that we wanted, and we had one that they wanted?

Representative SUMNERS. I think I would rather stand on the question just as I asked it.

(The reporter reread the question: "Would you grant a license to one who would not grant a license to you?")

Mr. FORD. Yes.

Representative SUMNERS. Why?

Mr. FORD. Because of our policy of granting licenses freely, and giving shop rights.

Mr. ARNOLD. In other words, you do not wish that kind of control—

Representative SUMNERS (interposing). Wait a minute, let me finish. I want to get that pretty clearly. If somebody came to you and wanted you to grant the use of a patent that had been issued to you either as the original patentee or as assignee, and while in conversation you would say, "Well, you have got one I would like to have, too," and he would say, "You can't have mine," what would you do about it? I mean, do you have that ever occur as a practical situation?

Mr. FORD. I don't think that has ever occurred that I know of, but I would like to face that problem when it came up.

Representative SUMNERS. I think I would, too.

Senator BORAH. Your system of granting licenses doesn't arise out of a particular advantage which you may derive from that grant, does it, or as a general policy?

Mr. FORD. As a general policy.

Senator BORAH. And, therefore, you certainly wouldn't change a general policy because some particular individual isn't willing to live up to your policy.

Mr. FORD. That is true.

The CHAIRMAN. I assume there are some patents in the automotive industry which have been issued to others and under which you have not been licensed, but which you perhaps would like to use if you could be licensed under them.

Mr. FORD. A reciprocal arrangement?

The CHAIRMAN. No; I am just wondering if it is not the fact that there are some patents on devices in the automotive industry which you are not permitted to use by the holders of the patents.

Mr. FORD. And that we would like to?

The CHAIRMAN. And that you would like to.

Mr. FORD. Yes; I think so.

Senator KING. Out of the 92 which you have granted to others, do you recall whether any of the grantees have refused patents or the right to a license to your organization?

Mr. FORD. I don't know that detail, but it could be very easily ascertained.

Senator KING. And when you have granted these licenses to others, have you told them that you were doing it only upon the theory that if they have patents which you would like to use that they will assign to you?

Mr. FORD. I should think that in very few instances they have things that we want to use; there are those cases that arise, of course, and particularly in manufacturing processes there are many times where we are developing an art and the outside party is developing an art at the same time. We make a cross agreement so that anything new that we are able to contribute they get the benefit of, and anything they are able to contribute we get the benefit of.

Senator KING. Those are special arrangements that may be entered into?

Mr. FORD. Yes.

Mr. COX. How many of those do you have, Mr. Ford?

Mr. FORD. Five hundred fifteen license agreements, and those cover many more patents than that. One agreement might cover many patents, you see. Mr. Farley says over 3,000 patents are involved in those license agreements.

Mr. COX. What I was really interested in was how many of those involved this reciprocal arrangement.

Mr. FARLEY. I might answer that, if you don't mind, Mr. Cox. A great many of them are involved, so it would be very difficult to get exact information without reviewing all of the license contracts we have in our files.

Senator KING. I suppose most of those licenses to which you are now referring are not primary, in the sense that they are not an important factor in the manufacture of an automobile.

Mr. FORD. They may be important, but they are not, possibly, major items in the direct manufacture of a motor car. They may have to do with processes—paint, for instance. I know we manufacture paint, and we have a cross-license arrangement with the duPont people whereby we do just as I cited a few moments ago. We exchange our ideas.

Mr. ARNOLD. Types of conveyors, and things like that, would be included.

Mr. FORD. I would think so. I don't recall whether that is an actual fact.

Senator KING. Loading and unloading devices from trains and cars?

Mr. FORD. It might cover most anything. I don't recall those particular instances.

The CHAIRMAN. In other words, the patents to which you refer are not exclusively those of devices which go into a car but include devices which are used in the factory for the manufacture of the car and which could be used for the manufacture of many other different kinds of machines.

Mr. FORD. That is right. It covers a very wide range of devices. I have a list, if you would be interested in some high spots of it.

The CHAIRMAN. It might be satisfactory to put that into the record without reading, Mr. Cox.

Mr. COX. I will be glad to do that if you will take it out of the book. It can be marked as an exhibit.

(The list referred to was marked "Exhibit No. 90" and is included in the appendix on p. 669.)

Senator KING. As illustrative of the importance of some of these patents and controversies, Mr. Farley mentioned cafeterias. Do you have some controversy over patents for cafeterias, and get cross-licenses there?

Mr. FARLEY. That came under the question relating to the threats received by the company. Somebody had a patent on these tubular bars that you see running around the counters, and they were installed in the cafeteria of the employees of the Ford Co., and we were threatened with suit under that patent. I don't think anything was ever done about obtaining a license, so far as I know.

Mr. Cox. If we can have that list we will include it in Mr. Ford's testimony.

Would you say, Mr. Ford, that the patent litigation has been a financial burden to your company?

Mr. FORD. It has been a very definite expense as we have gone on from year to year.

Mr. Cox. Do you have any figures on that that you can give us?

Mr. FORD. I can say that our general patent expense runs between 90 and 100 thousand dollars a year.

Senator BORAH. How much of that goes for attorneys?

The CHAIRMAN. We will excuse the witness from answering.

Mr. FORD. I didn't hear the question.

The CHAIRMAN. That was not a question. It was merely—

Senator KING (interposing). Conversation.

Mr. Cox. Since we have been discussing this I have asked questions about the expense of litigation. Mr. Farley, as a result of your years of experience as a patent attorney, do you have any opinion as to what, if any, steps might be taken or changes made to reduce the expense of litigation so far as litigants are concerned?

Mr. FARLEY. I hardly see how it is possible to reduce the expense of litigation to litigants, either plaintiff or defendant. We are confronted in our cases in not knowing whether or not we are going to be before a judge who may or may not be experienced in mechanical matters. We proceed on the theory—and I am speaking now merely as a patent lawyer—that whether for plaintiff or defendant, we must make the case as simple as it can possibly be made. That involves relatively high expenditures for the preparation of the descriptive charts and models and all that sort of thing, and I don't see how that sort of expense can be avoided so long as we operate under the present system. I think it is a subject that is worthy of careful study and consideration as to how those conditions might be improved.

Mr. Cox. Would you say that the holder of a patent who did not have large resources was at a serious disadvantage in carrying on patent litigation at the present time?

Mr. FARLEY. If you speak of the holder of a patent, the job is very much easier for the holder of a patent, that is, for the plaintiff. In practically all of the cases in which I have been engaged with the Ford Co. the expenditures by the plaintiff are relatively nil. A man who has a patent and can convince counsel that he has even the barest possibility of success can always get counsel to take cases on a contingent basis. I venture to say that well over 90 percent of the cases brought against the Ford Co. are cases in which the suit for the plaintiff has been taken on a contingent basis.

Representative SUMNERS. Mr. Cox, may I ask Mr. Farley a question at this point?

Mr. Cox. Yes, sir.

Representative SUMNERS. Mr. Farley, would it embarrass you in the preparation of your reply to the suggestions of the committee to express some opinion as to whether or not, as a condition attached to the patent, there ought to be the obligation, under proper safeguards and compensation, to grant permits to use, licenses, to any applicant?

Mr. FARLEY. That is a subject that has come up quite frequently, Mr. Congressman. The proposal has frequently been made. I as-

sume you are referring to what is known as compulsory license provisions.

Representative SUMNERS. Here is what I am referring to, and I think it is one of the most important things, if not the most important thing, with which this committee has to deal. That is, whether or not, when the Federal Government grants a patent, which is an exclusive right to use an idea, there ought to be some agreement under which the patentee could not refuse the granting of the right to use to anybody who paid a reasonable compensation for the right to use.

Mr. FARLEY. Well, there are some adherents to that proposal, but every time it is raised a storm of protest comes up from what is known as the poor inventors. It is always thought that the large corporations would gain most from that sort of provision of the law, and it may have some advantageous features. I know that that sort of provision has been in effect in Canada and England, but it is very rarely used. It is honored more in the breach than in the observance in those countries where that provision is in effect.

Representative SUMNERS. Is it honored more in the breach than in the observance, or is it the effect of there being that power of compulsion that makes people get together and agree? So far as I am concerned as a member of this committee, that is one of the things that I am mainly concerned about. There is no use in having you witnesses come here just to give us all these details.

Mr. FARLEY. I think that is a subject worthy of careful consideration.

Representative SUMNERS. Will you consider it carefully?

Mr. OLIPHANT. You say the objections come mostly from poor inventors. Is there any association of these poor inventors from which those objections come, or does the objection come from the patent bar?

Mr. FARLEY. There is an association of inventors that gives an annual show in New York, and I know that every time the proposal has been made, objections have been registered by that committee or that association. I think a great many, of course, are registered by the patent bar.

The CHAIRMAN. May I say to the members of the committee that it is my understanding that this particular subject matter on which these questions are now being asked is being given special study under the Commissioner of Patents and Dr. Thorp and Secretary Patterson, so that it will come up at a later hearing. Perhaps we should not interrupt Mr. Cox's examination with that matter at this time.

Senator KING. Notwithstanding the statement made by the chairman, may I say for the enlightenment of my friend from Texas that at the last session of Congress a bill known as the McFarlane bill was introduced which had for its purpose compulsory licensing, and my understanding is—and I examined hastily the testimony—that only one person testified in favor of it, but a large number of persons testified in opposition, and they came largely from the ranks of the small inventor and the manufacturer who would be denominated in the lower class so far as finances are concerned.

Mr. FARLEY. That is quite true. I am familiar with the legislation and the hearings.

Senator KING. I offered a bill for compulsory licensing, but I didn't get any support, and I am not sure I am for it myself.

Mr. FARLEY. I think one of the objections raised by the patent bar is that practically every proposal that has been made along that line attempts to throw the job on the Commissioner of Patents, and we are inclined to think that the Commissioner and his office are too much overburdened to have that additional job thrown on them.

Mr. Cox. Mr. Ford, if it should be suggested to you that the reason your company grants free licenses under your patents is because the patents are of no particular importance so far as the manufacture of cars is concerned; in other words, of little value in the art of manufacturing cars, would you accept that as an accurate statement?

Mr. FORD. I wouldn't say so. I think some of them are of definite importance.

Mr. Cox. You would say they are important and valuable; and would you say they are patents out of which you might, if you cared to, make appreciable sums of money in the form of royalties under license agreements?

Mr. FORD. I think we could, if we were so inclined.

Mr. Cox. But you are not interested in making money in that way?

Mr. FORD. That is right.

Mr. Cox. You will recall this morning, in response to questions by members of the committee, Mr. Farley expressed the opinion that he was in favor of the patent system—I think that is accurate—not of all its details or the way it operates, but he thought basically it was probably a wise, beneficial thing.¹ Do you have any opinion on that question that you would care to express now?

Mr. FORD. I have no opinion other than Mr. Farley's. I think he expressed exactly the way I feel about it.

Mr. Cox. I think that concludes my examination of Mr. Ford.

Senator KING. That is, I understand, Mr. Farley, that you believe it is a wise provision in the Constitution authorizing Congress to grant patents for inventions and discoveries.

Mr. FARLEY. Unquestionably.

Senator KING. And the patent law pursuant to that constitutional warrant has served, by and large, a useful purpose?

Mr. FARLEY. Unquestionably; and, of course, we feel at times that, viewing the matter from the standpoint of being made the defendant in all sorts of harassing litigations, our general feeling is that the system has got to the point where the tail is wagging the dog, and that it isn't acting 100 percent to promote progress, but in many instances is used to impede progress.

Senator KING. That could be avoided in part, could it not, if there were more care in the issuing of patents, and not granting patents without further examination than is now made? That could only be done, perhaps, by augmenting the force in the Patent Office. Too many patents are issued, too many without sufficient—

Mr. FARLEY (interposing). Careful examination. I think that is undoubtedly true.

The CHAIRMAN. Mr. Arnold, do you care to ask either of these witnesses any additional questions?

Mr. ARNOLD. No.

The CHAIRMAN. Congressman Sumners?

¹ See, *supra*, p. 262 et seq.

Representative SUMNERS. I yield to Mr. Oliphant but I do want to ask a question.

Mr. OLIPHANT. You said this morning the great mass of important inventions were the result of organized engineering work, as opposed to the individual genius working in the garret.¹

Mr. FARLEY. No; I think you probably misunderstood me somewhat. I don't mean to say necessarily "organized engineering work," but work of the engineers who are in the various industries who are thinking more of doing an effective job at the time. It doesn't necessarily have to be organized; it may be the chief engineer and the only engineer of a small company who is doing something to improve the product of his company.

Mr. OLIPHANT. I accept your description of the situation, which is quite accurate. Does that substantially describe the situation at the time the constitutional provision was adopted, or the time our patent laws took form?

Mr. FARLEY. I don't think it can, because obviously the condition of industry and engineering development at the present day is quite radically different from what it was at the time we were a rural country.

Mr. OLIPHANT. Inventions can be nearly made to order, in terms of our engineering ability.

Mr. FARLEY. We feel so.

Senator KING. However, there were patents issued by the various States before the Constitution was formed.

Mr. FARLEY. That is true as a historical fact.

Senator KING. And the constitutional provision was bottomed in part upon the form of the patents which were provided for in the various Commonwealths of the confederation.

Mr. FARLEY. Yes; and I think decidedly more important, however, on the historical development of patents in the mother country, England.

Mr. OLIPHANT. In the development of our technology do you think the bottle neck is the inventive genius as opposed to necessary capital, or what have you?

Mr. FARLEY. If I understand your question of the bottle neck, I wouldn't say that inventive genius is a bottle neck, but there may be a bottle neck on the part of men who are rather more patent minded than they are seeking to make a real contribution which they can develop and give to the general public. I have said that the patent system seems to me to have sort of degenerated into the fact that a great many people to whom patents are granted, and a great many who seek to obtain patents, do it in possibly the same spirit of mind that one purchases a ticket for the Irish sweepstakes, some sort of gamble that they may or may not cash in on.

Mr. OLIPHANT. Is the situation today that there are numerous usable patents looking for capital or much capital looking for usable patents?

Mr. FARLEY. I wouldn't attempt any answer in percentages. I think you are going to find that there are both classes. I know of many instances of both.

Representatives SUMNERS. I would like to ask some questions, if you please, sir, and if there are any of these questions that would be em-

¹ See, *supra*, p. 262 et seq.

barrassing to you at all, you just indicate it and I will depend on somebody else for the information. We are investigating here about patents, and there are just two or three things that we can inquire about. One is, ought there to be patents? Second, if there are to be patents, should the patentee have the right of exclusive control of the use of the thing patented until the expiration of the patent? That is the situation now, isn't it?

Mr. FARLEY. That is the present law.

Representative SUMNERS. The third proposition is, if a patent is granted, ought there to be some arrangement, some condition attached to that patent, under which that situation can be changed and other people would be privileged to use that idea? That would carry with it some notion of compulsory granting of license, because they have got now the right, by mutual consent, to make any kind of contract or agreement they want. What I am trying to find out is this: We have got all this crowd of people here, and we are here, and what is it we are trying to find out this afternoon? Just three things, isn't it? Is there anything between those three points I have indicated that we could be inquiring about as a practical proposition?

Mr. FARLEY. Of course there are very many ramifications of the system that I don't think you need to get into. Do you care to have me answer those three questions?

Representative SUMNERS. I do.

Mr. FARLEY. Will you repeat them?

Representative SUMNERS. What I am trying to find out is, ought we to do anything about this business; second, if so, what?

Mr. FARLEY. My answer to that would be yes.

Representative SUMNERS. Can you tell us now, or do you want to do it later?

Mr. FARLEY. What should be done?

Representative SUMNERS. Yes.

Mr. FARLEY. That is a matter, as I say, that I did not come here prepared to make specific suggestions on. It is something that should be done only after careful study. I would be glad to make them.

Representative SUMNERS. I think those are all the questions there are.

Mr. ARNOLD. Mr. Farley, would you agree to this analysis of your present position? There are two questions in the patent field, in getting a solution of the patent problem. First, a reward to encourage the inventor.

Mr. FARLEY. Correct.

Mr. ARNOLD. And, second, to avoid doing so in such a way that you create a combination which restrains the industrial arts and thereby restrains trade. There may be other questions, but those are at least two, and the policy of the Ford Co. represents a policy which at least prevents this combination in restraint of the industrial arts.

Mr. FARLEY. That is true.

Mr. ARNOLD. And the enormous growth of the automobiles from 1925 on is some evidence of the success of that policy in the industrial arts.

Mr. FARLEY. I would think that is quite true too, I agree with that.

Mr. ARNOLD. Now, the remedies fall into several classes: First, the remedies which the Antitrust Division are most interested in, that is the prevention of combinations, and second, the remedies which more clearly fall within, we will say, the Department of Commerce, the improvement of the patent laws, the stopping of this litigation. Those merge together, but there are those two separate aspects.

Mr. FARLEY. Correct.

Mr. ARNOLD. This hearing, as I see it—and I wonder if you will agree with me—is one directed chiefly at the combination end of the patent problem.

Mr. FARLEY. Well, I accept your statement as to what your committee is intending to investigate.

Mr. ARNOLD. Not the committee, but clarifying it for the purpose of the Department of Justice and its function in this particular hearing.

The CHAIRMAN. Senator Borah, do you have some questions?

Senator BORAH. Mr. Ford, you have been paying out something like a hundred thousand dollars a year for patent laws in the past 2 years. Have you anything to suggest to this committee in the way of constructive legislation with reference to patent laws?

Mr. FORD. Two points that Mr. Farley mentioned this morning, I believe: One, I feel some restriction in the length of time that a patent is allowed to remain in the Patent Office before it is issued. I think that is a definite detriment. I also think that, as recited in this case where no notice has to be given necessarily now of infringement—that is one that may lead industry into very deep channels without their knowledge of it when a patent is being violated without the knowledge of the violator, and that policy of notice has been in effect up until the Supreme Court decision which took place a few months ago, in 1936. I think that is a very definite detriment. As far as the length of life of a patent and other things, I don't think I am qualified to express myself on that.

Senator KING. In the light of the suggestions made by Judge Summers asking Mr. Farley to give his views, I would like to make a few suggestions, if I may, and ask you in preparing to give your views respecting procedure and what might be done to mitigate some of the evils now resulting, to consider these suggestions I propound to you.

Mr. FARLEY. I will be very glad to.

Senator KING. First, decrease in number of patents. Do you not think that we should have fewer and better patents?

Mr. FARLEY. The answer to that is unquestionably yes.

Senator KING. And should it not be made more difficult to secure a patent, and should there not be assessed yearly fees on patents which would lead to cancelation of worthless and obstructive patents? I don't ask for an answer now.

Mr. FARLEY. I am personally in favor of that. I am not expressing that as a policy of the company.

Senator KING. A question as to validity of patents. Do you not think that patent applications should be examined more thoroughly and to that extent there should be given to the Patent Office a larger force of persons as examiners, particularly some who are familiar with the question of patents and their intricacies and so on?

Mr. FARLEY. I would like to say hurrah to that.

Senator KING. Do you not think that effective publicity should be given to every application before the issuance of a patent so as to encourage any possible objections or make it possible for any person to submit objections to the granting of the patent?

Mr. FARLEY. I could answer that now; if that means opposition proceedings with the right of the manufacturer to oppose a patent either shortly before or shortly after the grant, it has some advantages, some great advantages, if we are not going to have tacked to it a provision such as exists in the German law that if opposition is not made within the 5-year period the patent is unassailable. If any provision of that type were attached to the law, I would be very much opposed to it.

Senator KING. Do you think it would be wise to annex as a provision to the granting of the patent a provision that if the validity is to be tested it must be done within 5 years?

Mr. FARLEY. No; I think it would be most detrimental to have a provision of that type.

Senator KING. I wish you would examine the question as to the assumption of validity of patents and preliminary injunction. As you know, now that question is greatly befogged, and it is insisted by some that before a preliminary injunction even should be granted the validity of the patent shall first be determined by the courts. I wish you would give us your views with respect to that. Do you think there ought to be cumulative damages and costs in order to discourage intentional infringement of patents and malicious infringement suits? Do you think we ought to recommend adoption of a system of cumulative damages and cumulative costs in cases of the character just indicated, where they are malicious suits for infringements or unjustifiable suits?

Mr. FARLEY. I am rather inclined to favor that.

Senator KING. Have you any views to suggest—I won't ask you to express them now—on the question of Court of Patent Appeals?

Mr. FARLEY. Yes; I have some views on that subject.

Senator KING. If you will elaborate those I will be glad. I wish you would also consider the question of bringing suit for infringement in various jurisdictions. Ought there not to be a limitation so that if A claims that B has infringed his patent he may not sue in one jurisdiction and get an adverse decision and go into another court in another part of the United States and bring there a suit for infringement?

Mr. FARLEY. That certainly should be an end to that practice.

Senator KING. So there ought to be some amendment to the law in respect to that matter.

I have a number of others, but I will be very happy to talk to you before preparing your brief, and I would like to make some suggestions so you can inform the committee—at least inform me—as to what changes you think should be made in the procedure, because I think procedural matters are very important.

Mr. FARLEY. May I have a written statement of those questions?

Senator KING. Yes.

The CHAIRMAN. Mr. Patterson, do you care to ask any questions?

Mr. PATTERSON. Not at this time.

Representative REECE. I should infer from your statements this morning, Mr. Ford, that it is the attitude of the Ford Motor Co. that there should be a wide and unrestricted competition among automobile manufacturers.¹ If your father had joined the Automobile Manufacturers Association, and no other manufacturer had come along sufficiently strong to have disregarded that association, would that not have tended to restrict competition in the industry?

Mr. FORD. I feel very definitely that would have.

Representative REECE. Now, I don't want any possible political significance to be imputed to this phase of my question. If the Ford Motor Co. had seen fit to have signed up under the N. R. A. Code, might not that possibly have had the same restrictive influence on competition?

Mr. FORD. I feel definitely so.

Representative REECE. It would be interesting to know if as a result of the Ford Motor Co. not having agreed to the N. R. A. Automobile Code, the opportunity to sell or to bid for the sale of automobiles or motorcar vehicles by the Ford Motor Co. or any of its agents was restricted either by large private prospective purchasers or by governmental agencies.

Mr. FORD. I am sorry, but I have missed that last point.

The CHAIRMAN. I think, Mr. Ford, we will excuse you.

Mr. COX. May I ask Mr. Farley one more question that I would like to clean up? We were talking about the relative advantages litigation has between litigants with resources, and large resources, and litigants of small resources. You said it was usually cheaper for the plaintiff to litigate than it was for the defendant.²

Mr. FARLEY. That is right.

Mr. COX. Would you say that if the plaintiff were a litigant with large resources and the defendant a litigant with small resources, the defendant was at a substantial disadvantage?

Mr. FARLEY. Yes; that is true in certain litigation I have recently been conducting where I have been defending a very small company and where the very large company has started a train of suits, one suit after the other, three suits, and they have declared on certain of the claims of the patent before going in; we have had to prepare complete defenses on certain of these claims, and then at the opening of the trial they have relinquished their claims of infringement as to certain claims, and my client in this one particular case spent over \$5,000 in preparing only for that one phase of the investigation which was dropped at the trial and for which there can be no recovery under the present law on the part of my client for any of those expenses.

The CHAIRMAN. Mr. Ford, obviously from your testimony it is your belief and the belief of the Ford Motor Co. that this system of free and open patents has been beneficial to your company. What is your opinion as to its effect upon the motor industry as a whole?

Mr. FORD. I feel it has benefited the motor industry a great deal.

The CHAIRMAN. Would you care to tell the committee whether or not on the basis of your experience in the motor industry you would recommend a similar policy to other industries?

¹ See, *supra*, p. 259.

² See, *supra*, p. 277.

Mr. FORD. Every other industry has its own problems. I know nothing about those particularly, but as it has affected the motor industry I think it has been a beneficial policy and might be well worth looking over as far as other industries are concerned.

The CHAIRMAN. Thank you, Mr. Ford. The committee is very much indebted to you, and to you also, Mr. Farley, for your testimony today, and you now stand excused.

(The witness was excused.)

Mr. COX. Will Mr. Alfred Reeves step forward, please?

The CHAIRMAN. Mr. Reeves, will you be sworn, please?

Do you solemnly swear that the testimony you are about to give in this proceeding will be the truth, the whole truth, and nothing but the truth so help you God?

Mr. REEVES. I do.

TESTIMONY OF ALFRED REEVES, VICE PRESIDENT AND GENERAL MANAGER, AUTOMOBILE MANUFACTURERS ASSOCIATION, NEW YORK, N. Y.

Mr. COX. Mr. Reeves, will you give the reporter your name and address?

Mr. REEVES. Alfred Reeves, vice president and general manager of the Automobile Manufacturers Association, New York.

Mr. COX. Will you tell us briefly just what the Automobile Manufacturers Association is, Mr. Reeves?

Mr. REEVES. It is a trade association of some 34 manufacturers, the purpose of which is to do those things that can be done better by single units probably than by a good many units working along the same line. Would you like some of the departments?

Mr. COX. You might indicate briefly the kind of work you do.

Mr. REEVES. Well, the work has to do with highways; it has to do with safety, activities on traffic, sports, running the New York automobile show, the patent division, and activities of that kind, public relations, and all those things that a trade association naturally does.

Senator KING. Are all its members manufacturers of automobiles, or some members merely distributors?

Mr. REEVES. Only manufacturers of automobiles, cars, and trucks.

Mr. COX. I hand you this document, Mr. Reeves, and I ask you whether that is a correct copy of the constitution and bylaws of the association of today.

Mr. REEVES. It is.

Mr. COX. I should like to have this marked as an exhibit, with the committee's permission.

The CHAIRMAN. It may be so marked and entered in the record.

(The constitution and bylaws referred to were marked "Exhibit No. 91" and are included in the appendix on p. 672.)

Mr. COX. How long has the association been in existence?

Mr. REEVES. Since 1913.

Mr. COX. How long have you been connected with the association?

Mr. REEVES. Since 1914.

Mr. COX. There was a point in its existence where it changed its name, was there not?

Mr. REEVES. Yes, sir.

Mr. COX. What was it known as before it acquired its present name?

Mr. REEVES. It was originally known as the Automobile Chamber of Commerce. A short time afterwards they put the word "National" to it, and during the N. R. A. code its name was changed to Automobile Manufacturers Association, so as not to confuse it with jobbers and dealers and other types of allied trades that were having codes under the N. R. A.

Mr. COX. I hand you another document and I ask you whether this is an accurate list of the present members of the association and of the officers and directors at the present time.

Mr. REEVES. It is.

Mr. COX. With the Chairman's permission, I should like to have this marked as an exhibit.

The CHAIRMAN. It may be marked.

(The membership list referred to was marked "Exhibit No. 92" and is included in the appendix on p. 682.)

Mr. COX. What are the qualifications for membership in the association, Mr. Reeves?

Mr. REEVES. It is open to any manufacturer of cars or trucks, although it has been the custom to require that they be manufacturing for at least a year. It doesn't make any difference as to size, because some were admitted that only make 150 cars.

Mr. COX. Since your connection with the association, has it ever refused membership to anyone who applied?

Mr. REEVES. Nobody that applied, except on one occasion when we had a presentation made by some people who wanted to make application but were told that they probably had better not because they only made two cars, and at that time it was reported it was primarily interested in selling stock.

Mr. COX. How long ago was that?

Mr. REEVES. Probably 18 or 20 years ago.

Mr. COX. That was after 1914, this instance you speak of, and the person who was refused was not Mr. Ford.

Mr. REEVES. It was not Mr. Ford.

Mr. COX. The instance we described this morning took place before your connection with the Automobile Association. It is true, isn't it, Mr. Reeves, that among the other duties of the association is the duty of administering a cross-licensing agreement among its members?

Mr. REEVES. Right.

Mr. COX. Is everyone who is a member of the association a party to that cross-licensing agreement?

Mr. REEVES. Right.

Mr. COX. Is everyone who is a member of the association a party to that cross-licensing agreement?

Mr. REEVES. No. There are a couple that are not.

Mr. COX. That agreement takes the form, does it not, of an agreement between the association as such and each of the individual members that wishes to become a party to the cross-licensing arrangement?

Mr. REEVES. Yes.

Senator KING. Were those who were not a party to the cross-licensing excluded from the organization, or did they voluntarily withhold?

Mr. REEVES. They are still members of the association, and decided that the cross-licensing patents agreement didn't furnish them sufficient inducement to go into it.

THE CROSS-LICENSING SYSTEM

Mr. Cox. When was the first cross-licensing agreement made, Mr. Reeves?

Mr. REEVES. January 1, 1915.

Mr. COX. I hand you this document and I ask you if that is a true and correct copy of the first cross-licensing agreement, the one that was made January 1, 1915.

Mr. REEVES. Yes, sir.

Mr. COX. I should like to have this marked in evidence.

The CHAIRMAN. It may be marked.

(The first cross-licensing agreement referred to was marked "Exhibit No. 93," and is on file with the committee.)

Mr. COX. Perhaps at this point it might be well if we introduced in evidence a list of the charter members of the association, that is, those manufacturers who were members as of March 1, 1913, and at that time, of course, the association was known as the Automobile Chamber of Commerce, and I ask you if that is a correct list?

Mr. REEVES. It is.

Mr. COX. Very well. I should like to ask that this be marked.

(The list of charter members referred to was marked "Exhibit No. 94," and is on file with the committee.)

The CHAIRMAN. Is it your desire to have these printed at length in the record?

Mr. COX. It is not my desire. I should be satisfied to have them certified as original exhibits for the use of the committee.

The CHAIRMAN. I think that would be a very satisfactory method.

Mr. COX. Mr. Reeves, can you tell us briefly what the circumstances were which led to the making of the original cross-licensing agreement for 1915?

Mr. REEVES. Well, I think it came partially from the situation in the Selden case, the manufacturers were having great difficulty getting out production; they didn't want to be bothered with patents; they didn't want to sue one another. They had had enough concern over the Selden case itself, and there seemed to be a need for keeping patents out of the situation and trying to develop as good cars as they could produce at prices at which the public could buy because at that time most of the cars were very high priced cars.

Mr. COX. You would say, then, that it was the desire to avoid litigation and the confusion and uncertainty which results from disputes as to scope and validity of patents that led to the formulation of the agreement in the first instance?

Mr. REEVES. Yes.

Mr. COX. Now, Mr. Reeves, can you tell us briefly what the effect of that first cross-licensing agreement was, what rights did the members acquire under it?

Mr. REEVES. Well, the agreement was put through on the basis that 61 companies with at least 300 patents were obliged to sign before it became operative, so if one manufacturer had 10 patents he received licenses under 300 before he had to give licenses under his 10, and as a result of that, it became operative, and 61 companies and 547 patents were included when it started off

Mr. COX. Am I to understand, then, that the effect of the agreement was to give each manufacturer, who was a party thereto a license under patents of all of the other manufacturers who were parties to the agreement?

Mr. REEVES. That is right.

Mr. COX. Did that apply only to the patents then held?

Mr. REEVES. No; in the first instance it applied to all patents that they owned at that time and to all patents that they acquired during the next 10 years.

Mr. COX. The term of the agreement was to be for 10 years.

Mr. REEVES. A 10-year term.

Mr. COX. Were any patents excluded from the operation of that agreement?

Mr. REEVES. Yes; there was some fear that somebody might get an extraordinary patent of a revolutionary character which he thought he ought to have to himself and so there was a provision made for what was known as a class B patent which was a patent of exceptional character, totally unknown at the time of the signing of the agreement, but there were no class B patents developed during the 10-year period.

Mr. COX. Were those so-called class B patents not to be included within the scope of the cross-licensing agreement?

Mr. REEVES. That is right.

The CHAIRMAN. May I ask if any existing patents were excluded from the agreement?

Mr. REEVES. No, sir; all the patents owned by the members at the time of signing came into the pool and all that were taken out for 10 years following.

Mr. COX. You say no class B patents ever came into existence in the 10 years?

Mr. REEVES. That is right.

Mr. COX. Was an attempt ever made to have a patent classified as class B?

Mr. REEVES. Once.

Mr. COX. Will you tell us about that?

Mr. REEVES. The Hudson Motor Car Co. made an application for a class B patent on their counterbalanced crankshaft. It was ruled as not being in class B and it went to arbitration. The arbitrators voted unanimously that it was not a class B patent.

Mr. COX. That was the arbitration in which the arbitrators were two professors from Columbia University and a judge from the circuit court of appeals.

Mr. REEVES. Yes; Professor Lucke, of Columbia; Professor Pupin, of Columbia; and Judge Noyes.

The CHAIRMAN. Who handed down the rule in the first instance that it was not a class B patent?

Mr. REEVES. A special patents committee of the association.

Mr. COX. Did that agreement include patents held by subsidiaries of the manufacturing companies that were parties to it?

Mr. REEVES. If they were car manufacturers, yes; not if they were parts manufacturers.

Mr. COX. By parts manufacturers you mean someone who manufactures merely a particular part of a car, not the entire vehicle?

Mr. REEVES. Yes.

Mr. COX. Did it make any difference for the purpose of that provision if the parts manufacturer might be owned by one of the manufacturers who was a party to cross-license agreements?

Mr. REEVES. No; it was included.

Mr. COX. Even though the parts manufacturing company might be a wholly owned subsidiary?

Mr. REEVES. During the first 10-year period subsidiaries were included.

Mr. COX. They were included?

Mr. REEVES. Yes. Mr. Arvedson suggests that I make known the fact that the design patents, in the belief that they identified the product, were excepted, and also the patents that were strictly applicable to trucks or tractors or fire engines or apparatus of that kind where the art was new.

Representative SUMNERS. May I have the witness answer about trucks?

Mr. REEVES. The patents that were excepted from the agreement were patents that were strictly applicable to trucks, fire engines, tractors, or vehicles of that type that were very new in the art and not very well known and where it involved hoisting devices, loading devices, certain kinds of equipment of fire engines that it was not thought fair to bring into the agreement.

Representative SUMNERS. May I ask a clarifying question? Were patents that were used in the manufacture of trucks which had been manufactured for a long time excluded also?

Mr. REEVES. No, sir; unless it was something that could not be used on passenger cars.

Representative SUMNERS. Why wouldn't the same rule apply to the manufacturing of passenger cars that you made to be applicable to the manufacture or manufacturing of trucks?

Mr. REEVES. Well, the plan was to include all those patents that could be used either on cars or trucks, but not devices that were exclusively for the use of trucks.

Representative SUMNERS. I heard that statement but I was asking the reason. Suppose they had been making trucks of a given sort for 10 years. Why should there be an exclusion of the right to cross-use that sort of patent any more than you would have the right to use such a patent that had been used in the manufacture of passenger cars for 10 years?

Mr. REEVES. Judge, because the art in that field was new, there were some of these manufacturers, for example, making flushers only as a specialty; another was making sprinklers; and another was making fire engines only. They all had a specialty of some kind, and the theory was that in those specialties an exchange would put somebody else, maybe, in their business.

Representative SUMNERS. I can understand the reason for that, but I thought you included in your designation classification of trucks all these trucks that we see on the streets hauling heavy loads of stuff.

Mr. REEVES. Oh, yes.

Representative SUMNERS. They are not any newer than automobiles, are they? They have been using them about as long as automobiles.

Mr. REEVES. That is right. They were included.

Representative SUMNERS. In these cross patents?

Mr. REEVES. All the patents on trucks.

Representative SUMNERS. Then I misunderstood you.

The CHAIRMAN. AS I understand it, the only patents which were excluded from the agreement were patents for such devices which could be used only on trucks which were not interchangeable.

Mr. REEVES. Quite so.

Representative SUMNERS. But every interchangeable device was included within the agreement.

Mr. REEVES. That is right.

Representative SUMNERS. Let's see if that is the answer. It doesn't apply to trucks that are well established in their manufacture, does it?

Mr. REEVES. Yes. Any trucks that were being manufactured at that time, and they had patents on them, came into the arrangement.

Representative SUMNERS. Well, I don't understand it yet, but I will read the record on it.

Mr. REEVES. I am sorry. I will be very glad to answer any more questions. To put it simply, Judge, what they did was this: They simply said all manufacturers will go into this agreement, but the patents to be included in the agreement will not include patents that are only for use on trucks.

Representative SUMNERS. That is the point I am trying to get at. I have been seeing trucks almost as long as I have been seeing automobiles. What I am trying to find out is why you are excluding a patent that is used in the manufacture of some of these trucks that has been worn out and its successor has been worn out.

Mr. REEVES. We excluded them because at that time trucks were very new, companies were very small and most of the companies that were making trucks—

Representative SUMNERS (interposing). They are not new and not small now. Why don't you do it now?

Mr. REEVES. They are in now. I apologize.

Representative SUMNERS. The acoustics are not good here and I misunderstood the witness.

Mr. COX. This agreement he is talking about now is the agreement that was entered into in 1914 and it has been changed in a number of respects.

Senator KING. At the end of the 10 years was it extended?

Mr. REEVES. Yes, sir.

Senator KING. And is still in existence?

Mr. REEVES. Yes, sir; under somewhat different terms.

Mr. COX. Taking up that extension, the first extension that occurred in 1925, what important modification was made in the contract at that time, Mr. Reeves?

Mr. REEVES. The agreement was extended for 5 years to include only the patents that were in the original agreement. That is, the patents that were held or taken out by members during that 10-year period.

Mr. COX. Isn't it a fact, Mr. Reeves, that the extension in 1925 applied only to patents held as of January 1, 1925?

Mr. REEVES. Yes, sir.

Mr. COX. So that from that point on, no patents thereafter acquired for that 5-year period were to be included?

Mr. REEVES. That is right.

Mr. Cox. Did you continue the use of that classification of A and B patents in this extension?

Mr. REEVES. There was no need for B patents then because it did not include patents that were coming out.

Mr. Cox. I wish you would tell us as briefly as you can why that change I mentioned a moment ago was made, why in other words did the cross-licensing agreement at that point give up the inclusion of patents thereafter to be acquired?

Mr. REEVES. Well, it seemed to be pretty generally agreed that the 10-year period had worked very well, that it had been quite an extraordinary thing, not only to put in the patents, but to put in anything we were going to get during the next 10 years, and there was a little doubt whether we wanted to do that for another 5 years in the belief that somebody might get out some very good patents they wanted to keep for themselves; however at the end of that 5 years when the agreement was renewed again they did put in all the patents that had been taken out during that 5 years.

Mr. Cox. Your last remark brings us to the extension that was made in 1930, and would it be correct to say that after that extension it applied only to patents which were held by the members as of January 1, 1930?

Mr. REEVES. Yes; patents for the 15-year period.

Mr. Cox. And that extension was for a term of 5 years?

Mr. REEVES. Yes.

Mr. Cox. Another extension was made in 1935, is that a fact?

Mr. REEVES. Yes.

Mr. Cox. And that extension applied only to patents held by the members on January 1, 1930, did it not?

Mr. REEVES. Yes, that is right; yes; in 1935 the agreement was extended to 1940, and included only the patents that were in up to 1930. We didn't take in the new 5-year period patents.

Mr. Cox. Would it be correct to say beginning then in 1935 some of the members of the association began to feel that they had some patents that might be valuable and they might acquire some patents which might be valuable and they didn't wish to put them into this cross-licensing agreement?

Mr. REEVES. I think that might be so.

Mr. Cox. Going back to the period between 1914 and 1925, when all patents except the B patents and the class you mentioned with respect to trucks were included in the agreement, can you tell us what the effect of that agreement was in the industry so far as patent litigation was concerned?

Mr. REEVES. There wasn't a patent suit among the members in 22 years.

Mr. Cox. Do you recollect whether any of the members ever sued anyone who was not a member of the association for infringing a patent held by a member?

Mr. REEVES. I couldn't answer that, but I don't think there was.

Mr. Cox. Do you have any opinion, Mr. Reeves, as to the general effect that that cross-licensing agreement had on the industry in terms of productivity and price in the period between 1914 and 1925?

Mr. REEVES. I think it is generally agreed that it tended to throw the automobile industry open to broad competition with rewards going to the companies that made the best product, sold at the lowest

price, but with an opportunity to every company to make a car based on the best that the art knew about at the time.

Senator KING. It gave every company, then, the same advantages as every other company?

Mr. REEVES. Quite right, Mr. King; any company that started in business could take a membership in the association, which was open to them, and receive all these licenses whether or not he had any patents to put in on his own account.

Senator KING. New companies, then, could avail themselves of that generous provision.

Mr. REEVES. That is right. And in the original agreement I think I ought to point out there were many companies that came in that had no patents at all and the company that had the greatest number of patents was the Maxwell Co., which put in 110; the Studebaker Co. put in 55. The average was about 4 or 5 from the other companies.

The CHAIRMAN. What would you say as to whether or not this policy had the effect of standardizing the manufacture of automobiles?

Mr. REEVES. I don't think that is true, Senator. In every factory there was a fight on constantly to make changes, to make their car just a little bit better than somebody else's car and sell it at a low price if they could.

Mr. PATTERSON. Mr. Reeves, very specifically why did the two members refuse to participate in the cross-licensing arrangement?

Mr. REEVES. Mr. Patterson, one of them felt, I believe, that they had some patent that they thought shouldn't go into the agreement, and I think you can get that from that manufacturer himself, and another manufacturer had practically all the patents on what we call air-cooled motors at that time and felt he wanted to keep it to himself.

Mr. COX. One of those manufacturers was the Packard Motor Car Co., wasn't it?

Mr. REEVES. Yes, sir.

Mr. COX. Will you tell us what the other one was?

Mr. REEVES. Franklin, which afterward, by the way, came into the agreement.

Mr. COX. Will you tell us now, Mr. Reeves, how many patents were put into the cross-licensing agreement in 1915?

Mr. REEVES. Originally there were 547.

Mr. COX. You might just trace the chain from there.

Mr. REEVES. There were 547 patents in the first agreement, 1,066 in 1925, 1,687 in 1930, and 1,285 in 1935, and at the present time there are 1,058 patents that are still alive in the agreement.

Senator KING. Some of those expired?

Mr. REEVES. Yes, sir.

Mr. COX. Mr. Reeves, you said in your opinion in the period between 1914 and 1925 the cross-licensing agreement had the effect of increasing productivity in the industry and probably of lowering price.

Mr. REEVES. That is right.

Mr. COX. Do you have any opinion as to what the effect was from 1925 on of excluding the patents that were thereafter to be acquired in terms of productivity and price?

Mr. REEVES. I don't think it made any difference.

Mr. COX. Why do you think it didn't make any difference?

Mr. REEVES. Because I think they all kept on making the best cars they could. The atmosphere created by this cross-licensing plan was pretty well still in effect, and is today.

Dr. LUBIN. Mr. Reeves, I wonder if you could tell us whether you have any idea as to number of patents now held and being used in the manufacture of automobiles that are not subject to the cross-licensing agreement?

Mr. REEVES. You mean all outside patents?

Dr. LUBIN. That are being used today.

Mr. REEVES. If I may be permitted I will ask Mr. Arvedson, our patent attorney, to answer.

Mr. ARVEDSON. We have no figures that would show that.

Mr. COX. There was a point in the development of this cross-licensing agreement, was there not, Mr. Reeves, where patents held by subsidiaries were excluded from the operation of the cross-licensing agreement.

Mr. REEVES. Yes.

Mr. COX. Why was that done?

Mr. REEVES. Because it had largely to do with the parts and accessory people and because a company happened to own an accessory company it didn't seem fair to bring the patents of that company into the agreement and permit all the members in the agreement to have made by other companies, under the licenses, the same article.

Mr. COX. Those patents, even though they were owned by a wholly owned subsidiary, were excluded from the cross-licensing agreements?

Mr. REEVES. Yes, if they were parts; not if they were cars or trucks.

Mr. COX. Has it been your experience that any of the members of the parties to the cross-licensing agreement have assigned or transferred patents to their subsidiaries in order to avoid the inclusion of those patents?

Mr. REEVES. No; nothing like that.

Mr. COX. No practice of that kind has ever developed?

Mr. REEVES. No.

The CHAIRMAN. Have you any idea how many such accessory patents are owned by subsidiaries of companies which are in the agreement?

Mr. REEVES. I can't tell you that. We haven't that record, but some of the companies that had subsidiaries might be able to tell you.

Mr. COX. Do you think there is any substantial number?

Mr. REEVES. There might be.

Representative SUMNERS. Mr. Reeves, if this is a good thing, why didn't they put into the agreement the patents that somebody wanted to use? I mean these patents on parts controlled by subsidiaries that somebody else might want to use. As I understand your explanation, the reason they didn't put them in was because somebody might want to use them.

Mr. REEVES. Somebody might want to make them, by an outside concern, in opposition to the company that owned them.

The CHAIRMAN. You make a distinction between accessories and parts, do you not?

Mr. REEVES. Naturally.

Representative SUMNERS. What is the difference? I didn't know there was one.

Mr. REEVES. Accessories generally include lamps and things of that kind that go on the car, and parts generally are things that go in the car, such as crankshafts, sliding-gear transmissions, and things of that kind.

Mr. COX. Isn't it a fact, Mr. Reeves, that some of the parties to these cross-licensing agreements refused to go along and put those accessory patents in from time to time when request for renewals came up?

Mr. REEVES. Yes; there was a feeling it was unjust to ask them.

Mr. COX. How many members of the association are there now, Mr. Reeves?

Mr. REEVES. Thirty-four.

Mr. DOUGLAS. What does it cost per year to join?

Mr. REEVES. The initiation fee is \$500, but that applies on your dues, and the dues are based on production at the rate of one-tenth of 1 percent for the first \$20,000,000 worth of business, and then a sliding scale up to \$100,000,000 worth of business.

Mr. DOUGLAS. Net or gross?

Mr. REEVES. Net.

Mr. COX. I think you should explain that those dues are payable by units within the companies.

Mr. REEVES. Yes; they are payable by units in the company. That is to say, Buick and Chevrolet, while they are General Motors institutions, are both individual members in the association.

Mr. DOUGLAS. What other general membership requirements are there?

Mr. REEVES. None, except as a matter of custom. They require that the companies should be in production for at least a year. That hasn't always been followed out; in the case of Dodge Bros., when they had a great big factory under way, but hadn't made any cars, they were admitted before they made cars because we knew they were in the business substantially.

Mr. PATTERSON. What is your potential membership?

Mr. REEVES. The only concerns outside of the Automobile Manufacturers Association now are Ford, Bantam, which have been invited, and a limited number of small truck companies who do mostly a local business.

Mr. PATTERSON. What percent would you say of the potential membership do you have today?

Mr. REEVES. That is all, I should say; outside of Ford, we have got all the balance except these few companies.

Mr. COX. A little while ago I asked you a question about the effects of the cross-licensing agreement. Has it been your experience that that had any effect upon the industry since that eliminated industrial espionage? Do you understand what I mean by that term?

Mr. REEVES. Entirely so. There was never the slightest reason for one company to have a spy in the plant of another company, because they all walked through one another's plants whenever they wanted to and could see all the machinery they had.

Mr. COX. Has that always been true?

Mr. REEVES. Always been true.

Mr. COX. Was it true when you first began to work on this cross-licensing agreement?

Mr. REEVES. Yes, sir; it was pretty true then. There have never been many secrets about the automobile business.

Mr. COX. Then the cross-licensing agreement didn't do much to eliminate that practice if it didn't exist before the licensing agreement was made.

Mr. REEVES. No; but it improved the relationship.

The CHAIRMAN. Why did you refer, then, to that practice of spies in factories?

Mr. REEVES. Well, because we know that in many industries we hear about men being in there to report on activities of the plant, and there is nothing like that in the automobile business because the factories are wide open for you or anybody to walk through, as well as competitors. They invite them over at frequent intervals when they have meetings; they invite men over to see some new process.

The CHAIRMAN. But you have heard of the other practice being followed in other industries.

Mr. REEVES. I have; yes, sir.

Mr. COX. Mr. Reeves, do you think that this cross-licensing agreement as it operates today is a matter of much importance in the motor-car industry?

Mr. REEVES. Well, I think so. Of course, as a manager I may speak quite differently from what a patent attorney may speak, or somebody else, but I might say as a matter of trade association it has created a very fine spirit among the members and a very helpful spirit which couldn't but be beneficial for any industry to have.

Mr. COX. Do you think that the patents that are now included in the cross-licensing agreement are of any particular value?

Mr. REEVES. Some of our patent attorneys say they are not of great value now.

Mr. COX. The patents are now not of much consequence, so you think the benefits of the cross-licensing agreement at the present time so far as they exist are what might be described as psychological or spiritual rather than benefits that can be described in terms of patent law.

Mr. REEVES. I should say that.

Representative SUMNERS. We can't hear you.

Mr. REEVES. The gentleman asked whether or not the patents that are now in the cross-licensing agreement could be considered of great importance. The answer to that is, we can't tell unless they are tested out, but there is a feeling that the patents that are in here now are the latter-day patents and are not as important as the patents that were in in the early part of the industry.

Representative SUMNERS. The ones that were in there in the early part of the industry are not there now because of expiration of time.

Mr. REEVES. That is right.

Mr. COX. The early patents in the early agreements have expired. The only patents that are in the agreement now are patents which the companies held as of the 1st of January 1930.

Mr. REEVES. Yes.

Mr. COX. At this point, I should like, for the sake of the record, to put in some of these agreements. I will just hand these to you,

to save time, and ask you to identify them as accurate copies of agreements of extensions.

Mr. REEVES. They are.

The CHAIRMAN. They may be marked.

(The agreements referred to were marked "Exhibits Nos. 95 to 98," inclusive, and are on file with the Committee.)

Senator KING. Would you say that the policy of exchange of these licenses was advantageous particularly to the new companies which came in and which had a limited number of patents?

Mr. REEVES. I think that is certainly true. It is certainly true because they came in immediately free from any possibility of patent action, and the number of patents they had didn't enter into it. They simply put in what they had as against what all others had in. By the way, Senator, the patents are not given up by a manufacturer. He only grants licenses on them. He can license airplanes on the outside, or Diesel engines, or any kind of apparatus that he wants to; it has nothing to do with this.

The CHAIRMAN. Does your licensing agreement still contain that clause, excluding class B patents?

Mr. REEVES. No; because it wasn't necessary, Senator, in view of the fact that the present agreements don't call for putting in future patents; they only call for patents that are already known.

The CHAIRMAN. If a revolutionary patent were issued now, one that would make it possible, for example, to build a car which would operate much more efficiently upon an altogether different principle, then, in that event, in your opinion it would be beneficial to the entire industry if that patent were made available to all manufacturers.

Mr. REEVES. Of course, it might be, but as far as that patent was concerned, the manufacturer who brought it out now would have it for himself to do with as he pleases.

The CHAIRMAN. Yes; that is clear from what you said, but I am trying to get an expression of your opinion, based upon your experience with this cross-licensing system as to whether or not it would be of advantage to the entire industry to have such a patent available to all.

Mr. REEVES. I think I would be a little bold to answer that. I think the answer ought to come from some manufacturer who might get such a patent.

Senator KING. It would depend entirely, would it not, upon its utility, whether or not it would cheapen the manufacture of automobiles or introduce features which were considered advantageous in the automobile industry.

Mr. PATTERSON. I should like to ask for the record this question: No patents have been added to the pool since 1930?

Mr. REEVES. None have been added since 1930.

Mr. PATTERSON. Isn't it likely that today there are many, many more patents outside of the pool than there are in and subject to the agreements?

Mr. REEVES. Owned entirely outside the pool?

Mr. PATTERSON. Outside the pool.

Mr. REEVES. Oh, yes; thousands.

Mr. PATTERSON. What is your plan for taking care of those?

Mr. REEVES. I don't think there is any plan that can be followed.

The CHAIRMAN. In other words, then, this cross-licensing agreement refers only to the basic patents and as they run out, the agreement is gradually disappearing.

Mr. REEVES. That is the way it is working now.

Mr. PATTERSON. Mr. Reeves, could not the cross licensing group act in restraint of trade by mutually agreeing not to use a basic patent?

Mr. REEVES. To agree among themselves?

Mr. PATTERSON. Yes.

Mr. REEVES. I suppose they might, but if you get a good basic patent, you will get a lot of manufacturers who will be very glad to take a license from you, and very quickly.

Dr. LUBIN. Mr. Reeves, what in your opinion is the reason for these manufacturers refusing to enter into a cross-licensing agreement in 1930 and 1935, of the type that existed earlier, which would provide for making new patents available to their competitors?

Mr. REEVES. Because I think that there was a good deal of research work going on, proving grounds had been established by a number of companies, large sums of money were being spent, and it was recognized that it was hardly fair under those circumstances to have the new patents included as they come out, providing new ones were coming out, but there haven't been so very many.

Dr. LUBIN. Do you think that the fact that 1930 was a depression year and the market was relatively limited might have had something to do with this unwillingness, due to the fact that each company felt that it would like to hold on to such patents as it had for itself so as to get as big a share as it possibly could of the restricted market then existing?

Mr. REEVES. I don't think that; I don't think that they expected that the patents were going to help them during those next couple of years do much about the market. I think what they felt about the market was that they had to get a car low down in price—of better quality than before in order to participate in it.

Dr. LUBIN. Yes; but the holding of your own patents and not sharing with your competitors would make it possible for you to do that and get a bigger share of the limited market than you would get if you shared the patent.

Mr. REEVES. If the patents were really of great importance, but there weren't any developing at that time.

Representative SUMNERS. This testimony that is being offered seems to indicate that it is valuable to have this interchange of the right to use a patent. You have been testifying with reference to this group agreement under which there is an interchange of the right to use a patent. That is supposed, I presume, to be valuable to the industry and to the public. If that is so—and I am not asking this in any argumentative sense—then why should there not be a general and, if necessary, compulsory interchange where proper compensation is made of the right to use a patent?

Mr. REEVES. I couldn't answer that, Judge, because I am no judge of what other industries require. It might be in other industries that it is not necessary to interchange patents. It happened in the automobile industry, which was a very broad one, which involved many

patents, many of them old, all put together to complete a motor vehicle, that it worked very well.

Representative SUMNERS. Of course, if you just used second-hand patents that were worn out, it didn't hurt anybody or do anybody very much good; but to the degree that you did have some valuable patents and it was a good thing—well, I think I won't press it. Well, I don't know; I am not getting much information on the point that I am particularly concerned about. What I want to know is what we are going to do about it and what we ought to do about it.

Mr. REEVES. We have got to get a good deal more evidence in from all the companies.

Representative SUMNERS. I don't believe we will get a smarter witness here before we get through.

Mr. REEVES. I hope I will bear that out.

Mr. ARNOLD. Could I direct your attention possibly to an industry by an industrial approach to the facts, using this analogy. I presume under some circumstances a corporate merger would be a reasonable restraint of trade. Under other circumstances, the use of that same device would be an unreasonable restraint of trade. You would agree there, would you not?

Mr. REEVES. Yes.

Mr. ARNOLD. Isn't it true that by the same token the use of another legal privilege, the patents, might be in some circumstances a completely unreasonable restraint in the development of an industrial art and in other circumstances it might be mere compensation for development work, and that that might be treated as a question of fact which would differ in different industries? Would you think that that would be a possibility?

Mr. REEVES. I should think that would be more of a legal question and I wouldn't have the ability to answer, Mr. Arnold.

Mr. ARNOLD. I wasn't intending to make it a legal question. I was only intending to ask you whether as a businessman you conceived of the use of the patent being not in a legal sense but in an economic sense, an unreasonable restraint of trade if it were used in such a way that it did create a monopoly privilege, and reasonable in a business sense if it were used in such a way that it only compensated for the development for the inventor, and so on, and that determination of whether it was economically reasonable or unreasonable might be a question of fact which varied in different circumstances.

Mr. REEVES. I should think that would be true.

Senator KING. The purpose of the constitutional provision and of the law itself is to give a monopoly to the patentee. Now, he may or may not use that patent. He may hide it under a bushel or he may exploit it, as he sees fit, and in the utilization of the patent per se he is not violating the Sherman antitrust law because he has a monopoly on that patent.

Mr. ARNOLD. I would not wish to discuss the law on that. I would only indicate that from an economic point of view, the use of any legal privilege in such a way that it actually restrains the development of industrial arts might be a question of fact and conceivable machinery might be set up to treat the patent problem much as you treat the merger problem. I don't wish to take any position; I am only suggesting that in answer to Congressman Sumner's query as to where this particular hearing might be leading us.

The CHAIRMAN. That is a question of policy, is it not, Mr. Arnold?

Mr. ARNOLD. Yes; and it is a hearing directed somewhat at questions of that kind.

Mr. COX. Mr. Reeves, I would like to ask you some questions about the state of affairs while the agreement was in the form which existed between 1914 and 1925. Is it not a fact that if any of the companies who were parties to the agreement at that time bought a patent from an inventor or some other person outside the cross-licensing agreement, that patent had to be put in under the agreement?

Mr. REEVES. Yes.

Mr. COX. So that a company presented with an opportunity for purchasing a patent from an inventor could get no competitive advantage by that purchase as against his competitors who were parties to the cross-licensing agreement?

Mr. REEVES. Yes.

Mr. COX. Do you think that situation was a healthy one from the point of view of the inventor who was trying to sell a patent to someone?

Mr. REEVES. I think Mr. Arvedson can answer that.

Mr. COX. I want you to answer it.

Mr. REEVES. He said "yes" and I rather agree with him.

Mr. COX. Do you think an inventor in that situation was really peddling his invention in a competitive market?

Mr. REEVES. He didn't have to sell it, you know. He could have licensed them. He could have licensed them and he couldn't license them exclusively. He had to license everybody that wanted a license. That was his protection.

Mr. COX. Didn't it present an opportunity for all of the members of the cross-license agreement to agree even as to the license fee which they paid to the inventor?

Mr. REEVES. It might, but there were no such instances that came up. The provision was that if a manufacturer took a license he couldn't take an exclusive license, which would bar the other members in the agreement from having the same kind of agreement with the inventor, so the inventor had the entire industry to deal with, and under those circumstances he certainly wouldn't want to sell patents to one company unless he got a very high price for it.

Mr. COX. The inventor couldn't have given anyone an exclusive license under that situation, because no one would have taken it from him.

The CHAIRMAN. But it can be done now with respect to new patents, and the only distinction you make between the old policy and the new policy is that modern patents are not particularly important.

Mr. REEVES. There haven't been so very many, but you never can tell when something new and fine is going to come out.

The CHAIRMAN. You were unwilling to express an opinion as to what should be done if an important patent should develop.

Mr. REEVES. I think that is for the man who has the patent to decide.

The CHAIRMAN. What I had in mind was to get the benefit of your judgment as a man who has been intimately associated with the use of this policy as to whether or not in your opinion it is a policy that ought to be maintained.

Mr. REEVES. In view of the fact that the industry has always been more of an industry of competition in manufacturing and selling, with patents not considered so important, I think that members of the industry might say that they think it was fine if they all had an opportunity to make use of it.

The CHAIRMAN. You may recall when Mr. Ford was on the stand I asked him whether he cared to make a statement to the committee as to whether or not he would recommend this free licensing policy to other industries.¹ Would you care to answer that question?

Mr. REEVES. I think it would depend on the industry. I think it is well worth their making a study of it, in view of the way it is operating in our industry.

The CHAIRMAN. But your testimony to this committee is that so far as it has gone it has been beneficial.

Mr. REEVES. That is right.

Mr. PATTERSON. One other point upon which I am not quite clear is this: Are the companies in this cross-licensing arrangement under agreement not to offer their patents to companies who are not included in this group?

Mr. REEVES. Oh, no. They can offer their patents to anybody they want to. All they are doing is granting a license to those who grant licenses to them.

Mr. PATTERSON. No verbal understanding?

Mr. REEVES. Not a thing; oh, no—nothing of that kind.

Mr. Cox. They can grant a license to someone outside a cross-licensing agreement?

The CHAIRMAN. It is an agreement for mutual exchange without any restrictions upon the other users.

Mr. REEVES. And without any exchange of money. There is no money royalty involved of any kind. It is a quid pro quo. A man puts in all he has and he gets all the others have, and the percentage is very much in his favor when it is done that way.

Representative SUMNERS. Mr. Reeves, I didn't exactly understand your answer to one of Mr. Cox's questions. Here is an inventor. He has devised something of value to the automobile industry. There are 30 persons, each of whom might want that. This agreement excludes from the possibility of making a deal with him all except one, because if one makes it, he buys it for the benefit of all. Is that right?

Mr. REEVES. If he buys it; but if he only takes a license under it, then every other manufacturer, in order to compete, would have to take a license from him. No manufacturer can take an exclusive license for himself, barring the other manufacturers who are in the agreement, and that is in the old agreement. In the new agreement he can do anything he wants to.

Representative SUMNERS. But each manufacturer would have to go to the same source for his right.

Mr. REEVES. The inventor has the right to grant licenses to 50 manufacturers if they all want it.

The CHAIRMAN. Was there any discussion in the organization at the time the policy was changed as to the merits of these two different policies?

Mr. REEVES. I don't think that anything came up except the fact that

¹ See supra, p. 284.

a great deal of development work was going on. Everybody hoped that they would have something that would be a little better than somebody else's, so they said: "We will renew the agreement with the patents that are now in"; but at the end of 5 years, when they had looked over all the patents that had come out during that period, they said, "There is nothing here that is so important but what we all ought to put them in"; and they did; so the agreement affected patents over a 15-year period; and it was then, in the next agreement that came along, where they said: "New developments are going on, and it seems only fair that companies that are spending great sums of money in development work and testing and things of that kind might be entitled to some special rights under it"; so they agreed to go along with the agreement as it was, with nothing new coming in.

The CHAIRMAN. Well, then, are we to understand that these automobile manufacturers are abandoning this policy?

Mr. REEVES. No, indeed. The present agreement does not expire until 1940.

The CHAIRMAN. But I mean with respect to all patents which are not included within that policy you are abandoning it.

Mr. REEVES. They may, in 1940, when that comes up, decide to put them all in.

Mr. DOUGLAS. They abandoned it in 1935, when you didn't include them in the new agreement.

Mr. REEVES. Yes; for the future patents. All the old patents are in.

The CHAIRMAN. That is a very important factor of this original agreement. Your original agreement extended to existing patents and to all future patents. Now your agreement extends only to existing patents.

Mr. REEVES. Right.

Senator KING. Did it extend to all future patents for an indefinite period, or was it not circumscribed or limited by a 5-year period?

Mr. REEVES. Ten-year.

Senator KING. It was only for 10 years, not for all time?

Mr. REEVES. That's right.

Mr. COX. It is a fact, isn't it, Mr. Reeves, that the patents that are in the cross-licensing agreement today are not important patents?

Mr. REEVES. I think Mr. Arvedson¹ is a better judge of that.

Mr. ARVEDSON. I don't know.

Mr. REEVES. He says he doesn't know.

Senator KING. They have been important, have they not, in the development of the industry?

Mr. REEVES. There has been that feeling; yes.

Senator KING. And they are being utilized now?

Mr. REEVES. I think so.

Senator KING. Some of them are primary patents, in contradistinction to subsidiary patents, accessory to or appendages to the primary patents?

Mr. REEVES. I think some of the later witnesses can tell you how many patents they are using under the cross-licensing agreement and owned by other manufacturers, and how many are using their patents.

Mr. COX. Could you tell us now, Mr. Reeves, from any material you have there, how many of all the patents that are issued relate to the automotive industry? Does your book have any figures on that?

¹ George C. Arvedson, chief of Patent Section, Automobile Manufacturers Association.

Mr. REEVES. I think Mr. Arvedson can give us those figures.

Mr. COX. Look on page 43.

Mr. REEVES. Total automotive patents to date is 298,000. Nineteen percent of all the patents issued are automotive patents. With 1,564,000 patents, 298,000 plus are automotive patents.

Senator KING. You understand there are only about 700,000 patents still alive. Do you know what proportion of that 700,000, assuming I am correct in giving that figure, are still alive?

Mr. REEVES. I couldn't tell that, sir.

Senator KING. How many of the patents that are still alive are owned or involved in your cross-licensing—19 percent, did you say?

Mr. REEVES. One thousand fifty-eight live patents are in the cross-licensing agreement at the present time.

Mr. COX. I may say it is a little difficult to compare that figure, but it appears from the figures which have been prepared by Mr. Reeves' organization that there are probably roughly about 175,000 patents in existence today which relate to the automotive industry.

The CHAIRMAN. It would be interesting to know how many of those are merely accessory patents in which manufacturers were not interested when they were making this cross-licensing agreement and how many of them are patents applying to parts used in the manufacture of motor cars and trucks.

Mr. REEVES. I don't think there has ever been any check on that.

The CHAIRMAN. Obviously, the ten-hundred-odd patents which are in the cross-licensing agreement are only a small proportion of the number of patents which have been actually issued.

Mr. REEVES. Right. It had to do only with the members of the association.

The CHAIRMAN. Oh, I see. The total figure, in excess of 170,000, applies to the patents of all kinds issued to all sorts of persons, individual inventors, and so on, not necessarily engaged in the manufacture of automobiles.

Mr. REEVES. That is right.

Mr. COX. They are all patents which relate to the automotive industry in one way or the other.

I believe, since this question as to the number of patents has been raised, that it might be well to offer for the record one page from a publication of the Automobile Manufacturers Association entitled "Automobile Facts and Figures, Edition for 1938." The page shows the number of patents issued year by year since 1899 and percentage of those patents each year as related to the automotive industry.

The CHAIRMAN. You want that inserted in the record at this point?

Mr. COX. Page 43 of the booklet I have just described.

The CHAIRMAN. Without objection, it is so ordered.

(The page of the booklet referred to was marked "Exhibit No. 99" and is included in the appendix on p. 684.)

Mr. REEVES. It is a book distributed annually to anybody who is interested in the industry.

Mr. COX. In order to save time, I should also like to have you identify this schedule and ask you whether it is an accurate statement of the number of manufacturers who belong to the cross-licensing agreement.

Mr. REEVES. Yes, sir.

Mr. COX. And is this an accurate statement of the names of the companies?

Mr. REEVES. Yes.

Mr. COX. With the chairman's permission, I should like to have those marked.

The CHAIRMAN. They may be marked as exhibits.

(The two schedules referred to were marked "Exhibits Nos. 100 and 101," respectively, and are included in the appendix on pp. 685, 691.)

Mr. COX. I think I have probably concluded with the witness.

Mr. PATTERSON. What advantage has the A. M. A. cross-licensing arrangement over the free and unrestricted policy of the Ford Co. as outlined by Mr. Ford this morning? In other words, your system over the Ford system?

Mr. REEVES. The difference between the Ford system of licensing and the A. M. A. system of licensing?

Mr. PATTERSON. I want the advantages, Mr. Reeves, if that is a fair question.

Mr. REEVES. The advantages of the A. M. A. system over the Ford system?

Mr. PATTERSON. The unrestricted licensing policy.

Senator KING. That is the difference between a patent system and having no patent system.

Mr. REEVES. Mr. Ford said they reciprocate with anybody on patents, and that is what this is, a reciprocal arrangement. The only thing is that Mr. Ford participates with one company. It is held to that, whereas this provides that a member signing the agreement enjoys the patents of all the other companies.

The CHAIRMAN. The Chair has been advised that the next witness that Mr. Cox planned to call is very anxious to conclude this evening and leave, so if it is agreeable to you, Mr. Cox—

Mr. COX (interposing). I have finished with Mr. Reeves.

The CHAIRMAN. If there are no other questions by members of the committee—

Mr. DOUGLAS (interposing). Have you got for the record, Mr. Reeves, an income statement of the association, showing how much its annual income is and how much its annual expenditures are? ¹

Mr. REEVES. Yes, sir. I will be glad to file it.

Mr. COX. Do you have it here now?

Mr. REEVES. No; I will be very glad to get a copy and file it.

The CHAIRMAN. We are very much indebted to you, Mr. Reeves, for your testimony.

Mr. REEVES. Thank you gentlemen very much for your courtesy. Thank you, Mr. Cox.

(The witnesses were excused.)

The CHAIRMAN. Now, Mr. Cox, if you will call the next witness.

Mr. COX. I think here again you might swear Mr. Macauley and Mr. Tibbetts at the same time.

The CHAIRMAN. Do you and each of you solemnly swear the testimony you are about to give in this proceeding will be the truth, the whole truth, and nothing but the truth, so help you God?

Mr. MACAULEY. Yes, sir.

Mr. TIBBETTS. I do.

¹ Mr. Reeves subsequently submitted a statement of income and expense for the year ended June 30, 1938, which was entered in the record at hearings on February 28, 1939, as Exhibit No. 302, and is included in the appendix, infra, p. 802.

TESTIMONY OF ALVAN MACAULEY, PRESIDENT, PACKARD MOTOR CAR CO., DETROIT, MICH.; AND MILTON TIBBETTS, VICE PRESIDENT AND PATENT COUNSEL, PACKARD MOTOR CAR CO., DETROIT, MICH.

Mr. Cox. Mr. Macauley, will you give your name and address to the reporter?

Mr. MACAULEY. Alvan Macauley, Detroit, Mich.

Mr. Cox. And Mr. Tibbetts?

Mr. TIBBETTS. Milton Tibbetts, Detroit, Mich.

Mr. Cox. Mr. Macauley, you are president of the Packard Motor Car Co.?

Mr. MACAULEY. Yes.

Mr. Cox. How long have you been connected with the Packard Motor Car Co.?

Mr. MACAULEY. Twenty-eight years; twenty-eight and a half, to be exact.

Mr. Cox. Is your company a member of the Association of Automobile Manufacturers?

Mr. MACAULEY. Yes, sir.

Mr. Cox. How long has it been a member of that association? [No response.]

Mr. Tibbetts, will you tell us what your present occupation is?

Mr. TIBBETTS. I am at present vice president and patent counsel of the Packard Motor Car Co. I have been with the company since 1907.

Mr. Cox. Have you ever been a party to the cross-licensing agreement administered by the association?

Mr. MACAULEY. No.

Mr. Cox. Will you tell us briefly now why you have never been a party to that agreement?

Mr. MACAULEY. Well, my best recollection is that at the time it was proposed, for years back of that, we had been doing a great deal of engineering and development work. We were one of the very early companies in the business, our operations having begun in a formal way about 1898, 40 years ago, or something like that, and we had acquired and devised a number of patents of considerable value in those early days, and measuring what we had against what the other fellows had combined we felt it wasn't a good thing for us to go into.

Mr. Cox. And you have adhered to that opinion in the interval of time since?

Mr. MACAULEY. At any rate we haven't joined.

Mr. Cox. Can you tell us now how many patents your company owns at the present time?

Mr. MACAULEY. About a thousand active live patents.

Mr. TIBBETTS. Ten hundred thirty-eight.

Mr. MACAULEY. We own, however, 1,485, all but 1,038 of which have expired.

Mr. Cox. What is your primary purpose in taking out patents?

Mr. MACAULEY. I say it is a defensive measure. If we conceive and perfect a bit of mechanism or device useful in an automobile, and we don't take out a patent on it, it is very likely to happen that somebody later will devise that same thing or substantially the same thing. The later deviser would take out patents on it and we would expect to be notified of an infringement of a device which we had first devised.

THE LICENSE-ROYALTY SYSTEM

Mr. COX. Do you grant licenses to others under your patents?

Mr. MACAULEY. Yes.

Mr. COX. Are those licenses granted royalty free, or do you charge them royalty?

Mr. MACAULEY. Usually we charge royalty.

Mr. COX. Is there any case where you have granted a license royalty free that you recall?

Mr. MACAULEY. Yes; I do remember some.

Mr. COX. It has always been a policy of your company to collect royalties under your licensing agreements?

Mr. MACAULEY. Yes, sir.

Mr. COX. When you grant those licensing agreements is it your policy to include any provisions which restrict the licensee as to the amount of his production or any restrictions as to price?

Mr. MACAULEY. No; there has never been any of that.

Mr. COX. Are there any restrictive provisions of any kind that you put in?

Mr. MACAULEY. We have sometimes differentiated between the use of a patent in automobiles on the one hand and perhaps an airplane motor on the other hand.

Mr. COX. That is a restriction as to the field of use?

Mr. MACAULEY. Yes.

The CHAIRMAN. By that do you mean you would permit it in one field and not in another?

Mr. MACAULEY. Yes; that might happen, too; but in any event it would probably be that the royalty in the one hand would be larger than in the other. We had a very recent negotiation in which the royalty for the use of this device in an automobile engine was something like \$2, but when applied to a modern high-powered aviation engine it was \$148.

The CHAIRMAN. I get the impression from what you say, or rather the manner in which you say it, that the distinction in your mind is merely one of royalty and not one of the manner in which the patent is used.

Mr. MACAULEY. You are right about that.

Representative REECE. Mr. Chairman: On what theory, Mr. Macauley, do you grant some patents royalty free and others not?

Mr. MACAULEY. One that I have in mind was—

Representative REECE (interposing). I am not interested in a particular patent, but in the theory upon which you grant some royalty free and others not.

Mr. MACAULEY. We might have a patent on it, but if it were a trivial sort of thing Mr. Tibbetts would recommend that no charge be made.

Mr. COX. It largely depends on the value of the patent, then?

Mr. MACAULEY. Yes.

The CHAIRMAN. Would you grant a license to a competitor?

Mr. MACAULEY. Yes.

The CHAIRMAN. And you have done so?

Mr. MACAULEY. Many times.

The CHAIRMAN. So the question of competition with you doesn't enter into the determination of the royalty?

Mr. MACAULEY. Not at all.

The CHAIRMAN. Or the granting of the license.

Mr. MACAULEY. When we grant them at all we grant them on a uniform basis to anyone that may apply, generally speaking.

Representative REECE. They are granted on a uniform basis, so that you don't reserve to yourself the privilege of discriminating between various manufacturers as to whether you grant royalty free or not?

Mr. MACAULEY. There are very few cases of royalty free, so far as that goes. I am not perfectly sure that I have your question clearly in mind.

Representative REECE. If you charge a royalty, do you charge the same royalty to all manufacturers?

Mr. MACAULEY. That is generally true. Whether there are any exceptions to it or not I don't know. I don't remember any at the moment.

Representative REECE. I was just going to make one further observation. Do you think you should have the right to grant the patent to one concern without royalty and to another concern with royalty, and to a third concern at a different royalty?

Mr. MACAULEY. Yes; I think we should have the right, if we want to do that.

Mr. Cox. In fact, in these cases you have spoken of, where the license has been granted royalty free, that hasn't been a situation. has it, where you licensed one person under the patent free, and licensed another person under the same patent and charged him a royalty?

Mr. MACAULEY. No.

Mr. Cox. So far as the particular patent is concerned, you treat all licenses alike.

Mr. TIBBETTS. May I explain that a little? Some of the details Mr. Macauley hasn't followed quite as carefully, if I may do this. We sometimes grant a license at a given royalty, and later on we find the patent is of more importance than we thought it was in the first instance, and later applicants are then willing to pay a greater royalty than the first one. We do grant, and have in a number of instances granted, licenses then at higher royalties. Sometimes we have granted licenses at lower royalties, in which case the first ones get the benefit of the lower royalties, because in nearly every license that we have granted, perhaps I could satisfy everyone, there is a clause, and most licensees granted it, what we call a favored-nation clause, which is that if a license is granted at a lower rate, a better rate later on, the first licensee will have the benefit of the better rate.

Mr. Cox. The provision operates so, I take it, that the licensees under a particular patent are all treated alike. There is no situation where one licensee is paying a larger royalty fee for the same patent than another.

Mr. TIBBETTS. That depends somewhat upon the field also. This aircraft-engine field we speak of will frequently pay a higher royalty than the passenger car because of the difference in volume. One runs in the hundreds of thousands, and the other into a few hundred.

Mr. Cox. I will amend the question to say if the patent is used in the same field of use by two licensees, there is no situation in which one licensee is being charged a lower royalty than another.

Mr. TIBBETTS. Generally speaking, that is true.

Mr. Cox. Is it the policy of the Packard Co. to sue persons who use your patents without obtaining a license?

Mr. MACAULEY. We never have sued.

Mr. Cox. Has there ever been an occasion when you sued anyone for infringing your patents?

Mr. MACAULEY. We have never appeared except as a nominal plaintiff or complainant in three cases. We have never been the actual plaintiff or complainant.

Mr. Cox. Was that a situation where you had granted an exclusive license to a third party but you retained legal title to the patent, and the licensees were suing for infringement, and you were joined as a nominal party to the plaintiff?

Mr. MACAULEY. That is right.

Mr. Cox. So, although you grant licenses and obtain royalties if you can, if someone doesn't take a license and doesn't pay royalty fees, you don't sue him?

Mr. MACAULEY. No.

Mr. Cox. You are not saying you never would sue somebody?

Mr. MACAULEY. No.

Mr. DOUGLAS. Why did you institute a policy different from the rest of the industry?

Mr. MACAULEY. I don't know. As a matter of fact, that is the policy of a good deal of the industry. Very few of the other companies have a patent we would like to use they don't charge us for. We have taken, as I recall it, 176 licenses from other companies—a very large number.

Mr. TIBBETTS. We have 49 licenses outstanding now. That is where we are receiving royalties.

Mr. MACAULEY. 176 on the one and 197 on the other, 176 licenses have been granted to us and 197 licenses on our patents have been granted to others.

Mr. Cox. Can you give us an idea of what your income from royalty fees amounts to?

Mr. MACAULEY. That is about how much, Mr. Tibbetts? What is that averaging?

Mr. TIBBETTS. It has averaged over the past 30 years approximately \$125,000 or \$130,000 per year.

Mr. Cox. You will tell us what the licenses which you have taken from others have cost you in license fees and royalty fees?

Mr. TIBBETTS. We have paid \$553,000 in the past years. I haven't divided it up.

Mr. Cox. How many years does that cover?

Mr. TIBBETTS. The past 30 years, since I have been with the company. It is the entire life of the company, practically, because we had not paid prior to that time.

Mr. Cox. Are you often sued for infringing other persons' patents?

Mr. MACAULEY. Very seldom.

Mr. Cox. Can you give us anything to indicate how often that happens?

Mr. MACAULEY. Four times. In one of those cases the suit was dismissed on our showing of the prior art to the complainant; in two cases there was a settlement, so the suits were withdrawn; and the other case is still in court.

Mr. Cox. Those four cases throughout the entire life of the company; is that correct?

Mr. MACAULEY. Yes.

Mr. Cox. Are you threatened with infringement suits from time to time?

Mr. MACAULEY. Yes.

Senator BORAH. Do you carry on research and development work in your organization?

Mr. MACAULEY. Yes; assiduously.

Mr. Cox. Do you have a special department that does that?

Mr. MACAULEY. Yes.

Mr. Cox. Do you spend substantial amounts of money in carrying on that work?

Mr. MACAULEY. Quite substantial.

Mr. Cox. If your company could not obtain a patent on the invention which it makes as a result of that development and experimental work, is it your opinion that that work would still be carried on?

Mr. MACAULEY. Yes.

Mr. Cox. You think it wouldn't make any difference?

Mr. MACAULEY. I wouldn't say it wouldn't make any difference, but we would still carry it on—most of it. Certainly some of it we wouldn't. We very often start on a long blind trail. We don't know where it is going to come out, and we will pursue it if we think it is a novel field of endeavor that might be valuable to the public and to ourselves. We may follow that a long way at considerable expense, with the hope and expectation that at the end of it we will get a certain protection that will in a measure at least reward us for the expense we have undergone in following this long trail.

I am quite sure we wouldn't do that sort of experimental work if there were no patent at the end of it.

Mr. Cox. In a case of that kind, then, when you take out a patent, you don't take a patent purely for protective purposes.

Mr. MACAULEY. No; not altogether. We feel that if we can, if we have something to sell that somebody else wants, if they want to use this new thing we have devised, we have a right to get back a part of what it cost us to do the development work.

Senator KING. As a result of your investigations and experiments and expenditures, have you devised new practices?

Mr. MACAULEY. Yes; many.

Senator KING. And are they being used by any other automobile companies?

Mr. MACAULEY. Evidently, because we have issued a total of 197 live licenses to others and have received from others, as I said, 176 licenses—pretty nearly a balance there.

Mr. PATTERSON. Mr. Macauley, may I ask you this question: Has your company ever availed itself of any royalty licenses offered by the Ford Motor Co.; and if not, why not?

Mr. MACAULEY. We have contemplated it even recently. I don't recall that we ever did; no. To the best of my knowledge and belief, we never have.

Mr. Cox. Mr. Macauley, you were active in the motor-car industry in the early 1900's, were you not? When did you first become active in the industry?

Mr. MACAULEY. In 1899.

Mr. Cox. I will ask Mr. Tibbetts the same question. When did you first become active in the motor-car industry?

Mr. TIBBETTS. May, 1907.

Mr. Cox. Do either of you gentlemen have any recollection as to the patent policy followed by the Ford Motor Car Co. at its inception? I speak of the period before the Selden suit.

Mr. MACAULEY. I haven't.

Mr. TIBBETTS. I know nothing of it.

Mr. Cox. Are either of you gentlemen acquainted with the circumstances which led to the formulation of the first cross-licensing agreement by the Automobile Manufacturers Chamber of Commerce, in 1914?

Mr. MACAULEY. I haven't a very definite recollection of all the circumstances. I have a recollection of the Kardo incident.

Mr. Cox. Will you tell us about the Kardo Co., Mr. Macauley?

Mr. MACAULEY. That was a long, long while ago; in 1914, this was. We had among our applications in the Patent Office one for rear-axle structures, and the American Ball Bearing Co. had another application in, and the Peerless Motor Car Co. had a third application, and they got into interference. We fought up hill and down dale for a while, and finally the interference was terminated. We, each of us, got a patent at any rate, and then the American Ball Bearing said to us that we were infringing their patent, and Peerless said we were infringing their patent, and we said, "Well, we have got one, too, and we think you are probably infringing ours," and that is the way it was for a little while. The two of them came to us and said they had got together, and proposed that we join in order to clear up the situation and to avoid their threat of infringement to us, their respective threats, and we did. We joined up.

We said, "All right, that is a good way to clear it up as far as we are concerned," and they organized what they called the Kardo Co., with a certain group of patents, all relating, however, to rear axles—front and rear; axles, anyhow—and that Kardo was organized and later granted a good many licenses to the industry.

Mr. Cox. That was a case where, after you three companies had been involved in long and, I presume, expensive interference proceedings in the Patent Office, and the patents had issued, you still didn't know what the respective scopes of the different patents were, and you were faced by a long period of litigation; is that right?

Mr. MACAULEY. I don't say we didn't know. We had our opinion about it, but it was somewhat easier to put in our patent with the others than to undertake expensive and troublesome litigation.

Mr. Cox. You decided to put all of the patents in the one company, really a sort of holding company for the patents?

Mr. MACAULEY. That is right.

Mr. Cox. Do you think that circumstance contributed in any degree to the execution of that first cross-licensing agreement?

Mr. MACAULEY. I don't definitely know that it did. I haven't any clear recollection on that.

Mr. TIBBETTS. I don't know, but I have always suspected that that was the principal reason for it.

The CHAIRMAN. It preceded the other agreement.

Senator KING. It was a sort of precedent.

Mr. Cox. What do you think, Mr. Macauley, about the effect that cross-licensing agreement of the association has had with regard to the industry? Do you think it has been a good thing?

Mr. MACAULEY. I think it has been a good thing.

Mr. Cox. Do you think it is still a good thing, in the sense that it now makes very much difference?

Mr. MACAULEY. I think it is a good thing right today.

Mr. Cox. You think the patents included in the cross-licensing agreement are of any particular importance, or do you have an opinion about that?

Mr. MACAULEY. I have just an impression. I don't know of any outstanding ones, no, that are included. Of course, it is much more difficult today to get an outstanding patent or important patent or valuable patent than it was years ago when the industry was young. It has been refined and developed today so that, to a considerable extent, inventive talent is directed to the smaller features, not so important.

Mr. Cox. I think that will be all.

The CHAIRMAN. Mr. Macauley, does the Packard Co. use any of the 1,000 patents which are in the cross-licensing agreement?

Mr. MACAULEY. We have the 1,000. We use our own patents, if that is what you mean.

The CHAIRMAN. I am not asking about that. Of course, you use your own. Mr. Reeves just testified that at the present time there are some 1,000 patents in the cross-licensing agreement. Do you know whether or not the Packard Co. uses any of those patents?

Mr. MACAULEY. Not to the best of my knowledge. Mr. Tibbetts would be a better authority on that than I.

Mr. TIBBETTS. I don't think we do, unless possibly it is some of those under which we are licensed by the companies which hold them.

The CHAIRMAN. You do hold some special licenses? What I am trying to get at is some knowledge of to what extent the really basic patents of the automobile industry were the foundation of this cross-licensing agreement. It has been testified that, as the patents expire and therefore lapse, they pass out of the agreement, and that the association is not now making new patents the basis of the cross-licensing system, or bringing them in the cross-licensing system. What I am trying to find out is whether or not, at the time this cross-licensing agreement was first effected, there were any basic patents which were in the cross-licensing agreement which you didn't use.

Mr. MACAULEY. Well, I don't think there were an awful lot of important patents in it.

Mr. Cox. At any time?

Mr. MACAULEY. No.

Mr. Cox. Do you think that an agreement had any more beneficial effect in the period between 1914 and 1925, when it included all patents, including those thereafter to be acquired, than it has today? Do you understand that?

Mr. MACAULEY. Will you ask that again?

Mr. Cox. I will restate the question. What I wish to know is this: I assume from your previous answer that you think that, for the period between 1914 and 1925, the cross-licensing agreement had a beneficial effect upon the motorcar industry? Would you say that

that beneficial effect was of more importance than the effect of the agreement is today?

Mr. MACAULEY. Yes, sir.

Mr. COX. Is that because the patents which were under the cross-licensing agreement at that time were more important than the patents are today?

Mr. MACAULEY. I would say yes.

Mr. COX. Would one of the reasons for your answer also be that that was a period during which the art in the industry was developing in a more basic sense than it is today?

Mr. MACAULEY. Yes.

Mr. COX. Has it been your experience in all the years you have been in the motorcar industry, Mr. Macauley, that the manufacturers in the industry paid a great deal of attention to patents in the sense of attempting to enforce them against each other?

Mr. MACAULEY. No; they haven't.

Mr. COX. Do you have any explanation for that?

Mr. MACAULEY. Why, no. I think they were an awful nice lot of fellows.

Mr. TIBBETTS. That has more to do with it.

Mr. MACAULEY. Nobody was trying to pirate somebody else's patent. If we looked over the field and found we encountered some General Motor's patent, we would go to them and say, "It looks like we have been infringing this. Will you give us a license?" And if the conditions were reversed, we gave them a license.

Mr. ARNOLD. No situation ever developed in the motorcar industry where people who didn't manufacture had substantial control of patents, did there? That is, nonmanufacturing control of patents didn't develop, did it?

Mr. MACAULEY. I don't remember many cases of that kind.

Mr. ARNOLD. And, therefore, the people dealing with the patents were primarily interested in production and not in getting an income from patents?

Mr. MACAULEY. That is true.

Mr. ARNOLD. And isn't it true that that probably is one of the reasons why manufacturers did not emphasize patents as a source of income?

Mr. MACAULEY. Undoubtedly.

Senator KING. In all the licenses you have issued, you have only got in 30 years—

Mr. TIBBETTS (interposing). \$4,099,707 and have paid out \$553,401.

Mr. MACAULEY. That, of course, didn't include the cost of getting the patent.

Mr. COX. Will you give us some rough idea of what percentage that income from royalties bears to the rest of your income?

Mr. MACAULEY. I don't know. Our earnings have been as high as \$25,000,000 a year, so it is negligible.

The CHAIRMAN. Your chief concern in getting patents then is rather to protect your company against exploitation by some other person who might patent the devices.

Mr. MACAULEY. That is quite right.

Mr. DOUGLAS. On the basis of your experience, Mr. Macauley, would you conclude that the protective period of the patent law should be shortened?

Mr. MACAULEY. No; not the state of the patent, 17 years. I don't think that should be. It often takes many years to perfect a device, even after you have the general principles in mind. I know one cost nearly \$800,000, represented to me; it wasn't a serious thing either, and it took quite a few years to get it so it was workable.

The CHAIRMAN. What would be your opinion with respect to the practice which is sometimes followed of keeping a device in the status of application rather than a patent?

Mr. MACAULEY. I am very much against it.

The CHAIRMAN. In other words, the period during which an application may protect a device, in your opinion, ought to be shortened?

Mr. MACAULEY. No; I think that there shouldn't be the opportunity to keep a device in the Patent Office a long while. Some of them have been there 10 or more years, and they are finally issued for 17 years. In a way, that makes 27 years. I think 17 years is all right. I understand the Commissioner of Patents has a recommendation to limit it so that no patent, including the time of application, shall exceed 20 years.

The CHAIRMAN. You see no objection to that?

Mr. MACAULEY. No.

Senator KING. Hasn't the principal trouble in the Patent Office been the unwarranted and oftentimes improper interference for the purpose of protecting and prolonging the life of the patent?

Mr. MACAULEY. I think there has been some of that. It is a very bad practice, too.

Mr. PATTERSON. Disregarding the question of profits, which system of patent licensing do you consider has been most beneficial to the development of the industry? There are three systems—the Ford system, your system, and the A. M. A. system.

Mr. MACAULEY. The patent system has been of very great value.

Mr. PATTERSON. I don't think you heard the question. Disregarding the profit considerations, which system of patent licensing do you consider has been most beneficial to the development of the automobile industry, of the three systems, which, in your judgment, do you class as No. 1?

Mr. MACAULEY. I can think of two, cross-licensing, and the one we use. What is the third?

Mr. PATTERSON. There are the Ford, the A. M. A., and the Packard.

Mr. MACAULEY. I think the Packard system is the most generally applicable, beyond any doubt. I don't think there are many industries to which the cross-licensing agreement of the A. M. A. would be applicable.

Mr. PATTERSON. That is the answer I want.

The CHAIRMAN. I don't think you understood his answer, or that Mr. Macauley understood your question. He thought you were referring to the application of this system to other industries in general. My understanding of your question was that you wanted to know which was the most beneficial to the—

Mr. PATTERSON (interposing). To the development of the motor industry.

The CHAIRMAN. The Ford system, the association system, or the Packard system.

Mr. PATTERSON. I think his reply will be the same.

Mr. MACAULEY. I would say the Ford system looks pretty good. He says he gives them for nothing to anybody that asks.

Mr. ARNOLD. Couldn't you say that the Ford system would be the best if you could afford it?

Mr. MACAULEY. I think it would be in Utopia; yes.

Dr. LUBIN. Mr. Macauley, I wonder whether you would be willing to venture an opinion as to why the manufacturers of motor vehicles prior to 1930 were willing throughout the A. M. A. to share not only existing patents but all new patents, excepting class B patents, whereas after 1930 they were unwilling to take a chance on sharing new patents that might be granted them with their competitors.

Mr. MACAULEY. Yes; I had the impression that they didn't have very many valuable patents prior to some date in there; I don't know what it was, and—

Senator KING (interposing). About 1925.

Mr. MACAULEY. After that, some of the companies began to expend huge sums of money and to develop more or less valuable things, and I think whenever they wanted to reserve the opportunity, whenever they were asked to go into an extension of their licensing agreement to look over what it was they were going to shovel into the general agreement and the value of it before they committed themselves.

It is a very human sort of position to take, I would say.

Senator KING. Do you think if that person in adopting a policy might take into account the fact that his company was expending perhaps several million dollars a year for new development, whereas other companies were expending very little, and, therefore, he would feel that he was entitled to some degree of discrimination or priority in the allocation of the patent?

Mr. MACAULEY. Very true.

The CHAIRMAN. Are there any other questions to be asked the witness? Mr. Cox, you have completed?

Mr. Cox. Yes; I have.

The CHAIRMAN. Gentlemen, you are excused with the thanks of the committee.

(The witness was excused.)

We will recess until tomorrow morning at 10:30.

(Whereupon at 4:30 p. m., a recess was taken until Tuesday, December 6, 1938, at 10:30 a. m.)

INVESTIGATION OF CONCENTRATION OF ECONOMIC POWER

TUESDAY, DECEMBER 6, 1938

UNITED STATES SENATE.
TEMPORARY NATIONAL ECONOMIC COMMITTEE,
Washington, D. C.

The committee met at 10:40 a. m., pursuant to adjournment on Monday, December 5, 1938, in the Old Caucus Room, Senate Office Building, Senator Joseph C. O'Mahoney presiding.

Present: Senators O'Mahoney (chairman), Borah, and King; Representatives Sumners and Reece; Messrs. Arnold, Henderson, and Patterson, Berge, and Peoples.

Present also: Department of Justice staff for Temporary National Economic Committee study—counsel, H. B. Cox (Special Assistant to the Attorney General), Joseph Borkin, Ernest Meyers, Charles L. Terrel, Benedict Cottone, Willis Rice, George Dession, Fowler Hamilton, H. C. Engelbrecht, Victor H. Kramer, J. M. Henderson, Monroe Karasik, Irving Glickfeld, Hyman Ritchin, David Clarke, Norman Bursler, and Seymour Lewis; also chief counsel for Federal Trade Commission Temporary National Economic Committee study, George W. Williams.

The CHAIRMAN. The meeting will please come to order.

Mr. Cox, are you ready to proceed?

Mr. Cox. I am, sir.

The CHAIRMAN. You may do so.

Mr. Cox. I have recalled Mr. Tibbetts, who testified yesterday afternoon with Mr. Macauley, because there is one matter I didn't cover that I wish to cover with Mr. Tibbetts.

The CHAIRMAN. Very well.

TESTIMONY OF MILTON TIBBETTS, VICE PRESIDENT AND PATENT COUNSEL, PACKARD MOTOR CAR CO., DETROIT, MICH.—Resumed

Mr. Cox. Mr. Tibbetts, how long have you been practicing at the patent bar?

Mr. TIBBETTS. Thirty-five years.

Mr. Cox. Is all of your time now devoted to the Packard Motor Car Co.?

Mr. TIBBETTS. Yes.

Mr. Cox. That has not been true all the time?

Mr. TIBBETTS. It has been for 31 years.

Mr. Cox. As a result of your experience at the patent bar, Mr. Tibbetts, are you prepared to venture an opinion as to any changes or corrections that might be made in the patent law so that it would more nearly fulfill the constitutional purposes?

Mr. TIBBETTS. During most of that time I have been on various committees of associations such as the National Association of Manufacturers and some committees in the Patent Office, and have consequently followed the various suggestions that have been made from time to time in connection with proposed legislation for changing

the patent laws, and I have formed some conclusions as to changes I think should be made, and amongst them, if you want me to state them—

Mr. Cox (interposing). I should like to have you do so.

Mr. TIBBETTS. In particular is the so-called 20-year proviso, which is a proviso fixing the term of the patent 20 years from the filing date or 17 years from the issue date, whichever is shorter. And with that, however—and I think this is probably one of the difficulties that has been encountered before in getting that provision through Congress—I think should go some other changes in connection with interferences. If you put that provision through only, you then make it bad for the applicant who is in the Patent Office and is tied up with interferences against his will, perhaps, and may be in there for 10 or 15 years and thereby have the term of his patent cut down considerably. If he had control of it that would be something else, but if the practice in the Patent Office itself, interferences and prosecutions, can be at the same time cut so that 3 years will be ample time for one to get his application out, then the 20-year proviso becomes a practical thing, so that in shortening interferences I might suggest that some of the appeals be cut out; that is, that the patent be issued, perhaps after a decision by the Examiner of Interferences, and that the Commissioner, for instance, be given authority to shorten the 6 months' period within which an applicant may comply with an official action. It is fixed at 6 months; it used to be 12 months some time ago. Let the Commissioner have the option of shortening that in cases where reply can be made very easily. That is true in a great many of the Office actions.

And perhaps a change in the public-use statute from 2 years to 1 year would bring applications into the office earlier, so that if a program of that sort is outlined, I think it would probably have a better chance at passage, and it certainly would be better than to try to pass any one of them.

The CHAIRMAN. Mr. Tibbetts, all of these suggestions which you have just made seem to be based upon a belief in your mind that the period of exclusive use to an inventor should be shortened.

Mr. TIBBETTS. No, Mr. Chairman, I don't think so. I think you should still have the 17 years, and that isn't any too long.

The CHAIRMAN. You misunderstand me. Of course, I realize that, but under the present practice, by reason of the provision which prevents the 17-year period from running until the patent is issued, the period of exclusive use is greatly lengthened, is it not?

Mr. TIBBETTS. Exclusive use starts only when the patent issues, sir.

The CHAIRMAN. When the patent is applied for, there can't be very much infringement without danger of litigation, can there, or am I mistaken about that?

Mr. TIBBETTS. If the infringement is continued after the patent issues, there will be infringements, but there can be none before that.

The CHAIRMAN. Perhaps I should state my understanding of your testimony this way: All of these suggestions which you have made impress me as implying the belief on your part that there should be a definite limit to the period of protection.

Mr. TIBBETTS. Yes, sir; and I don't think that the application should be kept in the Office as long; that is the main thing. Both of

these provisions will push them out earlier, the 20-year provision will throw them out earlier because one will not try to keep his application in the office for 5 or 6 years, as some have done.

The CHAIRMAN. The reason for limiting the period of exclusive use is, of course, the belief that any patent after a period should become public property. Is that right?

Mr. TIBBETTS. After the statutory period; yes, sir.

The CHAIRMAN. And you believe that is a very important phase of the method in which patents and inventions are handled, do you not?

Mr. TIBBETTS. I think it should have a definite period and it should not be prolonged by the prolongation of the work in the Patent Office.

The CHAIRMAN. All right, now in view of the fact that the Automobile Manufacturers Association has, with respect to some patents, followed the policy of free use, do you believe that the period of exclusive use generally should be shortened below 17 years?

Mr. TIBBETTS. I do not.

The CHAIRMAN. Why?

Mr. TIBBETTS. Because in so many cases I have seen that isn't long enough.

The CHAIRMAN. In other words, it is your belief that the inventor should have at least 17 years of exclusive use.

Mr. TIBBETTS. I do.

Mr. PATTERSON. Mr. Chairman, let me ask Mr. Tibbetts this, so that I can get it clear in my own mind. Do you mean that the period of termination of a monopoly should be fixed for the fixed number of years for the public benefit? Would you like to see it a fixed number of years?

Mr. TIBBETTS. It is a fixed number of years now, Mr. Patterson.

Mr. PATTERSON. I mean if the whole thing were changed.

Mr. TIBBETTS. The change I suggest is merely for the purpose of shortening the time in the Patent Office.

Mr. PATTERSON. Any other period of years than the 17—you wouldn't want to see a hundred years.

Mr. TIBBETTS. I certainly would not. I have forgotten just how the 17 years was arrived at, but it seems to be a very good compromise between the two cases, that is, one, the simple case where the monopoly is probably too long at 17 years, and the other where inventions are made and the art doesn't catch up with it until it is 10 or 12 years old, and then the 17 years is not long enough.

Senator KING. Your criticism of the patent system is the procedure rather than the constitutional provision, supplemented by the statute which gives to the patentee a monopoly for 17 years upon his patent.

Mr. TIBBETTS. The procedure as must be conducted by the Patent Office now. The Patent Office is doing a good job in getting the cases out.

Senator KING. Do you think that the Patent Office will have the right to shorten the period for interferences and limit the time within which the interference must be heard and determined?

Mr. TIBBETTS. Well, of course they have the limitations there now in time of taking testimony, and so forth. My thought is if you cut out several of the appeals, stop them at the examiner of interferences, that will save considerable time in the Patent Office.

Senator KING. Your idea would be to change the procedure in the Patent Office and make it simpler and more expeditious.

Mr. TIBBETTS. Yes, sir.

Senator KING. So that the time when the monopolistic provision of the patent should begin to run would be as soon as possible after the application for a patent has been filed.

Mr. TIBBETTS. Yes, sir.

Senator BORAH. I wish you would state a little more fully why you think it is proper just to have a 17-year period for some of these patent monopolies. That is a long time.

Mr. TIBBETTS. Merely from my general experience, that is all. It hasn't seemed long with a great many of the cases that we have had; others, it is too long, as I say, but you have to arrive at a compromise, of course. It might be 16, it might be 14, it might be 20.

Senator BORAH. I was rather anxious to get your views as a practical man as to why it seems just necessary to have it for so long a period in order to compensate the man who made the patent.

Mr. TIBBETTS. I could only answer that, Senator, by saying that with our cases we have never been overcompensated, I might put it that way, and we have had 17-year terms. I have seen a great many patents run out. I remember in the early days I thought 17 years was a long time, looking ahead; looking back, it is short.

Senator BORAH. Yes; I can imagine it would seem short in some instances. Well, I was simply trying to satisfy myself because I am in favor of a much shorter period, but I would like to have the viewpoint of those who know more about it and have had experience with it.

Mr. TIBBETTS. I think it would be a mistake, Senator, unless you go to the form of petty patents that they speak of, and that has been suggested, of course, for small patents, of a term of 3 or 5 years for the little things. I don't like that because that would just add to our numbers of patents; instead of two million we would have three or four million in a very short time.

Senator BORAH. You are speaking of the automobile industry entirely.

Mr. TIBBETTS. That is all I can speak for, sir.

The CHAIRMAN. You see, Mr. Tibbetts, the point that has impressed itself on me during the testimony is that in the automobile industry we had a system of handling patents, there is free exchange of certain patents which seems to be altogether at variance with the principle of the patent law, which is one of exclusive use. Now, the automobile manufacturers apparently felt that it was more important for them to have a free use of all of these patents among one another for the purpose of manufacturing than it was for each patent only, except in the case of Packard, of course, to charge royalties for the use of the patent. So you see there are two different policies with respect to the handling of patents.

Now, which is the better from the point of view of the public. That is the question which members of this committee are unquestionably asking themselves.

Is it better in the public interest that the monopoly upon the use of a patent should be shortened; that it should be maintained as it is or lengthened from the point of view of the inventor? Of course, it is desirable that he should have the exclusive use of that device for as long a period as he can so that he may charge the public for the use of it, but obviously those who drafted the patent

law now in existence believed that there should be a specific limit to that period, and that the public at the expiration of that period should have free use of the patent.

Now whether it be 17 years or 20 years or 5 years, that period is a grant from the public, from the people of the United States through their Government, to the inventor, and we are trying to find out what in your opinion would be a reasonable limit to that grant.

Mr. TIBBETTS. And my opinion is that we are just about right where we stand.

The CHAIRMAN. I see. Of course, you have been practicing under the 17-years law and it may be that tradition has something to do with that opinion.

Mr. TIBBETTS. It certainly has. We know nothing else in this country.

Senator KING. Isn't it possible if the procedure were modified so that the patent might be issued promptly after the application has been made, there would be no objection to a further limitation of the period of monopoly? If a person filed an application for patent and all of the rubbish and delays in the Patent Office might be cleared away and he would get his patent within 2 or 3 years definitely, then it would be far better if that might be done, to limit the time, say, to 10 years or 15 years.

Mr. TIBBETTS. I can't agree with you on that, because I think right now a very large proportion of patents—I should say 90 or 95 per cent—come out within 3 years. The Commissioner could answer that better than I.

Senator KING. A great number of them are held by interference for a long period of time.

Mr. TIBBETTS. I don't think the proportion is very great.

Senator KING. I think so, if you apply the rule to primary patents, patents of importance.

Mr. TIBBETTS. That may be. They are difficult to pick out.

Senator KING. With these small patents, perhaps the interference isn't very great, but I have made some investigation, and my investigation led me to believe that the evil was largely in the interference and in the delays of the Patent Office—not the fault of the employees, but the procedure which has been established and which seems to have been sanctioned by approval and by acts of Congress.

Mr. TIBBETTS. And those things could only be changed by statute. The Patent Office itself is doing everything it can.

Representative SUMNERS. I would like to ask Mr. Tibbetts a question, if it won't interfere with your course of examination. Mr. Tibbetts, of course, you were here yesterday and you know the general drift of the testimony that we have had thus far. It seems to me that the outstanding feature of the testimony yesterday was the exhibition of the automobile people as a group which was exchanging patents among themselves, exchanging the right to use their inventions among themselves.

Now, the question suggests itself to me as a member of the committee that if that is a good thing in practice, why shouldn't it be extended?

Mr. TIBBETTS. To other industries?

Representative SUMNERS. Yes; generally. And the queer thing about the business to me is that they have had this arrangement with

reference to some patents and do not have it with reference to others, and the ones that ought to have it seem to be established business people who don't want to have their business imperiled by somebody discovering something and putting them out of business. Those are the things that seem to be excluded. You can see how a bunch of businessmen who want to operate their business and sell to their customers and want to have some sort of business security, each one of whom was under the same peril of a revolutionary patent coming out that would put him out of business, might agree each with the other that they would avoid that by exchanging patents; but how it is when they use these minor patents by exchange and still expose themselves to that hazard, I don't understand; do you?

Mr. TIBBETTS. I don't believe I can explain that, Congressman. Of course, I am not in that group, as you know, as you have accepted me here. I am with the Packard Co. We believe they ought to pay for the patents if they use them, and we do ourselves if we do use them.

Representative SUMNERS. I thought this was an exhibition of how beautiful it was for brethren to dwell together in unity yesterday. I got it all mixed up.

Mr. TIBBETTS. Perhaps some of those witnesses following who are in the cross-licensing agreement can explain that better than I can.

Representative SUMNERS. What bothered me about it was that if it is a good thing, as seemed to be believed by some gentlemen yesterday who testified—and I don't say that in criticism, they probably gave us very valuable information—why wouldn't it be a very good policy generally when the Federal Government, as the chairman has indicated, as a matter of grace and not a matter of right, grants a patent, shouldn't there be attached to the patent the privilege of the general public, anybody, upon the payment of proper compensation, having the right to use it? But I am trying to find out, how it is inconsistent with the disposition of the Government to stimulate inventions and discoveries, to attach to that arrangement some provision which would prevent this grant on the part of the Federal Government from acting hurtfully to somebody engaged in a real productive business and serving the public interest?

I don't like to talk so much but I want to get this across. Why should the Government make an arrangement under which it will permit somebody to have the opportunity to destroy his competitors in business by reason of a basic discovery? I mean, as a matter of public policy, and as a matter of justice, why should the Government do it?

Mr. TIBBETTS. I don't know that it does do that, and I don't think I can answer your question, either.

Representative SUMNERS. You mean you think the hypothesis is not correct, that it isn't possible to develop a basic invention that might put competitors out of business? I have heard of its being done in some instances, but I don't know.

Mr. TIBBETTS. I may be wrong in my view of that, but my thought is that if this invention which you speak of is developed by one company, it isn't destroying anything when it keeps another company from using it. He has brought something else into existence.

Representative SUMNERS. Let's examine that a little bit. Suppose there is an invention that would revolutionize, greatly cheapen, increase the efficiency of, automobiles, for instance, and only one auto-

mobile company would use that invention, wouldn't its competitors be put at tremendously great competitive difficulty in trying to maintain themselves?

Mr. TIBBETTS. I suppose they would, but the other answer to that is that one of the other automobile companies would probably develop something just as good or better in the next few weeks or months, and as a result there would be competition.

Representative SUMNERS. I am not making these observations or asking the questions in an argumentative sense, but I appreciate that whether you all appreciate it or not, we are about to fundamentally examine the whole question of patents under our system. I think that is in the offing. I don't know whether it is in the offing or not; it may be right here now. So it is a proper time to make these basic inquiries, I think.

Mr. TIBBETTS. I think the answer to your question is this: The situation you refer to, I think, would in every instance take care of itself, in that if this thing that is invented and is controlled by one company is so absolutely necessary, it will be manufactured either by that company or, if it can't do it there, it will be licensed by someone. It has always taken care of itself, and I don't know why it won't in the future.

Representative SUMNERS. We heard yesterday that in regard to these patents that they knew about, they had entered into some agreement at least with reference to some of them. But with regard to some invention that might in the future develop, which would be revolutionary, they wouldn't grant their competitors a share in the possibility of use by any arrangement.

Mr. TIBBETTS. You are again in the cross-licensing agreement, of which I know very little except as an outsider. We don't do that. We weren't in the cross-licensing agreements, and I don't know how to differentiate their patents, because I don't know enough about them. I am sorry I can't answer your question, but I don't know how to.

Representative SUMNERS. I want to say to the gentlemen present, and I say this pretty personally, we are ignorant. I mean, seriously, we don't know these things that you gentlemen know, and we are going to have to legislate, and if we legislate without information it won't be the fault of our not trying to find out.

Mr. TIBBETTS. You understand I am not trying to evade your question. I just don't know and I am frank to state it.

Senator KING. Isn't it a fact that the patent system was not born when the republic came into existence, but that it existed in Great Britain and it existed in all of the States, and that they found, by experience, as was stated by George Washington in his first message to Congress, that it was wise to grant, for a limited period, the right to inventions and to writings. He emphasized writings, as a result of which our copyright time has been established and persons who write a good book like, if I may advertise it (and some who do not), "The Call of the Wild," would have a limited period within which they could exercise control over a patented invention or over the works of their brain, the writings which emanate from them.

Now, has not our development technologically and mechanically and in the arts as well as in what might be called the manufacturing business largely resulted from the patent system?

Mr. TIBBETTS. I think it has.

Senator KING. It has induced men to devote their lives to the discovery of new things that would promote in the end the general welfare.

Mr. TIBBETTS. That is why I think the substance of it should be left where it is.

Senator KING. In the early days before the patent system the people who had something good kept it a secret, and Parliament said, "If you give to the public the secret you have, we will give you a limited period within which you may have the full benefit of your secret. At the end of that time you must dedicate it to public use." So when a patent law was formed they accepted that view and fixed 17 years as the basis; and your complaint largely, as I understand it, is with regard to the procedural matters in the Patent Office under which the life is prolonged for a period which is, perhaps, I say, too long. I don't understand you to say that you object to A, B, C, and D, if they have patents and there is some question as to whether one is a slight infringement upon the other or whether it is a large infringement, giving a license, so to speak, to each other, mutual licenses, and then taking advantage of all of the inventions.

Mr. TIBBETTS. We are doing that right along.

Senator KING. You see no impropriety in that?

Mr. TIBBETTS. None whatever. It should be encouraged, to prevent litigation.

Senator BORAH. What they are doing is giving themselves the benefit of the shorter period. They are ending the period of 17 years between themselves the minute they interchange. I take it the Senator from Texas covered that question; but I want to repeat, these people have an opportunity to shorten the period from 17 years to a few months if they want to.

Mr. TIBBETTS. Between themselves.

Senator BORAH. Why isn't it a good idea to pass that around to the public?

Mr. TIBBETTS. As between themselves, each has got something from the other. They have exchanged. The public doesn't give anything if you hand it out to the public.

Senator BORAH. No; but the public is giving this man a special right to benefit from his patent.

Mr. TIBBETTS. The right to exclude others.

Senator BORAH. They are giving him a monopoly. Why should that monopoly be any extended length of time? It is something the public is giving to an individual.

Mr. TIBBETTS. In return for the individual giving to the public his invention.

Senator BORAH. He gets for a certain length of time the benefit of it. Why should it be 17 years? Seventeen years now would be a hundred years back when Washington lived.

Mr. TIBBETTS. I can't answer that. That 17 years seems to have worked out very well for a hundred years. Why change it?

Senator BORAH. It has worked out splendidly for some people.

Mr. PATTERSON. Yesterday there was some testimony tending to condemn the grant of patents on alleged trivial inventions.¹ From

¹ Supra, pp. 280, 282.

your experience as a manufacturer and a patent lawyer, do you care to express any kind of opinion as to the difficulties of attempting to classify an invention as trivial on the one hand, and as important on the other?

Mr. TIBBETTS. That isn't easy to answer, Mr. Patterson. I think it is very difficult to classify them that way. Some countries have attempted to do it by issuing petty patents of 5 years, I think, and another patent on real inventions for longer terms. I have always been against it. I don't think you can do that, because you never know what may be a petty patent today may be of a great deal of importance tomorrow. I am thinking of one instance of our own, where we developed a heater for the engine fuel. To shorten the name of it I call it the "fuelizer," because that is what we called it, and we used it on the car for several years.

Later carburetors developed and fuel developed so we didn't need it and it was dropped. We had probably 50 or 75 patents on various forms of that fuelizer, some of which we bought, some of which we took out ourselves, but as soon as we dropped it those patents were of no value at all so far as we could see.

But 2 years ago a manufacturer came out with an accessory for an automobile, a heater for the body of the automobile, which involved the same principles and the same construction, and came to us and asked for a license.

Well, that series of patents is now netting us twenty or thirty thousand dollars a year in royalties. Two years ago those were petty patents, or useless, practically. Today they are of considerable value to us.

That is about the best illustration I have of why you can't tell.

The CHAIRMAN. That is an illustration of an instance in which your inventor developed an idea for a particular purpose. He used the patent for that purpose, abandoned the patent, and then another inventor conceived the idea of using a similar device for an altogether different purpose and had to pay you a royalty.

Mr. TIBBETTS. Yes; so we may get some of our money back in developing it in the first instance.

The CHAIRMAN. It may be beneficial to you, but was it to him?

Mr. TIBBETTS. Why not? He has an exclusive license and will be able to control to some extent the competition there, which you should have the right to do. He will have patents on his adaptation of it.

Representative SUMNERS. I would like to ask one question which I do not think has been made clear, and that is this: Is there a good reason why, upon the payment of a proper compensation, anybody ought not to be privileged to use in his business a novel invention?

Mr. TIBBETTS. The best answer I would have to that is that with small companies, particularly where they rely entirely upon their patents and their exclusive use for the development of that company, if they had to license someone else they just would be out of business; that's all.

Mr. OLIPHANT. Are you talking about existing or future patents? I understood the Congressman was referring to future patents.

Representative SUMNERS. I wanted to know generally, and I got your answer, and I appreciate it.

Mr. TIBBETTS. I don't know that it makes any difference. A small company, probably organized because of the patented invention, if it

had to immediately, before it got its money back at all (and maybe it cost many hundreds of thousands or a million dollars to go into the business) might give it to a competitor for nothing—

Representative SUMNERS ((interposing). I got your answer. I would like to pursue it further. Does this right to have a patent add to the possibility of a new concern getting in the business as distinguished from the situation, if you can imagine it, where no patents were granted?

Mr. TIBBETTS. I wonder if I understand your question?

Representative SUMNERS. I did it pretty well that time. Will the reporter please read the question?

(The reporter read the previous question.)

Mr. TIBBETTS. That is a difficult question to answer. I can answer it only in this way.

Representative SUMNERS. People don't have any patents on curing sick folks, though some doctors do it better than others, you know, and things of that sort.

Mr. TIBBETTS. With no patents at all the company would have to get in production in a secret way, keep his patent secret as long as he could.

Representative SUMNERS. He wouldn't have any patents.

Mr. TIBBETTS. He would have to keep his inventions secret so long as he could, and then, as soon as it came out, he would have the difficulty of having competition immediately, I suppose, unless it was one of those things that required a great deal of capital to get into the business. Certainly the incentive is there if he has a patent. If he has no patent, I should think the incentive would be gone, to a certain extent.

Mr. ARNOLD. The difficulties he would get into would be difficulties of competition.

Mr. TIBBETTS. Decidedly so.

The CHAIRMAN. Mr. Patterson, I am sorry for having interrupted your question. You may have the floor now until you have finished your questions.

Mr. PATTERSON. Mr. Tibbetts, will you kindly express your opinion on this question: In connection with the demand for fewer and better patents that came out in the testimony yesterday,¹ do you think this is possible by making the Patent Office a tribunal of last resort; or, in other words, without abolishing appeals from the Patent Office to the courts?

Mr. TIBBETTS. I don't see how you can do that unless you can define patentable inventions and force the courts to follow such definitions, and that seems to be an impossible thing to do, because the Commissioner is guided entirely by the courts to which appeals are taken from his decisions. At the present time, if he raises the standard of invention in the Patent Office, the rejected applicant immediately goes to the Court of Customs and Patent Appeals or under 4915 to the district court and has him overruled.

Mr. PATTERSON. Let me ask this: Do you believe in fewer and better patents?

Mr. TIBBETTS. I do, if we could get them, but I don't know how to get them.

Mr. PATTERSON. Strike that out.

¹ Supra, p. 282.

Senator KING. You wouldn't be in favor, would you, of making administrative bodies the last resort, and deny to the inventors the processes of review in judicial court?

Mr. TIBBETTS. No, Senator; but I think we could make the Patent Office give an administrative award and issue a patent and then still have it so the other party to an interference can go out and obtain his patent also, and in that way, if you can prove earlier production than the other one you will have a patent that will take precedence over the first issue.

Senator KING. You would not be in favor of permitting some organization in the Patent Office, even the head of the Patent Office, to determine that A or B is entitled to a patent and make his determination absolutely final, denying the right of appeal through the court; in other words, cutting off judicial review and making the administrative officer the court of last resort?

Mr. TIBBETTS. I am not in favor of that; but I think the patent could be issued and the question be decided on appeal later.

Senator KING. Or after the patent was issued, if an attempt was made to sue for infringement, then the whole question would be brought to the court as to the validity of the patent?

Mr. TIBBETTS. Yes, sir; and it should.

Senator KING. But at any rate, the court, if the matter was brought to its attention, would have the final say in determining the validity of the patent or whether there was an infringement.

Mr. TIBBETTS. We must have that.

The CHAIRMAN. Mr. Cox, have you concluded? Would it interrupt you if Dr. Lubin were to ask a question?

Mr. Cox. No, sir.

Dr. LUBIN. Mr. Tibbetts, to your knowledge has the Packard Motor Co. ever refused to grant a license to one of its competitors on a patent it was using in the production of its motorcars?

Mr. TIBBETTS. Not to my knowledge. I think Mr. Macauley answered that question yesterday in the same way. I have known of every license we have granted in the last 30 years.

Mr. Cox. That raises a question in my mind which has puzzled me a little, Mr. Tibbetts. Mr. Macauley and you both have testified that the Packard Co. believes if someone wants to use one of your patents, he should pay a royalty; nevertheless Mr. Macauley testified yesterday that even though people used your patents without paying a royalty, you never sued them.¹ If you believe in collecting royalties on your patents, why don't you pursue a more aggressive litigation policy?

Mr. TIBBETTS. I thought Mr. Macauley qualified that. I suggested to him that he do so, and I thought it got into the record that we hadn't found it necessary to bring suit, but we certainly would not say we would never bring suit under our patents, because we have contemplated it a good many times, but it just simply became unnecessary, because we either issued a license or it was settled in some way.

The CHAIRMAN. You succeeded in protecting yourself without litigation?

Mr. TIBBETTS. Exactly.

¹ See *supra*, p. 307.

Mr. Cox. Would you say, Mr. Tibbetts, that the expense of patent litigation is one of the blemishes of the present patent law?

Mr. TIBBETTS. I can't answer that question, simply because the Packard Co. has been able to keep out of litigation, both aggressively and defensively. We have had but four suits filed against us, and all have been settled or abandoned, so our litigation expense has been nil.

Mr. Cox. Do you have any opinion at all as to whether any steps might be taken which would reduce the expense of patent litigation?

Mr. TIBBETTS. I don't say that I have. I am not qualified to speak on that.

Mr. Cox. Reverting for a moment to the term of the patent, it is true, isn't it, that in the early days of the Republic the term was for 14 years? Do you recall?

Mr. TIBBETTS. I think it was.

Mr. Cox. The only point I wish to make, and I wanted to see whether you agree with me, is whether the 17-year period isn't merely a historical accident. It is not a reasoned choice, is it?

Mr. TIBBETTS. I don't know, but I thought it was a compromise somewhere between the English law, 14 years, which they had then—16 now—and a 20-year period somewhere else. I confess I am a little lax in history there.

Mr. PATTERSON. I may be able to help there. My colleague the Commissioner of Patents has just told me that when they had the 14-year period there was a provision to renew. With the 17-year period there is not.

Mr. TIBBETTS. I have forgotten.

Mr. Cox. Of course the 14-year period was carried over from the English law.

Mr. TIBBETTS. That is my understanding.

Mr. Cox. We understand that that period probably developed out of the English practice of granting a patent on a particular occupation which would last for two periods of apprenticeship, 7 years each. Is that your understanding?

Mr. TIBBETTS. That is my understanding, now that you recall it to my mind.

Representative REECE. I shall first say that your response to Senator Borah's question that it had worked well for a hundred years, therefore should not be altered may be all right, but it seems to me that conditions have changed a great deal with reference to the utilization of patents and the effect of the introduction of a new patent might have upon more than one industry, or possibly industry generally. A hundred years ago an important patent might have been developed. It would have required at that time an organization of a new business, which would have been the beginning of a new industry in order to utilize that patent.

Industry today is so widely developed in all of its phases so that it is difficult to conceive how a new patent might now be developed which could not be utilized by some business or industry that is now in operation, and conversely, it is difficult to conceive how such an important patent could be devised which would not have a more important effect upon industry if other concerns are not able also to take advantage of that patent. That is, as one of the members a while ago indicated in his question, it might destroy business which

is already developed in connection with which a great deal of capital has been invested. It would seem to me that those are questions which rise for consideration which might not have obtained a hundred years ago, or when our present patent laws were placed upon the books.

What is your thought in that connection, if I may ask?

Mr. TIBBETTS. I would say that we are having that every day as a matter of fact; a company comes out with something new and it makes obsolete something that some other company is making or something that that particular company was making itself, so far as that is concerned, and I was going to say why shouldn't that company have the advantage of a few years use of that particular improvement over its competitors. The competitor will come out with something just as good or better.

Representative REECE. I agree with you this far, and I am not saying that I disagree in any respect, but I readily recognize that he might have certain advantages, but if granting those advantages should destroy the investments of other people, he then is getting more than an advantage, starting a destruction of investments which would seem to me to give rise to a different question if such a condition should arise.

Mr. TIBBETTS. You have stated an answer as well as a question, you might say. I don't know how I could improve upon it.

Representative REECE. It was an observation, I will say.

The CHAIRMAN. May I interrupt at this point? I think in the interest of expediting the proceeding, it will be a better policy if we permit Mr. Cox to complete his examination in chief before there are any more interruptions.

Mr. Oliphant says he would like to ask a question in this connection.

Mr. OLIPHANT. I should like to ask if he considers that the disruption of industry, of investments, dislocation of employment by sudden emergence of new patent processes is in contemporary society a trivial matter.

Mr. TIBBETTS. Taking the question as you put it, I would say, no; it is a very important matter.

Mr. OLIPHANT. It is a serious matter.

Mr. TIBBETTS. I would think so.

Mr. Cox. Mr. Tibbetts, yesterday Mr. Macauley said that the Packard Co. was frequently threatened with infringement suits by persons holding patents.¹ Have you ever examined any of those instances to determine how many of the threats were made with respect to a paper patent; that is, a patent that had never in fact been put into practical operation?

Mr. TIBBETTS. I don't know the relative proportion, but most of them are, you might say.

Mr. Cox. It is a fact, then, that in at least your experience paper patents are used for purposes of threats and litigation?

Mr. TIBBETTS. Not entirely so. Paper patents have their use. As a matter of fact, many inventions start from paper patents and are followed by the practical application of the invention. It comes on later and other patents are granted on the improvements.

¹ *Supra*, p. 308.

Mr. Cox. In other words, then, you think it is difficult to draw a distinction between a patent which is merely a claim on paper and a patent which has actually been put into practical operation?

Mr. TIBBETTS. A paper patent may be a paper patent today and may be a very practical and important one tomorrow when somebody begins to manufacture on it.

Mr. Cox. The point that I am trying to inquire into is whether any distinction should be made with respect to a man who holds a patent which he has never attempted or tried to put into practical operation, either by licensing someone to manufacture or by attempting to manufacture himself, and a patent which has actually been used in one of those ways.

Mr. TIBBETTS. I think probably the courts make some distinction in their determination of validity of such patents, but I don't know whether we could do it in a practical way or not.

Mr. Cox. You think the distinctions the courts make in that respect are adequate to take care of it?

Mr. TIBBETTS. I would think so.

Mr. Cox. I think I have finished.

The CHAIRMAN. You have finished with your examination of this witness?

Mr. Cox. Yes.

The CHAIRMAN. If so, Mr. Tibbetts stands excused, and we are very much indebted to you, sir.

(The witness was excused.)

The CHAIRMAN. Will you call the next witness, Mr. Cox, please?

Mr. Cox. Mr. Knudsen.

The CHAIRMAN. Mr. Knudsen, do you solemnly swear that the testimony you are about to give in this proceeding will be the truth, the whole truth, and nothing but the truth, so help you God?

Mr. KNUDSEN. I do.

Mr. Cox. Perhaps we might swear Mr. McEvoy at the same time.

The CHAIRMAN. Mr. McEvoy, do you solemnly swear that the testimony you are about to give in this proceeding will be the truth, the whole truth, and nothing but the truth, so help you God?

Mr. McEvoy. I do.

TESTIMONY OF WILLIAM S. KNUDSEN, PRESIDENT, GENERAL MOTORS CORPORATION, DETROIT, MICH., AND JAMES McEVROY, DIRECTOR OF PATENT SECTION, GENERAL MOTORS CORPORATION, DETROIT, MICH.

The CHAIRMAN. Mr. Cox, may I interrupt the examination long enough now to renew the suggestion which I made at the conclusion of the recent examination. If the members of the committee will permit Mr. Cox to complete his examination before interrupting with questions, I think that we will expedite the hearing very materially and unless there is objection, that will be the rule.

Mr. Cox, you may proceed.

Mr. Cox. Mr. Knudsen, will you give the reporter your name and address?

Mr. KNUDSEN. William S. Knudsen, president of General Motors Corporation, Detroit, Mich.

Mr. Cox. Mr. McEvoy, will you do the same thing?

Mr. McEvoy. James McEvoy, 1771 Burns Avenue, Detroit, Mich. I am director of the patent section, General Motors Corporation.

Mr. Cox. Will you tell us again what your present position with the company is, Mr. Knudsen?

Mr. KNUDSEN. I am the president.

Mr. Cox. How long have you been connected with General Motors?

Mr. KNUDSEN. Seventeen years.

Mr. Cox. What was your first work with the company that you started out with?

Mr. KNUDSEN. I was operating vice president of the Chevrolet Motor Co.

Mr. Cox. How long have you been connected with the motorcar industry?

Mr. KNUDSEN. Referring to cars and parts, both?

Mr. Cox. Yes.

Mr. KNUDSEN. Thirty-one years.

Mr. Cox. In what capacity did you first work in the motorcar industry?

Mr. KNUDSEN. I worked as a foreman.

Mr. Cox. What position in the General Motors Co. did you hold before you became president?

Mr. KNUDSEN. I was operating vice president of Chevrolet, and then from 1922 to 1924 I was made general manager and president of the Chevrolet Motor Co., which position I held until 1933, October. I was then made operating vice president of the corporation from October 1933 until May 1937, when I was made president.

Mr. Cox. As a result of your experience, Mr. Knudsen, are you familiar with the policy which the General Motors Co. followed with respect to patents?

Mr. KNUDSEN. Yes, sir.

Mr. Cox. Mr. Knudsen, would you say that the motorcar industry is a highly competitive industry?

Mr. KNUDSEN. I think we will admit that.

Senator BORAH. How is that?

Mr. KNUDSEN. I think we will all admit that.

Mr. Cox. Each company, in your opinion, is trying to make the best car it can and sell it to the public at the lowest price possible.

Mr. KNUDSEN. Yes, sir.

Mr. Cox. And that is true of General Motors, certainly, you would say?

Mr. KNUDSEN. Yes, sir.

Mr. Cox. What competitive use does General Motors make of its patents? I will withdraw that question.

Mr. KNUDSEN. I put something down here. Maybe I can answer it.

Mr. Cox. I will withdraw that question, and we will take it up a step at a time. Does the General Motors Co. apply for and take out patents on inventions?

Mr. KNUDSEN. Yes, sir.

Mr. Cox. For what purpose does it take out patents?

Mr. KNUDSEN. To use in the manufacture of motorcars and parts.

Mr. Cox. You use the device that the patent covers, isn't that correct?

Mr. KNUDSEN. I don't know that we have used all of them; we might have found a better one **after** we proceeded.

Mr. Cox. What I am trying to inquire into is why you take out the patent itself, why don't you just use the invention that you make without taking out the patent?

Mr. KNUDSEN. Sometimes we have to take out patents for protective purposes.

Mr. Cox. That is, you take it out so someone won't sue you for infringing, who develops the same idea later on?

Mr. KNUDSEN. Yes, sir.

Mr. Cox. You use those patents to collect royalties from others?

Mr. KNUDSEN. To some extent, yes.

Mr. Cox. Does that represent any very considerable part of your company's income?

Mr. KNUDSEN. We pay about four times more than we take in.

Mr. Cox. You take licenses from others as well as grant licenses to others under your own invention?

Mr. KNUDSEN. Yes, sir.

Mr. Cox. Do you ever use those patents, your own patents, in an attempt to get a competitive advantage in the industry?

Mr. KNUDSEN. I don't understand your question.

Mr. Cox. I will withdraw that question and ask another one. Did you ever refuse to grant licenses under your patents to your competitors in the industry?

Mr. KNUDSEN. Have we?

Mr. McEvoy. No; never.

Mr. KNUDSEN. Never have. I don't know of any.

Mr. Cox. Suppose the patent system should be abolished tomorrow, Mr. Knudsen, do you have any opinion as to what difference that would make to the competitive position of General Motors in the automobile industry?

Mr. KNUDSEN. No; but I think it would be bad for industry generally.

Mr. Cox. You think it would be bad for industry generally?

Mr. KNUDSEN. Yes; I think so.

Mr. Cox. You think that it would be detrimental to the inventor.

Mr. KNUDSEN. Yes, sir.

Mr. Cox. By the way, are you an inventor, Mr. Knudsen? Have you ever invented anything?

Mr. KNUDSEN. I have two patents filed, assigned to the people I was working for; that is all. I am no inventor.

Mr. Cox. In making those inventions, were you stimulated by the thought that you or someone was going to get a patent on them?

Mr. KNUDSEN. No; I wanted to get out more work.

Mr. Cox. You wanted to produce more cars.

Mr. KNUDSEN. Yes, sir.

Mr. Cox. The patent didn't make much difference to you. Is that right?

Mr. KNUDSEN. No.

Mr. Cox. I want to make sure you mean it did make a difference or didn't.

Mr. KNUDSEN. It did not make a difference. I might explain it this way, that I thought the patent, so-called, was rather insignificant. I turned it over to the people I was working for. I had no idea of getting anything in particular out of it.

Mr. Cox. While you have been connected with General Motors and being responsible in any way for its policy, has the company ever considered adopting Mr. Ford's policy of granting licenses royalty free?

Mr. KNUDSEN. I don't know; we talked about it.

Mr. Cox. What do you think about that policy?

Mr. KNUDSEN. Well, it is sort of tied up with your first question when you asked me whether we should abolish patents. It sort of ties up with that, and you say as soon as you get a patent you should grant a license. Does that mean you should only do that if you were big and not if you were small?

Mr. Cox. Well, I will ask the question generally as to both big and small units.

Mr. KNUDSEN. Then you would be right back to your previous question where you said abolish them altogether, because that would be the same thing.

Mr. Cox. Do you think that would be bad for the individual inventor?

Mr. KNUDSEN. Yes; I think it would be bad for progress.

Mr. Cox. It seems to you that what the Ford licensing policy does, in effect, then, is just to abolish the patent system. Is that right?

Mr. KNUDSEN. Well, it all depends on what Mr. Ford requires. If he doesn't require any, then he doesn't have to bother about it. In his particular job today, it might be that patents wouldn't interest him; I don't know.

Mr. Cox. You think a system under which patents were used in the way in which Mr. Ford uses his patents, that is, in granting licenses, royalty free to everyone, would be a system under which the patent as such would not be of any particular importance, is that right?

Mr. KNUDSEN. I don't know as I could answer that. He might grant a license, a good one; I don't know.

Mr. Cox. You don't think that policy is a good thing for industry generally?

Mr. KNUDSEN. It all depends on what you manufacture. If Mr. Ford today is willing to grant licenses on automobile patents, perhaps that is fine from his standpoint, but to say that we as a corporation could do the same thing without taking the interest of the stockholders into consideration, why, I think it would be wrong.

Mr. Cox. Mr. Knudsen, can you tell us whether the General Motors Co. follows the practice of suing persons who use patents without obtaining a license?

Mr. KNUDSEN. No; we always try to avoid it. We don't want any suits.

Mr. Cox. Can you tell us, or can Mr. McEvoy tell us, how many patent suits the company has been plaintiff in?

Mr. McEvoy. Yes, sir.

Mr. KNUDSEN. You are referring to automobiles only?

Mr. Cox. At the moment; yes.

Mr. McEvoy. You mean just the automobiles?

Mr. Cox. And parts.

Mr. McEvoy. We have had 25 suits altogether since the beginning of the corporation. That related to everything.

Senator BORAH. How old is the corporation? When was it incorporated?

Mr. McEvoy. In 1912.

Mr. Cox. Perhaps we can get to these figures later on in the examination.

Mr. McEvoy. I have them picked out here.

Mr. KNUDSEN. We have many articles other than automobiles.

Mr. Cox. Why is it, Mr. Knudsen, if you are interested in collecting royalties under your patents, that you don't go after people who use them without getting a license from you?

Mr. KNUDSEN. The reason for it is this: They generally apply to things we make and sell to the trade. Consequently, we would rather sell people goods than collect royalties, so generally we are able to make an honest arrangement whereby we sell at a fair price the article, which includes the patent. You see, we have a good many parts companies that make all sorts of different things, and we sell to the trade. We even sell to Mr. Ford.

Mr. Cox. Would it be right then to say that so far as your competitive position is concerned, you rely more on your efficiency as a manufacturing concern than you do on any monopoly position you get by reason of a patent?

Mr. KNUDSEN. I hope that will always be correct, sir.

Mr. Cox. That is correct, indeed.

General Motors carries on a large amount of research work, doesn't it?

Mr. KNUDSEN. Yes, sir.

Mr. Cox. And that is a separate department?

Mr. KNUDSEN. Yes, sir. Well, we have a central research department but the individual laboratories carry out their own.

Mr. Cox. Is that work expensive?

Mr. KNUDSEN. Yes. Mr. Kettering is here and he could tell you, but my recollection is that it costs about \$1,200,000 a year.

Mr. Cox. The question I am coming to, Mr. Knudsen, is this: Suppose that General Motors was unable to take out patents on any inventions it made, would it still continue to spend that money for development and research work?

Mr. KNUDSEN. Yes; I am sure we would.

Mr. Cox. You think it would make no difference?

Mr. KNUDSEN. I don't think it would make any difference.

Mr. Cox. Do you have any opinion whether in the case of research and development work that is carried on by smaller organizations or by an individual, the absence of a patent would make any difference?

Mr. KNUDSEN. I think a small man or small fellow, a small mechanic, wouldn't be able to get as far as he can today, because with a patent in his hand he can at least offer to industry and have them judge as to its value.

Mr. Cox. Your company is now, and has been for a number of years, a member of the Automobile Manufacturers Association; is that right

Mr. KNUDSEN. Yes, sir.

Mr. COX. Are you familiar generally with the nature of the cross-licensing agreement that is administered by the association? ¹

Mr. KNUDSEN. I know it in a general way, but if you want any details I suggest you ask Mr. McEvoy, because I naturally didn't study that part.

Mr. COX. Do you have any opinions as to whether or not that cross-licensing agreement has been a good thing?

Mr. KNUDSEN. I think in the early days of the industry when it was being developed, it was. I might explain that perhaps best in this way. There are three stages in the development of an article. The first is the inventive stage, that is the idea; the second is the development stage, that is when the device is being perfected for production; and the third is the mass production stage. Now anyone who invents anything has got to pass those stages before it becomes really profitable, and the first stage he can probably do himself, the second he can partly do himself; with the third he might have to engage capital to carry it through, and that is the way he makes the real money.

Mr. COX. Reverting again to the cross-licensing agreement, at what stage in the development of the motorcar industry do you think that agreement was most beneficial?

Mr. KNUDSEN. Everybody was in the development stage at that time.

Mr. COX. And that was the time when you think it was most useful?

Mr. KNUDSEN. Yes, sir.

Mr. COX. Do you have any opinion as to whether a similar arrangement should be extended to other industries in the development period?

Mr. KNUDSEN. I don't know what the condition is.

Mr. COX. You think that the answer to that question might vary from industry to industry; is that it?

Mr. KNUDSEN. It depends first on the public demand for the article; and if you will tell me specifically what you refer to, I might give you an opinion. Otherwise, I prefer not to.

Mr. COX. Do you think after the development stage was passed in the motorcar industry that the cross-licensing agreement was not of such importance as it had been before?

Mr. KNUDSEN. Well, the progress from then on would have to be in specific things. The car would run, the car was made, but from then on the progress would have to be specific. For instance, someone would have to develop a new sort of motor, a new sort of axle, a new sort of transmission, entirely different from what we were working on. I think it would be fair to hold that out so as to get it through the development stage before it was given to the public.

Mr. COX. But the cross-licensing agreement, in your opinion, was chiefly useful in the period when the basic ideas in the art were being developed.

Mr. KNUDSEN. Everybody was handling the thing.

Mr. COX. Do you recall that a change was made in that cross-licensing agreement in 1925 so as to exclude from its operation the

¹ Supra, p. 286 et seq.

patents which were acquired thereafter by the members?¹ Do you recollect that?

Mr. KNUDSEN. That is not correct, I think, is it? It was restricted to patents granted before January 1, 1930, I believe.

Mr. McEvoy. He is talking about the first extension.

Mr. Cox. The first extension, that is right. It froze the patents in the cross-licensing agreement as of January 1, 1925; is that correct?

Mr. McEvoy. No, it limited the patents to those which might have emanated from or were produced by a plant making a complete automobile, a complete motorcar. It eliminated accessory patents and things of that sort.

Mr. Cox. I am talking about the time limit. Wasn't it in 1925—patents thereafter acquired? I think Mr. Reeves touched on that effect yesterday.¹

Mr. McEvoy. I think I will read that to you. I see what you mean, that the agreement was for 5 years and expired December 31, I think, 1929, but all the patents that might belong to the members falling within the class provided in the agreement down to December 1929 came within the terms of it.

Mr. Cox. Down to the 1st of January 1925—

Mr. McEvoy (interposing). The first agreement expired then.

Mr. Cox. And the renewal made at that time applied to all patents except certain exceptions which were owned by the members as of January 1, 1925, and ran until 1930?

Mr. McEvoy. That is right.

Mr. Cox. Could you understand that, Mr. Knudsen?

Mr. KNUDSEN. Yes, sir.

Mr. Cox. Do you recall whether at the time that change was made, General Motors was in favor of the change?

Mr. KNUDSEN. I don't recall. I wasn't in the directing chair at that time.

Mr. Cox. Do you recall anything about the change that was made, a renewal that was made in 1930 of the cross-licensing agreement?

Mr. KNUDSEN. No, sir.

Mr. Cox. Or one in 1935?

Mr. KNUDSEN. No.

Mr. Cox. You have no recollection of those?

Mr. KNUDSEN. I wasn't president at the time.

Mr. Cox. Taking it on the basis of your experience in the motorcar industry, Mr. Knudsen, do you think that the patent system as it is worked in that industry has promoted science and the useful arts?

Mr. KNUDSEN. Yes; I think through the extended life of the motorcar, patents have helped to develop the motorcar.

Mr. Cox. Do you think that the use of patents today is an important competitive practice in the motorcar industry?

Mr. KNUDSEN. No, I don't; but I think it is an incentive, it is a thought, and a driving force to work toward final betterment.

Mr. Cox. To whom, in your opinion, is that incentive directed; the large companies or the people outside large companies?

Mr. KNUDSEN. I think anyone has a chance, if he has a real good article.

¹ See supra, p. 290.

Mr. Cox. To get a patent which will reward him financially?

Mr. KNUDSEN. Yes, sir.

Mr. Cox. Of course, as far as your company is concerned, you would continue to do research and development work whether you could get patents or not; is that right?

Mr. KNUDSEN. Yes; we would have to do that to protect our investment and our employment.

Mr. Cox. Has your company been sued many times for patent infringement?

Mr. KNUDSEN. Yes; quite often. We have at present a suit pending.

Mr. McEvoy. We have had 99 suits all together brought against the corporation since its inception.

Mr. Cox. Have you found that litigation which arises under patents has been a burdensome thing financially?

Mr. KNUDSEN. No, sir.

Mr. Cox. You haven't had to spend much money?

Mr. KNUDSEN. We have paid out, that is in the cost of suits—

Mr. McEvoy (interposing). What was the question?

Mr. KNUDSEN. Whether the patent suits have been burdensome to us financially.

Mr. McEvoy. Here is a tabulation of what it has cost us since 1924.

Mr. KNUDSEN. Our total expenditure along the lines you suggest has been \$2,526,010 since 1924.

Mr. Cox. Mr. Knudsen, we have had three general kinds of patent practices described here: the practice which is followed by Mr. Ford of granting licenses to everyone free;¹ the practice which has been followed by your own company and the other members of the Automobile Manufacturers Association of cross-licensing patents;² and the policy which has been followed by the Packard Motor Car Company of retaining its own patents, not entering into any cross-licensing agreement but licensing others for a royalty.³ Do you have those three in mind? Do you understand what I mean by the three practices?

Mr. KNUDSEN. Yes; I do.

Mr. Cox. Do you have any opinions as to which of the three practices is more beneficial to the industry and to the public generally?

Mr. KNUDSEN. No; I think it is a matter for the manufacturer himself to decide what he can do in justice to his stockholders, or how patents may affect his particular job. As far as I am concerned, I listened of course to what was said this morning, and the outstanding thing was that some gentleman thought that a man making a revolutionary invention in the automobile business could take all the business. It can't be done.

Mr. Cox. Why can't that be done?

Mr. KNUDSEN. Because you can't make it.

Mr. Cox. You think the art has reached such a point that that kind of invention isn't possible?

Mr. KNUDSEN. It is quite possible; but if it was produced nobody would take it in the automobile business. There is too much of it

¹ See supra, pp. 256-285.

² See supra, pp. 285-303.

³ See supra, pp. 304-313.

there and the public wouldn't stand for it. If it was controlled by one man everybody would get sore.

In trying to quote what you say and put it in another sort of words, I think we have followed the policy of either selling the patents to other manufacturers or licensing them at an extremely low cost. That is the point, I guess, that you brought up.

Mr. Cox. Yes.

Representative SUMNERS. Mr. Cox, there was no suggestion by any question that I know of, of "at an extremely low price." I am not interrupting the witness. The question was based upon the assumption that there would be a reasonable remuneration for the right to use.

Mr. Cox. That is right, as I understood. I am going to inquire about that.

Representative SUMNERS. I thought I would save a little time by making that statement.

Mr. Cox. With respect to the licenses you grant under your patents, on what basis are the royalty fees fixed in those licenses determined?

Mr. KNUDSEN. They generally have relationship to the cost of the article—a small percent. We could never make any money on it.

Mr. Cox. You don't make money on it?

Mr. KNUDSEN. We couldn't.

Mr. Cox. Why do you bother to charge them, then?

Mr. KNUDSEN. In order that we might induce them, perhaps, to buy some of our stuff in which the device is used.

Mr. Cox. Is that because if you manufacture it yourself and pay, naturally, no royalty to yourself, you are able to manufacture and sell it more cheaply than one can who must pay a royalty under the license?

Mr. KNUDSEN. Yes; and I think the cost of the development, of research, should be recovered in that way.

Mr. Cox. That is another thing I am interested in. To what extent, in determining your fees under these license agreements, do you take into account the amount of money which you have spent in research and development in perfecting the patent?

Mr. KNUDSEN. I can't remember any case. Maybe Mr. McEvoy can bring that out. Are you able to answer it?

Mr. McEvoy. No.

Mr. Cox. Is that a factor you consider at all?

Mr. KNUDSEN. It is very seldom we hear of that.

Mr. Cox. In other words, you simply fix the royalty fee under the license agreement on the basis of some percentage of the cost of the patented article produced?

Mr. KNUDSEN. Yes; a very low percentage. We don't want to affect the price to the public.

Mr. Cox. Even if it is to be manufactured by your licensee you don't want to affect the price to the public?

Mr. KNUDSEN. No, sir.

Mr. Cox. Do you grant licenses to your licensees all on more or less the same terms with respect to the same article? Do you understand that? I mean, if you have one article and are granting licenses to different persons—

Mr. McEvoy (interposing). Always uniform.

Mr. KNUDSEN. It would always be uniform.

Mr. Cox. Is it the practice of the company to grant many exclusive licenses to other companies?

Mr. KNUDSEN. I don't think we have any.

Mr. McEvoy. That is right.

Mr. Cox. Is it the practice of the company to put any restrictive conditions of any kind in the license agreements that you grant?

Mr. KNUDSEN. No, sir.

Mr. Cox. Do you ever restrict the use of patented articles to the automotive field as distinguished from the aircraft?

Mr. McEvoy. We have done that in one or two cases.

Mr. Cox. There is no restriction on the quantity of the article to be produced or the price at which it may be sold.

Later we hope to recall Mr. McEvoy for a little more detailed testimony with respect to the experience of the company under the patent system, and particularly with respect to any suggestions Mr. McEvoy may have as to changes in the patent law, but before we do that I should like to examine another witness here from the same company, and I have therefore finished with Mr. Knudsen.

The CHAIRMAN. Perhaps members of the committee would like to ask Mr. Knudsen a few questions.

Senator KING. I have none.

The CHAIRMAN. It is now noon, and if there are no questions I wanted to find out how many of the members of the committee desire to ask questions before I announce the recess, you see.

Mr. Cox. Mr. Knudsen would like to get away, if he could.

Mr. KNUDSEN. It is quite all right. I will stay.

The CHAIRMAN. We would like to suit your convenience if we can.

Mr. Arnold would like to ask a few questions. Are there any other members of the committee who would like to ask questions? Dr. Lubin will. Apparently there won't be many more questions, so we will remain in session for a few moments longer.

Mr. ARNOLD. Mr. Knudsen, you stated that the problem of patents, insofar as it affects invention, is entirely different with big units than with small units—big industries rather than small industries.

Mr. KNUDSEN. Yes.

Mr. ARNOLD. That, as a matter of practical effect, the big industries would have to carry on their research without the patent law.

Mr. KNUDSEN. Yes, sir.

Mr. ARNOLD. That the real problem is only with the small inventor.

Mr. KNUDSEN. Well, it depends on what kind of invention you are talking about.

Mr. ARNOLD. In general. Doesn't that indicate possibly a different policy in the patent law might be pursued as to those two separate problems?

Mr. KNUDSEN. I don't know.

Mr. ARNOLD. It might indicate that.

Mr. KNUDSEN. I will have to refer that to Mr. McEvoy.

Mr. ARNOLD. And might it not indicate the possibility of considering a different policy as to patents which come from large group research and patents which come from a single individual. The question is somewhat argumentative. I simply wish to see if you have any pronounced dissension from that idea.

Mr. KNUDSEN. I tried to hold back. I don't see how you can possibly have that kind of clause in the law.

Mr. ARNOLD. If we could, from an economic standpoint it would be beneficial.

Mr. KNUDSEN. I even couldn't answer it from an economic standpoint. I don't see how you can restrict brains to an individual or a group, a small one or a large one.

Mr. ARNOLD. You don't see how we can implement a patent policy which would have a different effect on large industry than it did on small?

Mr. KNUDSEN. I don't see how.

Mr. ARNOLD. As a practical matter you don't see it, but as an economic matter it would be a good thing if we could.

Mr. KNUDSEN. Even that I wouldn't be able to answer, sir.

Mr. ARNOLD. That is all I had to ask.

Dr. LUBIN. Mr. Knudsen, I was very much interested in your statement relative to the great advantages of free exchange of patents through the development stage of an industry, but after the industry passed that stage the advantages disappeared, and that you approved a policy of not sharing new patents after the industry had got on its feet and became an established procedure. Does the General Motors Corporation manufacture electric refrigerators?

Mr. KNUDSEN. Yes, sir.

Dr. LUBIN. Does it manufacture oil burners?

Mr. KNUDSEN. Yes, sir.

Dr. LUBIN. Does it manufacture air-cooling devices?

Mr. KNUDSEN. Yes, sir.

Dr. LUBIN. Would you say any of those are in the developmental stage right now?

Mr. KNUDSEN. I think air cooling is.

Dr. LUBIN. Is there any exchange of patents in air cooling?

Mr. KNUDSEN. I don't think we have many patents in air cooling, that I know of.

Dr. LUBIN. But such patents as are available——

Mr. KNUDSEN (interposing). It is a combination of known devices standard to air cooling; it is a combination of devices now in use in other industries.

Dr. LUBIN. There are no patents of any particular merit that give any particular type of burner any particular advantage?

Mr. KNUDSEN. I can't think of any of my own recollection.

Dr. LUBIN. I wanted to get your opinion as to whether you felt there might have been faster progress in the development of these newer industries had they had the same system of patent exchange that you had in automobiles.

Mr. KNUDSEN. I would have said yes, because it did work in the automobile industry, sir.

The CHAIRMAN. Would you care to state your opinion, Mr. Knudsen, as to why the cross-licensing policy was adopted in the first place, and then abandoned?

Mr. KNUDSEN. Well, it would only be an opinion.

The CHAIRMAN. I realize that.

Mr. KNUDSEN. I was not in the councils of the industry when the cross-licensing agreement was made. I was working down in the shop.

The CHAIRMAN. Your experience is so great that your opinion will have very much weight, of course.

Mr. KNUDSEN. I think it was in order to leave a little time to do the work, because they were having trouble in the plant all the time with the cars they were making, and I presume the patents, or so-called suggestions for patents, were coming so fast and furiously that they didn't have time to do any work for worrying about patents, and I imagine that had something to do with it. It is only an opinion, sir. I don't want you to think it is frivolous.

The CHAIRMAN. We understand it is not frivolous, Mr. Knudsen, and I think it is a very valuable expression. Now, then, with respect to the abandonment, what is your opinion?

Mr. KNUDSEN. Well, naturally when you have made an article for a certain number of years, you always feel you are making it a little better than somebody else, especially if it is in a highly competitive industry.

The CHAIRMAN. Would I be correct in inferring from what you have said that in the opinion of most of the competition in the motor industry, patents which are now possible of development would merely have effect upon style and pattern, rather than upon the basic development of a car?

Mr. KNUDSEN. I don't know about that, because naturally we learn as we go along, and some of us might get an idea that others hadn't thought of before, but the majority of the developments are what I call of the improvement nature.

The CHAIRMAN. They are incidental and not basic. You have testified that in your opinion it would not be impossible to develop a revolutionary patent which would put any particular company out of business.

Mr. KNUDSEN. If I said that, I didn't mean it. Naturally everything is possible. We might get a revolutionary invention in the motor-car industry, I don't know.

The CHAIRMAN. That leads me to the question which I have in mind. Approximately what is the investment of General Motors? What is your capital investment, approximately?

Mr. KNUDSEN. Twelve hundred million dollars.

The CHAIRMAN. How many employees do you have?

Mr. KNUDSEN. 250,000.

The CHAIRMAN. How many stockholders do you have?

Mr. KNUDSEN. About 360,000.

The CHAIRMAN. Suppose some one of your competitors were tomorrow to develop a revolutionary patent which would make it impossible for General Motors, without the use of that patent, to compete with the producer who had the revolutionary patent, what would be the effect of that, in your opinion, upon your company, your stockholders, your employees, and what should the Government do, if anything, about it?

Mr. KNUDSEN. If such a thing were possible, we certainly would all either make a deal for license under this revolutionary patent or you will see a lot of people working 7 nights a week until we have found something.

The CHAIRMAN. If you couldn't get the deal for a license, if the patentee, in other words, were to insist upon his exclusive right for

17 years, and you were unable, working nights for weeks, to develop a comparable invention, then what would be the effect upon General Motors, its stockholders, and its employees?

Mr. KNUDSEN. Very bad.

The CHAIRMAN. Thank you very much.

(Mr. Knudsen was excused.)

(Whereupon, at 12:10, a recess was taken until 2 p. m. of the same day.)

AFTERNOON SESSION

The committee resumed at 2:15 p. m. on the expiration of the recess.

Present in addition to those previously listed: Mr. Ferguson.

The CHAIRMAN. Mr. Cox, are you ready to proceed?

Mr. Cox. Yes.

The CHAIRMAN. The meeting will come to order. Will you be good enough to call your first witness?

Mr. Cox. Mr. Kettering.

The chairman will swear you.

The CHAIRMAN. Do you solemnly swear the testimony you are about to give in this proceeding shall be the truth, the whole truth, and nothing but the truth, so help you God?

Mr. KETTERING. I do, sir.

TESTIMONY OF CHARLES F. KETTERING, VICE PRESIDENT, GENERAL MOTORS CORPORATION, DAYTON, OHIO

The CHAIRMAN. All right, Mr. Cox, you may proceed.

Mr. Cox. Mr. Kettering, will you give your name and address?

Mr. KETTERING. Charles Kettering, Dayton, Ohio.

Mr. Cox. What is your present occupation?

Mr. KETTERING. Head of the research division, General Motors Corporation.

Mr. Cox. How long have you held that position?

Mr. KETTERING. I think the laboratories were organized in 1920.

Mr. Cox. How long have you been connected in one capacity or another with the motorcar industry?

Mr. KETTERING. Since 1909.

Mr. Cox. What did you do before that?

Mr. KETTERING. I was with the National Cash Register Co.

Mr. Cox. Is that the first employment you undertook after you finished your training?

Mr. KETTERING. I was in the telephone business a little bit, and then went into the National Cash Register Co.

Mr. Cox. You are an engineer by profession?

Mr. KETTERING. Supposed to be.

Mr. Cox. Will you tell us briefly what your duties are in the research division of General Motors?

Mr. KETTERING. Well, it is supposed to be running the laboratories, but the main problem we have, of course, is the selection of the proper research problems. That is really the most important thing we have to do.

Mr. Cox. That department carries on all of the research and development work for the General Motors?

Mr. KETTERING. Oh, no, no. May I explain how we are set up?

Mr. Cox. Certainly; I wish you would.

Mr. KETTERING. Our research department is set up as an entirely independent organization and it acts more as a general or central consulting organization for the corporation. Each individual industry has its own engineering and development department for that industry, and we try to work on the general problem. I think I can best explain it by the way our budget is set up. Forty percent of our budget is for consulting services with the divisions; 40 percent is for more or less advanced engineering; and 20 percent is for the so-called pure science or long-shot problems.

Mr. Cox. To illustrate that difference that you have just explained, is there a separate research organization for that part of the General Motors business which manufactures refrigerators?

Mr. KETTERING. Oh, yes; they have a very fine research and engineering department for that job alone, but we act as consultants with them.

Mr. Cox. I see. How many employees do you have in this organization?

Mr. KETTERING. About 500.

Mr. Cox. Are they all engineers?

Mr. KETTERING. No; we have all types of men; we have physicists, mathematicians, engineers, and fine mechanics, and all that sort of thing.

Senator KING. They are all skilled men?

Mr. KETTERING. Yes.

Mr. Cox. As a result of the work which you carry on in your organization, Mr. Kettering, or in your department, to be more precise, are inventions made on which patents are required?

Mr. KETTERING. Yes.

Mr. Cox. And does General Motors take out those patents?

Mr. KETTERING. Yes.

Mr. Cox. What arrangements does General Motors have with the employees with respect thereto?

Mr. KETTERING. We all sign the regular patent agreement that we have with an institution of that kind; we assign all the patents directly to General Motors.

Mr. Cox. Is the employee who makes an invention of that kind rewarded in any way beyond his usual compensation?

Mr. KETTERING. We usually do; yes. You see, when you are working on an invention—well, we don't work on inventions; we try to solve some industrial problem; try to make a new piece of apparatus. Now, you never know what inventions are going to be useful and what are not, because as you come upon the problem, you can't tell what is important and what is not important, so we have to kind of study the whole thing on the whole front. It may go off at that angle or this angle. What we would rather do is to try to reward the whole laboratory, to keep the individuals working together. If you gave the reward to a particular individual for his particular invention, then he would be secretive about the thing, so we try to reward the whole laboratory, if they do good. In other words, if he makes some things

that are valuable, we reward the laboratory, because one department may make an important contribution one year and another department another year; but then we always give a little particular bonus to the fellow who did that job.

Mr. Cox. In other words, you have both a collective reward and an individual reward.

Mr. KETTERING. Yes. You have to keep the collective reward in order to keep the thing from crystallizing and segregating. A one-man invention isn't very possible these days, because there are so many ramifications that we have to work together as a group. I think that one of the hardest problems we have had is to get scientific men to sit down and work on a common problem, because their whole training has been individualistic, but if you get a good problem and can divide it up into a number of sections and assign the metallurgical department to the metallurgical part and assign another problem to the physicist and another to the chemist, and so forth, then our particular job is to correlate that so when their work comes together, it is the thing we are trying to get made. It works out pretty nice. You see our stuff fails so often; it is about 99 percent failure, and our biggest problem is to keep the men enthusiastic, especially a young fellow will come in and set up something and develop it, and it doesn't work, then he is all down. We say, "You are just an amateur failure; you have to learn how to fail over and over and over again," but after they understand that, there is no trouble about working together then.

Mr. Cox. That research is really carried on, then, as a collective enterprise?

Mr. KETTERING. It depends entirely on the problem; sometimes the problem will be a particular problem. Suppose we were working on the metallurgy of that particular thing, that would be assigned to an individual in the metallurgical department. If that happened to be a part of this, then it would have to be correlated to that, don't you see? But our job as managers is to develop the principles of correlation.

Mr. Cox. Do you have any opinion, Mr. Kettering, as to whether the possibility of the acquisition of a patent plays any part in stimulating the men who work under your direction?

Mr. KETTERING. Oh, yes.

Mr. Cox. You think it does?

Mr. KETTERING. The younger fellows, you know, the United States patent—it is just like a diploma to those boys. We like to see them get them.

Mr. Cox. Well, patents in each case, however, are acquired by the company.

Mr. KETTERING. Sure. This fellow took it out, you see.

Mr. Cox. He applies for it.

Mr. KETTERING. Yes.

Mr. Cox. You have made a number of inventions, haven't you, Mr. Kettering?

Mr. KETTERING. Yes; quite a number.

Mr. Cox. Have you ever acquired any patents on those personally?

Mr. KETTERING. I don't think I ever took out a personal patent. I may have one or two, but not that I could name offhand.

Mr. Cox. But patents were taken out on those inventions by the companies.

Mr. KETTERING. Whatever company I was with; yes. That is the way I like to do.

Mr. Cox. When you were making those inventions did the possibility of the acquisition of a patent serve to stimulate you in your work?

Mr. KETTERING. No; I wouldn't say it did; I would say it came more as a reward rather than as an incentive, because when you are working on a problem, you see, I have had to give an order to get people to understand. They say, "What is research?" Well, a research worker is a fellow who is working on something he doesn't understand—he is trying to solve a problem.

The CHAIRMAN. That might be said of most of the members of this committee, perhaps.

Mr. KETTERING. I can't go outside of my own technic. [Laughter.] So you never know when you get the problem solved whether there is anything that is patentable in there or whether there isn't, so if you start out to make an invention for the sake of making an invention it will never be a very good one. An invention comes as really the secondary thing of having accomplished a useful thing. You see, that is what you start out with, by saying that a patent is a new and useful improvement, but to start to make an invention for the sake of making an invention, I don't think you would get a very good one. It has to be worked out as part of the general problem.

Mr. Cox. But is it your opinion that the patent as such nevertheless does serve to stimulate the work by inventors?

Mr. KETTERING. As I say, it comes to them, especially these younger boys, as a reward of merit and it is very highly prized, and of course patents are very valuable things in many different ways. It has been mentioned here that there are many different ways by which a patent can be valuable.

Mr. Cox. You spoke a moment ago of the fact that most of your inventions you had assigned to the corporation which employed you under the terms of some agreement you had with them. Did the fact that you knew that any invention you might make would be assigned to the corporation make any difference to you?

Mr. KETTERING. Not a bit.

Mr. Cox. You work just as hard?

Mr. KETTERING. Oh, absolutely, because if the invention is going to be of any use, it has to be translated into a product and there is such an enormous step between the patent and the product. Mr. Knudsen mentioned this morning the three steps, the idea step, the development step, and the production step. We call that second step the "shirt-losing" zone, the development zone. It is a very difficult zone to work in because, first of all, you haven't any market yet, and yet you have to put a product out that is good enough so that somebody buys it and it will be all right and yet you have no commercial experience on it at all, and that feeling of the road from the patent out through to get a successful product is a very, very difficult thing. It isn't understood at all, and that is where industry has got to take their chances, and you have got to spend a lot of

money in there sometimes before you get a really satisfactory product.

Mr. Cox. Then you think that the protection the patent gives is particularly important in what you call the "lose-your-shirt" period?

Mr. KETTERING. That is right, in that development period.

Mr. Cox. Will you develop a little more at length as to exactly why you think it is important in that particular period?

Mr. KETTERING. I can tell you two reasons. It doesn't seem to me it makes any difference whether it is an individual or a corporation, or what not, as I said a while ago, when you start out to do a thing, you are an amateur at it; the first time you do anything you are an amateur at it, so you are always an amateur at doing these jobs. That patent is a very important thing because you have to spend some money to make tools and build a factory and to go into production. After you go into production, you find out from the experience you learned in the field, from the commercial operations, that if you had it to do over you wouldn't do it that way. If you don't have some protection for that thing, a competitor can start out with that fresh information and he could bypass this thing, and so you have to have some protection while you are getting the thing straightened out.

I think the patent protection is just as good for the big organization in that development period as it is for the individual.

Mr. Cox. Would you say that so far as the stimulation that is offered by a patent is concerned, that there is any difference between the development and research work that is carried on by a large corporation, such as General Motors, and the work which is carried on by an individual inventor or small organization?

Mr. KETTERING. I don't think so. As I told you a while ago, we don't take these problems with the idea that we will get patents on them. We take these problems with the idea that we will get a new product or new type of product. If we get it, and there are new and useful developments in it, those are the things upon which we get patents.

Mr. Cox. You would continue to do this work, as far as your own organization is concerned, regardless of whether you could obtain patents or not?

Mr. KETTERING. I know we would do it so far as our own organization is concerned, and I know I would do it as an individual. I think perhaps the psychology of an inventor is not very well understood here. An inventor is a fellow who wants to do something because he doesn't know why he wants to do it but he has an aptitude for it, just like a fellow who wants to play a musical instrument or paint a picture. He would invent whether he got a patent or not and he doesn't know why he invents. He has an aptitude for doing that thing and he wants to do it and enjoys doing it.

Mr. Cox. In other words, he invents with his eye on the device and not with his eye on the patent.

Mr. KETTERING. That is right. If you try to invent with your eye on the patent, you never get very good patents, because they won't be so useful; but if you invent with the idea of protecting this new thing—you have a problem and you say, "I would like to have a new tool for that," and if I develop the new tool that does your work

all right and that happens to open up a new field, you say, "You ought to get a patent on that." That is the only good patent there is.

Sometimes there are half a dozen ways of doing a thing after you start to do it. When you put your money on that way, you take out these auxiliary patents as sort of protective things you didn't find yourself, and I think that is all right, too.

Mr. Cox. Would you say then that the patent monopoly is probably more important to the man who is attempting to develop or put an invention into large-scale production than it is to the inventor?

Mr. KETTERING. Oh, yes; because the amount of capital that you have to put in some of these things sometimes is perfectly appalling, because you have to make a set of tools. You make a few hundreds and you find out you have to change the whole thing. Any development of a new product is a very expensive thing because, you see, your customers are the fellows who really tell you what your product ought to be, and when you haven't got any customers on that product you have to use your best judgment as to what you think they are going to like. You have got to make the best thing you know how to make, put it on the market, get the customer reaction on it, and he comes back and says, "Why didn't you make this this way instead of that way?" You never thought about it, because he doesn't look at it the way you do; he looks at it from his particular standpoint. You find a good thing to modify and you have to throw your tools away and start all over. We usually have to start about three times with any new product before we really get something that has an ability to broaden in the field.

Mr. Cox. Then you would say that so far as the present patent law serves a useful purpose, it is probably more useful in protecting the development and production of an article than it is in stimulating the individual genius conceiving the article?

Mr. KETTERING. I should say so, yes; but I can't weigh these things, but I still think it has a good stimulating effect, too.

Mr. Cox. Now, Mr. Kettering, you have worked during your life in a number of industries, haven't you?

Mr. KETTERING. Yes.

Mr. Cox. You started out in the telephone business and you had something to do with the cash-register business, and then in certain branches of the electrical industry you worked on light and the self-starter.

Mr. KETTERING. I developed the self-starter.

Mr. Cox. And finally in the motorcar industry, and I assume that in all your experience in those different industries you have had an opportunity to observe the practices which have been followed in those industries with respect to patents.

Mr. KETTERING. Well, I have never paid very much attention to the patent policy, because I am one of those one-track individuals that work on the apparatus rather than the other.

Mr. Cox. Throughout your experience in these different industries, has it ever been your observation that the patent has been used as a means of controlling or preventing competition in any one of the industries?

Mr. KETTERING. Not that I know of; no.

Mr. COX. You have no experience of that kind?

Mr. KETTERING. No.

Mr. COX. Has it ever been your experience that there has been any abuse of the patent monopoly in the sense of using it to maintain price?

Mr. KETTERING. Not in any of the organizations I have been associated with, I have never known of that. It is surely not true in the motorcar industry at all.

Mr. COX. Have you done anything about the cross-licensing agreement existing in the motorcar industry?

Mr. KETTERING. Not a thing.

Mr. COX. Do you have any opinions on that?

Mr. KETTERING. No; I haven't. May I make this suggestion? You brought out the three ways it was used.

Mr. COX. I am coming to that.

Mr. KETTERING. All right; I won't jump to that.

Mr. COX. I was going to take that up next and ask if you recollected we have had three different ways of describing the use of patents here.¹ May I ask whether you would care to express an opinion on the merits of those three systems?

Mr. KETTERING. I couldn't express any opinion on the merits of them, but I think there is a logical reason for the three different things. You see, depending on how you start and how you have been organized, you look at these problems in different ways. We have that same thing in connection with engines in General Motors. We have some divisions that think a valve-in-head engine is the only thing that is any good. We have equally successful concerns that think only an L-head engine is a good thing. If you try to take an L-head engine and put it with a valve-in-head engine, or vice versa, neither is any good.

I think that different way of looking at this thing is a perfectly normal reaction in the method of having approached the problem. The composite is very likely to be the best, a little bit of each one of them.

Mr. COX. That remark of yours is rather interesting, Mr. Kettering. I am rather puzzled as to how you could have a policy where you have, for example, first a policy of licensing anyone under a patent royalty free at one extreme, and at another extreme, if I may use those words in no invidious sense, you have the policy of retaining a patent and charging a royalty for a license.

Mr. KETTERING. I think every individual case has to be treated on its specific merits. If you treat them, you will find some fall into one class, some into another, and some into the other class. I don't believe you can give a general classification, because the method of manufacturing, the marketing organizations, and all of those things have a big influence on how much value you place on these things for any individual invention.

Mr. COX. You say "treat each case separately." You mean invention.

Mr. KETTERING. That's right.

Mr. COX. You think, for example, a policy that might be possible in a basic invention might not be the best thing in the case of an invention on an improvement.

¹ See *supra*, pp. 256-313.

Mr. KETTERING. That is true.

Mr. COX. Would you say as a general proposition it would probably be more desirable in case of a basic invention to use a policy which Mr. Ford has tried, of licensing everyone royalty free?

Mr. KETTERING. I say that would depend altogether on the state of the art, the size of the company, and your financial condition, because if you were a small concern and you got that basic thing and you had no sales organization and very little capital, you would have to depend on that patent or you couldn't get into business. Another concern that had a sales organization, that had good factory technic—the latent value might be very much less for them.

Mr. COX. You think, then, there might be situations in which it would be proper to permit a person to have an absolute monopoly on a device which was basic in an industry, in the sense that no one could operate without it?

Mr. KETTERING. Well, I think that is true, especially if it is a young art, you see, just starting out.

Mr. COX. You think at that point, the monopoly on the basis—

Mr. KETTERING (interposing). Yes, I think that is pretty important.

Mr. COX. You weren't here yesterday when Mr. Ford was testifying, in the morning, but he described the situation which existed in the motor car industry in the early days when there was a patent which purported to cover the entire idea of an automobile; any combination of a carriage with a internal combustion engine was claimed for in the patent. Mr. Henry Ford, according to the testimony, wanted to get a license under that patent to manufacture automobiles, and he was refused.¹ If that patent had been held valid and infringed, as it was not, don't you think that might have had an unhealthy effect on the motor-car industry?

Mr. KETTERING. Of course that is one of the most controversial kinds of patents; combination patents are very controversial always.

Mr. COX. That was a basic patent.

Mr. KETTERING. Oh, no. I wouldn't think that a basic patent. It is a combination patent.

Mr. COX. It covered at least the basic idea of an automobile.

Mr. KETTERING. I know, but I still wouldn't consider that a basic patent.

Mr. COX. Then you are not speaking, when you speak of a basic patent, necessarily of a patent which covers the whole idea of a particular commodity or anything of that sort.

Mr. KETTERING. Well, but you see, I think if you had gone back, the idea of having an engine run a motor car or wheels or something like that was much older. Here you had the railway locomotives and all that sort of thing. I don't want to get into a discussion of the details, but you had self-propelled vehicles long before the Selden patents. I wouldn't consider that a basic patent. That was just another kind of automatic transportation, you see.

Mr. COX. Do you think that it might be proper for a holder of a patent to have a monopoly, even though by the use of that monopoly he might destroy a large investment in capital and increase unemployment? I have in mind the situation the chairman put to Mr. Knudsen

¹ See *supra*, p. 268.

at the conclusion of his testimony before the committee rose. Did you hear that series of questions?

Mr. KETTERING. Yes. I don't see how that thing could ever happen, you see, because any very, very radical new departure doesn't come suddenly. They come very slowly and you couldn't just reach in your pocket and flash a new one out like that, especially in a highly developed art like the automotive business. You see, we have made about 40 or 45 million automobiles, and the engineers have scraped those specific bones pretty carefully to get them better and cheaper and easier to make. For somebody to come and flash a brand-new principle is almost inconceivable. It would take him a very long while to do that. The next thing, he would have a terrible difficulty getting it manufactured, because it takes a long while to educate men how to manufacture a thing which is radically different.

Take a thing like this new injector we developed for the Diesel engines. We had to start out with an absolutely new bunch of men, rather young men, who didn't have any preconceived notions about that thing, to get them to make that. When you come to a radically new thing it takes 4 or 5 years to get men trained to think down that alley. They always want to make the new thing like the old one and it takes a long while to overcome that. That is one of the most tedious problems we have in getting a new thing out.

Mr. Cox. Reverting for the moment to the matter we were discussing a while ago, about the incentives which the patent offers to the inventor, do you think there is any particular magic in the 17-year monopoly? I am speaking from the point of time now. Would 8 or 9 or 10 years do just as well?

Mr. KETTERING. Again I think you would have to take the individual case, because if an inventor is very smart and alert, right up to the minute, 17 years isn't long enough, because he will be ahead of the times. I just mentioned one the other day; this Funk developed this nicotinic acid, which was a sort of correlation of vitamin B. He did that in 1911 and the medical fraternity didn't start to use that very much until about 1933, because there were some corollary things that hadn't been done. There was a man, if he had had a 17-year patent on that, who wouldn't have got anything out of it at all. If you are ahead of your times you have to have more than 17 years. If you are behind the times, perhaps a shorter time would be sufficient. That is a very difficult thing to tell, whether you are ahead of or behind the times.

Mr. Cox. The more radical an invention is the more time the inventor needs for people to accept it and put it into production.

Mr. KETTERING. If the new idea happens to be negative to the present trend, he would have a much more difficult time getting that into production, because it would be opposite to what is in the textbooks and what people think about it, and that makes it a pretty difficult thing, and that fellow needs protection more than the fellow whose problem is obvious. To do something opposite to the engineering trend is a very, very difficult job, because everybody thinks you are wrong and they say "If you would turn this over that way instead of this way, it would be all right," yet it won't work that way.

Mr. Cox. I think that is all.

Mr. ARNOLD. Mr. Kettering, in your testimony you have constantly emphasized the importance of treating the differences in different industries in different cases different, and that leads me to ask you a few questions frankly designed to show the relationship of this hearing presented by the Antitrust Division with the possible use of the antitrust law. I should like to start by asking you whether there isn't a great economic difference between patents on gadgets and patents which relate to some process to such an extent that they might be restraints on industrial arts.

Mr. KETTERING. I think there is a great deal of difference in the social significance of the two kinds.

Mr. ARNOLD. As an illustration of that, I hand you a little patent that is pending which I cut out of the New Yorker, a rather attractive coin knife. From an economic point of view, it doesn't make so much difference how long that patent lasts, does it?

Mr. KETTERING. No.

Mr. ARNOLD. In other words, a problem like that is a problem of equitable distribution of the profits between the inventor and the person furnishing the capital, and so on, isn't it?

Mr. KETTERING. Yes.

Mr. ARNOLD. And that is a problem of an equitable patent law. I want to say that particular problem of an equitable patent law is not the problem to which these particular hearings are directed, and I wanted to make clear that difference.

Now, Mr. Kettering, you never know in advance whether a particular patent is going to be just a gadget or whether it is going to have a tremendous influence on a process, do you?

Mr. KETTERING. Well, I say at least you could know from the type of problem whether it was in the gadgetary class.

Mr. ARNOLD. Oh, in that extreme case; yes; but whether a patent was unimportant—

Mr. KETTERING (interposing). You can't tell until the thing goes into production.

Mr. ARNOLD. You never find out until afterwards. I think you would further agree with me when I state that any patent law drawn from the point of view of an equitable distribution of the profits of an idea, will tend to become distorted by patent-minded persons.

Mr. KETTERING. Well, I don't know about that.

Mr. ARNOLD. That is the history of almost all general regulations.

Mr. KETTERING. I suppose that is like salesmanship, they try to think their product is the best.

Mr. ARNOLD. In other words, there will always be people trying to make a profit out of a law as opposed to those people whom you are talking about, the real inventors who are trying to improve the process.

Mr. KETTERING. Oh, I think you will always find that in any operation.

Mr. ARNOLD. And it is very difficult, don't you think, to solve that problem by any general formula?

Mr. KETTERING. Yes; my experience with patents has been with each one of them and the circumstances around it are usually quite different. Of course, we can't in engineering get very many good

general laws, so we have to take a specific case, and I think maybe you have to do that with human relationships, too. I am not a very good psychologist, so I don't know that thing very well.

Mr. ARNOLD. Therefore, in administering even an equitable, even the most equitable patent law that you can possibly devise, there needs to be some instrumentality which will stop the use of that law in such a way as actually to restrain trade or to restrain the industrial arts.

Mr. KETTERING. Well, of course, that seems to be clear out of my field.

Mr. ARNOLD. Don't you think that that is necessary on those assumptions?

Mr. KETTERING. Well, just from a perfectly general thing it looks like it is, although as I say I don't know enough about that legal phase of the thing so that my opinion wouldn't be worth much on that.

Mr. ARNOLD. I think the opinion of an inventor upon a legal question is certainly worth something, probably more than the opinion of a lawyer.

Mr. KETTERING. You compliment us when you say that.

Mr. ARNOLD. I hope so.

Mr. KETTERING. Our bosses don't think that well of us.

Mr. ARNOLD. Let me present an analogy. A corporate merger is a legal thing which requires a certain amount of inventive and organization genius, doesn't it? The antitrust laws are supposed to prevent unreasonable corporate mergers, that is, those which tend to restrain competition and which can't be justified on the grounds either of efficiency or orderly market. In other words, they stop the use of an otherwise legal device in a particular case because the facts of that case show it has an uneconomic effect. Would you conceive that the same principle could apply to patents?

Mr. KETTERING. Well, I could conceive it; I don't know whether it exists or not.

Mr. ARNOLD. I am not referring to the present law; I am asking you no opinion on the present law, but would you not consider that that is a possible way of getting the case by case differentiation between these situations which you have constantly emphasized in your testimony?

Mr. KETTERING. Well, I say that is taking me out of my field. I don't think my judgment is worth very much.

Mr. ARNOLD. I think it is worth a great deal, Mr. Kettering.

Mr. KETTERING. Well, I don't know how to answer that.

Mr. ARNOLD. Well, you would at least like to see some method devised which would enable the treatment of this patent problem to be applied differently in different industries and in different cases.

Mr. KETTERING. Well, if the merits of the thing demanded such things, I certainly would be in favor of it.

Mr. ARNOLD. And you have already indicated that there was an enormous difference between patents and between periods in the patents and between particular industries using the patents which would require a case by case treatment, haven't you?

Mr. KETTERING. Yes.

Mr. ARNOLD. These questions, frankly, Mr. Kettering, have been somewhat argumentative on my part, but they are intended to show

the relationship of this hearing with the Antitrust Division, and to show that there are two problems here, one an equitable patent law to which many of the questions have been directed, and one a possible treatment under the antitrust law which would apply somewhat the same standards to the use of the legal privilege of a patent that they do to any other legal privilege which is used to restrain trade.

THE CHAIRMAN. Mr. Patterson, I invited you to speak because you are representing the Department of Commerce, to which the Bureau of Patents is assigned.

MR. PATTERSON. Mr. Kettering, I have several questions here upon which I should appreciate your opinion and advice. Did I understand you to say a few moments ago in substance to Mr. Arnold that it is generally impossible for anyone to predict the importance and the effective role a new invention will have in an industry when the patent is granted? I didn't quite get that.

MR. KETTERING. If it is granted early, before the product has had a chance to go to the customer, it is pretty hard to tell.

MR. PATTERSON. Did I understand you to say that you are unaware of any instance where a revolutionary invention has broken into an industry with such suddenness as to cause a serious dislocation of established industry?

MR. KETTERING. I don't know of any; there may have been such things, but I am not familiar with them.

MR. PATTERSON. Mr. Kettering, there was some testimony yesterday to the effect that practically all of the valuable and worthwhile inventions came from the industrial laboratory and very few from the outside. Do you coincide with that?

MR. KETTERING. Oh, no, no, no, no; there are a lot of very brilliant people outside of industry. We say we don't lock our laboratories up for the reason that we lock so much more out than we can in. We don't have any idea that that is so at all.

MR. PATTERSON. Here is my next question, Mr. Kettering: Conceding for the sake of argument that the liberal licensing of patents between competitors in industry may under certain circumstances be beneficial, just for the sake of argument for the record let us concede that, as between voluntary agreements between members of the industry on the one hand and agreements under compulsion of law on the other, which procedure do you prefer, having in mind, of course, the development of an industry as well as the consuming public.

MR. KETTERING. You are asking me a question that belongs to the administrative and executive end of business, and I am not considered a very good administrator or executive officer, so I don't think I could answer that, because I wouldn't know.

MR. PATTERSON. If the protection now afforded under the patent laws was withdrawn or substantially weakened, what would be the general effect on industrial progress and advancement, and specifically is it likely that your company, General Motors Co., would invest as much money or be as active in experimentation and research?

MR. KETTERING. I think we would be just as active, because you see we are so far behind in this development work. You see we have got this peculiar situation where we have got a lot of men out of work and a lot of money out of work and a lot of material that is

not needed, which means that we haven't got enough projects, so we are very far behind on the development end of things and anything that you can do to encourage development so that we can get these men and material and money all back to work, that is the biggest thing. We are away behind technologically, we are not ahead at all, and I am ashamed of our kind for being that way, too. We haven't done a very good job.

Mr. PATTERSON. Thank you, Dr. Kettering.

Senator KING. Were you speaking of the automobile in that last statement of yours?

Mr. KETTERING. I am talking about the whole technological problem, Senator. We have done pretty well with our thing because we have had the yearly automobile shows and that has helped to accelerate that development, but to get new things started is a very difficult thing and that is the thing I am worried about, I am trying to invent a way to get new industries started. There are so many new things that can be done; we know so little about almost anything; that is the thing that I am trying to get going.

Senator KING. Laboratories such as yours are conducive to new investments and the development of new industries or the extension of industries that are already in existence.

Mr. KETTERING. Well, the principal thing Senator, that we work on is the development of new industries. There are two problems in the industry; from the time of the idea through the development standpoint, and then when it gets on what we call a profit-and-loss basis that industry will then go on its economic motive.

That is where we work. We have taken it from ideas up to where they get to a profit-and-loss basis. That is the hard job to do, so we only try to develop new industries. The old industries will take care of themselves just by the nature of the demand of the public for the product, through modifications and a normal activity of the industry itself.

Senator KING. I suppose many inventions which have been patented have been brought to your attention. What would you say as to the proportion that has been brought to your attention that are feasible or useful?

Mr. KETTERING. Not very many, and there is a very definite reason for that.

Senator KING. State it, can you?

Mr. KETTERING. I don't know how many, but we get thousands of them every year. Most inventions that come to you have to do with locality—I am speaking about a motorear invention. If a fellow lives in a hilly section of the country, he will invent things that he thinks would make the motorear better for the hilly country; if he lives in a cold country he will have devices for that; if a warm country, for that. When our motorears go out of the factory, we don't know where they are going to go, and there are some very bright young fellows doing that work. We don't say, "That is all right for Pittsburgh or Seattle or something like that." We take time to explain to that fellow why it is a thing we can't adopt generally, and we try to get him to go back and get a broader survey of the problem.

A lot of fellows don't understand the industry situation, the fact that our cars may be sent export or this, that, or the other way.

try to take the opportunity of encouraging this fellow and showing him what the real problem of getting a new thing is, because there are a lot of intelligent people in the world.

Senator KING. What proportion of the patents taken out by your organization have proven of value?

Mr. KETTERING. Not very many.

Senator KING. I understood you to state in your opening remarks that it was 1 out of 100, was it not?

Mr. KETTERING. I don't think we do that well. You see, the reason for that is because when you are coming up on this problem, before you break through and it takes definite shape, you don't know what is important and what is not important.

I wish I could get this point over, that when you are doing an invention, when you are working on a new product, you are a very rank amateur at it. It is the first time anybody tried to do it. We never do a good job that way, and so you have notions about what it was today, and when you get experience tomorrow that changes your point of view on the thing, and finally when you get the thing up so the public gets hold of it, they are the people who tell you what they want to have.

Senator KING. Isn't it true that most of the patents scarcely rise to the dignity of accessories, but are some little improvement, a very slight improvement upon a basic product?

Mr. KETTERING. There are many like that; yes. I suppose that the gamut of the patent values is just about the gamut of people; that is, they will think in terms of about what their requirements are, and that sort of thing.

Senator KING. Are there not many patents that are purely accidental?

Mr. KETTERING. Those I prefer to call discoveries rather than inventions.

Senator KING. Probably discovery is the proper term. I have in mind, and doubtless you have in mind or are familiar with, the process by which infinitesimally small particles of copper ore have been recovered when the copper mines have failed to be worked by any other method—by the oil-flotation method. That is a pure accident.

Mr. KETTERING. That was a discovery; yet, if the fellow hadn't been working in that field, he wouldn't have made the discovery. You get these accidental things, but you only stumble when you are moving around in the vicinity of the thing.

Senator KING. As I understand your testimony, bringing it down to summation, it is that the patent system, though it may have some imperfections, perhaps many imperfections, it has been of importance in developing the industries of our country.

Mr. KETTERING. Marvelous.

Senator KING. And no efforts ought to be made to destroy the patent system.

Mr. KETTERING. No. I should say let the patent technicians, the Patent Office, the patent lawyers, and other people fix up their machine. It is like anything; as time goes on, improvements have to be made. It is a good machine basically, and I don't know what I would suggest, because I have taken out many patents and worked with the Patent Office for many years. I don't know what I would suggest, but I would sooner leave it to the people whose business it is to work

in that field to make the corrective things, whatever needs to be done.

Senator KING. You stated to Mr. Arnold that it stimulates new discoveries, new inventions—the fact that you may get a patent and if it happens to be of use, obtain profit thereby.

Mr. KETTERING. It has a great value. I can't weigh the respective factors in percentages, but it is of value to the large corporation, to the individual, and to any kind of group, because you people are down here at Washington all the time, you live here, but remember when we people out in the country get a document from Washington, it is of very great importance to us.

Senator KING. Especially if it is a tax notice.

Mr. KETTERING. Oh, no; we don't object very much to those, either.

Mr. ARNOLD. Referring to the different importance of the patent laws at different stages in the development of an article, I would like to ask you a few specific questions that I don't know anything about. Do you believe it would serve the public interest if patents in Diesel engines, for example, were cross-licensed at this time?

Mr. KETTERING. Of course, there aren't very many patents on Diesel engines any more.

Mr. ARNOLD. No; but is that out of the development stage at this time?

Mr. KETTERING. It is out of one kind of a development stage. You know, we just finished a Diesel development. I have been on that job for about 8 or 10 years, and that has been largely a technique of engineering rather than invention, to get the weight down from 120 pounds per horsepower to 10 or 12. That was engineering technique rather than invention.

Mr. ARNOLD. Are there important patents alive in the Diesel engines today which would be a substantial deterrent to a company who wasn't licensed?

Mr. KETTERING. I don't think so.

Mr. ARNOLD. So the Diesel engine is past that stage or else it never got into it.

Mr. KETTERING. Let me say this about the method by which a thing gets started. When Rudolph Diesel built the first Diesel engine, its only market was to take the place of steam engines in ships, so it was fashioned to take the place of the steam engine. It had to go in as a substitute. Then later on the automobile business came along and we tried to make Diesel engines to take the place of the gasoline engine, so it had to go in as a substitute in another place. Suppose we didn't have anything, we would say, let's design a Diesel engine like a Diesel engine would like to be made instead of making it go into a place where something else has been useful.

Naturally, there is very little patenting in that. It was coming on to the problem in a different way. Suppose we had no industrial usage for this, suppose we are thinking of this in the cold abstract, how would we make the engine?

Mr. Arnold, you asked the question that is one of the greatest problems that the technical people have to deal with, and that is, we start down certain alleys, one fellow says this is the way to go, another that way, and another that way, and it is very difficult to get them to accept another fellow's opinion about that because there isn't anything in any of these engines, I think—the only patentable

thing is the injector, and anybody could buy good injectors from anybody.

Senator KING. The rest is mechanical.

Mr. KETTERING. The rest is engineering; yes. Of course, some of these new materials that have come along have helped that. I give the metallurgist quite a lot of credit for it.

Mr. OLIPHANT. I should like to ask this question in response to Senator King. You spoke very highly of the patent law as a stimulant to such development as we have had. Do you look upon the development in contemporary medicine as advanced and commendable?

Mr. KETTERING. Of course they have had a very difficult problem. You see, the medical fraternity is just now beginning to use the physicist and chemist, etc. It hasn't been the doctor's fault. That has been because we haven't had our organic chemistry and that side developed up to the point where they could really understand these things, and I think you will see perfectly enormous progress made in organic chemistry and biological chemistry in medicine in the next 20 years. You will see as great a development in chemistry in medicine and agriculture in the next 50 years as you have seen in the last 50 years in the so-called mechanical and electrical arts. It is a perfectly unexplored field.

Mr. OLIPHANT. The turn which your response to my question took suggests my altering my question somewhat and instead of asking you about applied medicine, ask you about the sciences constituting the immediate underpinning of modern scientific medicine. I refer to chemistry, physiology, biology, and so forth. We have had a large development in those fields, haven't we, since 1870?

Mr. KETTERING. I know, it has been large, but it is only small compared to the possibility, you see.

Mr. OLIPHANT. Would it have been larger if we had a system of patents applicable to the whole field?

Mr. KETTERING. I don't know. I can't tell you about that. If I may give one of my personal experiences, I have been running at Antioch College for quite a number of years this research on, we say, why the grass is green, how does the plant fix the sun's energy into chemical compounds. That has been worked on for a hundred years. I worked on it 25 years ago and couldn't get good people and tried it over again, so for the last 8 or 10 years we have had an organized staff working on it. We have made one new chemical compound there from which there can be at least half a million derivatives made. It is just like getting into a new continent. The interesting thing about those compounds is that every one of them comes from a light-sensitive base, a base which is affected by light. What the significance of that is going to be for medicine we haven't the slightest idea, but we are just learning how to do this biological chemistry now.

Mr. OLIPHANT. Did the patent incentive play an important part in that research at Antioch College?

Mr. KETTERING. Not a thing, no, not a thing. We felt that was so important to know. The only way we keep the sun's energy down here is to evaporate water to run down the rivers, or plant growth, and we don't know anything about how that plant is able to hold

the sun's energy there, and I felt for the general benefit of everybody we ought to know it. That is too sacred a thing to think of getting a patent on it. That is one of the things we ought to know because we ought to know it.

Senator KING. You had to have an institution that was endowed and persons who had some outside employment in order to continue those experiments.

Mr. KETTERING. Yes, indeed.

Mr. OLIPHANT. There is one statement you made which surprised me a good deal. That was in connection with your being ashamed of the state of the development of our technology because of our inability to utilize all this rich material and all this labor, and so forth. Do you look upon patent law as an incentive for providing more ideas, one of the bottle necks we have got to get through in order to utilize these materials and these men? Is that where the shortage is? Is that where the shoe is pinching?

Mr. KETTERING. I can only give you my opinion.

Mr. OLIPHANT. I would like very much to have your opinion.

Mr. KETTERING. It may not be worth a nickel, but I can tell you what it is. In the early stages of industry, and so forth, the things are obvious; in other words, the inventions are obvious. Now as you go along and get more technical, the doctor today has to know something about biology, something about physics, and something about chemistry. We are just in the transition point between what I might say is the individual invention and the group invention, and business doesn't understand how to do this yet, we don't understand as inventors how to do it, so we are in that transition stage of going from one phase to another, but I don't know whether we are learning as fast as we should. We are doing the best we can, but I am not very proud of how far we have gone.

Mr. OLIPHANT. Being in that sort of transition stage, wouldn't it suggest the wisdom of reexamining the postulates upon which our patent laws were framed a hundred years ago?

Mr. KETTERING. I doubt whether it is a patent thing that is involved in this so much. I can tell you what I think it is. You see, business, all businesses if they are any good have got to have very, very detailed cost accounts. That is the only way they can tell anything about it. When you come to this group invention work like we are doing, running a research laboratory, that doesn't fit into this detailed cost accounting. It is more an actuarial cost accounting like the insurance company runs.

Well, it is very hard to get accountants and auditors to understand that 99.9 percent of their business is audited on the basis of detailed cost, and then you can't tell how much this thing is going to cost when you get it done or whether it is going to be worth anything when you get it, that tends to make the research fellows take very specific small problems, but we are just learning now how to put actuarial accounting into this thing, so we say our research laboratory is not a scientific institution at all, it is an insurance company, and whatever you pay for operating it is the premium you pay for operating that, and all we insure you against is that we will keep you up to date technically. That is what you get for the policy. You can't blame the accountants, but when the fellow is doing 99.9 percent of

the work on detail he says, "Why can't this strange bunch of fellows over here give you some detail about their work?"

We are just learning how to introduce this question of research and development into industry and the accounting processes have been one of the most difficult things to get ironed out. We are just getting to understand that now. You see, we musn't forget that regardless of patents and inventions, we are still all human beings, and we still have those human problems to work with as a part of the first thing.

The CHAIRMAN. Mr. Ferguson, do you care to ask any questions?

Mr. FERGUSON. No.

The CHAIRMAN. Dr. Lubin?

Dr. LUBIN. No.

The CHAIRMAN. Mr. Kettering, you describe an inventor as a person with a special aptitude, interested not so much in the exploitation of his ideas as in the development of the ideas and thereby making a contribution to society.

Mr. KETTERING. I don't know whether he goes that far or not, whether he thinks about the contribution to society.

The CHAIRMAN. He makes a contribution to his own sense of self-satisfaction.

Mr. KETTERING. He is a sort of self-entertainer in a good many cases.

The CHAIRMAN. Accepting that definition, based upon your experience as the head of a research laboratory, would you care to say which factor derives the greatest amount of benefit from an invention as now patented; number one, the inventor; number two, the exploiter or the manufacturer; number three, the public?

Mr. KETTERING. Well, of course, if the public doesn't profit by it neither one of the other two will. It has to be something that, when you get it, you don't care whether there is a patent on it or not, if it serves your purpose and is at the right price, and it does you some good.

The difference we meet in why inventors work on things is a thing we meet in this transition thing. My main job in running the research laboratory is to pick the problem. Going back to the insurance analogy again, it is not a very good insurance company if it picks bum risks, but if it picks good risks it is. We can do more with the scientific man in our laboratory if we can take a problem and then subdivide it and say this is a metallurgical problem or a mechanical problem, or this, that, or the other thing. We can help those fellows to select the kind of things upon which they can work so there will be a high utility value at the end of them.

The CHAIRMAN. Returning to my question, it must be assumed that to be successfully used the patent must be beneficial to the public. There must be a public demand. Assuming that, which of the other two factors under the present system derive, in your opinion, the greater benefit—the inventor or the exploiter?

Mr. KETTERING. Well, I don't know. I don't know much about that.

The CHAIRMAN. Is it or is it not true that particularly in the automotive industry there have been several instances of the original inventors who derived practically little benefit. I have in mind—I may not be right about it—having read some years ago that a man who gave his name to a widely used automobile died in complete poverty.

Mr. KETTERING. He wasn't an inventor; he was a promoter.

The CHAIRMAN. You know the man I had in mind?

Mr. KETTERING. Dave Buick I think you were talking about. He was not an inventor in the sense I think of today. Of course—remember inventors have the same kind of peculiar personalities, sometimes, and they don't get along very well with other people, too, so you have that to take into consideration.

The CHAIRMAN. As you said a while ago, we are all human.

Mr. KETTERING. That's right.

The CHAIRMAN. How long did you say you have been at the head of the research bureau?

Mr. KETTERING. I think we organized the present consolidation in about 1920.

The CHAIRMAN. Research bureaus in large industries are a characteristic of modern corporate development, are they not?

Mr. KETTERING. It is the only way to do it. I don't know how to do it any other way. Take this Diesel engine problem we were telling you about. If you hadn't—

The CHAIRMAN (interposing). I didn't say it shouldn't be done.

Mr. KETTERING. Certain types of problems you can only do in that way because of the facilities. Take the metallurgical requirements and things like that.

The CHAIRMAN. I was impressed by your statement that we are passing into the era of group action.

Mr. KETTERING. That is right. We have to, in a lot of these problems. We have to do it with a group.

The CHAIRMAN. So that these research bureaus, of which you are the head of one, are characteristic of that era, are they not?

Mr. KETTERING. Of course, I still think every time they develop anything new they reopen a lot of new problems for the individuals outside.

The CHAIRMAN. The individual inventor whom you described, and you yourself, as indicated by your testimony, seems to be a person who is more interested in developing the idea than in almost anything else.

Mr. KETTERING. Yes, sir; getting it to work.

The CHAIRMAN. Do you think that Congress should give any research itself to the problem of making a better distribution of the ideas which are developed by inventors than we have now?

Mr. KETTERING. I wouldn't know how to answer that. I should think it would be a fine thing, for instance, if any of you are out around Detroit, to come in and see how these laboratories have to be run. I think that would be very, very good for Congress and it would be good for us, because, you see, we use the same language but we don't speak the same, because we have to work with a technical problem, and when we say the same words it doesn't mean the same to you unless you have the same thing to do.

Senator BORAH. Have you a bunch of cars here? We will drive out and see you.

Mr. KETTERING. We can get them, sir. I am really serious.

Senator BORAH. I am, too.

Mr. KETTERING. You fellows are trying to do the same thing we are trying to do, and if we could see each other's point of view and how we have to work, there is a good common meeting ground on all this stuff, and I think these hearings you have here are wonder-

ful, because a poor fellow like me wouldn't get to meet you gentlemen if it wasn't for something like this.

The CHAIRMAN. We wouldn't get to meet you. I think we profit more in the exchange.

With respect to your research bureau, Mr. Kettering, in searching for the answer to a particular problem, doubtless your research attendants frequently run across matters which are totally unrelated to the objective of the research.

Mr. KETTERING. Yes, sir.

The CHAIRMAN. And sometimes develop patentable ideas with respect to those independent things. What is the policy of your company with respect to such inventions?

Mr. KETTERING. They come under the regular patent contract.

The CHAIRMAN. So that if one of your employees were to invent a device which was altogether foreign to the automotive industry—

Mr. KETTERING (interposing). I don't know. What is our policy on that, Mr. McEvoy? The Senator asks the question, Supposing in developing a thing one of our men runs across something that has no relationship to the automobile industry, its utility value is clear outside of the field of the automobile? We let them have it.

Mr. McEVOY. Oh, yes.

The CHAIRMAN. You don't require that patent to be assigned to your company?

Mr. McEVOY. It would have to be something in connection with our work.

The CHAIRMAN. Your arrangement is that they must turn over to you only those patents which are usable in the automotive field.

Mr. McEVOY. That is right. Of course, we have a good many fields, sir.

The CHAIRMAN. In any field in which General Motors is interested.

Mr. McEVOY. That is the same thing; yes.

The CHAIRMAN. In conclusion, Mr. Kettering, so far as I am concerned, like Mr. Oliphant I was very much impressed by your very succinct and lucid statement that we have men out of work and money out of work and material out of work, and that the problem before the country is to get all three of these factors working together again.

Mr. KETTERING. That's right.

The CHAIRMAN. Have you any suggestions with respect to that, outside of the particular field in which you are interested?

Mr. KETTERING. I am doing the best I can in my field to get new ideas and new things going. We have this new Diesel business which is started. We are getting it on the railroads, and things like that.

The CHAIRMAN. And we are doing the best in our field, but your answer suggests to my mind that I ask you, if you received a larger allotment of funds from your accounting department, do you think you could accomplish more?

Mr. KETTERING. That isn't our trouble. The trouble is to get the problem so it is understood between management and industry and Government and everything else, what are the best problems to do? If we could have an inventions congress or conference here in which we had business men and economists and representatives of the Gov-

ernment, and could sit down and say, "Now, what are the most probable things that we can do?" Remember, some of the most important things to do you can't do in a hurry. It takes a long while. We have had men on work for 15 years, on some problems, and we haven't the solution to the thing yet.

The CHAIRMAN. May I say to you, taking advantage of your statement just now, that so far as I am concerned, the principal purpose of these hearings is to provide a forum for just such a conference with respect to our national economy. May I say to you, Mr. Kettering, that I feel very much stimulated by your testimony this afternoon, and I very much appreciate it.

Representative SUMNERS. Mr. Chairman, I am going to take advantage of this particular situation to make an observation that I believe is important for the country. You gentlemen who are here, engineers and inventors and so forth, in your work, undertake to discover how you may improve the machinery that you have to deal with. You discover natural law and how you can work in accord with it. And you are all co-partners with this Government. You own your business, but you also are part of this Government.

Those of us who are working at this job recognize that in the economic and political government we have difficulties. This government has a nature just like the things you work with. It has the economic government; it has a nature. It has a respiratory system, and I think a good many of us here at the Capital appreciate the fact that the time has come, if we are to preserve free government in this country, that we have got to discover the natural laws which govern governments, and how we can work in accord with them, and if we cannot preserve this Government, all these big fortunes that are being built up and all these mechanical developments will be a mockery to these people.

I much appreciate the observation of the chairman, and I believe I share with my colleagues on this committee the purpose to take advantage of this opportunity to see if we can discover what is fundamentally wrong, what may be done fundamentally to improve the economic and political organizations of the country.

We have been, I am afraid, a little different in government from what you and the doctors have been. Doctors will try out a new idea on a guinea pig first and they will be pretty cautious. Of course, we are not; but there have been people connected with government who want to try the whole idea on the Government first and then, if it won't work, they won't try it on the guinea pig, and they expect to have a diploma because it didn't make the guinea pig sick.

I am not attempting to make any general statement except that observation, and I address it to the people of this country. I take advantage, with the consent of my chairman, to make that brief observation to these people and to the country.

Mr. KETTERING. What you say is very true. How to do an experiment without building the whole machine has been one of the biggest problems we have had; how to discover how an engine worked by making only one cylinder of it. You must be patient, because we must learn how to set up a one cylinder government and try that out. I don't know anything about it.

Representative SUMNERS. This is a pretty good machine, a pretty fair machine, and it isn't true that just because a thing has stood the test for 25 years it should be destroyed.

Mr. KETTERING. I don't think we technicians can help you on that, more than to show you how we tackle our problems, and you fellows, if you take that, maybe can get something out of it. I don't know how it would apply to your problem. We will be very happy to assist in any way we could. We will tell you how we go about our problems and things like that, and if there is anything that is usable, we will be very happy to have you use it.

Senator KING. If this is a testimony meeting, isn't it a fact that democratic government, and in that phrase I mean a democratic government in all of the proper connotations, is the most difficult to maintain in the midst of communism, socialism, and dictatorship? It is one of the most fragile of all governments and requires intelligence and patriotism and a high degree of reverence for the spiritual and moral values of life. If we have those things, this democracy will survive. If not, it won't.

Mr. KETTERING. You are right.

The CHAIRMAN. Mr. Cox, do you have anything to add at this moment?

Mr. Cox. No, sir.

The CHAIRMAN. Mr. Kettering, we are very much indebted to you and you are now excused.

(The witness was excused.)

Mr. Cox. We wish to recall Mr. McEvoy for a short time, and with the chairman's permission I am going to ask Mr. Dession to examine him.

The CHAIRMAN. Mr. Dession, you may examine Mr. McEvoy.

TESTIMONY OF JAMES McEVROY, PATENT COUNSEL, GENERAL MOTORS CORPORATION, DETROIT, MICH.—Resumed

Mr. DESSION. I think you testified this morning, Mr. McEvoy, that you are director of the patent section of the General Motors Corporation.

Mr. McEVROY. Yes, sir.

Mr. DESSION. How long have you occupied that position?

Mr. McEVROY. Since July, 1922.

Mr. DESSION. And were you before that time connected with the corporation?

Mr. McEVROY. Yes; I had charge of the legal department in Detroit.

Mr. DESSION. From about 1920?

Mr. McEVROY. It was from 1921. Before that I was general counsel of the corporation in New York.

Mr. DESSION. In your capacity as director of the patent section, I assume that you formulate and administer the patent policies of the corporation?

Mr. McEVROY. Yes, sir.

Mr. DESSION. I show you a pamphlet which reads "General Motors Corporation Procedure Covering Patent Section Activities." Does this embody the general system adopted by the corporation?

Mr. McEVOY. Yes; it does.

Mr. DESSION. We offer that.

The CHAIRMAN. Do you desire to have it included in the record.

Mr. DESSION. It need not be printed.

The CHAIRMAN. It may be marked.

(The pamphlet referred to was marked "Exhibit No. 102" and is on file with the committee.)

Mr. DESSION. And is this the corresponding memorandum of procedure on foreign patents and engineering accomplishments?

Mr. McEVOY. It is.

Mr. DESSION. We offer that as an accompanying exhibit.

(The pamphlet referred to was marked "Exhibit No. 103" and is on file with the committee.)

Mr. DESSION. That would place your entry into the corporation at about the middle of the period covering the first cross-licensing agreement, would it not?

Mr. McEVOY. Yes.

Mr. DESSION. That is, the agreement was adopted in 1915 and expired in 1925.

Mr. McEVOY. Yes.

Mr. DESSION. At that time, Mr. McEvoY, and in your capacity as director of the patent section, did you gather any impressions as to why the General Motors Corporation, and perhaps others, were induced to enter that cross-licensing agreement?

Mr. McEVOY. Well, I didn't know anything about the cross-licensing agreement until early in 1923, I guess. I began to attempt to analyze it, to see what it might mean to the corporation if we entered into a renewal of it. I was told that in the early days of the industry, in 1915, all of the automobile companies that became members of the chamber thought that a cross-licensing agreement, under which each of them could use the others' patents, would be an exceedingly valuable thing, and perhaps it was at that time. I don't know.

Mr. DESSION. Was that primarily because it would clear the decks—facilitate design?

Mr. McEVOY. I don't really know what was in the mind—I think most of them were sort of terrified by that old Selden case and just thought it would be a good thing to do.

Mr. DESSION. Do you think the Kardo Corporation, that is the formation of that corporation around 1914, was another factor?

Mr. McEVOY. In the cross-licensing?

Mr. DESSION. Yes.

Mr. McEVOY. I don't know.

Mr. DESSION. When you re-examined the patent situation as of 1923, did you find there were important patents owned by other companies which General Motors needed to use?

Mr. McEVOY. There were no important patents whatever.

Mr. DESSION. Were there any patents which you were using?

Mr. McEVOY. Yes.

Mr. DESSION. Would it have involved considerable trouble or expense to redesign so that you might avoid them?

Mr. McEVOY. Not a great deal; no. We were using at that time 22 patents going to the other members of the cross-licensing agreement, and they were using 42 of ours. None of them was controlling

in any sense. There were two patents that we didn't want to continue using. We could have gotten away from them by changing our structure a little, that was all.

Mr. DESSION. During that period, Mr. McEvoy, did General Motors ever claim that it held any patent which was entirely apart from the agreement, a class B patent?

Mr. McEvoy. No, sir.

Mr. DESSION. I mean by class B a patent of exceptional originality.

Mr. McEvoy. We never had any such patent.

Mr. DESSION. And General Motors joined in all the subsequent extensions of the cross-license agreement, did it not?

Mr. McEvoy. Yes.

Mr. DESSION. And was there any particular reason for that?

Mr. McEvoy. You mean for their doing it?

Mr. DESSION. Yes.

Mr. McEvoy. No. The only reason was that I think all of the automobile companies other than Ford Co. felt that this chamber, or the present Manufacturers Association, was a very good thing, mainly because the men got together and talked over problems, and all that sort of thing. I think that was the main notion, not so far as the patents were concerned, not after 1925.

Mr. DESSION. Referring back to the period just before 1925, I show you what purports to be a report on the cross-license prepared for you by a member of your department, and if you will look at page 4, and also at page 6, it is stated there are certain Maxwell and other patents not necessarily controlling but which it would be advisable to own?

Mr. McEvoy. Yes; there was one patent owned by the Maxwell Co., known as the Law transmission patent. That covered a certain feature of transmission that I think all the automobile companies were using at that time. So when I had this report made, I was uncertain whether we would join in the renewal of the cross-license agreement or not. I saw the Maxwell Co. and took a license under that patent. Didn't pay them anything for it, they didn't ask for anything, and then there was another patent that covered a banjo type of axle that was being used on one or two of our cars and we did nothing about that because we intended to give that up in a short time. Those are the only two patents that were of the slightest importance at that time.

Mr. DESSION. Now, coming up to the present day, Mr. McEvoy, would you say that General Motors had any general policy with respect to taking out or acquiring patents?

Mr. McEvoy. Well, I don't know that we have any definite general policy in regard to taking out patents.

Mr. DESSION. Let me put it another way. Is there any dominant purpose which you have in mind which guides you as to whether or not you will try to buy or take out an application on a given invention?

Mr. McEvoy. Probably the main reason why we filed so many applications was because if you didn't do that there might be some application in the Patent Office covering the same idea, and then the patent would be issued and we would be charged with infringement.

We have had in the Detroit office alone since 1922 about 750 interference proceedings.

Mr. DESSION. And in these interferences have you found that patents taken out by the corporation have been of substantial value purely as protection against those interferences?

Mr. McEvoy. Yes.

Mr. DESSION. So that I assume that many of the patents taken out on work or developed by the employees may have had considerable utility in that connection.

Mr. McEvoy. A good many of them have.

Mr. DESSION. Even though you might not desire to use them in any other way?

Mr. McEvoy. Yes. Of course you can't tell about using an application that is filed how it may appear at the time that we are going to use it. Maybe we do use it, and perhaps by the time the patent is granted we have given it up with a change in the structure.

Mr. DESSION. I have here a memorandum which is entitled "Reasons for taking out or acquiring patents" also. Is that by General Motors?

Mr. McEvoy. Yes; I prepared that.

Mr. DESSION. I offer that as an exhibit.

The CHAIRMAN. It may be marked.

(The memorandum referred to was marked "Exhibit No. 104" and is included in the appendix on p. 691.)

Mr. DESSION. You stated, Mr. McEvoy, that you have had some 446 interferences against General Motors since 1922; and I suppose the total, if you lumped in the other divisions of General Motors, would be larger.

Mr. McEvoy. Oh, yes.

Mr. DESSION. Could you estimate the total at all?

Mr. McEvoy. I can give it to you in a minute.

Mr. DESSION. I will withdraw that question. Never mind the exact number.

Mr. McEvoy. I can dig it out for you.

Mr. DESSION. I think we can dispense with the number.

Mr. McEvoy. I should say in the neighborhood of perhaps 800.

Mr. DESSION. Is the corporation very frequently charged with infringement of other patents?

Mr. McEvoy. Yes; quite often.

Mr. DESSION. Could you give us any idea of the number of such notices over any given year?

Mr. McEvoy. Yes. We have three main offices, the Detroit patent office and one at the Frigidaire in Dayton and the Delco Products division factory. At the Detroit office during the years 1927 to 1937, inclusive, we had 660 charges of infringement.

Mr. DESSION. What came of those?

Mr. McEvoy. We never heard any more from most of them.

Mr. DESSION. Did some of those result in settlements or suits?

Mr. McEvoy. We had some suits; I couldn't tell you just how many suits were brought.

Mr. DESSION. Will you look at this memorandum?

(The memorandum referred to was marked "Exhibit No. 105" and is included in the appendix on p. 697.)

Mr. McEvoy. Very often suit is brought without infringement notice. We have had altogether 99 suits brought against the corporation since its inception.

Mr. DESSION. Most of those, I believe, are from charges of infringement.

Mr. McEvoy. Some were not. Sometimes a suit was brought without any charge of infringement.

Senator KING. What were they brought for, if I may inquire.

Mr. McEvoy. For infringement, but you don't have to give a notice. Sometimes they don't do that—just file the bill.

Mr. DESSION. That is 99 suits since 1914?

Mr. McEvoy. Yes, sir.

Mr. DESSION. And how many suits, if you know, did General Motors bring against other persons?

Mr. McEvoy. Twenty-five, I think.

Mr. DESSION. And did all of these go to trial?

Mr. McEvoy. Oh, no.

Mr. DESSION. Were most of them settled?

Mr. McEvoy. Of the suits brought against the corporation we lost 9; that is, 9 were decided against us. Twenty we won, and 20 were settled before trial or shortly after, and 35 were discontinued with the plaintiff before trial and were stricken from the calendar under rule 57. In none of those cases did we pay anything, make any settlement, and there are 15 cases now pending.

Senator KING. You differentiated between your Delco and your other activities outside of the automobile industry. Were any of those suits or interferences based on the Delco?

Mr. McEvoy. Oh, yes; these are all of the suits. This statement I have given is of all of the suits, including Frigidaire and everything else.

Senator KING. What I am trying to get at is how many of those suits were based upon alleged infringement of patents dealing especially with automobiles or the automobile industry. I am not speaking about Delco's, Frigidaire, or any of those other activities in which your company is engaged.

Mr. McEvoy. Sixty-two, sir. Sixty-two dealt with the automobile or things connected with it such as carburetor and so on.

Mr. DESSION. That is out of a total of 99?

Mr. McEvoy. Yes, sir.

Mr. DESSION. Now, I show you a schedule of costs of litigation by years. Was that prepared in your office?

Mr. McEvoy. Yes; I prepared that.

Mr. DESSION. Will you tell us what it was for the last year indicated?

Mr. McEvoy. For 1937?

Mr. DESSION. Yes.

Mr. McEvoy. It was \$262,711.74.

Senator KING. Did that include any judgments?

Mr. McEvoy. No; just legal expense.

Mr. DESSION. Lawyers' fees and tests and so on. And, as indicated by the schedule, that was not an unusual figure as a yearly average?

Mr. McEvoy. No.

Mr. DESSION. I offer that as an exhibit.

The CHAIRMAN. It may be accepted.

(The schedule referred to was marked "Exhibit No. 106" and is included in the appendix on p. 700.)

The CHAIRMAN. In the interest of expediting the hearing, if you have very many more exhibits I am sure that it might be possible just to present them by reading without going to the bother of having each one identified, unless there is some objection on the part of the witness.

Mr. DESSION. We have a few more and we will follow that procedure.

Now I should like to refer to the policy of General Motors insofar as licensing competitors is concerned under its own patents. Do you have any recollection of an instance where a license was refused to any competitor?

Mr. McEvoy. No, sir. We have never refused to grant a license.

Mr. DESSION. Do you differentiate in licensing between inventions of what you would regard as exceptional value to the corporation and the general run of patents?

Mr. McEvoy. No.

Mr. DESSION. Let me take an example. Did General Motors a few years ago acquire a patent on the Thompson synchro-mesh transmission?

Mr. McEvoy. Yes.

Mr. DESSION. Would you regard that as one of the more valuable patents now?

Mr. McEvoy. No.

Mr. DESSION. Do you recall roughly what General Motors paid for that patent?

Mr. McEvoy. I think we paid Thompson something over \$500,000. Then we had to buy three or four other patents. We found we were in conflict with it and I suppose that the actual patent cost was nearly \$600,000, and then the development cost was probably a million.

Mr. DESSION. Was a license under that patent or those patents granted to Packard?

Mr. McEvoy. Yes.

Mr. DESSION. Do you recall what sort of terms Packard paid under that agreement?

Mr. McEvoy. Yes; the original arrangement was \$1.25 a car, with a provision that when \$200,000 was paid the license would be paid up. For that we gave Packard a good deal more than just the license, because we gave Packard all the production drawings of the Cadillac car, and then they continued to pay that royalty until they paid, I think, \$66,000, and then they put out a small car which hadn't been contemplated at the time the license was taken. It didn't seem fair to charge them as much as \$1.25 on the small car, so we made an arrangement with them whereby the license was canceled, and two or three other controversies we had with them at that time were wiped out, so we really got \$66,000.

Mr. DESSION. And with respect to those same patents, did any other automobile manufacturers use that synchro-mesh?

Mr. McEvoy. Yes; all of them did, because the transmission is made by the Borg-Warner Motor Co. and sold to almost every automobile company in the country.

Mr. DESSION. And did General Motors license Borg-Warner?

Mr. McEvoy. Yes.

Mr. DESSION. Was that before or after they started making and selling these transmissions?

Mr. McEvoy. Several years after.

Mr. DESSION. And was that suit settled or did it go to final determination?

Mr. McEvoy. No; it was settled.

Mr. DESSION. What sort of terms did General Motors accept in that instance?

Mr. McEvoy. They paid \$75,000 and gave us the license under a number of patents they had on ready transmission.

Mr. DESSION. Let me examine one other instance. Would the Fisher ventilation system be regarded by you as another especially valuable General Motors patent?

Mr. McEvoy. Yes; we hold that very valuable.

Mr. DESSION. Was that patent ever a matter of interest to the Ford Motor Co.?

Mr. McEvoy. Yes; just a few months ago they talked about using it and taking a license.

Mr. DESSION. And was there any discussion of terms in connection with that?

Mr. McEvoy. No; we didn't get that far because they decided they wouldn't change this year.

Mr. DESSION. And you wouldn't venture to suggest the sort of terms that might have been suggested by General Motors?

Mr. McEvoy. No.

Mr. DESSION. General Motors would have required some payment.

Mr. McEvoy. Oh, yes. Not very much, however.

Mr. DESSION. I show you a schedule of royalties paid to General Motors, and royalties collected by General Motors, which runs from 1924 through the end of 1937.

(The schedule referred to was marked "Exhibit No. 107" and is on file with the committee. A similar schedule for 1937 was marked "Exhibit No. 107-A" and is on file with the committee.)

Mr. DESSION. That shows, does it not, the grand total for the period of some three and a half million in royalties collected, and some slightly under 14 million in royalties paid?

Mr. McEvoy. That is correct, except that ought to be "Royalties and purchase of patents." That is an error because it says simply "Royalties."

Mr. DESSION. So the item of "Royalties paid" includes patents purchased?

Mr. McEvoy. That is right.

Senator KING. That is to say, your company purchased a number of patents.

Mr. McEvoy. Yes, sir.

Senator KING. And paid a royalty upon others?

Mr. McEvoy. Yes, sir.

Mr. DESSION. Could you state offhand, Mr. McEvoy, about what the net royalty cost to General Motors would represent per automobile produced?

Mr. McEvoy. Of course, that varies from year to year, but certainly never more than 50 cents.

Mr. DESSION. And at the present time do you think it would be less than that?

Mr. McEvoy. I think it would, probably not more than 35 or 40 cents.

Mr. DESSION. And do you think that amount might be much larger if the attitude which we have heard described here with respect to patents in the auto industry had been different?

Mr. McEvoy. I don't think so.

Mr. DESSION. I realize that the question is speculative, but you aren't sure that it would make any material difference.

Mr. McEvoy. I don't think it would.

Mr. ARNOLD. You don't think you collect every cent you possibly could?

Mr. McEvoy. We never tried to do that. As Mr. Knudsen said, we are making automobiles and not exploiting patents.

Mr. ARNOLD. I think that is what the question was directed at.

Representative SUMNERS. When you turned in your patents to the pool, there were two which you regarded as of some value. Did you make some statement to that effect?

Mr. McEvoy. No, sir.

Representative SUMNERS. I misunderstood you.

Mr. McEvoy. I said when the first cross-licensing agreement came to an end, there were two patents, one belonging to the Maxwell Co. and one belonging to another company, that we were using and wanted to continue to use for a short time, but they weren't of any special value. We wanted them just because we were using a particular form of axle.

Representative SUMNERS. Those were two that you got out of the pool?

Mr. McEvoy. Yes.

Representative SUMNERS. How many were you using still that you contributed to the pool, of your own?

Mr. McEvoy. We were using 22 patents, I think it was, altogether.

Representative SUMNERS. Thank you very much, and I hope you will pardon that interruption.

Mr. DESSION. Mr. McEvoy, when licenses have been issued by General Motors has there ever been a license with any provision in it restricting the licensee either as to the movement of a given product that he might produce, or as to the region wherein he might market it?

Mr. McEvoy. No, indeed.

Mr. DESSION. Has there ever been any restriction as to resale price?

Mr. McEvoy. No, sir.

Mr. DESSION. Have you ever granted any exclusive licenses?

Mr. McEvoy. No, sir.

Mr. DESSION. That has not been the practice?

Mr. McEvoy. No; and it is not our practice to use those exclusive patents either.

Mr. DESSION. Would you refuse one if it were offered you?

Mr. McEvoy. I don't know. An exclusive license is a much more expensive thing than a nonexclusive one. We have taken only a very few exclusive licenses, and in most cases because we had a very great

deal of development work to do. In one or two cases we wanted the license rather badly and the licensor insisted on the exclusive license.

Mr. DESSION. You may have heard this morning, and perhaps yesterday, Mr. McEvoy, some discussion here as to whether there was any tendency under the present patent laws and the patent system for patents to issue on a great many trivial details, as well as on inventions of genuine importance.

Mr. McEvoy. Oh, yes.

Mr. DESSION. Do you concur in the impression that there are too many detailed patents?

Mr. McEvoy. There is no question about that.

Mr. DESSION. I have here four metal screws, Mr. McEvoy. I wonder if you would look at these and tell us what essential difference, if any, there is between them.

Mr. McEvoy. I can't see any.

Mr. DESSION. If there are no essential differences, are there any differences at all?

Mr. McEvoy. I can see nothing substantial. This is rather interesting. I presented these, in talking over the thing and seeing the troubles that you were up against in the Patent Office in issuing a perfectly silly patent.

Mr. DESSION. Now, two of those screws have a crossed slot, that is to say, two slots like a cross in the head, and the others have one; is that right?

Mr. McEvoy. That is right.

Mr. DESSION. That is about the only difference?

Mr. McEvoy. That is all.

Senator KING. This isn't supposed to represent a Swastika, is it, with those indentations on top here?

Mr. McEvoy. Here is the collection of patents issued on that sort of thing. I think there are about 25 of them.

Senator KING. They get a patent, then, for the little indentation, the form of the indentation on the head of the screw?

Mr. McEvoy. Yes, sir; and there are thousands and thousands of patents just like that.

Senator KING. Would there be any patent issued upon the number of spiral descents?

Mr. McEvoy. Yes; we might do that, too.

Mr. DESSION. Those are all right-handed screws?

Mr. McEvoy. I imagine so. But it might be of some interest to the members of the committee to look at some of these patents.

Mr. DESSION. That is a collection of patents on the cross-slotted screw.

Mr. McEvoy. You will notice on the end of the screw that they are a little different, but all substantially the same.

Mr. DESSION. May we have those four metal screws marked as an exhibit, and also the collection on patents on the double-slotted head?

(The four metal screws referred to were marked "Exhibit No. 108" and are on file with the committee. The collection of patents referred to was marked "Exhibit No. 109" and is on file with the committee.)

Mr. DESSION. And you would say there are numerous other instances of similar patents issued?

Mr. McEvoy. Oh, yes.

The CHAIRMAN. Isn't the issuance of patents like this a result of the difficulty of putting into language a definition of what is new and useful?

Mr. McEvoy. I think one difficulty, sir, in the Patent Office is the pressure that they are under to get out patents. They are supposed to get out so many thousand patents every year, and in many cases there is no proper investigation, sometimes no investigation whatever.

Mr. ARNOLD. The pressure seems to operate to get out more patents rather than to neglect them and get out fewer ones?

Mr. McEvoy. That is right, and I understand in a great many divisions the head of the division has given orders to the men that they have to get out so many patents every week, and so there are so many of them it is impossible for them even to read the claims.

Senator KING. May I ask this question: Does the law require, where there is such a similarity as this little indentation in the top of the screw, that a person shall have a patent for each one of those?

Mr. McEvoy. There is nothing in the law whatever, sir. It is a matter of opinion of the examiner whether you have an invention or not.

Senator KING. The law doesn't clearly define what an invention is, then?

Mr. McEvoy. No, sir; and there are a good many decisions on that. The Supreme Court has handed down various decisions defining invention in very good shape, but this is another pressure the Patent Office is up against, a very wide difference of opinion among the various circuits. You find one circuit will hold one way on something and another circuit another way.

Senator KING. The industry then might take out a patent on a screw where it was desired to have a little different type of die at the top than those in use, for fear that somebody else, if he adopted that form of screw, might seek a patent for it.

Mr. McEvoy. That is right.

Senator KING. So people might feel constrained to ask for a patent upon a matter that was very simple and apparently not worthy of patent.

Mr. McEvoy. Yes; and some of these men are very ingenious in doing that very thing. Of course, I think that most patents like that are utterly invalid. I don't think they would be upheld by any court, but that is something nobody can tell.

Senator KING. Somebody might sue the company and make some trouble anyway.

Mr. McEvoy. Yes, sir; very serious trouble.

Mr. DESSION. Are those slotted screws used in making automobile bodies?

Mr. McEvoy. Yes.

Mr. DESSION. Do you know whether they cost substantially more than the one-slotted screw?

Mr. McEvoy. No; I am quite sure they don't.

Mr. DESSION. If I suggested to you that in Washington you could buy the one-slotted screw in any 5-and-10-cent store at about 12 for a nickel, and the 2-slotted ones would cost about 3 cents, would you be surprised at that?

Mr. McEvoy. No; I wouldn't be surprised.

Mr. DESSION. You don't know whether to attribute that difference in cost to the 18 patents?

Mr. McEvoy. They don't all belong to one man. I suppose they charge it because they can get it.

Mr. DESSION. There has been various testimony here today with respect to other comments and suggestions on the working of the patent laws and the patent system. Do you care to advance any comments of your own, or comment on the comments made?

Mr. McEvoy. There are two special things that I think should be corrected in our patent system. One is, you gentlemen probably know an application is filed and it is secret. Nobody knows anything about it until the patent is issued, unless you have in the file an application that goes in interference with it, and then of course you would know. In many cases those applications stay in the Patent Office for many years until a big industry is built up. For instance, take the Delco-Remy Co.; that is a very good illustration.

Mr. Kettering developed the self-starter in 1911, he started his work then, and then the Remy boys started their work on the two-unit. There are two sets: Mr. Kettering's was a single unit and the Remy Bros.' was a double unit, and both those large industries were built up with millions and millions of dollars invested. In 1920 five patents were issued to a man named Heaney that covered every phase of the starting and lighting system. Those patents had been held in the Patent Office for 15 years, and every year they were amended until they covered the entire situation. That has happened in thousands and thousands of cases.

I think that applications should be thrown open to the public for you to know what is in there.

The CHAIRMAN. What was the result of that condition?

Mr. McEvoy. The result was that they brought suits, the concern that owned those patents, and the General Motors Corporation, although they felt pretty sure the patents were invalid, considered it too big a risk to run, so we made a settlement and paid \$600,000 for the license.

Everything that goes into production in General Motors comes to my department and we make a patent search to see if we infringe on somebody's patent. We make several thousand investigations a year on every single item that goes into production.

Most of the licenses we take we find are as a result of researches, and we run into somebody's patent and then we buy the patent, but all we can do is to examine issued patents. We have no idea what is in the Patent Office, don't you see, in the way of applications.

You spoke about this Thompson transmission. Mr. Thompson brought his invention to us; he had one patent, and he had several applications. We made a search as best we could and we didn't find any issue of patents that conflicted with it, but we had to buy four patents to clear his situation, all of which were in the Patent Office in applications.

Senator KING. But you had no knowledge of that.

Mr. McEvoy. No, sir. I see no reason why an application shouldn't be thrown open—it is done in England, it is done in Germany, and in France—to the public so you can see what is in the Patent Office and what you have got to meet.

The CHAIRMAN. Would it be agreeable to you if I should interrupt the witness in order to ask a question of Commissioner Coe, who is sitting at the table, for my own information? Commissioner Coe, what is the practice within the Patent Office with respect to the examination of pending applications before a given patent is issued, that is to say, for the examination of pending applications for the purpose of developing possibilities of conflict?

**STATEMENT OF CONWAY P. COE, COMMISSIONER OF PATENTS,
UNITED STATES PATENT OFFICE, WASHINGTON, D. C.**

Mr. COE. Mr. Chairman, it gives me a great deal of pleasure to answer that question. In spite of the criticism that has been leveled at the Patent Office, I think I am safe in saying that we have the finest examination system of any major country in the world, and it is generally so regarded. It is the envy of every other country that I have talked to. Commissioners of Patents are striving to approach the efficiency of the United States Patent Office in its examination of cases. Our Patent Office is organized and is broken down into a number of divisions, each according to its several arts known to man. One section handles the art of typewriters, shoe machines, chemicals—examiners in that art devote themselves to particular subsections of the various general arts, and they are assigned cases to handle in that art until they become extremely expert.

Now, it is true that a great many so-called trivial patents are issued. Of course the gentlemen that refer to trivial patents that I have spoken to always regard those patents as patents of their competitors; they never file trivial patents. The fact is that the Patent Office receives more criticism because it is harsh and strict and refuses patents far more than it is generous in its grant. As one evidence of that fact, the Commissioner of Patents is the most sued of all Government officials. The United States marshal is a daily visitor to my office, bringing complaints against the illegality, the unfairness, the harshness of the Patent Office in refusing to grant patents. The further fact is that 40 percent of all cases filed are denied.

Another fact is that not one-tenth of 1 percent of patents are filed in the form sought by the inventor, and on these two patents, for example, the inventors probably claimed a great deal when they came into the Patent Office. This much is evident, that the protection afforded by those patents is extremely small.

I would be interested in knowing, for example, whether or not any of the automobile companies filed applications on any of those patents and whether they belonged to any of the companies, and whether the people who complain about trivial patents would be willing for the Patent Office to restrict their application to materially raise the standard of invention. It is a problem that we are faced with every day. We realize that we would like to elevate the standard of invention, but how can we do it unless the Patent Office is made a tribunal of final resort, which I don't think it should be. I think that Congress wisely provided that there should be some review from the administrative agencies of the Patent Office. On the other hand, as to the patents that we grant, only those patents are granted by the Patent Office which in our judgment our appellate courts would require us to grant, and we are reversed often

enough by the appellate courts to set a standard for the Patent Office. I don't know whether I have answered your question specifically or not.

The CHAIRMAN. I was asking you what your practice is to set up searches within the Patent Office so as to prevent such a situation as the witness has described, wherein after a particular patent had been issued, another patent which had been pending in application form at that time was later issued with the result that his company had to pay \$600,000 to acquire licenses.

Mr. COE. Mr. Chairman, I will answer that question in this way: Seldom if ever is a patent held invalid on the art known and considered by the Patent Office. Of course this matter of getting, collecting human knowledge is an extremely difficult thing to do. We do the best we can, and there are many things unknown to the Patent Office and generally when a patent is held invalid, it is in view of something not known to the Patent Office.

Now, the proposal which I would favor, of publishing applications for patents before the grant theoretically would improve that situation in that it would bring into the Patent Office art in which we have a knowledge that we now have no means of collecting. On the other hand, there are very serious objections to it. In its application in foreign countries, for example, one of the most serious is that large corporations invariably take advantage of the opposition proceedings to oppose the grant of a patent which in effect then becomes a small litigation as to whether or not the patent should be granted and the small inventor and small business cannot endure that expense.

The CHAIRMAN. You say that the Patent Office is frequently reversed by the courts. In what proportion of these cases is the reversal granted because of your issuing an invalid patent rather than your failing to issue a patent?

Mr. COE. Well, there are two separate courts that handle those two questions. One is the question of infringement and validity. It comes up only in infringement suits. The second is on an appeal from the Patent Office in its denial of a patent. Therefore, the action of the courts in those two respects cannot be very well prepared.

The CHAIRMAN. In actual number they could.

Mr. COE. The courts of the District of Columbia reverse the Patent Office in approximately 25 to 30 percent of the cases. Now, naturally the Patent Office will not get in a position where it receives more unfavorable opinions from above than favorable opinions. So it is quite natural that we win a majority of our cases; otherwise, we would naturally be sending up cases needlessly.

The CHAIRMAN. This 30 percent of the cases in the District of Columbia courts—are they cases chiefly in which you are required to issue patents which you are refused?

Mr. COE. Which the examiner has refused and which the Board of Appeals has failed to issue and which the applicants insist, in spite of that, that they have a valuable invention.

The CHAIRMAN. So the facts are the courts compel you to issue more patents than you would of your own volition.

Mr. COE. That is absolutely correct, and I further repeat my prior statement that the only way the Patent Office can elevate the standard of invention is to make the Patent Office a tribunal of final

resort so that we can set the standard. There is no use of our elevating the standard and have the court tell us it is too high.

The CHAIRMAN. Thank you very much, Mr. Commissioner.

Mr. ARNOLD. You said you didn't want that done.

Mr. COE. I think that Congress wisely provided a review of an administrative agency; yes.

Mr. ARNOLD. And yet you say the only way to improve it is to have that thing removed.

Mr. COE. No, sir; Mr. Arnold, I didn't say it was the only way we could improve it, because I am not sure that that is necessary.

Mr. ARNOLD. I misunderstood you. I thought you said the only way you could elevate the standards was to make you, your commission, a court of final resort, and at the same time you said you wouldn't want it done.

Mr. COE. Yes; but the question is whether or not it is desirable and necessary to raise the standard of invention.

The CHAIRMAN. When you use the phrase "elevate the standard" you are using that in a technical sense.

Mr. COE. I mean in response to the demand for fewer and better patents. Now, I have heard that phrase used, Mr. Chairman, and the Patent Office has received that precept many, many times, but we seem to be denied to give the prophecy required for its fulfillment. We don't seem to know just how to tell how important an invention may be at the time it is filed in the Patent Office.

Senator KING. Do you think that it would be an improvement upon the present patent system if as soon as an application for the patent is filed, whether you call it *lis pendens* or the application as set out in detail, it should be published or notice given on a board there, or the public advised as to the character and nature of the application which has been made? That was the point that the witness was calling attention to.

Mr. COE. As distinguished from the present practice, as far as the present practice is concerned, I would regard that as a substantial improvement, but I feel that if we would adopt a measure something like the 20-year bill and get cases out of the Patent Office, none of these things would be necessary.

The CHAIRMAN. Proceed, Mr. Dession.

Mr. DESSION. I have here a study, entitled "History of the Growth of the Long Pending Patent Application Evil." That was prepared by the General Motors patent section.

Mr. McEVoy. Yes; by Mr. Miller.

Mr. DESSION. We offer that for the record.

The CHAIRMAN. You want that in the record.

Mr. DESSION. Yes.

The CHAIRMAN. It may be marked.

(The document referred to was marked "Exhibit No. 110" and is included in the appendix on p. 701.)

Mr. DESSION. That contains, amongst other things, a study of the 143 particularly important patent applications?

Mr. McEVoy. Yes.

Mr. DESSION. And can you tell us in a general way what this study shows as to length of time?

Mr. McEVoy. It shows that many of these patents, applications rather, remained in the Patent Office sometimes as much as 5 years and 10 months.

Mr. DESSION. And does it show that ever since, is it 1884 that that study begins?

Mr. McEvoy. Yes.

Mr. DESSION. Ever since that year the average period of pendency for all patents has been steadily lengthening?

Mr. McEvoy. It was up to 1930. I think since the last few years it has gone down, since the office has been pushing these applications out a little faster. I don't want you to think I am criticizing the Patent Office, because I am not, for they have done an exceedingly good job.

Mr. DESSION. I should like the record to show that my question contains no such suggestion. This is a study of actual intervals, the causes, or something else, and those important patents picked out for particular study there include such patents as the Morse telegraph, the kinetoscope, the Edison motion-picture camera pending for 6 years, the Ricker auto ignition patent pending for 15 years and 9 months.

It was part of the Heaney group.

Mr. DESSION. I show you another paper entitled "Proposed Patent Legislation," and prepared by Mr. George H. Willitts and various other members of the Michigan Bar. Does that also represent the point of view of General Motors?

Mr. McEvoy. Yes.

(The paper referred to was marked "Exhibit No. 111" and is included in the appendix on p. 714.)

Mr. DESSION. I will offer that for the record.

The CHAIRMAN. It may be accepted.

Mr. DESSION. I have no further questions, Mr. Chairman.

The CHAIRMAN. Do any members of the committee desire to ask Mr. McEvoy any additional questions?

Representative REECE. As I understood, you advocated the opening up of the application to the public, or some procedure by which other parties would have a right to know about the application. Then also did you advocate that other parties should have a right to come in and protest the granting of a patent on an application?

Mr. McEvoy. They do that abroad. I hadn't thought about that very much. That isn't important to me.

Representative REECE. If that procedure should be adopted, then the examiner's office would have a tendency to develop into a trial board, would it not?

Mr. McEvoy. Yes.

Representative REECE. And in that case, how would a smaller man, an independent man, who had no means and lived a distance from the capital, be able to properly protect his rights as against the efforts of some large corporation which might be adversely affected by his application if the patent should be granted?

Mr. McEvoy. I think we have the same situation now in regard to interferences in the Patent Office. Of course there is a lot of talk about the poor inventor and that sort of thing. I don't just exactly hold to it.

Representative REECE. What is your attitude toward the interference proceedings?

Mr. McEvoy. I think that that is one thing that certainly ought to be corrected. The present interference proceeding is perfectly

dreadful. The troubled lawyer cannot straighten the thing out in 5, 6, 7, or 8 years.

Representative REECE. But at the present time you suggest the same thing be adopted with reference to applications?

Mr. McEvoy. I am not suggesting that at all. I am not prepared to say that it is a good idea to allow anyone who is affected by an application to file a protest as you do abroad. The thing I am interested in is throwing the application open after a reasonable time, say the end of the second year or 3 years, or something of that kind so that we know what is in the office.

Representative REECE. You think it would be advisable to have one court vested with power to hear all patent cases?

Mr. McEvoy. I think it would be a very good idea.

Representative REECE. Rather than the various circuit courts?

Mr. McEvoy. A very good idea.

Mr. COE. May I ask Mr. McEvoy one question? Would you be in favor of making the Patent Office the tribunal of last resort so far as the issuance of patents is concerned?

Mr. McEvoy. Yes.

The CHAIRMAN. Are there any other questions to be asked of Mr. McEvoy?

Mr. DESSION. Before we adjourn, Mr. Chairman, I should like to have certified as original exhibits, not to be printed, two statements, one as a statement of royalties paid and collected by General Motors, as has already been referred to. That is correct, is it not?

Mr. McEvoy. Yes.

Mr. DESSION. And a statement of the same material for 1937.

The CHAIRMAN. The statements will be accepted.¹

Mr. COX. I should like to make a statement before we adjourn, if I may. We had hoped to have Mr. Keller of the Chrysler Co. here to testify as representative of another large motor car company which has been a party to the cross-licensing agreement. Mr. Keller, however, had some urgent engagements and in view of that we excused him, and that is the explanation for our failure to call any one of the large manufacturers that was a party except General Motors.

We had also hoped to have a representative of a smaller manufacturing company present, a company which has also part in the cross-licensing agreement, and for the same reason we were unable to obtain a representative there, and therefore had to abandon that.

The CHAIRMAN. You have no other witnesses?

Mr. COX. Not so far as the automobile industry is concerned. This concludes our presentation of that aspect of our hearings. The next thing we plan to take up is the glass industry.

The CHAIRMAN. That will also be a patent inquiry?

Mr. COX. That is also a patent inquiry.

The CHAIRMAN. Mr. McEvoy, we are very much indebted to you for your presence here and for your testimony.

The committee will stand in recess until Monday morning at 10:30.

(Whereupon, at 4:30 p. m., an adjournment was taken until Monday, December 12, 1938, at 10:30 a. m.)

¹ Previously received and marked as "Exhibits Nos. 107 and 107-A," *supra*, p. 367.

INVESTIGATION OF CONCENTRATION OF ECONOMIC POWER

MONDAY, DECEMBER 12, 1938

UNITED STATES SENATE,
TEMPORARY NATIONAL ECONOMIC COMMITTEE,
Washington, D. C.

The committee met at 10:45 a. m., pursuant to adjournment on Tuesday, December 6, 1938, in the caucus room, Senate Office Building, Senator Joseph C. O'Mahoney presiding.

Present: Senators O'Mahoney (chairman) and Borah; Representatives Reece and Sumners; Messrs. Arnold, Henderson, Patterson, Lubin, Davis, Frank, and Berge.

Present also: Department of Justice staff for Temporary National Economic Committee study—counsel, H. B. Cox (Special Assistant to the Attorney General); Joseph Borkin, Ernest Meyers, Charles L. Terrel, Benedict Cottone, David Clarke, George Dession, Fowler Hamilton, H. C. Engelbrecht, Victor H. Kramer, J. M. Henderson, Monroe Karasik, Irving Glickfeld, Hyman Ritchin, Norman Bursler, and Seymour Lewis; also chief counsel for Federal Trade Commission Temporary National Economic Committee study, George W. Williams.

The CHAIRMAN. The committee will please come to order.

Mr. Arnold, you have further proceedings to take place this morning?

Mr. ARNOLD. Yes, Mr. Chairman. I will introduce Mr. Cox to make a statement.

Mr. Cox. Mr. Chairman and members of the committee, this morning the Department of Justice begins the presentation of material relating to the use of patents in the glass container industry. The patents involved cover machinery used to manufacture glass containers; the material presented is intended to disclose the relationship existing between those patents and competitive conditions in the industry.

It is important at the outset to emphasize the purpose for which this presentation is made. The Department has selected this material for presentation because it believes that the material throws light on problems which arise in connection with the enforcement of the anti-trust laws. The public policy embodied in those laws rests on the assumption that the maintenance of a free and open market in which neither production nor price is subject to artificial limitations or control is socially and economically desirable. The patent privilege is a limited exception to that policy. To the extent that the Department of Justice is interested in the patent law, its interest is confined to the question of the relationship between patent practices and the free and open market which it is the purpose of the anti-trust laws to maintain.

The Department is not concerned with the patent law as such or with the details of its administration. What is a good patent law, whether the present patent law fulfills its constitutional purpose,

and what changes with a view to improvement could be made in its substantive or procedural provisions are questions with which this Department has no direct concern. The Department asks that the committee in hearing this testimony bear in mind that there are two separate and distinct questions: (1) Is the present patent law equitable and effective merely as a patent law? and (2) What is the relation between the patent law and the enforcement of the antitrust laws? It is the second question in which the Department is interested and it is to the second question that this hearing is addressed. From time to time during the course of the hearing certain evidence may be adduced with respect to certain practices in connection with the administration of the patent law. In each instance, however, the Department presents this evidence because it believes that a direct and substantial relationship exists between the practice described and the enforcement of the anti-trust laws. It does not present this evidence to criticize particular details of the patent law or its administration or with a view to suggesting at this time any changes in its provisions.

At this point in its presentation of material the Department takes no position with respect to the legality or the economic desirability of the practices which will be revealed by the testimony. Its only purpose now is to present the facts with respect to an industry in which patents are of the utmost importance and in which the restrictive use of these patents has had a substantial effect upon competitive conditions.

Two more matters, I think, should be briefly adverted to before the presentation of testimony begins.

The CHAIRMAN. May I interrupt you, Mr. Cox, to ask if I am correct in understanding the statement which you have just made to mean that the presentation of any evidence or testimony this morning does not necessarily mean that the Department of Justice believes that any of the practices which will be revealed involved a violation of the antitrust laws?

Mr. Cox. I would not go that far. I would say that in presenting the testimony we are not taking any position in this hearing as to the legality. What opinion the Department might have in the course of the administration of its regular duties is quite another matter which I should prefer not to comment on now, with your permission.

The only point I make there is that we will not regard this hearing as being held for the purpose of trying violations of the antitrust law. If the Department believes those laws are being violated, it will try that condition somewhere else, is the point I wish to make.

There are two other matters to which I wish to refer. From time to time, with regularity throughout the testimony, it is going to be necessary to refer to machines and certain technical processes used in the manufacture of glass. In the hope that it might make it possible for the committee and others to follow the testimony the Department has prepared this small pamphlet, entitled "The Manufacture of Bottles." It contains a brief description of the processes used in manufacturing glass and certain figures and pictures which illustrate those processes. As the testimony develops, I shall try at appropriate times to refer to passages in the booklet which will make clear the testimony which is being given.

I also wish to make it clear that the testimony which we are going to hear relates to the manufacture of glass containers. It has nothing to do with plate glass or flat glass or window glass. It relates to containers, such as milk bottles, to the jars the housewife preserves fruit in, all the glass containers that food packers pack food in for distribution to the ultimate consumer, and all kinds of bottles.

If the fact is borne in mind, I think it will assist the committee, and others, to follow the testimony.

Mr. ARNOLD. That happens to be the major portion of the glass industry?

Mr. COX. That is correct; yes.

The CHAIRMAN. It may be improper for me to remark at this point that, if I understand correctly the attitude of the members of the committee their interest in the study of patents is primarily one which involves the use of the resources of the country. We are concerned to know whether or not the patent law as it now stands upon the books and the practices which are followed under it by any means restricts the maximum use of our resources.

Senator BORAH. Or tends to establish monopoly.

The CHAIRMAN. Or tends to establish monopoly. Right you are You may proceed.

Mr. COX. The first witness will be Mr. F. Goodwin Smith and Mr. A. T. Safford.

While we are waiting, I should like to have this book entitled "The Manufacture of Bottles" put into the record, if I may.

The CHAIRMAN. If you desire, without objection, it is so ordered.

(The book referred to was marked "Exhibit No. 112" and is included in the appendix on p. 736.)¹

The CHAIRMAN. Will the witnesses please be sworn? Do you solemnly swear that the testimony that you are about to give in this proceeding shall be the truth, the whole truth, and nothing but the truth, so help you God?

Mr. SMITH. I do.

Mr. SAFFORD. I do.

TESTIMONY OF F. GOODWIN SMITH, PRESIDENT, HARTFORD-EMPIRE CO., HARTFORD, CONN.; AND A. T. SAFFORD, SECRETARY AND COUNSEL, HARTFORD-EMPIRE CO., HARTFORD, CONN.

Mr. COX. Will you give the reporter your full name and address?

Mr. SMITH. F. Goodwin Smith, president, Hartford-Empire Co., Hartford, Conn.

Mr. SAFFORD. Arthur T. Safford, Jr., Hartford, Conn.

Mr. COX. Mr. Smith, you are at present a director and member of the executive committee of the Hartford-Empire Co.?

Mr. SMITH. That is correct.

Mr. COX. Mr. Safford, you are the secretary of the company?

Mr. SAFFORD. That is correct.

Mr. COX. You are also a member of the bar of the State of Connecticut?

¹ See revisions of Hartford-Empire Co. subsequently entered as "Exhibits Nos. 116 and 117," appendix, pp. 765 and 766.

Mr. SAFFORD. That is correct.

Mr. COX. The principal office of the Hartford-Empire Co. is in Hartford, Conn.?

Mr. SMITH. That is correct.

Mr. COX. It is a Delaware corporation?

Mr. SAFFORD. A statutory office.

Mr. COX. Does your company own patents and patent rights on automatic machinery used in the manufacture of glass, is that correct?

Mr. SMITH. Correct.

Mr. COX. Can you tell us now how many patents of that kind the company owns today?

Mr. SMITH. Not exactly. I think we own possibly a little over 700. That can be checked.

Mr. COX. You have that figure. It is about 720.

Mr. SMITH. I am told it is 717.

Mr. COX. Do you manufacture any glass making machinery yourself?

Mr. SMITH. We have it built for us.

Mr. COX. You have it manufactured by someone else?

Mr. SMITH. Correct.

Mr. COX. You don't manufacture any glass containers yourself.

Mr. SMITH. We do not.

Mr. COX. The machinery which you have manufactured for you by someone else you license to others, is that correct?

Mr. SMITH. Correct.

Mr. COX. Retaining in each case the title to the machinery?

Mr. SMITH. Correct.

Mr. COX. You never sell any machines at all?

Mr. SMITH. No.

Mr. COX. In connection with those licenses you also perform certain services for your licensees.

Mr. SMITH. Correct.

Mr. COX. Would you say the largest part of the income of your company is derived from license fees and royalties from your patents?

Mr. SMITH. The largest part of our income is derived from royalties.

Mr. COX. That in fact runs as high as upwards of 90 percent, doesn't it?

Mr. SMITH. I presume somewhere near there. I haven't figured it out exactly.

Mr. COX. How many people do you employ?

Mr. SMITH. About 300 people.

Mr. COX. And you have a plant at Hartford.

Mr. SMITH. We have an office, a large engineering office, drawing rooms, a little plant for spare parts, and in addition to that we have a glass plant which is used for research and development and experimentation.

Mr. COX. Just an experimental plant; it produces no glass?

Mr. SMITH. That is all. We develop our ideas and inventions in that plant. We do not sell any glassware.

Mr. COX. Do you have in your papers a copy of your balance sheet as of the end of December 1937, Mr. Smith?

Mr. SMITH. Yes.

Mr. Cox. You had total assets as of that date of about \$11,000,000, is that correct?

Mr. SMITH. Correct.

Mr. Cox. You also had a cash reserve of about \$229,000.

Mr. SMITH. Yes; correct.

Mr. Cox. Another item just labeled "Cash," of seven-hundred-eleven-some-odd thousand dollars, is that correct?

Mr. SMITH. Correct.

The CHAIRMAN. May I interrupt, Mr. Cox. Mr. Smith, the acoustics in this room are abominable. If you can find it convenient to talk a little bit louder, I am sure the persons who are gathered here will hear more readily.

Mr. SMITH. I will be very glad to do so.

The CHAIRMAN. This is particularly asked on behalf of the newspapermen.

CONTROL OF AN INDUSTRY THROUGH PATENTS

Mr. Cox. Taking the machines that are involved in the automatic manufacture of glass, Mr. Smith, it is true, isn't it, that those machines, speaking generally, are the furnace, the feeding machine, the forming machine, and an annealing oven?

Mr. SMITH. Correct.

Mr. Cox. Does your company hold patents on all of those machines?

Mr. SMITH. Yes.

Mr. Cox. Now the automatic feeder, Mr. Smith, is a very important machine so far as the commercial production of glass is concerned.

Mr. SMITH. Correct.

Mr. Cox. It would be impossible for a man who attempted to perform that process by hand in a plant to compete with one who used an automatic feeder, wouldn't it?

Mr. SMITH. In most lines of ware, the majority lines. There are still hand plants in existence.

Mr. Cox. Those are for restricted items, such as expensive perfume and cosmetic bottles.

Mr. SMITH. Yes.

Mr. Cox. As far as the great mass of glass containers is concerned, that kind of competition isn't possible.

Mr. SMITH. As far as the great mass of containers is concerned, they are made automatically by different processes.

Mr. Cox. And your company, as you said a moment ago, holds patents on machines for the automatic feeding of glass.

Mr. SMITH. Correct.

Mr. Cox. And now, isn't it true, Mr. Smith, that so far as those machines and those patents are concerned, your company has virtually a monopoly on the patents which relate to that process?

Mr. SMITH. As far as those particular types are concerned, which are owned and developed, we have a monopoly as regards that particular type of machine. That is the monopoly which is given to us by the patent.

Mr. Cox. In the first place, I would like to know a little more definitely what you mean by a particular type. Do you mean simply the so-called plunger feeder, or do you mean the gob feeder generally as distinguished from the suction feeder?

Mr. SMITH. There are two economical means of producing glass-ware, which are the most economical. There are other means of pro-

ducing glassware. There is the Owens suction machine which is an entirely different method from what Hartford developed, and there is the Hartford machine which is generally known or called a plunger feeder, and represents a method of gob feeding.

Mr. Cox. So far as that plunger feeder is concerned, or in fact any kind of a feeder whose principle consists of having glass flow through an orifice and then being severed in suspension, your company has a monopoly, has it not, Mr. Smith?

Mr. SMITH. Well, we think we have covered by patents the particular devices which we license and lease. There are other old methods, stream feeding, and things of that sort, which we feel are not as economical as our methods. They can be generally used as seen fit by various people if they want to use them.

Mr. Cox. Some of your patents would even cover the old stream-feed methods in some respects, wouldn't they?

Mr. SMITH. That I wouldn't know.

Mr. Cox. I will develop that point later. Taking for a moment that stream-feed method of producing glass, there is only a limited kind of ware that that could be used for, isn't that true, Mr. Smith?

Mr. SMITH. I wouldn't feel qualified to say.

Mr. Cox. You feel you can't express an opinion.

Mr. SMITH. I would say it is not as good as our method.

Mr. Cox. Except for the stream-feed method of feeding glass and the Owens suction method, can you think of any method on which your company doesn't have a patent?

Mr. SMITH. No; no known method that we are aware of.

Mr. Cox. Of course you know, don't you, Mr. Smith, that the Owens-Illinois Co., which has the patents on the suction method of feeding glass, has not granted any new licenses since 1914?

Mr. SMITH. I wouldn't know it, no. It may be a fact.

Mr. Cox. If I suggest that to you, and then ask this question, isn't it true that if a man wished to go into the business of producing glass and wished to get an automatic feeder, there is only one place in the United States that he can go to get that feeder, and that is your company, would you answer me in the affirmative?

Mr. SMITH. If he wanted to go into business and use gob feeding as a method for producing his ware, he would probably come to Hartford.

Mr. Cox. He would have to come to you.

Mr. SMITH. If he wanted to use gob feeding.

Mr. Cox. The only other thing he could use really would be the suction method.

Mr. SMITH. He could go to the Owens Co. and ask for a license.

Mr. Cox. He would have to go to you or Owens.

Mr. SMITH. Or he could use the old methods or buy his way into the industry by picking up some plant that had a license.

Mr. Cox. I am speaking about a man who doesn't want to buy his way into the industry but wishes to start himself with new capital and new plants.

Mr. SMITH. If he wanted to use our equipment he would have to come to us.

Mr. Cox. He would have to get your equipment, wouldn't he, or the equipment of the Owens Co.?

Mr. SMITH. If he wanted to use our process.

Mr. Cox. If he wanted to use any process. There are only two that are available.

Mr. SMITH. Only two that are the most economical.

Mr. Cox. And the reason you qualify that is because you have in mind the old stream feed, is that right?

Mr. SMITH. Right.

Mr. Cox. So if I could demonstrate to you presently that certain of your patents cover the stream feed, at least so far as it is now commercially practical to operate, that demonstration would leave us in a position where a man would have to come either to you or to Owens-Illinois, if he wished to go into the business of producing glass.

Mr. SMITH. If that was demonstrated, yes, unless he produced glass by the hand method.

Mr. Cox. Of course, if he were going to produce glass by hand he couldn't compete with anybody else producing it automatically.

Can you tell us how much of the percentage of the total production of glass containers in this country your company licenses?

Mr. SMITH. About 66, 65, or 67 percent.

Mr. Cox. I show you a sheet, rather the photostatic copy of a sheet, which was taken from your file headed "Memorandum to F. G. Smith, from survey statistical department," and I point out to you that on that sheet the figures indicate that in 1937, your company licensed 67.4 percent of all the glass containers produced in the industry. Do you believe that is correct?

Mr. SMITH. That is substantially correct.

Mr. Cox. I also point out to you the same sheet shows that Owens-Illinois, licensed in 1937 suction feeders which produced 29.2 percent of all glass containers produced in the country.

Mr. SMITH. Owens suction here is 21—

Mr. Cox (interposing). I think you have that wrong.

Mr. SMITH. 29.2?

Mr. Cox. That is correct?

Mr. SMITH. As far as I know.

Mr. Cox. You are satisfied with the substantial accuracy of the figures?

Mr. SMITH. Yes; substantially correct.

Mr. Cox. So that less than 3 percent of the glass containers that are produced, were produced in this country in 1937 by someone who is not a licensee of yourself or not a part of the organization of Owens-Illinois?

Mr. SMITH. I think it is around 2 something. Generally speaking, that is correct.

Mr. Cox. I will now hand you and Mr. Safford copies of the chart which the Department has prepared, labeled "Major intercompany relations in the glass container industry."¹ I call your attention first to the three small circles on the extreme right, the first one marked "Alexander Kerr," the second "Obear-Nester Glass Co.," and the third, "F. E. Reed Glass Co." Now I ask you if it isn't a fact that not one of those three companies is a licensee of the Hartford-Empire?

Mr. SMITH. That is correct. We wish they were.

¹ Later introduced as "Exhibit No. 113," see *infra*, p. 385.

Mr. Cox. But they are not?

Mr. SMITH. They are not.

Mr. Cox. Can you tell us now whether there is any other company aside from the subsidiaries—I will withdraw that for the present.

I now call your attention to the companies which are shown at the end of the lines radiating from the Hartford-Empire Co., and I ask you to glance over those and tell me if it is true that those companies are all licensees of your company. Perhaps Mr. Safford might do that.

Mr. SMITH. I assume you have the list.

Mr. Cox. I assure you that is correct, they are licensees of your company. Now I ask you, Mr. Smith, whether there is any other company, aside from the subsidiaries of Owens-Illinois, which stand in a different category besides the three companies on the extreme right, which is not a licensee of your company, that produces glass containers?

Mr. SMITH. I can't think of any other companies right now.

Mr. Cox. You can't think of any others now, so that if we use the word "independent" company as meaning a company which is not a part of Owens-Illinois, or not licensed by Hartford-Empire, to your knowledge there are only three such independent companies producing glass containers in the United States today?

Mr. SMITH. Correct.

Mr. Cox. I call your attention to the fact that this chart also shows 40 percent of the stock of the Hartford-Empire Co. is owned by the Empire Machine Co. Is that correct?

Mr. SMITH. Correct.

Mr. Cox. And that your company has a cross-license agreement with the Lynch Corporation?

Mr. SMITH. Correct.

Mr. Cox. And also the Owens-Illinois Corporation?

Mr. SMITH. Correct.

Mr. Cox. Mr. Chairman, I should like to have this chart showing the major intercompany relations in the glass container industry introduced in evidence now. I am aware that all of the relationships shown on the chart have not yet been proved, but I ask you to take it subject to proof, which I shall offer later on. I should like to have it in. I think it would be convenient as a matter of record.

Representative SUMNERS. May I ask this question? Can't you stipulate without going into detail?

Mr. Cox. The point is that these gentlemen are not at the moment probably able to testify or even to stipulate everything that is shown on there.

The CHAIRMAN. This chart was prepared by the Department of Justice from information secured from all of these companies, and particularly from the company represented by the witness here today?

Mr. Cox. That is correct, and the other companies. Some of the things shown on the chart relate to the relationships between other companies and the industry, but it is correct to the best of our knowledge and belief, and I have no doubt we shall be able to establish it.

The CHAIRMAN. Unless there is some objection on the part of some member of the committee, the chart may be admitted.

(The chart referred to was marked "Exhibit No. 113" and is included in the appendix on p. 762, the legend for the chart is included on p. 763.)

Mr. Cox. Of course, as far as particular lines of ware is concerned, Mr. Smith, it is true, isn't it, that your company licenses far more than merely 67 percent of all production in this country?

Mr. SMITH. I don't know as I understand your question, Mr. Cox.

Mr. Cox. Take milk bottles, for example, what percentage of all the milk bottles produced in this country in a given year would you say are licensed by Hartford-Empire?

Mr. SMITH. I would say most all of them.

Mr. Cox. Practically all of the milk bottles are produced under license of Hartford-Empire? What about fruit jars?

Mr. SMITH. There would be three companies making fruit jars.

Mr. Cox. Would you say that an estimate of about 80 and 85 percent of all the fruit jars in the country were produced under license by Hartford-Empire?

Mr. SMITH. Somewhere near there.

Mr. Cox. Somewhere in that neighborhood.

Now, packers ware. For the information of the committee, packers ware includes all the kinds of jars that food products are packed in. That is correct, isn't it?

Mr. SMITH. Yes.

Mr. Cox. Would you say that about 80 percent of the packers ware—

Mr. SMITH (interposing). That I wouldn't know. I haven't looked it up.

Mr. Cox. You testified a little while ago as to the number of your patents, Mr. Smith. I should like to ask you some questions as to the purpose of your company in taking out patents.

Representative SUMNERS. Mr. Cox, before you leave that do you propose to develop at any time during the examination from any other witnesses as to how many of these different licensees are competing amongst themselves in the production of various particular sorts of glassware? You have, for instance, I notice, the Ball Bros. fruit jars, and then a number of others. Are all these licensees licensed to produce any sort of glassware which they may want to produce, or are they licensed to produce particular sorts of glassware?

Mr. Cox. They are not licensed to produce any sort of glassware they want to.

Representative SUMNERS. I don't want to interfere with your examination, but as one individual member of the committee I wanted to go into that.

Mr. Cox. I planned to go into it. I will do it now, if you prefer.

Representative SUMNERS. Not at all, sir.

Mr. Cox. What would you say was the primary purpose of your company in taking out patents, Mr. Smith?

Mr. SMITH. To protect our inventions so that when our equipment comes into public use and somebody tries to copy or pirate or infringe it, we will have the right to go before the court to defend our rights.

Mr. Cox. Now, to be sure that I understand that answer, you mean by that, do you, that you take out patents so that you can license or

use the machines which your own patents cover without fear of infringement suits?

Mr. SMITH. To protect our invention.

Mr. Cox. Is that the only purpose you have in taking out patents, Mr. Smith?

Mr. SMITH. I don't know of any other purpose, unless at times we will feel that in the future the trend of the industry may go this way or that way, and somebody comes along with an idea that may affect our future, if we think it is worth patenting it, we patent it.

Mr. Cox. Those two statements are your considered answer to my question, are they, Mr. Smith?

Mr. SMITH. It is what I believe.

Mr. Cox. Now, Mr. Smith, I am going to hand you a photostatic copy of a document dated February 18, 1930, which was removed from your files, and I am going to ask you if you know who prepared that document.¹ It is not signed.

Mr. SMITH. I think that memorandum was written by Mr. Herbert Knox Smith.

Mr. Cox. Will you tell us briefly who Mr. Herbert Knox Smith was?

Mr. SMITH. Herbert Knox Smith for a number of years was here in Washington, a Commissioner in the Department of Commerce, I think—Commissioner of Corporations. He then returned to Hartford and joined our organization and handled our legal matters outside of patent matters.

Mr. Cox. How long was he connected with the corporation?

Mr. SMITH. At first, in the early days, I think it was probably around '18 or '17. I have forgotten exactly, he gave us part of his time, and as the company commenced to grow he gave it practically all of his time.

Mr. Cox. He was very active in the company's affairs, then?

Mr. SMITH. As regards our legal matters, yes, very.

Mr. Cox. And had a voice in determining the company's policy sometimes?

Mr. SMITH. Yes.

Mr. Cox. Mr. Smith, I am now going to call your attention to a statement contained on page 17 of this memorandum, if you will find page 17. The heading there is [reading from "Exhibit No. 125"]:

The Main Purpose In Securing Patents.

Do you see that, Mr. Smith?

Mr. SMITH. Yes.

Mr. Cox. It then reads as follows [reading further]:

In taking out patents we have three main purposes; (a), to cover the actual machines which we are putting out, to prevent duplication of them.

Stopping there, that, as I understood it, was the answer you gave a moment ago.

It then goes on to say:

The great bulk of our income results from patents. Between a feeder protected by patents * * *

And so forth. I am not going to read that at the moment.

¹ Subsequently entered in record as "Exhibit No. 125"; see infra, p. 433.

Now I call your attention to (b), which is the second main purpose stated in securing patents [reading further from "Exhibit No. 125"]:

To block the development of machines which might be constructed by others for the same purpose as our machines, using alternative means.

I would like to ask you exactly what you meant by that.

Mr. SAFFORD. That is not Mr. Goodwin Smith's testimony.

Mr. COX. I am aware of that, but I assume the memorandum is an accurate statement of the company's policy.

Mr. SMITH. I don't happen to remember the memorandum. I don't know what was considered, but I think I can answer your question.

Mr. COX. I would like to straighten up this one thing. This may be Mr. Smith's out.

Mr. GOODRICH (of counsel for witness). He doesn't need an out.

Mr. COX. Is it your policy to take out patents to block the development of machines which might be constructed for the same purpose as your machine?

Mr. SMITH. Only in so far as to protect our own machines.

Mr. COX. There is no qualification of that kind in that memorandum, is there?

Mr. SMITH. Not as it reads.

Mr. COX. You mean you only take out a patent to block the development of some other patent when you are afraid somebody else is going to sue you?

Mr. SMITH. No; I am not cognizant of any such purposes or any such means. If we think that a new idea might be developed over a course of the year by someone else, and we think that idea may affect our machinery and our licenses, we may from time to time try to protect that idea.

Mr. COX. Regardless of whether you intend to commercially apply the idea yourself or not?

Mr. SMITH. You can never tell when you are going to commercially employ ideas. The scene shifts every year or two or three years. Let me give you an example. Today we are spending quite a lot of money on a research development which will be partially and quite well covered by a patent which was taken out in '34. At that time we thought it might have some possibilities; then all of a sudden, in '37, something transpires that makes that patent a very valuable patent, we hope, one that will be of great benefit to the trade at large when it is put in a process form.

You just can't tell when a thing is going to be good and when it is going to be bad. An inventor never knows when or how, or how long it is going to take his invention to be proved of value. It may never be of any value; it may be of great value. You just can't tell.

Mr. COX. When you take out a patent to an invention to block the development of machines which might be constructed by others for the same purpose as yours, using alternative means, isn't it a fact that you are more interested in preventing the use of that device by someone else than you are in using it yourself?

Mr. SMITH. No; I don't think so. So long as I have been with the company I am not conscious of any policy of definitely, deliberately, going out and blocking people. We do take patents out and have a number of additional patents, so that we are protecting and may protect our main development of machinery.

Mr. Cox. When you say "protect the main development of machinery" don't you mean to prevent someone else from developing a machine which will accomplish the same purpose, using alternative means?

Mr. SMITH. I don't know if you would say that was wholly so. If we felt that a machine might be improved, we will say, or somebody else might make improvements on our machines, we try to stop and figure out what those improvements might be, and we cover them as we can by patents.

Mr. Cox. Of course, about 90 percent of your company's income is derived from royalties under your licenses.

Mr. SMITH. Correct.

Mr. Cox. So that anyone who perfects a machine which will accomplish the same purpose that your feeders or other glass machinery accomplish, and obtains a patent on that, is in a position to strike a blow at your income.

Mr. SMITH. He is in a position to possibly affect our income or to affect our licenses.

Mr. Cox. He would affect your income, would he not?

Mr. SMITH. If he had a process that was efficient, one that we didn't have, yes. He could naturally do business. There is no monopoly on ideas and inventions.

Mr. Cox. And, of course, you are interested in preventing that kind of result, aren't you?

Mr. SMITH. Yes; normally interested, naturally.

Mr. Cox. And that is one of the reasons why you take out patents on devices you don't intend to put into commercial operation.

Mr. SMITH. I wouldn't say that was so, Mr. Cox. You had better ask our patent attorneys. It is a very difficult thing for me to answer your question "yes" or "no." We naturally have a big investment in our equipment. We spent a lot of money in developing it. We are looking for a return on that investment. As we put that out, if one of our engineers should come to us and say, "Well, now, here is something that might help," or if somebody else thought of this idea first it might cost us some money, naturally we file an application on that and hope to get a patent.

The CHAIRMAN. You maintain a research bureau?

Mr. SMITH. We do.

The CHAIRMAN. For the purpose of keeping abreast or perhaps a little ahead of the procession?

Mr. SMITH. And at all times being in a position to give our licensees the most efficient equipment, because otherwise they would go out of business.

The CHAIRMAN. But so far as you are concerned yourself, your desire is to get the new improvements first and get them patented first?

Mr. SMITH. Then comes a long development process, costing a great deal of money. Naturally we are out to get some return on our money.

The CHAIRMAN. So in order to protect the inventions you now have it is naturally in your interest to secure whatever hold you can upon any competing idea or competing machinery.

Mr. SMITH. Correct.

Mr. Cox. Not always with a view to using those ideas immediately, Mr. Smith?

Mr. SMITH. Yes and no. Sometimes yes, we do use them; sometimes we don't.

Mr. Cox. You would take out a patent if it would protect you against a competing machine even though you didn't intend to use it right away, wouldn't you?

Mr. SMITH. I just don't know.

Mr. Cox. Now, Mr. Smith, let's consider this for a moment. You know, of course, what the difference is between an automatic feeder which works with a vertical reciprocating plunger in the orifice, and one that works by air pressure, don't you?

Mr. SMITH. I know there are those two different types.

Mr. Cox. And the Hart^{ord} feeder, which you produce, has been a reciprocating plunger feeder?

Mr. SMITH. Primarily so.

Mr. Cox. Have you ever caused to be manufactured by you and licensed to anyone any feeders which worked by the air-pressure method?

Mr. SMITH. I think we have quite a few licensees who still use the air pressure.

Mr. Cox. What I am interested in is whether they got them from you or from someone else.

Mr. SMITH. We didn't build and put out as a standard thing an air feeder, if that answers it.

Mr. Cox. You don't do it at all, do you? You don't build and put out, and never have, and licensed it?

Mr. SMITH. Never have built, no.

Mr. Cox. All these air feeders your licensees are using now are licensed and bought in the first instance from someone else?

Mr. SMITH. I think substantially that is correct.

Mr. Cox. Yet you have patents on air feeders?

Mr. SMITH. That is true.

Mr. Cox. And you sue people who are using air feeders in their business, even though you have no intention at the present time of developing or commercially supplying an air feeder?

Mr. SMITH. We did develop in the early days an air feeder. I think Mr. Peiler could give you that history. I think it would be quite enlightening for the committee if they heard how we came into being, and in those early days, as I remember it, Mr. Peiler did develop an air feeder and then chose between the air feeder and the plunger feeder.

Mr. Cox. Since that choice you have adhered to the plunger feeder, so far as to your own commercial development?

Mr. SMITH. Quite correct.

Mr. Cox. Yet you have sued people for infringement on the air feeder. Isn't that a case where you have been using a patent to block the development of machines constructed by others for the same purpose as your machines, which use an alternative method? You

have no interest in an air feeder so far as commercial development is concerned.

Mr. SMITH. Now, Mr. Cox, I am not a patent attorney. I can give you this picture. If we have patents covering two types of feeders and we choose to say that this type is the better of the two, that is what we license, and I see no reason why, if we have patents covering the other type of feeder, namely the air feeder, we shouldn't take advantage of those patents and protect our rights.

Mr. Cox. You mean your rights under the patents, even though you are not using that patent for the purpose of producing feeders and licensing them to others?

Mr. SMITH. Yes.

Mr. Cox. You are protecting your rights there really for the purpose of protecting your revenue from your other patents. Is that correct?

Mr. SMITH. Not entirely.

Mr. Cox. You know, don't you, and I suppose you have seen it, of the provision in the Constitution which makes it possible for the Federal Government to enact patent laws?

Mr. SMITH. I know there is such a provision.

Mr. Cox. Do you know that the tenor of the provision is that Congress shall have power to enact such laws for the purpose of promoting the progress of science and useful arts. You have heard that phrase, "science and useful arts"?

Mr. SMITH. I have.

Mr. Cox. Mr. Smith, do you think the use which you make of those patents of yours on air feeders is a use which does promote science and the useful arts?

Mr. SMITH. I would say yes, because they are our original inventions, and I see no reason why, if we choose one type of machine, we still shouldn't protect ourselves on the other.

Mr. Cox. Someone else using those machines might develop the machines to a place where they were greatly improved, might he not?

Mr. SMITH. I suppose that might be so.

Mr. Cox. Yet you prevent anyone else from attempting or undertaking that kind of enterprise?

Mr. SMITH. No; not deliberately.

Mr. Cox. You do if you sue him for infringement and get an injunction.

Mr. SMITH. We sue for infringement because we think people have either copied or are using our rights without legal permission.

Mr. Cox. The upshot of that position is this, is it not, that there is only one person, according to your view, who has a right to use or develop an air feeder, and that is your company, and you are not interested in doing it on a commercial scale?

Mr. SMITH. We would be if we thought the air feeder was more efficient than the plunger feeder.

Mr. Cox. You decide that question for the people who want to use the air feeder, don't you?

Mr. SMITH. I do not think so. We have licensed air feeders. I think there are quite a number of feeders operating today that are air feeders.

Mr. Cox. I am sure of that, but again I suggest to you that each of those air feeders which you have licensed is a feeder which was

manufactured by someone else, licensed or sold outright to a glass manufacturer, and then, by virtue of circumstances which I hope to develop in this hearing, that manufacturer found himself in a position where he had to take a license from you to cover that feeder, even though you never manufactured the feeder and he had never had any relationship with you before the time he took the license. Those are not feeders you built yourselves and licensed to the glass manufacturers. I am talking about the things you do yourself.

Mr. SMITH. Now, if that manufacturer infringed on our rights and a court so held, we would give him his choice, and have so done, either to use an air feeder or to use a plunger feeder, whichever he thought was most efficient for his type of business.

Mr. Cox. But if he wanted to use the air feeder, he has to pay royalty to you.

Mr. SMITH. Quite right. If he wants to use the air feeder which the courts have said is our property, why then he has to pay royalty to us.

Mr. Cox. Now, Mr. Smith, I want to call your attention to the second paragraph, under (b), in this memorandum on page 17, which reads in part as follows [reading from "Exhibit No. 125"]:

We have in mind such machines as * * *.

I just want to ask you to look, Mr. Smith, at the feeders named in the first paragraph under (b) on page 17.

Mr. SMITH. Those are all suction machines.

Mr. Cox. I call your attention to that because a little while ago you spoke about the stream feeder not being covered by your patents. This suggests to my mind that perhaps you did take out some patents which covered the improved stream feeder.

Mr. SMITH. I couldn't answer. It might be so and might not.

Mr. Cox. I now want to call your attention to (c) on the next page of this memorandum, which is the third primary reason stated here. That reads [reading from "Exhibit No. 125"]:

To secure patents on possible improvements of competing machines so as to "fence in" those and prevent their reaching an improved stage.

As I understand that statement, Mr. Smith, and I assume that it represents the policy of your company, it means, in some cases you secure patents on devices which are merely improvements on devices which are covered by patents held by someone else. Is that correct?

Mr. SMITH. That is not a corporate policy.

Mr. Cox. Are you repudiating this memorandum, Mr. Smith?

Mr. SMITH. As a corporate policy, or as ever having this memorandum come before the board of directors, or as having been approved as a statement of our entire policy, I am.

Mr. Cox. You told us a little while ago Mr. Smith was a man who had been with the company for many years and was active in its affairs. Would he seriously state in his memorandum, "in taking out patents we have three main purposes" when that was not the case?

Mr. SMITH. I don't know how that memorandum was written or why. I do happen to remember that I have seen a copy of it and read it, at the time it was written. When we come to the question of deliberate policy or setting engineers to work to prevent others from getting certain things, that isn't a corporate policy. There are a great many times when an inventor will come in and say, "Now, I

have this idea or that idea," and it will encompass part of some other machine and we do file application and get together a patent.

Mr. COX. Then you want us to understand now that when you do that you don't do it for the purpose of fencing in the other man's invention and preventing it from reaching an improved stage?

Mr. SMITH. I don't like the words "fencing in."

Mr. COX. It is not my word, Mr. Smith.

Mr. SMITH. We do that off and on as the occasion arises.

Mr. FRANK. Would you consider it improper for you to adopt the policy indicated in paragraph (c)?

Mr. SMITH. I don't think we would deliberately go out and spend our time and money in a fencing-in policy.

Mr. FRANK. My question is not whether you have done so, but whether you would consider it improper to do so.

Mr. SMITH. No; I think you have to protect your large investments; you have to protect your licensees. If you don't protect your licensees, they can't stay in business.

Mr. FRANK. Well, whether that has been your policy or not, you wouldn't consider it improper for your company to adopt such a policy?

Mr. SMITH. No.

Mr. COX. That would be because you think it is necessary to protect your licensees?

Mr. SMITH. Insofar as that policy protects our investment, protects our licensee, we would say it is all right.

Mr. COX. Just how does that policy protect the licensee?

Mr. SMITH. The licensee looks to us to continually improve the equipment that he is using, to take certain machines and add things to them, to increase his speed, to better his quality, to help him in the glass furnace troubles, to enter in and show him how to make bottles at the lowest possible cost, to give him the advantage of what we find in other plants and how they are operating, to at all times keep him in a competitive situation; otherwise, he can't live. Now, if we saw over in one corner something that we thought was desirable, even though it was going to head off somebody else, and we should be the first to invent that and get a patent on it that is going to assist us by protecting us or help our licensee, we would so do it.

Mr. COX. Isn't it possible, Mr. Smith, that if you didn't fence in someone else's invention, he might invent a device which your licensee could use?

Mr. SMITH. I suppose that is possible, but I don't think the invention would be at all basic or original.

Mr. COX. Well, it is really not necessary for the protection of your licensees for you to stifle inventions on the part of everyone else.

Mr. SMITH. I am not conscious of the fact that we have a policy that wants to stifle. We have a policy that wants to protect what we are doing and wants to insure our licensees of the best possible means of producing glassware at the lowest cost.

Mr. ARNOLD. May I get that a little clearer in my own mind, Mr. Smith? Your licenses—I don't know how long they run—

Mr. SMITH (interposing). They run, some of them, 8 years, with a renewal, and some of them for the life of the patent.

Mr. ARNOLD. That is a contract which your licensee has and which you have against the licensee?

Mr. SMITH. Right.

Mr. ARNOLD. Now, if a new development should occur so that another machine could compete with that machine which you have licensed, then both you and the licensee would be in a disadvantageous position because of that new competition?

Mr. SMITH. Right. We would probably go out of business because the licensee could cancel his contract with us. He could use the new development, the new process, and our income would cease.

Mr. ARNOLD. Therefore, to protect that 8-year license is not necessarily because you are anxious to stifle inventions, but to protect your own income it is necessary for you to fence in and stop this new machine from developing. Have I put it too—

Mr. SMITH (interposing). I think you have put it a little too strongly. I think I would say part of it is true, insofar as we protect ourselves, protect our future, and protect our licensee.

The CHAIRMAN. Let me put it this way: You do watch these competing machines, do you not?

Mr. SMITH. Yes; we do.

The CHAIRMAN. And in your research laboratory you study them for the purpose of developing improvements upon them?

Mr. SMITH. Right.

The CHAIRMAN. And if you do develop an improvement upon a competing machine, that thereby enables you to extend your influence, let me say, your contractual relationship over the competing machine or those who use it. A competitor could not use any of the improvement.

Mr. SMITH. That depends upon what the improvement is, the effect of it, whether it is incidental, or whether it is major.

The CHAIRMAN. Naturally it depends upon the importance or unimportance of the improvement. Let us assume that a very valuable improvement has been discovered simultaneously, or thereabouts, by the competing company, which is operating a competing machine, and you likewise developed one about the same time, then a conflict arises immediately, does it not, whether or not that improvement may be used without payment of royalty to you?

Mr. SMITH. Well, what would happen as a practical matter would probably be the stoppage on the part of both of us. The competitor might have 60 percent of the value of the invention and we might have 40, or vice versa, or some other percentage. Neither of us could go out because he would sue us, and if he went out, we would sue him, so it would probably mean that we cross-license.

The CHAIRMAN. Well, you are engaged in the business of inventing and patenting and you do this for the purpose of collecting license fees and royalties primarily.

Mr. SMITH. Correct.

The CHAIRMAN. So you watch the entire industry, and if you can extend the influence by means of invention over competing industries, you are going to do it because it means money to you.

Mr. SMITH. Correct, and also it keeps our licensee in a competitive situation.

The CHAIRMAN. So the incidental effect upon the development of science and arts—it is only an incidental effect so far as you are concerned.

Mr. SMITH. Perhaps I don't quite understand that question.

The CHAIRMAN. I mean your primary consideration is to make license fees and royalties out of these inventions?

Mr. SMITH. Right.

The CHAIRMAN. And you are willing to suppress the competition for that purpose, to fence it in? Well, I don't want to ask—

Mr. ARNOLD (interposing). Taking what your personal policy is out of this, the total situation illustrated by this picture is one in which whoever sits in your seat is under very strong pressure to protect his licensees by preventing competition in machines from arising, isn't it? Regardless of who sits there that pressure exists.

Mr. SMITH. I think that generally may be it.

Mr. FRANK. I would like to make a differentiation—

Senator BORAH (interposing). Let me make a suggestion, I think Mr. Cox ought to be permitted to develop his case.

The CHAIRMAN. The Senator is correct. That has been the policy formerly announced, and we have all been violating it, and we will refrain. Mr. Cox.

Mr. Cox. That is quite all right with me.

Two or three things have been developed in this which I should like to go into, and particularly Mr. Arnold's last question.

Mr. Smith. I am interested in that, because I wonder to just what extent your licensees are interested in preventing the development of a new device even by someone else which would enable them to produce, which could be used to produce glass. Isn't it true that your licensees are all engaged in producing and selling glass containers?

Mr. SMITH. Correct.

Mr. Cox. And let's assume for the moment that their primary interest is in producing and selling glass containers, and that as far as they are concerned, they will use any kind of machinery which will enable them to produce and sell glass containers, good glass containers at a good price, at which they can make a profit if they can get that machinery. Why wouldn't they be as content to get the machine or device from someone else as from you?

Mr. SMITH. You see, Mr. Cox, people that pay us royalties look upon us as the engineering and development and research concern that is going to develop machinery for them, that is going to keep them abreast of the times. They can't afford to spend large sums of money each year in research work, or development work, but they look to Hartford to take part of their royalties and spend money in the development work, glass compositions, anything that affects vitally the whole industry.

Mr. Cox. Do you think that part of the royalty money, at least that is paid to you, you take—I don't want to use too strong a word—in sort of a trust to use for development and experimental purposes?

Mr. SMITH. There is no question but that we have a deep sense of obligation to protect our licensees, to keep them in business, to continually reduce their cost and give them the most efficient equipment.

Mr. Cox. You feel that is almost a fiduciary responsibility.

Mr. SMITH. No: I don't think it is that, but I think it is just decent business ethics.

Mr. Cox. Do you think that they would feel that they hadn't had their money's worth if somebody else would perfect an invention that would enable them to produce glass more efficiently than yourself?

Mr. SMITH. I am quite sure if anybody else came along with an invention or process that was more economical than our process, that our licensees would cancel their contracts with us and install the most efficient process.

Senator BORAH. That would be competition.

Mr. SMITH. You can't help that, Senator. We have no monopoly on brains.

Mr. COX. You have a monopoly on some other things, though.

Well, isn't it a fact, really, Mr. Smith, that the important thing in this picture, so far as this "fencing in" is concerned, is 90 percent of your income which comes from royalties and not the feelings of your licensees?

Mr. SMITH. I couldn't answer that question.

Mr. COX. You feel you can't answer that question.

Mr. SMITH. I don't know what each individual licensee feels. I know that some of them feel that contact with us, the service we give them, is worth more than the royalties they pay. Some others might not.

Mr. COX. I was rather more interested in what you felt than what they felt. I was really inquiring whether in following this policy, your eye wasn't on the 90 percent of your royalties than on the feelings of your licensees.

Mr. SMITH. No; I think the sound policy, looking ahead, of any business is based primarily on the fact that you must serve your customers, and if you don't serve them you don't stay in business.

Mr. COX. Well, your customers would have a little difficulty going anywhere else, wouldn't they, Mr. Smith?

Mr. SMITH. Until there is something new comes on the market that is better than what we have.

Mr. COX. There isn't any place for them to go now, that is what I mean.

Mr. SMITH. They can go to suction.

Mr. COX. Well, if they went to suction, you would sue them.

Mr. SMITH. I don't know why.

Mr. COX. You are suing some people who are using suction.

Mr. SMITH. Not to my knowledge.

Mr. SAFFORD. What you refer to is not a suction machine.

Mr. COX. I withdraw that.

The only place they could get a suction machine would be from Owens.

Mr. SAFFORD. Not necessarily.

Mr. GOODRICH. I think Mr. Parham can give all the details of that.

Mr. COX. Except for the suction machine there is no place for them to go.

Mr. SMITH. Not to get the most modern equipment, or the most efficient.

Mr. PATTERSON. Let me ask, the patents in the suction machine have not expired, have they?

Mr. SMITH. The old original fundamental, basic patents have expired and if you and I wanted to go into business tomorrow we could build a suction machine under those original patents, or just the same kind of machine that was originally covered by those patents.

Mr. COX. It is true, isn't it, Mr. Smith—and perhaps we could get Mr. Parham to answer informally—that the machines now used by Owens, the suction machines, the improved machines, are covered by patents.

Mr. PARHAM. I understand you can build thoroughly good machines, if you happen to know how, under the old patents. That is my understanding.

Mr. COX. Mr. Chairman, I am about to start on a new topic. Is it your practice to adjourn at noon now or do you wish to go on?

The CHAIRMAN. I think probably, unless there is objection, it would be well, if you have finished this line of examination, to take a recess until 2 o'clock.

(Whereupon, at 11:55 a. m., a recess was taken until 2 p. m. of the same day.)

AFTERNOON SESSION

The committee resumed at 2:08 p. m., on the expiration of the recess. Present in addition to those previously listed: Senator King, Mr. Oliphant.

The CHAIRMAN. The committee will please come to order. Are you ready to proceed, Mr. Cox?

Mr. COX. Yes, I am, sir.

The CHAIRMAN. You may, then.

TESTIMONY OF F. GOODWIN SMITH, PRESIDENT, HARTFORD-EMPIRE CO., HARTFORD, CONN.—Resumed; TESTIMONY OF A. T. SAFFORD, SECRETARY AND COUNSEL, HARTFORD-EMPIRE CO., HARTFORD, CONN.—Resumed

Mr. COX. Mr. Smith, a few questions about the Hartford-Empire Co. which I didn't ask this morning I would like to ask now. Will you indicate briefly what the capital set-up of your company is? I mean, what kinds of stock you have outstanding. If you prefer, I will have Mr. Safford do this.

Mr. SMITH. It is common stock, no par value.

Mr. COX. Any preferred stock?

Mr. SMITH. None outstanding.

Mr. COX. No bonds?

Mr. SMITH. No.

Mr. COX. Is your stock listed on any of the exchanges?

Mr. SMITH. It is not.

Mr. COX. Is it a widely held stock?

Mr. SMITH. No.

Mr. COX. Do you publish periodically your balance sheet?

Mr. SMITH. We do not.

Mr. COX. Do you file a financial report either in the State of Connecticut with any State authority, or in the State of Delaware with any State authority?

Mr. SAFFORD. Only for tax purposes.

Mr. COX. Can you tell us in a very brief way what kind of statement that is?

Mr. SAFFORD. For Connecticut it is the tax required under their business tax law, and I think it gives the balance sheet and the income statement as sent to the United States Treasury.

Senator KING. I suppose you file the Federal tax report in addition to the ones to the State.

Mr. SAFFORD. Yes, sir.

Mr. COX. Do you know whether you file a similar report in the State of Delaware or not?

Mr. SAFFORD. It is not required.

Mr. COX. Aside from those, whatever may be contained in your return to the State of Connecticut and the return which you file with the Department of Internal Revenue of the Treasury Department here, there is no disclosure of your balance sheet or your income statement. Is that correct?

Mr. SAFFORD. That should be qualified further; that is, in each State where the corporation is qualified to do business there are certain tax reports which you must file.

Mr. COX. Will you tell us in how many States your corporation is qualified to do business?

Mr. SMITH. Seven or eight.

Mr. COX. And in those States you file whatever reports are required to be filed by law?

Mr. SAFFORD. Yes.

Dr. LUBIN. Do any of the States make those reports public?

Mr. SAFFORD. I don't think so, Dr. Lubin.

Mr. COX. No statement with respect to your company is contained in Moody's or Poor's or any of the other financial reports?

Mr. SAFFORD. No, sir.

Senator KING. Do the States treat your reports differently from reports filed by corporations doing business within a State?

Mr. SAFFORD. I think it puts us all in the same category. I think the figures are all confidential with the departments with which they are filed.

Senator KING. Who imposes confidentiality, if you permit that expression?

Mr. SAFFORD. It is under the statutes, sir, of the respective states.

Senator KING. You conform with the State practice and the State officials follow the State requirements?

Mr. SAFFORD. Yes, sir.

Senator KING. So if they are treated as confidential is it at your request or in pursuance of the law which the State officials follow?

Mr. SAFFORD. It is in pursuance of the law which the State officials follow.

Mr. COX. Now, Mr. Smith, I would like to ask some questions about the licenses under which your patents are used. You said this morning that you had patents on the feeding machines, the forming machines and the lehr or annealing machine, and I assume in the case of each of those machines, when your company licenses under the patent which applies to the machine, you retain title. Is that correct?

Mr. SMITH. That is correct.

Mr. COX. Do you have any patents on glass furnaces?

Mr. SMITH. We have.

Mr. COX. Did you ever license a glass furnace?

Mr. SMITH. We have not as yet.

Senator KING. Have you declined?

Mr. SMITH. No; we haven't the experiments completed.

Mr. Cox. So that in the case of a man who licensed from you feeding machines and his forming machines and the lehr or annealing oven, the only part of the machinery, used in manufacturing glass which he owns outright is the furnace. Is that right?

Mr. SMITH. In some cases, yes; in some cases, no. We have title to the actual machines we ourselves built and licensed, but in a number of other cases we haven't actual title.

Mr. Cox. Even though you have licensed those?

Mr. SMITH. Yes.

Senator KING. And accept royalties?

Mr. Cox. That is again a case where the machine is not built in the first instance by your company and licensed?

Mr. SMITH. Correct.

Mr. Cox. In some of those cases where the machine was not in the first instance built by your company you have at a later date acquired title and then licensed it?

Mr. SMITH. Correct.

Senator KING. You can't become a purchaser of the patent over a licensee of the patent?

Mr. SMITH. I beg your pardon.

Senator KING. Do you become a purchaser of the patent under which the machine was constructed or a licensee of the patentee? Perhaps I didn't make myself clear. I understood that there were some machines which you didn't make.

Mr. SMITH. Actually build. When the courts decide a suit in our favor, if the manufacturer had infringed and wanted to license, he could either take our own machinery or keep his machinery. In some cases he took our machinery; in other cases he kept his machinery.

Mr. Cox. In some cases where he kept his machinery you paid him a certain contribution for the title of the machinery?

Mr. SMITH. Yes.

Mr. Cox. In some cases you didn't buy title, he just took license?

Mr. SMITH. Yes.

Mr. Cox. There are two different kinds of charges you made in connection with the license, are there not, a license fee and a royalty charge?

Mr. SMITH. Correct.

Mr. Cox. The license fee is a lump-sum payment made either at once or in installments which is a contribution to you for granting the license?

Mr. SMITH. Yes.

Mr. Cox. The royalty fee, on the other hand, is a fee which is paid for the use of the licensed machinery?

Mr. SMITH. Correct.

Mr. Cox. And that royalty fee is on a quantity basis, isn't it?

Mr. SMITH. So much per gross, depending on the sliding scale, depending upon the weight of the article made.

Mr. Cox. Now taking up the license fees, in the first place can you, or Mr. Safford, tell us what the license fee is for the feeding machines?

Mr. SAFFORD. \$2,000.

Mr. Cox. And how long has it been \$2,000?

Mr. SAFFORD. I would say within 2 or 3 years.

Mr. Cox. Isn't it about 1936 that it changed from \$2,500 to \$2,000?

Mr. SAFFORD. Yes.

Mr. COX. Can you tell us what the license fee is for forming machines?

Mr. SAFFORD. \$8,000 for the four mold forming machines.

Mr. COX. And what is the license fee for the lehr?

Mr. SAFFORD. \$2,500.

Mr. COX. Do you have there a schedule of the royalty fees so we could avoid this? Just put it in.

(The schedule referred to was marked "Exhibit No. 114" and is included in the appendix on p. 763.)

Mr. COX. This is on the feeding machine, isn't it?

Mr. SAFFORD. Yes.

Senator KING. What was the answer to the question?

Mr. SAFFORD. Yes.

Mr. COX. If there is no objection, I should like to have this—

The CHAIRMAN (interposing). It may be admitted.

Mr. COX. Those agreements usually provide for the payment of a minimum royalty fee, don't they?

Mr. SMITH. Yes.

The CHAIRMAN. This is a list of royalty rates and not of license fees?

Mr. COX. That is right. As a matter of fact, we have a statement here which has been mimeographed, and which we might offer at this time, subject to check by the witnesses, showing the total gross amount received by way of royalties and license fees by the company for each year since 1923. This is a gross figure and does not represent a net income figure of the company. I would like to offer that subject to correction.

Mr. SMITH. That is all right.

The CHAIRMAN. It is not clear from the colloquy that has been going on at that end of the table whether this has been identified or not.

Mr. COX. It has been identified as having been prepared from statements which were furnished to us by the company, and I am now about to offer it, subject to correction if any arithmetical errors are found.

The CHAIRMAN. This purports to be a statement of receipts from royalties and license fees by the Hartford-Empire Co., from and including the year 1923 to 1937, both inclusive?

Mr. COX. That is correct.

The CHAIRMAN. It may be received.

(The statement referred to was marked "Exhibit No. 115" and is included in the appendix on p. 764.)

Senator KING. I would like to ask one question. I note that in 1923 the total received from royalties and license fees was \$766,534; in 1937, \$6,065,262. I am interested to ascertain whether or not that large increase in the licenses and in the royalties resulted from an increase in license fees and royalties, or was it an increase in production.

Mr. SMITH. Increase in the number of licenses. In '23 we had not established our patents; they had not been adjudicated. As our patents were adjudicated and established we took on more licensees each year, so that the royalty return came instead of from 15 or 20

licensees, from a great many more licensees. All told I think we had something like 86 licensees.

Senator KING. I understood from your testimony that the license fees or royalties were based in part at least upon production.

Mr. SMITH. All the royalties are based upon production.

Senator KING. Would any of this increase from \$766,000 to \$6,065,000 result from increased production?

Mr. SMITH. Oh, yes.

Senator KING. As well as from increased number of licensees and those from whom you were receiving royalties.

Mr. SMITH. Quite right. In some cases we have reduced the royalty rates.

The CHAIRMAN. I merely wanted to call the attention of the members of the committee to the fact that this morning we agreed to follow a rule of procedure which was originally suggested I think by Senator King, namely, that we would permit the Department to proceed with the original examination before asking our own questions. We are all violating this rule, Senator, but in the interest of orderly procedure it was felt it would be the best way to go along.

Senator KING. The Senator's statement is in part accurate but I will not challenge the inaccuracy.

Senator BORAH. Who is going to enforce the rule?

The CHAIRMAN. I shall attempt to ask the members of the committee to refrain.

Mr. Cox. While we are dealing with the matter of royalties and license fees, I should like to state that the Department has prepared a computation showing the percentage relationship between royalties and gross license fees, and the total gross income of the company from 1932 to date. This computation shows that the percentage relationship in 1932 was 91.2 percent; in 1933, 93.6 percent; in 1934, 96.2 percent; in 1935, 95.1 percent; in 1936, 93.7 percent; 1937, 94.5 percent. I am now going to give this computation to the witnesses so that they can check it, and we will make any corrections that may be necessary. I suggest that we do that over the evening, if that is convenient for you.

Mr. SMITH. I would be very glad to, if we could.

Mr. Cox. You may keep that, and we will make any corrections that are necessary.

Now to revert to the license agreements, those license agreements, aside from containing the provision requiring the payment of royalties, contain certain other restrictive provisions, do they not?

Mr. SMITH. Correct.

Mr. Cox. They contain restrictions as to the kind of ware which can be manufactured by the licensed machinery, is that correct?

Mr. SMITH. Correct.

Mr. Cox. Do you now have outstanding any license which is absolutely unrestricted so far as the kind of ware which may be manufactured is concerned?

Mr. SMITH. In the container field, I think we have two such licenses, two unrestricted licenses.

Mr. Cox. That is, strictly in the glass container field there are two licensees, and only two, who are free to manufacture any kind of ware they please with the licensed machinery.

Mr. SMITH. That is correct.

Mr. Cox. Could you tell us who those licensees are?

Mr. SMITH. The Owens-Illinois Glass Co. and Hazel-Atlas Glass Co., both of which companies do a national business, have plants located in various parts of the country, and also make, as they advertise, everything in glassware and containers.

Mr. Cox. The Owens-Illinois Co. is the largest manufacturer of glass containers?

Mr. SMITH. Yes.

Mr. Cox. And the Hazel-Atlas Co. is another very large manufacturer of glass containers?

Mr. SMITH. Correct.

Mr. Cox. But there is no license, even those licenses, which is absolutely unrestricted as to kind of ware which can be produced by the machines.

Mr. SMITH. I don't get your question.

Mr. Cox. Neither the Owens-Illinois Co. nor Hazel-Atlas is free under its license to manufacture heat-resisting ware, is that correct?

Mr. SMITH. That is true.

Mr. Cox. Or electric bulbs.

Mr. SMITH. That is true.

Mr. Cox. But those kinds of ware are, of course, not normally regarded as being in the glass container class.

Mr. SMITH. Correct.

Mr. Cox. And that kind of ware and several others are what is known in the trade as specialty ware.

Mr. SMITH. Specialty ware, and they are not allowed to make specialty ware.

Mr. Cox. And you have only one licensee who is allowed to make specialty ware, is that correct?

Mr. SMITH. Practically. You are talking about bulbs or heat-resisting ware. I am told by my partner that is not correct.

Mr. SAFFORD. I think if you apply the term "specialty" to all non-containers, then there are a great many more licensees than one.

Mr. Cox. I wasn't applying the term in quite that wide way, although my question perhaps was open to that kind of interpretation. I have in mind the specific kinds of classifications that are named in the contract between yourselves and the Corning Glass Works: Signal and optical ware, electric bulbs, and certain kinds of heat-resisting ware. As to those types of ware, you have only one licensee and that is Corning.

Mr. SMITH. Right.

Mr. SAFFORD. Except as rights have been released by the Corning Glass Works.

Mr. Cox. Except as they have granted sublicenses. That is a contractual relationship between Corning and others?

Mr. SAFFORD. No; they have permitted us to grant rights in those fields.

Mr. Cox. And in some cases you grant those rights with the consent of Corning Glass Works?

Mr. SAFFORD. That is right.

Mr. Cox. To return to the glass container field, you said a moment ago you had only two licensees who are absolutely unrestricted as to

types of ware they can produce. Are those two licensees also unrestricted as to the quantity of the different types of ware that can be produced on the licensed machine?

Mr. SMITH. Correct.

Mr. Cox. But they are the only two who are so unlimited?

Mr. SMITH. Correct.

Mr. Cox. All the other licensees are limited as to the amount or the number of glass containers that they can produce.

Mr. SMITH. Oh, no. They are limited to types of wares, but not to amounts.

Mr. Cox. Some of them are limited as to amounts.

Mr. SMITH. Some of them are, that is right.

Mr. Cox. Now taking for a moment milk bottles, you have before you the chart which we marked this morning.¹

Mr. SMITH. Yes; and if you don't mind, Mr. Cox—excuse me, I was talking about another chart. May I ask you a question about another chart? In this pamphlet which you submitted to the committee this morning on page 27,² graphically speaking it seems to me that 1 little bottle which is supposed to represent 500,000 gross doesn't tell what you really intend to have it tell, namely, that there ought to be 35 little bottles along the line as each concern produces 500,000 gross.

And again when you have divided, on page 23,³ packers' ware, medicine and toilet, liquor ware, milk bottles and beer bottles, the statistics which you used, I doubt whether they were quite complete and give graphically the real picture. Am I permitted to submit for your approval revised charts, like on the packers' field, and the 35 bottles? I think it would be rather interesting because on page 23 it is quite a different story from what this particular chart tells. In other words, you have packers' ware, and the records of the Container Association and our own records show that 26 percent of the industry goes into what you might call packers' ware; 30 percent in medicine and toilet; 16 percent in liquor ware; 5 percent in milk bottles; 2 percent in fruit jars; and 9 percent in beers.

Mr. Cox. We, I think, would be glad to have any other figures, so far as page 23 is concerned.

Mr. SMITH. It just shows a little different picture, that is all.

The CHAIRMAN. What does the chart on page 23 purport to show, Mr. Cox?

Mr. Cox. It purports to show the importance of the different kinds of ware, the numerical importance of the different kinds of ware in the entire glass industry. That is, it shows, for example, what part of glass containers are represented by the milk bottles produced, what part are represented by the fruit jars. The figures from which the chart was prepared were figures taken from the Census of Manufactures, they were the best figures we could get at the time we prepared the chart, but we would be only too glad to have any other figures that are more accurate.

Mr. SMITH. Thank you very much, because I am sure those are more accurate.

¹ "Exhibit No. 113," appendix, p. 762.

² "Exhibit No. 112," appendix, p. 736 at p. 761.

³ *Ibid.*, at p. 757.

Mr. COX. I would be glad to have this, which is Mr. Smith's revised figures for the chart on page 23, put into the record.

(The amended chart referred to was marked "Exhibit No. 116" and is included in the appendix on p. 765.)

The CHAIRMAN. It will be so inserted. This I take it is the same chart but the figures are changed.

Mr. SMITH. The figures are quite different, and the same way with this chart on page 27.¹ Graphically there should be 35 little bottles, 35 concerns, each making 500,000 gross. As a bottle represents 500,000 gross, there should be 35 bottles out in a line.

Mr. COX. I think that Mr. Smith's objection to the second chart is pictorial rather than statistical. Our chart was prepared to show the average production of each one of these companies here so that each one of the companies' position might be compared with each of the companies listed above. What Mr. Smith wishes to do it to put out here at the side little milk bottles or bottles which will indicate the lump production of all of the remaining 35 companies in its relation to the production of each of the other individual companies.

While I have no objection to this and will be glad to have it go in the record, I want to make it clear that this chart of Mr. Smith's shows quite a different thing. We were attempting to contrast the position of the single small manufacturer in the field with the five big companies, and Mr. Smith's figure here is a lump figure for all of those 35, a pictorial representation of the 35.

(The chart referred to was marked "Exhibit No. 117" and is included in the appendix on p. 766.)

The CHAIRMAN. With respect to this other chart, did you develop the source of the percentages marked by Mr. Smith?

Mr. COX. Where did you get your figures, Mr. Smith?

Mr. SMITH. From our own returns and the returns of the Glass Container Association.

Mr. COX. Published from time to time by the Glass Container Association?

Mr. SMITH. Yes.

Mr. COX. That is the trade association for the glass container industry.

Just so the record may be clear as to the relationship between yourself and Corning Glass Works, I want to make sure that I understand it is correct that before you can grant a license in one of the fields covered by the Corning contract it is necessary for you to get the consent of the Corning Glass Works.

Mr. SMITH. In the formation agreement of the Hartford-Empire Co. and the agreement with the Corning Glass Works made at the same time, we sold outright to the Corning Glass Works certain rights and inventions, including the right to license in those particular fields and wares, so it isn't in our hands. We sold the exclusive rights. If the Corning Glass Works came to us and said, "Will you license A, B, C, and D?" we would probably be glad to do so, but we have no right to license. We sold them that exclusive right. That is theirs to do with as they see fit. We have divested ourselves of all further rights in those fields.

¹ "Exhibit No. 112", appendix, p. 736 at p. 761.

Mr. COX. If I should wish to get the use of one of your machines to manufacture Pyrex then, I would have to go to the Corning Glass Works?

Mr. SMITH. Correct.

Mr. COX. If I came to you, you would send me to them.

Mr. SMITH. I would send you to them.

Mr. COX. Taking the chart¹ again, which is what I started on a moment ago, you testified that your licensees are restricted as to the kinds of ware that they can produce. Will you tell us how many of the licensees shown on this chart are free today to produce milk bottles?

Mr. SMITH. I think there are 10, although this chart may not show all of the various ramifications. Thatcher Manufacturing Co. have a subsidiary, the Olean Glass Co., which is also producing milk bottles. The Universal Glass Products Co. can produce milk bottles.

Mr. OLIPHANT. All kinds of milk bottles?

Mr. SMITH. Yes; all kinds; quarts and pints and creamers and specialties.

Hamilton can produce milk bottles; Liberty Glass; Lamb Glass Co. can produce milk bottles. Of course, the Owens-Illinois Co. can produce milk bottles; Hazel-Atlas Glass Co. can produce milk bottles. Florida Glass Co. can produce milk bottles. Buck Glass Co. can produce milk bottles.

Mr. COX. Now, can you tell me this, Mr. Smith: Of those companies you have named, how many can produce as many milk bottles in a year as they want to produce?

Mr. SMITH. The Owens can; Thatcher can; Olean could, and Liberty Glass Co. could. I think that is all.

Mr. COX. So that, counting Olean as a subsidiary of Thatcher, there are only three companies in the United States today who have a right, under their licenses from you, to produce as many as they like?

Mr. SMITH. Correct.

Mr. COX. The Thatcher Co. has a plant in Elmira, N. Y.?

Mr. SMITH. Correct.

Mr. COX. The Liberty Glass Co. has a plant in Oklahoma, doesn't it? Do you know what plants of the Owens-Illinois Co. produce milk bottles with your machinery?

Mr. SMITH. They have a plant in Columbus and a plant on the coast. I don't know whether they make any glass in the East here. They probably may at their Bridgeton plant. They have the right to make them in any plant they see fit.

Mr. COX. There is no territorial limitation on their right to make milk bottles?

Mr. SMITH. There are no territorial limitations on any of the people who make milk bottles.

Mr. COX. You spoke a moment ago of the Pacific coast. Is anyone licensed to produce milk bottles on the Pacific coast besides Owens?

Mr. SMITH. Owens and Hazel-Atlas.

Mr. COX. But that is a limited license.

Mr. SMITH. No.

¹ See "Exhibit No. 113," appendix, p. 762.

Mr. Cox. Limited as to quantity?

Mr. SMITH. Mr. Safford says it might be called a limited license, and I will accept his definition.

Mr. Cox. You said there were only three companies with the absolutely unrestricted right.

Mr. SMITH. Hazel-Atlas didn't originally have the right to make milk bottles. They asked consent to make a few on the coast and we gave it to them, but we didn't specify the number nor how the license should run.

Mr. Cox. It is a license at will?

Mr. SMITH. It can be canceled tomorrow if we see fit.

Mr. Cox. And they do make a few milk bottles.

Mr. SMITH. So I understand.

Mr. Cox. Now consider the fruit jars for a moment. Will you tell us how many licensees shown on the chart have the right to produce fruit jars?

Mr. SMITH. Three; Hazel-Atlas Glass Co., Owens-Illinois Glass Co., and Ball Bros.

Mr. Cox. Are any of those licensees restricted as to the number of fruit jars they can produce?

Mr. SMITH. No.

Mr. Cox. Those are all unrestricted licenses?

Mr. SMITH. Yes.

Mr. Cox. Without naming them, can you indicate generally how many of the licensees are licensed to produce packers' ware?

Mr. SMITH. I would say a great many, something like 34.

Perhaps the committee will be interested in getting to the bottom of this licensing policy.

Mr. Cox. I am going presently to ask some questions, Mr. Smith, that may assist you in that regard; if you don't mind, you might wait until then.

I think it might be helpful if at this point we put in the record one or two of these license agreements. I have one here for the Florida Glass Co., a certified copy which was taken from your files. You are satisfied, I assume, that that is a copy.

(The license agreement referred to was marked "Exhibit No. 118" and is on file with the committee.)

Mr. Cox. This license contract contains a provision which is, I think, perhaps indicative of some of the provisions which limit quantity. It contains a provision that the licensee may manufacture milk and cream bottles, "provided, however, that the licensee shall not produce in any calendar year on any and all feeders licensed to it by licensor more than 21,000 gross of such bottles."

Mr. SAFFORD. That has been amended, Mr. Cox. The amendment is in your license. That was raised at their request.

Mr. Cox. Can you tell me what the number is now?

Mr. SAFFORD. It is 27,500.

Mr. SMITH. That is due for some explanation, if I may make it.

Mr. Cox. I am perfectly willing to let you make any explanation you want to make. Is what you wish to speak about the provision contained in some of those with respect to increase in total production? If so, you go ahead and tell about that.

Mr. SMITH. Well, let's take the whole thing, Mr. Cox, after you finish. You go right ahead.

Mr. COX. Your licenses do contain provisions restricting the territory within which the licensee may sell?

Mr. SMITH. There is only one.

Mr. COX. Is that the Northwestern Glass Co.?

Mr. SMITH. Correct.

Mr. COX. I hand this to you, which is a certified copy of that license contract and ask you if you are satisfied as to the accuracy of it.

Mr. SAFFORD. That is for a very small plant in a limited area.

Mr. COX. I understand. Under this license he is permitted to manufacture ware which can be sold only in Oregon, Idaho, Montana, and Alaska. Is that right?

Mr. SAFFORD. Yes; I think so. That is the only limited territory.

Mr. COX. I should like to offer this.

Senator KING. Is that to be inserted?

Mr. COX. I have no interest in having it printed. I'd like to have it marked as an original exhibit and certified.

The CHAIRMAN. Is that true of "Exhibit No. 118"?

Mr. COX. Yes.

The CHAIRMAN. Both of these exhibits may be filed with the committee and certified as exhibits offered by the Department of Justice for the purpose of this hearing.

(The contract referred to was marked "Exhibit No. 119" and is on file with the committee.)

Mr. COX. Sometimes in your license agreements you specify the customers to whom the manufactured ware may be sold?

Mr. SMITH. No.

Mr. COX. Are you quite sure about that, Mr. Smith?

Mr. SMITH. I don't remember any such situation. Yes; I think there are only two such occasions.

Mr. COX. Well, the one I have here is the license to the Laurens Glass Works, Inc., Laurens, S. C., which reads as follows, or a letter which was attached as a rider reads as follows [reading from "Exhibit No. 120"]:

You are authorized to make under the said licenses a total of not over 4,000 gross per calendar year under both of said licenses, of panel bottles not exceeding 14 ounces in weight.

By the way, what is a panel bottle?

Mr. SAFFORD. It is a flat-sided bottle.

Mr. COX. [reading further]:

The said bottles are to be sold chiefly to the Globe Medicine Co. or to the Standard Drug Co., or both, both of Spartanburg, S. C. But you are also authorized, until further notice, to sell a part of such total of 4,000 gross per year to small users of such bottles in your vicinity.

That was one of the provisions I had in mind.

Mr. SMITH. You may find one or two or possibly three, but that—

Mr. SAFFORD (interposing). I don't want to interrupt the proceedings, but are you sure that wasn't subsequently revoked and embodied in a larger license?

Mr. COX. Not so far as we could tell.

Mr. SMITH. That comes about due to this fact. A licensee may be making packer's ware or some other field, and they occasionally bob up and say, "I have a friend over here and I have known him a long time. For heaven's sake, let me make 4,000 gross of prescription bottles for him. We don't want to go into the prescription business. We don't want to make that kind of ware, as a general thing, but just as a courtesy from Hartford let us supply that particular fellow.

Mr. Cox. You do it under those circumstances.

Mr. SMITH. Not as a general proposition, but every once in a while. We decide each case on its own merits. If it seems reasonable and a decent thing to do, we will expand his license so that he can take some particular advantage of some particular situation, but that isn't an intrinsic part of our general licensing.

Mr. Cox. It would be accurate to say, then, that in the cases where that kind of provision is in the agreement, what you have done is to carve out a limited exception to a prohibition against any manufacture of that kind of ware. Is that correct?

Mr. SMITH. No; not quite.

Mr. Cox. I thought that is what you said a moment ago, Mr. Smith.

Mr. SMITH. One particular man under a license may not have the right to make that particular line of ware because that wasn't his business; but if some particular situation arose where you might say, almost as a matter of courtesy, if he wanted to make just a small quantity of that particular line of ware for a particular concern, we say, "All right, go ahead," and we added that right to his license.

Mr. Cox. What I wanted to be sure of is this: As you explain it, it is a situation in which the man in the first instance under the license had no right to make that—

Mr. SMITH (interposing). He has no right because he has never been in the habit of producing that ware and his business wasn't in that particular line.

Mr. Cox. His license wouldn't let him make it?

Mr. SMITH. But as a general licensing policy, when a manufacturer came to us for license, we said, "What have you been making? What would you like the license for?" And we would give him the license to make the particular glassware that he was manufacturing, selling, and marketing.

Mr. Cox. I would like to have this go into the record to be marked as an exhibit. There has been a change in the quantity provision, Mr. Safford, but we found no provision in that I read, but I will correct it.

Mr. SAFFORD. Let it go in subject to check.

The CHAIRMAN. Do I understand that it is your desire to have this printed in the record or filed as the others were?

Mr. Cox. Filed as the others were.

The CHAIRMAN. I want to be sure of your desire.

Mr. Cox. I want to make my own position clear about that. I have no interest in burdening the record by having these things printed. On the other hand, I wish to be sure they are certified as exhibits so they can be used by the Department in connection with any report to be prepared.

The CHAIRMAN. Of course, it would be the desire of the committee to have a complete story told. Therefore, I am anxious that whenever you present these that you are satisfied in your own mind that you have sufficiently developed the character of the exhibit to make the record clear.

Mr. COX. I read or paraphrased the part of interest to the Department, and we are not interested in having the rest of it printed.

The CHAIRMAN. Very well, it may be admitted with that understanding.

(The contract referred to was marked "Exhibit No. 120" and is on file with the committee.)

Mr. COX. Now sometimes your licenses contain restrictions which may be made as to the use of the manufactured ware, do they not?

Mr. SMITH. Can you give me an example?

Mr. COX. Well, take the license which you have issued the Buck Glass Co. Isn't there a provision in there which authorizes them to manufacture wine bottles for sacramental wine?

Mr. SMITH. I think there is although I am not sure, but if there is such a provision, it is right along the line with what we just have been talking about. The Buck Glass Co. is not a wine house, not a liquor house, but they had a little extra business coming from somebody that wanted some wine bottles for sacramental wine. That may be in there. I assume it is if you say it is.

Mr. COX. That is what I am informed. Another example I have in mind would do with the Latchford Glass Co. I think they are licensed to manufacture bottles to be filled with milk of magnesia. I assume that under that license they can't manufacture bottles to be filled with any other kind of medicine.

Mr. SAFFORD. I think that is a descriptive term of the type of bottle rather than the use.

Mr. COX. I see. In other words, under that license they can manufacture a bottle of that type and it can be filled with any kind of medicine.

Mr. SAFFORD. That is right.

Mr. COX. Tell me this: Under your license agreements, some of your licensees are entitled to manufacture packers' ware. There is a kind of jar which fits into the packers' ware category which is comparable to a fruit jar in size and shape, is it not?

Mr. SMITH. They are very much alike.

Mr. COX. When you license a man to produce a bottle of that kind for use for packing food products by processing food products, do you regard it as a violation of the license agreement if he uses the bottle to preserve fruit?

Mr. SMITH. The license we extend to the manufacturer is to make certain lines of bottles; what those bottles are used for determines the kind of the license. Now if a man were making ordinary packers' jars and a jar goes to the producing manufacturer of food products they use that jar and put their own products up in that jar. The manufacture of fruit jars for the domestic household trade is an entirely different kind of business, and the licensee who had the right to make the packers' jars would not have the right to make fruit jars for household domestic trade. Does that answer your question?

Mr. Cox. I think it does with one exception. I want to make sure that I understand what you mean by that. If such a licensee should manufacture a packers' ware jar and begin selling it for use as a fruit jar, would that be a violation of his license?

Mr. SMITH. It would.

Mr. Cox. Now the licenses which you have which you issue on some of your machines, and I am speaking now particularly of the lehr or annealing oven, contain a provision which restricts use of the licensed machine, or in connection with other machinery which is patented by you and licensed to the licensees, do they not?

Mr. SMITH. That was true at first, but that is no longer in force.

Mr. Cox. Now, what I have specifically in mind is a provision which I found, which I shall hand to you in a moment, in the agreement, the license agreement, with Whitall Tatum Co. The agreement was made in 1933, containing this provision [reading from "Exhibit No. 121"]:

The said leased machines are designed, developed, and adapted especially for use with other glass machines controlled by the licensor. The grant of rights herein to use such leased machines and to use the said patent rights therein embodied is therefore restricted and limited as follows: In case the said leased machinery shall at any time be used by the licensee for the annealing or treatment of glassware produced by the aid of any feeding machinery not then controlled or under license from the licensor, and such use shall continue after the licensee shall have received from the licensor written notice of objection to such use, then in such case the licensor reserves the right, in its option, to revoke and cancel this license and lease, upon paying to the licensee the amount of 1 year's minimum royalty hereunder.

Mr. SMITH. That was in our early contracts and since has been changed and was never enforced. I think we started out with the idea that we wanted to have the use of our equipment tied to our own forming machines and feeders.

Mr. Cox. Has that particular provision in that particular license agreement been changed? Can you answer that?

Mr. SAFFORD. No.

Mr. Cox. So under that agreement as it stands today Whitall Tatum Co. cannot use the lehr except in connection with your machinery, is that right?

Mr. SAFFORD. That is not quite correct.

Mr. Cox. I realize that; I put it this way. If it does, it then brings into operation the right to cancel which is provided by that contract.

Mr. SAFFORD. That is not quite true. It is merely we reserve the right.

Mr. Cox. You can cancel that contract.

Mr. SAFFORD. But until we exercise it, they have the right to use the machinery with another.

Mr. Cox. But if they use the machinery with others, you have the right to cancel that upon payment of 1 year's royalty.

Mr. SAFFORD. That is correct.

Mr. Cox. Is this same provision in effect in many other existing contracts today under lehrs?

Mr. SAFFORD. It is not in the latest edition of the standard contract and it is probably in all editions prior to that.

Mr. Cox. When was that change made?

Mr. SAFFORD. Well, this is the edition of May 1936, that I have here that doesn't contain that provision.

Mr. Cox. You think probably until that time the provision was contained in these lehr contracts?

Mr. SAFFORD. Yes.

Mr. Cox. Can you tell us, Mr. Smith, why the company decided to abandon that provision?

Mr. SMITH. No, necessarily some legal reason. I will have to refer to my legal staff. In fact, I didn't know it had been abandoned.

Mr. Cox. Do you have any opinion on that, Mr. Safford?

Mr. SAFFORD. I think it is a legal conclusion, namely, that the combination of the lehr and the feeder had no reasonable relation from the manufacturing point of view and, inasmuch as we had no patents covering the combination of the two, it was thought advisable to omit the provision.

Mr. Cox. Well, if I should suggest that you might and did abandon it because you had reason to believe that it might present some question as to whether or not such an agreement was prohibited by the antitrust laws, would you deny that?

Mr. SAFFORD. I don't think we'd deny that.

Mr. Cox. That is one case where the the antitrust laws may have had such an effect. I'd like to have the contract marked, if I may, and treated the same way as the others.

The CHAIRMAN. It may be so marked.

(The contract referred to was marked "Exhibit No. 121" and is on file with the committee.)

Mr. Cox. Under these license agreements, the agents or employees of your company, of course, have a right to go on the premises of the licensee at reasonable times to make reasonable repairs?

Mr. SMITH. Correct. In fact, they are quite welcome.

Mr. Cox. You attach a plate on each of your machines, do you not, Mr. Smith, stating that the machine is licensed under certain patents and giving the numbers?

Mr. SMITH. Correct.

Mr. Cox. And from time to time as new patents are issued, you add numbers to the plates, is that correct?

Mr. SMITH. Correct.

Mr. Cox. Do you have the latest standard form of your stacker and conveyor agreement there, Mr. Safford?

Mr. SAFFORD. Yes; I have.

Mr. Cox. May I see it?

Mr. SAFFORD. That is the stacker.

Mr. Cox. You don't have it consolidated? Has this form been abandoned by your company?

Mr. SAFFORD. Well, that agreement is just with the one company, owing to the number of machines involved.

Mr. Cox. I see; that is not in common use.

Mr. SAFFORD. That is not in any use at all except with that one company.

Mr. Cox. This contract¹ contains a provision similar to the provision which I read a moment ago in the Whitall Tatum contract. In fact, it appears at first sight to read word for word with it and restricts the use of this equipment to use in connection with other ma-

¹ Referring to "Exhibit No. 122."

chinery which is covered by patents owned by your company and licensed by your company. Has that provision been modified or changed in this contract? That is, in section 5.

Mr. SAFFORD. No; that has not been changed. It would fall in the same category as the lehr situation. It is not used in the standard contract.

Mr. Cox. But this particular provision in this particular contract is still in force?

Mr. SAFFORD. Yes; I might add this one further thing, Mr. Cox, that I believe that we base that upon the fact that certain of our patents relate to the combination of the stacker with the lehr.

Mr. Cox. If that is so, why did you take it out of your standard—this is only the stacker and the lehr?

Mr. SAFFORD. That is right.

Mr. Cox. There is no such claim made with respect to the lehr and the feeder?

Mr. SAFFORD. That is what I explained before.

Mr. Cox. So the record may show what this document is, it is a consolidated stacker and conveyor agreement between Hartford-Empire Co. and Owens-Illinois Glass Co. The provision which I referred to is found in section 5, and appears to be in precisely the same language as the restrictive provision as was found in the Whitall-Tatum contract.

The CHAIRMAN. Do you care to read the provision?

Mr. Cox (reading from "Exhibit No. 122"):

The said leased machinery is designed, developed, and adapted especially for use with glass-annealing lehrs controlled by the licensor. The grant of rights herein to use such leased machinery and to use the said patent rights therein embodied, is therefore restricted and limited as follows: In case the said leased machinery shall at any time be used by the licensee for the handling of glassware, into, upon, or in connection with any lehr or other glass annealing machinery not then controlled or under license from the licensor, and such use shall continue after the licensee shall have received from the licensor written notice of objection to such use, then in such case the licensor reserves the right, in its option, to revoke and cancel this license and lease.

(The agreement referred to was marked "Exhibit No. 122" and is on file with the committee.)

Mr. Cox. Now, Mr. Smith, I should like to ask you some general questions in respect to your licensing policy, and I hope you will remember, as I am sure you will, as I ask these questions, that I have no intention of criticizing you personally or injecting what I might call the moral element into this investigation. I am merely interested in finding out why you follow certain policies. I take it, in the first instance, that you do not treat all of your licensees alike. That is obvious from the answers to the questions you have already given.

Mr. SMITH. You mean that they all don't have the same kinds and types of licenses?

Mr. Cox. That is right.

Mr. SMITH. Yes, that is right.

Mr. Cox. Now how do you decide exactly how you are going to treat a licensee?

Mr. SMITH. The manufacturer who hasn't been a licensee with Hartford asks for a license. There is something he would like the license for. We ask what use he desires to make of our machine.

He says, "I am in this kind of a business. I am in the prescription business, make some packers, make a few beers, and something of that sort." "And that is what you want a license for?" "Yes." And he gets it.

Mr. Cox. Now do you want us to understand, Mr. Smith, that you always give the petitioning manufacturer a license to produce all the kinds of ware he wants to produce?

Mr. SMITH. Not all the kinds of ware he wants to produce, but all the kinds of ware, generally speaking, that he is then producing. In other words, we have got to furnish him equipment which will satisfy his business needs. Now there are very few of the companies that make all kinds of ware. Many of the companies do a national business from coast to coast. Many are quite satisfied if they get a license from us to make three or four kinds of ware which is in a business that they know, their sales organization know, their producing organization know, their merchandizing organization know, and that is the license we give them and that is generally true. There may be one or two exceptions which I am not conscious of, don't know about.

Mr. Cox. You wouldn't go so far as to say in every case you'd grant a license to permit the man to manufacture everything he is manufacturing.

Mr. SMITH. Pretty near.

Mr. Cox. Pretty nearly that?

Mr. SMITH. Yes; that is the general policy. You will find exceptions to every policy, of course.

Mr. Cox. Then if the man comes to you and says that he has been producing packers' ware hitherto and he wants to keep on producing packers' ware, but he thinks he might do pretty well in the milk bottle business, although he has never made or sold any milk bottles, will you give him a license in that?

Mr. SMITH. Probably not, due to the fact that the producing capacity for manufacturing milks is way in excess of the consumption. In other words, out of our licensees, those 9 or 10 that have the right to produce milk bottles, they used our equipment something like 62.7 percent of the time. They didn't have the business to fill it up. Now if the manufacturers couldn't supply milk bottles to the trade, that would be an entirely different situation. We'd probably take on new licensees.

Mr. Cox. Well, in taking the situation which you described a moment ago where, in your opinion, the capacity of the industry to produce milk bottles is in excess of the demand of milk bottle supply—

Mr. SMITH (interposing). There is no question about that.

Mr. Cox. In a situation of that kind you would not grant a licensee the right to produce milk bottles?

Mr. SMITH. No. If you had made a large investment in our equipment and had been a good licensee and paid us quite a large sum of money each year and I came along to you and I said, "Mr. Cox, I have got a half million or a million dollars to devote to the manufacture of milk bottles," and you wanted to build a plant right at the back door of the licensee of the Hartford-Empire Company who had served and served us for a number of years, we'd probably de-

cline to give you such license; but, on the other hand, if the capacity couldn't look after the normal demand, so that people were suffering and couldn't get milk bottles, then we'd probably welcome you as a licensee.

Let me say, Mr. Cox, all those questions—we decided to take up one thing at a time, when the problem arises, and you might have a situation 2 years from today that was entirely different than a year from the present time. We reserve judgment, but, generally speaking, when the producing capacity is way in excess of consumption, we do not and would not grant licenses.

Mr. Cox. The effect of that kind of a policy is to protect the existing manufacturers of milk bottles from competition, from newcomers in the field, is it not?

Mr. SMITH. No; I don't like you to put it that way. It is to protect the present manufacturers, to make money, and to produce milk bottles cheaper.

The CHAIRMAN. That is a sort of A. A. A. in milk bottles. [Laughter.]

Mr. SMITH. Not so far from it, but used intelligently. [Laughter.]

Mr. ARNOLD. You think that kind of power is better in private than in public hands to decide capacity?

Mr. SMITH. I don't think there is any question about it, Mr. Arnold. Who is better able to say whether we shall have 1,000 licensees or 500 or 200 or 50? We know the trade. It is our lifeblood to keep in touch with the manufacturers and to find out what they need, to develop machinery for them, to really keep competition going, if you want to put it that way.

Mr. ARNOLD. Whereas agriculture doesn't know agriculture so well?

Mr. SMITH. I am sorry. I don't want to get into that.

Mr. Cox. I'd like to ask you a question about that. A man comes to you and asks for the right to make milk bottles and you point out to him that the capacity in the industry is already greater than the demand for milk bottles.

Mr. SMITH. Correct.

Mr. Cox. And he says, "Well, that may be but I can still make and sell better milk bottles and I can sell them cheaper than anyone else can, and I want to go into the industry." Then you say, "No; you can't do that."

Mr. SMITH. Of course, that is a hypothetical question, and I doubt whether he could prove he could make milk bottles cheaper and serve the public as well as the people who now make a specialty of producing milk bottles. It is not a cinch to produce milk bottles. The requirements are severe and the manufacturers are all the time working to give the public a better, stronger milk bottle, and that means cheapness, because a milk bottle today has 35 or 40 trips. If the manufacturer can produce a milk bottle that has 60 or 70 trips, it means less money. Of course, in Scotland, they use a milk bottle 100 trips, you know. [Laughter]

Mr. Cox. I expect that, Mr. Smith, but anyway you demand that your company be the agency which makes the decision as to whether a man—

Mr. SMITH (interposing). As to whether a man can use our machinery.

Mr. Cox. If he doesn't use your machinery, he is going to have a hard time.

Mr. SMITH. No; he can go ask for a suction machine. He can build a suction machine under the early patents. He can import suction machines. We went over that this morning.

Mr. Cox. You are not seriously now suggesting to us, Mr. Smith, that a man could take Mr. Owens' early suction machine and compete in the market today, the unimproved suction machine?

Mr. SMITH. Well, I don't know. I would say it would be difficult unless he had certain local conditions.

Mr. Cox. If that were true generally, I don't see what your licensees are paying royalties to you for. They might as well all begin using suction machines.

Mr. SMITH. They would prefer to use our machines.

Mr. Cox. I think they would undoubtedly and I doubt very much, Mr. Smith, whether a suction machine would be a commercially practical operation today.

Mr. SMITH. I don't think it is the best, but he can do that. You asked me whether he could do it. I don't want to do it. Does that answer your question?

Mr. Cox. Do you or Mr. Safford or any one in your organization know of any place in the United States today where they are producing glass containers on an unimproved Owens' suction machine of the kind used between 1904 and 1920?

Mr. SMITH. I don't know unless it may be the Ball Bros.

Mr. PARHAM.¹ Ball Bros. is doing it today.

Senator KING. Mr. Cox, you are not trying to support the thesis that there is to be no further improvement in the matter of glassware or anything else?

Mr. Cox. No; I am not. I was simply trying to develop a point which I believe to be true. If you or I or anyone else wants to go into the business of manufacturing glass today in this country there is only one place we can go to get machinery, and when we go there, they are the ones to decide what we can make and how much. I am not suggesting, sir, that it is improper or illegal, but I am trying to bring that fact out.

Senator KING. You are not suggesting that somebody else might provide better machinery.

Mr. Cox. I don't know. I have no power to look into the future; I only know what the situation is today. I think it is quite possible somebody in the future might develop it.

Mr. PARHAM. I think someone has already.

Mr. Cox. Whatever the foundation is for your decision which you make in respect to whether or not a person shall have a license to produce milk bottles, or fruit jars, either, as far as that person is concerned and your machinery is concerned, it is a final decision.

Mr. SMITH. Correct, as far as our machinery is concerned, it is a final decision—we either say yes or no.

Mr. Cox. Unless he can find some other machinery somewhere, he can't manufacture milk bottles.

Mr. SMITH. Not at present. Things change from time to time. We originally had, I think, 14 milk bottlers all told we have given out

¹ Sidney F. Parham. See testimony beginning *infra.*, p. 436 et seq.

and we try to look after these manufacturers. For instance, we gave in the Florida Glass license, a little fellow, the right to make 21,500 gross. As time comes along, he comes up and says, "Well, I think I can do a little more business in the territory. Will you extend the license rights?"

Yes, we have done it. He now has the right to make 27,500.

Mr. Cox. What consideration do you take into account when there is a request of that kind made to you? Do you always grant it?

Mr. SMITH. Not always, no; it all depends upon conditions existing at that time.

Mr. Cox. What conditions?

Mr. SMITH. We rather like to grant those extensions when the conditions or the situations warrant.

Mr. Cox. What conditions particularly do you have in mind?

Mr. SMITH. Well, I can't tell you, Mr. Cox. There may be 10 or 15 different reasons that affect it.

Mr. Cox. In determining what the character of these provisions of your license agreements is, Mr. Smith, do you make any attempt to delete or control competition among your various licensees?

Mr. SMITH. Well, I would say yes and no. What is the question, I mean?

(The question was reread by the reporter.)

Mr. SMITH. Imagine a situation of this sort where two licensees serve a certain radius and one licensee comes and wants an extension of rights or wants to produce a larger quantity of bottles, and if we thought that it was inadvisable to give him that extension, we wouldn't. Again we take those things up as they come along and try to decide each case on its merits. We are not always right. I don't know anybody who is always right. We have made some mistakes.

Mr. Cox. One of the circumstances which you would take into account in considering that question is as to whether there was some other manufacturer serving that particular territory with the same kind of ware.

Mr. SMITH. I think so. It would be a natural thing. It is a question of their both living or both being prosperous, not getting at each other's throats. We want to have them have steady business, steady employment, and we have found a lot of memorandums where I talked about stabilization, that is what I mean, not great fluctuations in industry, where our licensees can manufacture steadily, day by day and week by week and month by month and give employment to labor on a steady basis.

Mr. Cox. To the extent—

Mr. SMITH (interposing). In other words, to try to promote a healthy situation.

Mr. Cox. To the extent that competition among various manufacturers did not produce stabilized conditions of that kind, but resulted in price wars and wild fluctuations in price, you would think it wasn't a healthy thing?

Mr. SMITH. I don't think we have ever gone into price wars. We have nothing to do with what a manufacturer gets for his goods, to whom he sells, at what price he should sell. As a matter of fact, we don't know how he does merchandise his goods. I couldn't tell you the names of the customers of our licensees, or the prices they

get, or under what conditions they sell, or what territory they serve. But when they come to output, and ask for a certain right and a certain extension, that whole question as to whether they can produce that and add to their use of the machines, or machinery, so that it might be to the disadvantage of somebody else, I think probably we make up our minds then and there either yes or no. I can't give you any general rule, Mr. Cox, because we haven't any.

Mr. Cox. When you spoke a moment ago about stabilization, did you have in mind any such thing as stabilization of price?

Mr. SMITH. No; we haven't anything to do with prices.

Mr. Cox. Did you have in mind any such thing as stabilization of the part of the total quantity of glass containers produced in terms of any particular individuals?

Mr. SMITH. No.

Mr. Cox. You have no interest in seeing that a particular manufacturer preserves his present position?

Mr. SMITH. Not as regards his particular position in the industry, but preserves his financial condition so that he can continue to pay us royalties.

Mr. Cox. To the extent that competition might weaken his financial condition so that he couldn't pay you royalties, you are not interested in competition?

Mr. SMITH. No; not a bit. We don't care where he sells his goods, what prices he gets for them, the terms he gets. We can't tell you.

Mr. Cox. You wouldn't say that you were absolutely indifferent to competitive conditions in the industry, would you, Mr. Smith?

Mr. SMITH. Oh, in general, insofar as it might affect the soundness or might help the licensee; our income comes from the manufacturer. If a manufacturer can't make money he isn't going to be able to use our equipment, therefore he isn't going to pay us royalties. But what he does with the ware he makes on our machine is none of our business. We have never followed that up.

Mr. Cox. But you think that it is quite proper, do you, Mr. Smith, for you to use your patents and the rights thereunder to stabilize the glass container industry in the way you have described to us?

Mr. SMITH. Stabilized so far as the use of our machinery goes, not so far as their business goes, because we have nothing to do with their business.

Mr. Cox. Well, so far as your machinery relates to the manufacture of glass containers—

Mr. SMITH (interposing). Anything that will keep the manufacturer producing at a low cost, and at the same time bring us the return in royalties, we are interested in.

Mr. Cox. Those things are sometimes a little inconsistent.

Mr. SMITH. I know.

Mr. Cox. Of course, the cost might be lower if they didn't pay you any royalties at all.

Mr. SMITH. If they didn't pay royalties they wouldn't have our equipment and they would be out of business.

Mr. Cox. Well, that is the first time today I have been able to get you to admit that if they didn't have your equipment they would be out of business.

Mr. SMITH. If we withdraw our equipment they have to go somewhere else.

Mr. Cox. They have to go out of business, is what you said a moment ago.

Mr. SMITH. Well, this is a very intricate business and when we say we are working for our licensees it is literally true. We are working for them and we are working for ourselves, and we try to keep them at a competitive cost. We are continually supplying means and methods so that they can increase their production with the equipment which we have.

Mr. Cox. Mr. Smith, I am going to show you a memorandum which we took from your files dated March 26, 1928, entitled, "Memorandum as to Hartford-Fairmont and Hartford-Empire History and Policy,"¹ and ask you if you will identify that as a document which was in fact taken from your files.

Mr. SMITH. This is a memorandum which I assume was written by Mr. Herbert Knox Smith. His initials are on it, on the typewriter. What date was that?

Mr. Cox. This is March 26, 1928.

I want to call your attention to the following statement which is found in this memorandum [reading from "Exhibit No. 124"]:²

Consequently we adopted the policy which we have followed ever since, of restricted licenses; that is to say, (a) We licensed the machines only to selected manufacturers of the better type, refusing many licensees who we thought would be price cutters; and (b) we restricted their field of manufacture in each case to certain specific articles with the idea of preventing too much competition; (c) in order to retain more complete control of the situation, we retained title to the machines and simply leased them for a definite period of years, usually 8 or 10 years, with the privilege of renewal for a smaller additional term.

The CHAIRMAN. Mr. Cox, before you propound the question, may I ask, for the benefit of the record, to whom the word "we" applies or refers?

Mr. Cox. I take it the word "we" applies to the Hartford-Empire Co. The memorandum is entitled "Memorandum as to the Hartford-Fairmont and Hartford-Empire History and Policy. I understand it was written by Mr. Herbert Knox Smith, to whom he referred this morning.

The CHAIRMAN. And it has been so identified by the witness?

Mr. SMITH. I think there is no question about that, Mr. Chairman. His initials are on it. He had a habit of writing, every once in awhile [laughter] dissertations which always more or less clarified certain things in policy, looking 'way ahead of here. Every once in awhile he would sit down and review things and see how far off the track you may be, and how well on the track.

The CHAIRMAN. If I may be permitted to make an observation, I should say he had a very lucid style.

Mr. Cox. I had no difficulty in understanding the passage I read.

Mr. SMITH. A very remarkable man; very remarkable.

Mr. Cox. That, in fact, was the policy of the company.

Mr. SMITH. Not necessarily.

Mr. Cox. Do you suggest that Mr. Smith was wrong?

Mr. SMITH. Let me read it again.

This isn't so bad as you are making out, Mr. Cox.

Mr. Cox. I am not making anything out.

¹ Subsequently entered as "Exhibit No. 124," see appendix, p. 768.

² *Ibid.*, at p. 769.

Mr. SMITH. We had a restricted policy for fields of ware. It is true in those earlier days that we were more anxious to obtain as licenses the most financially strong concerns, and it is true that we restricted, in those early days, when we felt that the industry was overproduced, in various lines of ware. All of that is true, as I have previously told you.

Mr. Cox. You think that is all right; it is just the way I read it, perhaps.

Mr. SMITH. I don't think it tells the whole picture or gives the whole reasons for certain policies. I think I could do as well, almost, if I had time.

Mr. Cox. I am sure you could.

I want to ask both you and Mr. Safford another question. I want you to consider it very carefully and give me your answer, and then I think I shall leave this topic.

Is it your considered position now that you have no interest in price cutting in the industry, and that you never take any action to discourage that sort of activity?

Mr. SMITH. I would say "yes," Mr. Cox.

Mr. Cox. With no qualification?

Mr. SMITH. Yes; I will make a qualification. A licensee may come to me, after a year and a half or 2 years, and say: "My heavens, licensee No. 87 is pretty bad. He is selling below cost. Can't you do something about it?"

I will say: "Why, no; of course we can't do anything about it; we have no control over that licensee." But the next time I happen to meet the president I may say to him, "Why, Bill"—Dick, Tom, or Harry—"you know So-and-so is kind of disturbed. He thinks your prices are kind of bad." And that is all. We have no power over prices, we don't follow them, we don't know what people are charging. I couldn't tell you what a gross of bottles sells for today.

Mr. Cox. Mr. Safford, do you recall a man named Searcy who apparently lives in San Antonio, Texas?

Mr. SAFFORD. That is right.

Mr. Cox. Who is Mr. Searcy?

Mr. SAFFORD. He is an attorney who has represented us on various occasions.

Mr. Cox. Before I started this I should have asked: Did you concur in the answer I have just had from Mr. Smith?

Mr. SAFFORD. I do.

Mr. Cox. I am going to hand you what purports to be a copy of a letter which you wrote to Mr. Searcy on August 26, 1932, and ask if, in fact, you wrote such a letter to Mr. Searcy.

Mr. SAFFORD. Mr. Cox, the company referred to in this letter is the Three Rivers Glass Co.

Mr. Cox. Perhaps, before we go into that, I should have the letter back, because it is a little hard to tell what we are talking about. This letter is dated August 26, 1932, addressed to S. S. Searcy, attorney at law, San Antonio, Tex., and I understand it was a letter which you wrote.

Mr. SAFFORD. That is correct.

Mr. Cox. The passage to which I particularly call Mr. Safford's attention, and which he is about to explain, I hope, is a passage which reads as follows [reading from "Exhibit No. 123"]:

Three Rivers Glass Co. has been a perpetual thorn in the side of all the manufacturing companies. It won't assist the other manufacturers in any manner in maintaining general price levels. It isn't because they are more efficient than anyone else (which is a justifiable reason, of course, for lowering the price), but because they are just simply selling at an actual loss in order to stay in business.

We should like, for reasons of the general commercial situation and also because we feel there is no hope of Three Rivers ever paying us as they should, to take the machinery out of their factory.

Mr. SAFFORD. Well, that statement, that letter, was written to Mr. Searcy as our attorney. If I recollect, the Three Rivers Glass Co. was well behind in its royalties. It had started as a real-estate proposition and had pretty nearly lost money from the start. I don't know how much in royalties the Hartford-Empire Co. lost as a result of that, and several times when we examined statements supplied by that company, it was apparent from the face of the statements that they were selling below cost.

Mr. Cox. You did take the machinery out of their factory?

Mr. SAFFORD. We took the machinery out of their factory, but before that they were in bankruptcy.

Mr. Cox. But they were still manufacturing glass?

Mr. SAFFORD. That is a funny thing, Mr. Cox. We got the court order for the withdrawal of our machinery. I think that was in the winter of 1933, and they asked us if they could continue and use that machinery during the winter. Even at that time we saw no possibility of collecting royalties, but we allowed the machinery, as I recollect, to operate for 2 years more in order to keep up the employment, and I have forgotten in the end how much we failed to collect in royalties.

Mr. Cox. Now, what I would like to ask you is this, Mr. Safford—you say "for reasons of the general commercial situation" you should like to take the machinery out of the factory: What did you mean by that?

Mr. SAFFORD. I have no recollection.

Mr. Cox. If I suggest to you what you meant by that, they were selling glass, as you state in the letter, at cut prices, would that refresh your recollection?

Mr. SAFFORD. They probably were selling below cost.

Mr. Cox. And you wanted to put a stop to that situation.

Mr. SAFFORD. Not necessarily, but they always were a low-price house—probably selling below cost. Their freight differentials were over 16 percent at all times, the average for the industry being 8 or 9, so some place they were taking up those freight allowances, and we always felt they were selling far below cost.

Mr. Cox. You had been suspicious of them on that ground for some time.

Mr. SAFFORD. Our royalties were behind. We naturally went into their financial situation rather carefully.

Mr. Cox. Was it your royalties you were thinking of?

Mr. SAFFORD. I think that was part of the picture; yes.

Mr. Cox. And price levels at which other manufacturers had to compete had nothing to do with it?

Mr. SAFFORD. It probably had something to do with it; yes.

Mr. Cox. I should like to offer this letter in its entirety and have it printed.

The CHAIRMAN. It may be received and printed.

(The letter referred to was marked "Exhibit No. 123" and is included in the appendix on p. 767.)

The CHAIRMAN. Mr. Cox, did you offer for the record this document entitled "Memorandum as to Hartford-Fairmont and Hartford-Empire History and Policy"?¹

Mr. Cox. Yes; I would like to offer that, and I would like to have that printed.

The CHAIRMAN. Without objection, it is so ordered.

(The memorandum referred to was marked "Exhibit No. 124" and is included in the appendix on p. 768.)

Mr. Cox. May I inquire how long we are going to sit this afternoon?

The CHAIRMAN. The practice will be to sit until 4 o'clock every afternoon.

Mr. Cox. Mr. Smith, you testified that certain of these licenses contain restrictions as to the amount of ware that might be produced with this machinery. What considerations have you taken into account in determining the amount of a particular line of ware which a licensee may produce?

Mr. SMITH. Those licenses that you call attention to, Mr. Cox, are very few and far between. It is not a real picture of a general licensing policy. Very few licenses have those restrictions as to the amounts of ware. A great many have restrictions as to kinds of ware, but not so many of that. For instance, we have 34 licensees in food, 31 in prescription and proprietary, 31 in liquors, 26 concerns making perfumery and toiletry, 27 pressure beverages, 32 beers, and so on down the line, so the restrictions that you have specifically called attention to really are not the general policy.

Mr. Cox. Those numbers you read to us are unrestricted as to quantities?

Mr. SMITH. Unrestricted as to quantity. I take that back. Most of them are; not every one.

Mr. Cox. They have an unrestricted right so far as the field of ware is concerned with respect to the field of ware which you read, but they are not unrestricted in many instances as to quantity; is that right?

Mr. SAFFORD. In some instances.

Mr. Cox. Now, you have told us when a man wishes a license, as I understand it, the test in determining what field of ware a manufacturer may enter is what his business is when he applies to you for license. Do you have any same general test which you apply so far as quantity is concerned?

Mr. SMITH. No; I don't think so. I am not conscious of any. If they come along and want the license, the question is, What have you been making? What is the title of your business? What part of the industry do you serve? What customers must you produce for? Do you sell food containers, or do you sell perfumery containers, or do you sell the liquor trade, or do you sell beers and so forth; and gen-

¹ See supra, p. 417.

erally speaking, they got what they wanted; not in every case, of course, but generally speaking.

Mr. Cox. Do you inquire at the same time as to the quantity of the particular line or ware which they have been producing?

Mr. SMITH. Not as a general rule. Sometimes, yes.

Mr. Cox. Why do you put those quantity restrictions in at all?

Mr. SMITH. Well, if you could give me a case, I think I could explain it.

Mr. Cox. Take the Florida Glass Co.

Mr. SMITH. The Florida Glass Co. infringed our rights, they lost their suit, and they came to Hartford; and their president said he wanted certain rights, and we had a discussion in regard to those rights—what he should have—and finally we thought that plus other rights we had given him, 21,000 gross of milk bottles would satisfy him. He went along and came back and said, "I would like a little more."

"What is it that you really think you need down there?"

"I would like 27,500."

And he got it, and if he came along tomorrow or the next day and said he needed a little larger quantity, we would probably give it to him.

Mr. Cox. What I am interested in is why you put any quantity restriction in in the first place.

Mr. SMITH. Because if you didn't, you would at once be giving that man an asset which he might or might not use, and if you give him an unlimited right in that particular case it might prove very valuable to a lot of other people, stronger concerns that might go and buy him up. The Florida Glass Co. didn't guarantee to use extra machines to make the given number of bottles. Our license was to give him sufficient rights in order that he could live and make a profit.

Mr. Cox. Why are you interested in preventing a situation where someone else might buy him up?

Mr. SMITH. I think when you just give everybody everything they want, whether they are going to use it or not, you might not have such a sound industry.

Mr. Cox. You think it would be an unhealthy industry if every manufacturer could use everything he wanted to?

Mr. SMITH. To use everything he wanted, at every time, I think would be quite undesirable and unhealthy for the industry.

Mr. Cox. Why do you think that?

Mr. SMITH. Because I think you would have retaliation to a very great degree.

Mr. Cox. What do you mean by that?

Mr. SMITH. A man would attempt to make things he wasn't really fitted to make, he wouldn't produce as good ware, he wouldn't produce ware as economically. The extra costs and the extra expense of producing ware at the lowest possible price would be seriously affected. And then again, as I understand it, the different fields of ware require different kinds of sales organizations, different kinds of merchandising, but you can get from the manufacturers themselves a much clearer picture of that, Mr. Cox. than you can get from me, and you are going to have them on.

Mr. Cox. You think it is proper for you to use your patent rights to prevent that sort of situation?

Mr. SMITH. I do, yes; I think it is sound. I think we maintain and create competition rather than destroy it.

Mr. Cox. You think that is better than letting the manufacturers find out for themselves what kind of situation they may be in?

Mr. SMITH. I do. If we didn't think it was better, we wouldn't follow that policy.

Mr. Cox. And that, of course, is a decision which is made by your company?

Mr. SMITH. Correct.

Mr. Cox. I think I have finished with Mr. Smith. If there is anything I haven't touched upon that you would like to say about any of the answers you have given to me, that is quite all right.

Mr. SMITH. I was in hopes, Mr. Cox, you might say something about compulsory license. Of course, I think if a law is passed, new laws so that you have to give a compulsory license, that it will ruin a great many industries, in that those strongest in the industry, the largest people in the industry, would end up with most of the business and certainly it would ruin the glass business.

Have you thought of this phase of the compulsory license? Supposing you and I, Mr. Cox, are in the button business, producing buttons and we have a patented process for the finish, and we have a mill in a little town in Texas or up in New England or out on the coast, and the only reason we can compete with the larger button concerns who turn out mass production is because we can make a quality button, a much better button than they can, and we have a selected trade, and we made that because we have a patented process. If Congress should see fit to change the laws, why, of course, you and I would have to give the big competitor the right to use that patented process. All his buttons would be quality buttons and you and I would be out of business.

Offhand, it sounds rather nice, compulsory licensing, but just practically it wouldn't work out that way. It would do great injury to so many concerns, and particularly so to the little concern because eventually you have every type of patented process in the hands of the larger concerns. I just submit that idea because it seemed rather far-reaching.

Mr. Cox. Mr. Smith, I find your remarks very interesting, as I am sure the committee does. I want to make clear to you that you may be under a little misunderstanding as to the position of the Department of Justice in that respect. We are not now advocating any such thing as compulsory licensing.

The CHAIRMAN. Some other members of the committee may ask questions of that kind.

Mr. Cox. His remarks brought up one matter that I should like to ask about. Mr. Smith, in granting these licenses, you are faced with a certain amount of bargaining with the licensees, you bargain to and fro as to terms of the license.

Mr. SMITH. Not as to terms. We may disagree with them to some extent about particular details of the license and lease agreement, but the royalty rates are the same to everybody.

Mr. Cox. I understand that, but I am thinking particularly as to these provisions as to types of ware and quantity. You do have a certain play, there is a certain play of bargaining there, isn't there?

Mr. SMITH. I haven't done much of that in the last 5, 6, or 7 years, and I just couldn't answer you; I don't believe there is such an awful amount of it. There may be some. If I were to come to you and you weren't going to give me just everything I wanted, I would probably plead with you a little bit to loosen up, to be a little more generous. I don't know, but people of our organization can tell you more about that.

Mr. Cox. Do you disclose to all of the licensees the terms which are granted to each one, or is that a matter of private arrangement?

Mr. SMITH. Private arrangement.

Mr. Cox. So that if I were a licensee and Mr. Safford were a licensee, unless we told each other, we wouldn't know what terms were in effect, each with the other.

Mr. SMITH. If you came to Hartford we would probably tell you, but we don't say to you, "Here is a complete list of every contract we have drawn."

Mr. Cox. Would you say it is merely a coincidence that your only two unrestricted licenses have been granted to two of the largest companies in the field?

Mr. SMITH. No; I thought I explained that by saying they were doing a national business, they were making broad lines, fields of ware, and they just felt they had to have a broad license, and demanded it.

Mr. Cox. I want to ask you one more question, and then I will really terminate. Wouldn't you say that the effect of your licensing policy as you have described it is to freeze the economic structure of the glass container industry into its present form?

Mr. SMITH. I would say to ease the economic structure, because if we hadn't done certain things, the little independent licensees wouldn't be in business today.

Mr. Cox. That may be true. What I am inquiring into is this: Isn't the effect of your licensing policy to prevent a manufacturer from going into a field of ware which he has not previously been in?

Mr. SMITH. That partially might be true. I don't think it is wholly true. We do occasionally let people in, but I think as a general proposition if a manufacturer is prospering, if he is making a particular line of ware, that unless he had some very good reason, sound reason, we would question somewhat as to how far we should extend that license.

Mr. Cox. Your tendency is to give him a license for the field in which he has been?

Mr. SMITH. Yes; or even if it is going to keep him alive and make him money, we may extend that.

Mr. ARNOLD. You very frankly stated, Mr. Smith, you thought it was undesirable to have everyone able to make all the glass he wanted to because of the various unstabilizing elements which you thought that would introduce into the picture.

Mr. SMITH. That was the general thought.

Mr. ARNOLD. In other words, you think competition in the glass industry is a bad thing?

Mr. SMITH. No; I think it is a very good thing.

Mr. ARNOLD. But free and unrestricted competition?

Mr. SMITH. Do you mean by that that we should give the use of our machines to everybody?

Mr. ARNOLD. No; we are talking about a socially desirable policy for the glass industry.

Mr. SMITH. I would say that any policy that puts into the hands of the consumers glassware at the lowest possible price, if that is true, and I think that is what the industry is doing, was socially desirable.

Mr. ARNOLD. And competition in the glass industry, free and unrestricted competition, is socially undesirable today, you think, or at least you think—and I am not criticizing you in the least—it is desirable to give the Hartford-Empire Co. the right to look over the field and determine the capacity and the quantity and the demand and all of that sort of stuff?

Mr. SMITH. I do, Mr. Arnold, because I don't know who is better able to decide, as I said before, whether there should be 1,000 licenses or 500, or 300, or 50. Now, that has only to do with our own inventions and our own machines. If somebody else comes along with a new idea, something that is revolutionary—

Mr. ARNOLD (interposing). You would buy it up.

Mr. SMITH. We would have to take a back seat or get some new arrangement.

Mr. ARNOLD. But you would like to get control of the new idea and to maintain this humanitarian, paternalistic policy toward the industry?

Mr. SMITH. No.

Mr. ARNOLD. I am not using those words critically, but I thought you do have a humanitarian idea here.

Mr. SMITH. I think we try to encourage the manufacturer to produce better goods all the time, to sell them at a lower price. I think we feel a distinct moral obligation of good business ethics to continue to help him keep in business, but, of course, we get paid for it; we are not a charitable institution.

Mr. ARNOLD. I wasn't criticizing the profits at all. I was simply bringing out what I thought to be your policy; that you thought it was socially desirable to have someone with pretty complete power to determine who would go in and who would stay out of the industry in the interests of stabilization, and that you thought the Hartford-Empire Co. was a pretty good repository of that power.

Mr. SMITH. I think that, so far as we are concerned—and I haven't given enough thought to the various other kinds of industries—

Mr. ARNOLD (interposing). I was talking about glass.

Mr. SMITH. I think, as far as glass is concerned, the industry has been very much benefited by our policy.

Mr. ARNOLD. And insofar as in other industries we could find wise people to keep out this ruinous competition, and to exercise the paternalistic and humanitarian policy, that also would be a good thing?

Mr. SMITH. Yes; if you can find people who live with the industry day by day and have something to offer that industry, and they are part of that industry, but I wouldn't want a board who wasn't in the business, or creating anything, to sit down and have a power like that.

Mr. ARNOLD. And you would rather have that power in private hands than you would in governmental hands?

Mr. SMITH. I certainly would, Mr. Arnold, I am sorry.

Mr. ARNOLD. That is substantially the argument made in favor of the European cartel system, isn't it?

Mr. SMITH. I don't know as I know much about that.

Mr. ARNOLD. Do you know the European cartel system?

Mr. SMITH. No, I am not familiar with it.

The CHAIRMAN. It would appear from the testimony that was submitted this afternoon, Mr. Smith, that your company, by virtue of certain patents granted by the Government of the United States, is in position practically to dominate the manufacture or the production of glass containers.

Mr. SMITH. No. For instance, there is the great suction machine that produces such an enormous quantity of bottles.

The CHAIRMAN. What percentage was that? You said something less than 40 percent.

Mr. SMITH. Twenty-nine point something, I think.

The CHAIRMAN. So you are producing well in excess of 60 percent.

Mr. SMITH. But that is a normal thing to have happen, isn't it, Senator? If we have invented and created the most efficient—

The CHAIRMAN (interposing). Don't misunderstand me, I am not criticizing; I am trying to develop the conclusions which we must all reach after having listened to your testimony. Your company has received from the Government of the United States certain patents which may or may not be granted, according to the position that Congress may take with respect to matters of public policy, so that you are the beneficiary of a grant of power from the Government of the United States, that is from all the people.

Mr. SMITH. Quite true.

The CHAIRMAN. And as the result of that grant, your company now, through its control of patents, dominates this particular industry.

Mr. SMITH. That is right, if you leave out the suction.

The CHAIRMAN. And you do not sell your patents, you do not sell the machines that are made under them, you follow a policy of leasing only. No person may buy a machine outright, and no person or company may use a machine except under the condition that you lay down.

Mr. SMITH. Correct.

The CHAIRMAN. So you follow as a policy the program of strictly examining the power of every licensee to produce.

Mr. SMITH. Correct.

The CHAIRMAN. And you define that power.

Mr. SMITH. Correct.

The CHAIRMAN. You say to licensee A, "You may produce so many bottles of such a kind and character."

Mr. SMITH. Not so many, only in a very few instances. "You may produce bottles of such-and-such character."

The CHAIRMAN. But you never impose—

Mr. SMITH (interposing). Only in a very few instances.

The CHAIRMAN. You do, then, reserve the right to limit the production?

Mr. SMITH. Correct.

The CHAIRMAN. And you exercise that right in some cases?

Mr. SMITH. Correct.

The CHAIRMAN. So that your licensees are under obligation to come to you to find out how many bottles they may produce and what kind of bottles they may produce?

Mr. SMITH. Primarily what kind. Very seldom how many. There are some, but there are many more licenses as to kind rather than the restrictive number.

The CHAIRMAN. In most cases, you want the committee to understand, your desire is to control only the kind of bottle that may be produced by a particular individual, and not the quantity?

Mr. SMITH. Both are true. We have restricted in certain cases the quantity. In most cases we merely restrict the kind.

The CHAIRMAN. And why did you restrict the quantity in those cases?

Mr. SMITH. Because we felt that if that satisfied the licensee's needs and his desires, and if by doing otherwise he was going to overproduce to the disadvantage of somebody else, we would do that.

The CHAIRMAN. And who determines the needs of the licensee and whether or not what he desires to do will be overproduction?

Mr. SMITH. The licensee comes to Hartford and he tells us about his business; what his requirements are.

The CHAIRMAN. And so by virtue of this grant which Congress has given you, through a patent, you undertake to exercise your judgment as to whether he has correctly stated his need or the desire to operate?

Mr. SMITH. That is quite true.

The CHAIRMAN. Now, that boils down, does it not, Mr. Smith, to the exercise by your company of the right to control both the production and the price at which—

Mr. SMITH (interposing). Not the price; we have nothing to do with the price.

The CHAIRMAN. I understand you testified that in none of these contracts do you impose a resale price, but if you can control the production you can thereby control the price, can you not?

Mr. SMITH. No. There has always been, since we have been a corporation, an overcapacity. There is today a large overcapacity in the industry. It is running at 60 percent of full capacity.

The CHAIRMAN. But under this policy which is now permitted apparently by the patent laws, at least, you could, if you desired, or some other corporation if it were in your place and none of your officers had anything to do with it, would be empowered to say to the licensee, "You may not sell these containers which you manufacture for less than such and such a price."

Mr. SMITH. That may be true, but I don't know that it is true. It is a question that we haven't gone into because we don't want to have anything to do with the price or the sale of the article made on our machines. It might be true that we could get five lawyers that would say, "You can do it if you want to," or other lawyers that would say, "You mustn't do it, you are on the border edge," but we do not attempt to do it and we have no interest in doing it.

The CHAIRMAN. But you can control the production.

Mr. SMITH. The production, as to what they make we can control.

The CHAIRMAN. Why is it that you have as a policy refused to follow a policy of unlimited licenses, by which the licensee would be at liberty to produce as many and as many different kinds of containers as he desired?

Mr. SMITH. I tried to explain to you that first of all, in different types of ware, liquor ware, packers' ware, toilet-prescription ware, the various types of ware had to be marketed in a different way, one from another, and I think the manufacturers could explain it to you much more clearly than I could.

The CHAIRMAN. I think you explained it very clearly.

Mr. SMITH. It takes a different kind of organization. If a licensee is making his business and making, say, prescription ware, that is his advertising program, that is his sales force, are tuned up to that particular kind of a business. Supposing he came to us and said, "Well, after all, I would like to make packers' goods," and we had a licensee fifty or a hundred miles away who was in the business of making packers' ware, but which he again sold in a different way, I doubt whether we would give the prescription fellow the right to make the packers' goods.

The CHAIRMAN. And what is the reason that you doubt that you would grant it to him?

Mr. SMITH. I doubt if it would be good business. It might be demoralizing.

The CHAIRMAN. In other words, it might affect the resale price, so that this policy is, after all, a policy designed to maintain the price.

Mr. SMITH. Well, I wish I could answer you "yes" or "no." It has never occurred to me that our policy maintains a price. I would say our policy has prevented ruinous competition.

The CHAIRMAN. That's right.

Mr. SMITH. But as to the price level, or anything of that sort, it maintained a stability in the industry. Labor has been employed continuously, I think, probably better in the glass industry than in any other industry during the depression years.

The CHAIRMAN. And that is because you have the power granted to you by Congress—

Mr. SMITH (interposing). I think we have helped, with no great fluctuation.

The CHAIRMAN. But it is because you have had the power, through a grant from Congress, to control the production in this particular field, and by controlling production, also to control the price.

Mr. SMITH. Also to help stabilize.

The CHAIRMAN. All right, we will put it in that euphonious way, to stabilize the industry. As Mr. Arnold indicated, that is the argument always advanced for the control of industry by private persons, is it not?

Mr. SMITH. I don't know as I quite understand that question, sir.

The CHAIRMAN. That, of course, is perhaps going a little bit afield.

Let me ask you now, How do you fix the royalty which you charge, and the license fee?

Mr. SMITH. The royalties were fixed when we first started business, and the only change in those royalties has been reductions, and they are based on a sliding scale. If you make a 10-ounce bottle, it is one royalty; if it weighs 7 ounces, it is another royalty; if it weighs 15 ounces, it is another royalty. We determined that by figuring out what the saving would be, either the saving in labor or the total saving, and we struck some very interesting figures, and finally estab-

lished on what we call about one-third of the price of the saving in labor or the total saving, and we have never changed those figures. I think somewhere here we have the exact situation, but roughly speaking, two-thirds of the saving went to the manufacturer and we collected one-third.

Now, that was a very tangible third, but the manufacturer made a great deal more money than that, because if he had a large tank filled with molten glass, a hundred tons of this molten glass in a tank, he had to make money. The only way he could make money was to put into salable ware so many tons of glass a day, and the fact that our machinery let him put so many more tons per day than he had ever been able to put before, he had a great saving in overhead.

It is a rather romantic situation. I don't want to keep you, but our company came into being through an idea. Here was a glass manufacturer who was making jars for the Beech-Nut Packing Co. You remember in the old days you bought your bacon and mustard and peanut butter (and still do, to some extent) in glass jars, and the Beech-Nut Packing Co. developed a sealing which automatically made a vacuum seal on the jars. They found they couldn't get accurate enough jars to do that without great losses. They were using millions and millions of jars each year and they went and complained to the manufacturer producing these by hand, and said, "Your jars are costing us too much money. Breakage is too great; we are losing a lot of them in this sealing process. For heaven's sake, let's get together and hire some engineers in Hartford to see if we can't make glass automatically."

That is the start. Mr. Peiler, in 1911, started to investigate the glass industry and he found there was only one automatic means of producing glassware, and that belonged to the great Owens Co., a suction machine. We made a complete study of the patent situation and finally Mr. Peiler, the inventor, evolved this method of feeding glass.

At that time all the hand people were having pretty tough sledding.

The CHAIRMAN. I think, Mr. Smith, it is the intention of the Department of Justice to go into the history.

Mr. COX. We are going to put that in.

The CHAIRMAN. If you want to make a suggestion, Mr. Goodrich—

Mr. GOODRICH. Yes, please.

The CHAIRMAN. Mr. Smith, two contracts were put into the record this afternoon, one of them the Whitall-Tatum contract¹—

Mr. SMITH (interposing). As regards a *lehr*.

The CHAIRMAN. Each of which contains a provision reserving to your company the right to withdraw the license from any licensee who uses the particular machine thereby licensed in connection with any other machine which is not licensed by you.²

Mr. SMITH. That was our policy. Now, let me explain, if I may. That still is our policy as regards our forming machine, because we have a hook-up between the feeder and former which is under patent,

¹ Referring to "Exhibits Nos. 121 and 122."

² *Ibid.*

so we are considering that one unit, and it is a little different situation from the lehr situation.

The CHAIRMAN. But you have abandoned that policy with respect to lehrs?

Mr. SMITH. The stacker and the lehr.

The CHAIRMAN. Do you wish the committee to understand that, except for these two cases you have come to the conclusion that that policy of restricting the use to machines which you yourself control is not followed any longer except in these two instances?

Mr. SMITH. You are referring to lehrs?

The CHAIRMAN. Yes.

I understood the testimony of Mr. Safford to be that that had been eliminated from the general contract.

Mr. SMITH. Yes; not as far as a feeder hooked up to our forming machine is concerned.

The CHAIRMAN. But you still feel that you have the right to reserve that right if you care to do so?

Mr. SMITH. Yes; because that is a different situation and under a different set of patents, and we have patents on the combination. I mustn't get into the technical end of this thing. I really know nothing about it.

The CHAIRMAN. Of course, that suggests to my mind, as a Member of Congress, whether or not it is a wise thing for Congress to allow any law to stand which enables the holder of any patent to say to the user of that patent that he may not use it in connection with any other patent unless the licensor permits him to do so.

You see the question that it raises.

Mr. SMITH. I think that would wholly depend upon so many varying situations. What is the patent situation at that time? What does the patent cover? It may cover two machines. As a matter of fact we have let people use our lehrs with other machines, and the situation varies to such a degree and has so many legal angles that if you would like to go into that I wish you would ask our attorneys tomorrow.

The CHAIRMAN. Secretary Patterson, I am rather apologetic. I think I have taken up a good deal more time than I wanted to. Do you have some questions to ask the witness?

Mr. PATTERSON. Most of my questions of Mr. Smith have been answered, but there are one or two with reference to the international aspect.

The CHAIRMAN. Mr. Patterson, would you care to come over here?

Mr. PATTERSON. Mr. Smith, I am going to cut these questions rather short, because you have been on the stand 2 hours and it is rather burdensome.

Is any part of the process you use subject to license from foreign patent holders?

Mr. SMITH. No.

Mr. PATTERSON. None whatsoever?

Mr. SMITH. Not if I understand you correctly.

Mr. PARHAM (of counsel for the witness). That is substantially correct. One particular patent I have might possibly bear.

Mr. PATTERSON. Is any of your machinery leased to foreign glass manufacturers, Mr. Smith?

Mr. SMITH. None leased. We have sold our patent rights in 17 different countries, but we have sold those rights outright. We have no ownership, nor do we collect royalties or anything of that sort from across the water.

Mr. PATTERSON. In 17 foreign countries, and you have no further connection with them—sold outright; you have your money, are not represented on the boards, and it is a clean slate?

Mr. SMITH. That's right.

Mr. PATTERSON. Go right along and develop that, Mr. Smith, if you have any thoughts on it.

Mr. SMITH. They thought there might have been one point where I was 99½ percent right and one-half percent wrong, and they were trying to clear it.

Mr. PATTERSON. You are ahead of most of us if you are 99 percent right. I might tell you, Mr. Smith, I am personally getting this more or less for the Patent Office. My colleague, the Commissioner of Patents, is here with me and we are after developing certain information which will help us, not only in the committee work but with the Patent Office end of it, when it comes to legislation.

Have you any idea as to what percentage of the total glass-container production of these 60 foreign countries is made on your machines?

Mr. SMITH. No; I really haven't. I think in England, well, I haven't the statistics. Our equipment is used there quite extensively; it is used quite extensively in France. I haven't heard much about Germany lately, Czechoslovakia, Argentine, Brazil, even in China, and is used extensively in Japan. There may be others. I am not ticking very well just now.

Mr. PATTERSON. That is a satisfactory answer, Mr. Smith. Thank you.

Now, is there any clause in your leasing contracts restricting their use? You sold these outright. In your bill of sale or in your contract to these foreign manufacturers, are they restricted from selling in the United States or in any other market?

Mr. SMITH. No. You see what we did, we took out patents in all these foreign countries, and when the patents issued, like the British patents, French patents and so on, the manufacturers over there came over here and said, "Here, we would like to buy your patents," and we sold them, and in some cases where we hadn't patents issued up to that time they agreed not to ship the machines into that country which had no patents, to protect our particular type of machine.

Mr. PATTERSON. Thank you. Have you any idea, Mr. Smith, as to the percentage of world production produced in this country, in the United States?

Mr. SMITH. No; I haven't the least idea.

Mr. PATTERSON. You do have some idea, though, I imagine, as to how the costs of production compare here versus the leading countries abroad.

Mr. SMITH. No; I'm sorry. I think you can get that information from a manufacturer of glass. Personally, I have none.

Mr. PATTERSON. We can get that a little later on.

Now, this is my last question. I am advised that the exports of glass containers during 1937 were valued at \$3,320,000 and that im-

ports during the same year were valued at \$719,000, which is a comparatively small quantity in relation to domestic production of \$161,000,000. This indicates that the United States container manufacturers must be among the world's lowest cost producers. Now, Mr. Smith, would you say that this is principally due to the development of automatic machines in this country?

Mr. SMITH. I think so; yes.

Mr. PATTERSON. Anything else?

Mr. SMITH. Well, further than that, of course, you have great research and development undertakings here. We spend a great deal of money, several hundred thousand dollars, five or six hundred thousand dollars, perhaps, on research and development. Other big research concerns are doing the same. I suppose Corning Glass Works has the finest research laboratory in the world, and when you tie up all those things, and the aggressiveness and inventive ability of the United States, it is a leader in glassware. It is just bound and got to be satisfactory.

Senator KING. You have more efficient labor, too, do you not, and greater use of electrical appliances to be used in connection with the machinery.

Mr. SMITH. That I wouldn't know, Senator. Of course in some of the countries where you have such free water power across the way, that may have a similar effect. I am not prepared; I don't know enough about the subject.

The CHAIRMAN. Do any other members of the committee have any questions to ask before we recess?

Mr. DAVIS. Mr. Smith, can you tell us whether any machine manufactured in these foreign countries under your patents is shipped into the United States?

Mr. SMITH. No; none. None are shipped in at all under our patents. It isn't permissible. We wouldn't allow it.

Mr. DAVIS. You mean you have a clause against that in the sale of the patent? Did you have a contractual provision against shipment of machines into this country?

Mr. SMITH. In some cases in the early days we did.

Dr. LUBIN. Mr. Smith, may I ask whether your corporation owns any patents which are not now being used in connection with either the manufacture or development of your own product?

Mr. SMITH. I wouldn't know. I suppose there are some.

Mr. PARHAM. I have got some, but I don't think the principal ones are included.

Dr. LUBIN. Do you own any patents applicable not to your own machinery, but to machinery manufactured by other people?

Mr. PARHAM. Yes; I have some.

Dr. LUBIN. In other words, those patents are being held by you so that in the event anybody else should use that procedure or method on machines other than yours, and they are not applicable to yours so that they can't be used on yours, you are in position to bring infringement suits against them?

Mr. PARHAM. I happened to think of one case in which we have licensed the other machine.

Dr. LUBIN. Can you tell me how many cases of infringement you have brought in the last 5 years?

MR. PARHAM. I haven't been sworn as yet. That is in a book which Mr. COX is going to introduce.

DR. LUBIN. May I ask a question of Mr. Smith? You may not be in a position to answer it, but I would be interested if you could. If I were a person with the necessary capital and reputation and I wanted to go into the production of milk bottles, and assuming for the sake of argument that at the time I came to you and asked for a license the milk-bottle production was more or less on a par with the market situation—in other words, you didn't have that large over-capacity that you now have, would you give me a license in preference to somebody who already owned a license who wanted to expand his production?

MR. SMITH. That is a pretty tough question. We certainly would receive with great seriousness your application. Whether we would give it to you or not would depend on probably 10 or 15 other different reasons. I just can't tell you. I can get up a set of reasons some time. I can't tell you now.

I don't think you meant to imply it, but certainly we would see that the production capacity was maintained so that, so far as our machinery was concerned, milk bottles were being produced at the lowest possible cost.

DR. LUBIN. But you couldn't say at this time that in the event production was being increased—

MR. SMITH (interposing). I said your application would receive serious consideration.

DR. LUBIN. Let me ask one final question. I note in your testimony you mentioned the fact that one of the companies that has freedom to produce in unlimited quantities and with few exceptions freedom to produce unlimited types of glass is the Owens-Illinois Glass Co. Is there a financial relationship between the Hartford Empire and the Owens-Illinois through the Owens-Corning and the Empire Machine?

MR. COX. We are going into all of that question.

MR. SMITH. There is that chart.¹

SENATOR KING. I would like to ask one question: By your policies which you have pursued, have the prices of your products been decreased, cheapened?

MR. SMITH. The prices of glassware to the consumer have been continuously decreased.

SENATOR KING. Is that a result of your policies or the result of your licensees', or both?

MR. SMITH. I should say when you manufacture by the use of our machines you manufacture at the lowest possible cost, and that has been continually happening, according to our figures. Glassware today, certainly in a number of fields, is being offered to the consumer at a far less price than it was a few years ago, but there again the manufacturers themselves can speak for that. I am in no position to speak for them.

SENATOR KING. Do you think the policies which you have pursued, you and the manufacturers, either individually or jointly, have resulted in the cheapening of the prices?

¹"Exhibit No. 113," appendix, p. 762.

Mr. SMITH. I don't think there is any question about it.

Senator KING. Do you think your policy has in any way—and if so, to what extent—made for monopolistic control of prices, either of production or of distribution?

Mr. SMITH. No; I don't think there is any monopolistic control. I think we have so many licensees that are competing, one against the other, in various fields of ware that there is no control.

Mr. ARNOLD. Well, you said awhile ago that there was a monopolistic control but it was in wise hands.

Mr. SMITH. So far as the use of our own inventions is concerned, yes; but that use has been spread to such a degree, there are so many manufacturers using our equipment, that there is a free competition between those manufacturers.

Mr. COX. I would like to put in the record this memorandum on "Policy of the Hartford Empire Co." that was discussed and that I read from this morning. It has been identified.

Mr. SAFFORD. Mr. COX, could it be put in as a personal memorandum of Mr. Herbert Knox Smith?

Mr. COX. I will offer it on these terms, that it is a memorandum entitled "Memorandum on policy of Hartford Empire Co., February 18, 1930," which we took from your files and which we understand was written by Mr. Herbert Knox Smith. That is as far as I can go.

The CHAIRMAN. Which the witnesses have said was apparently written by Mr. Herbert Knox Smith.

(The memorandum referred to was marked "Exhibit No. 125" and is included in the appendix on p. 771.)

Representative SUMNERS. Mr. Smith, are you going to be available tomorrow? Do you want to leave this evening?

Mr. SMITH. I had hoped to be excused, but Mr. COX tells me that he may want me back again, and I don't think I have much else to offer.

Mr. COX. Much as I regret it, I am going to have to keep Mr. Smith here for part of this week, at least, I think.

Representative SUMNERS. Mr. Smith, these other people have just been skimming around what you know, and tomorrow I want to ask you two or three questions that will really explore your wisdom.

The CHAIRMAN. Thank you, very much, Mr. Smith.

The committee stands in recess until tomorrow morning at 10:30.

(Whereupon, at 4:30 p. m., a recess was taken until Tuesday, December 13, 1938, at 10:30 a. m.)

INVESTIGATION OF CONCENTRATION OF ECONOMIC POWER

TUESDAY, DECEMBER 13, 1938

UNITED STATES SENATE,
TEMPORARY NATIONAL ECONOMIC COMMITTEE,
Washington, D. C.

The committee met at 10:45 a. m., pursuant to adjournment on Monday, December 12, 1938, in the old caucus room, Senate Office Building, Senator Joseph C. O'Mahoney presiding.

Present: Senators O'Mahoney (chairman), King, and Borah; Representative Sumners; Messrs. Arnold, Patterson, Lubin, Henderson, Davis, and Peoples.

Present also: Department of Justice staff for Temporary National Economic Committee study—counsel, H. B. Cox (Special Assistant to the Attorney General); Joseph Borkin, Ernest Meyers, Charles L. Terrel, Benedict Cottone, David Clarke, George Dession, Fowler Hamilton, H. C. Engelbrecht, Victor H. Kramer, J. M. Henderson, Monroe Karasik, Irving Glickfeld, Hyman Ritchin, Norman Bursler, and Seymour Lewis; also chief counsel for Federal Trade Commission Temporary National Economic Committee study, George W. Williams.

The CHAIRMAN. The committee will please come to order.

Mr. Cox, are you ready to proceed?

Mr. Cox. Yes. Our first witness this morning is Mr. Parham.

The CHAIRMAN. Before you begin, however, I should like to take this opportunity of making an announcement to the members of the committee. Secretary Patterson, member of the committee, representing the Department of Commerce, today suggested to me that the Department of Commerce would like to have the committee assign later 2 or 3 days for the presentation by the Department of Commerce of testimony with respect to the general features of the patent law. That would be a presentation altogether independent from that which is now being made by the Department of Justice and would be intended primarily for the purpose of showing the sort of change in the patent law which the Bureau of Patents might be willing to recommend to Congress, and if there is no objection upon the part of the committee the request of the Department of Commerce will be granted, and a date for those hearings will be fixed later.

Representative SUMNERS. Mr. Chairman, will that come after we shall have concluded taking testimony with reference to patents?

The CHAIRMAN. That will come after we have concluded the presentation of the case by the Department of Justice.

Mr. ARNOLD. May I make this explanation, Mr. Congressman: We have been in close cooperation and consultation with the Department of Commerce, and for the purpose of orderly presentation there are two things which we have separated; one, the questions of the proper

technical and procedural operation of the patent law, with which the Department of Justice is not charged, with which they are not particularly skilled; and our own hearing is with the restraints-of-trade aspect, and we are cooperating with the Department of Commerce in the other; but we thought, in the interest of orderly presentation, it would be better to separate those two things.

Representative SUMNERS. The only point I had in mind is whether it is a matter of bringing the existing law to the attention of the committee or whether it was a suggestion of remedial law. It seems to me that if it is going to make a suggestion toward remedial legislation, that ought to be toward the conclusion of the presentation with reference to patents.

Mr. ARNOLD. The date will have to be fixed.

The CHAIRMAN. That is what we had in mind.

Senator KING. I assume, in the announcement made, it is not intended to preclude persons who desire to present their views for or against the present patent situation.

The CHAIRMAN. Not at all.

Mr. COX. I think Mr. Parham has not yet been sworn.

The CHAIRMAN. Do you solemnly swear the testimony you are about to give in this proceeding shall be the truth, the whole truth, and nothing but the truth, so help you God?

Mr. PARHAM. I do.

Representative SUMNERS. Before you do that, at the conclusion of the session last evening I understood Mr. Smith was to be here.

Mr. COX. Well, I am sorry if I gave the impression that he was going to be here today. I did plan to have him back tomorrow possibly or the next day.

TESTIMONY OF SIDNEY F. PARHAM, PATENT ATTORNEY, HARTFORD-EMPIRE CO., HARTFORD, CONN.

Mr. COX. Will you give the reporter your name and address?

Mr. PARHAM. My name is Sidney F. Parham. I am a resident patent attorney of the Hartford-Empire Co., being chief assistant to Mr. R. D. Brown, the vice president of that company in charge of patents.

Mr. COX. How long have you held that position?

Mr. PARHAM. I have been resident patent attorney since 1926.

Mr. COX. Did you do any work for the company before that?

Mr. PARHAM. Yes, sir. Prior to that time I was engaged in patent law practice in Washington with Dorsey & Cole and spent a considerable portion of my time on work for the Hartford-Empire Co.

Mr. COX. Mr. Parham, yesterday Mr. Smith testified that the Hartford-Empire Co. held certain patents relating to methods or machines used in automatic feeding of glass by the gob method. Do you recall that?

Mr. PARHAM. Yes, sir.

Mr. COX. I ask you whether it would be possible to classify the patents in the sense that some of them are basic in character and others are on improvements or details.

Mr. PARHAM. It might be possible to classify them, but I am not prepared to give you an accurate classification at this time.

Mr. COX. Well, I will ask you about two specific patents. I refer to the one which is numbered "1,573,742." I think that is the so-called phase change patent.

Senator KING. What is that name?

Mr. COX. Phase change; p-h-a-s-e. I ask you about that patent. Will you describe that as a basic patent?

PATENTS IN THE GLASS CONTAINER INDUSTRY

Mr. PARHAM. I would describe that patent as an exceedingly important patent but possibly not the basic patent in the gob-feeding art.

Mr. COX. Would you say the basic one was 1,655,391?

Mr. PARHAM. No, sir; I would not. I would say that is also an exceedingly important patent with broad control; yes.

Mr. COX. Of course, those have figured very largely in the litigation which your company has had.

Mr. PARHAM. That is true.

Mr. COX. On the so-called phase change, you sued the Nivison-Weiskopf Co. at one time?

Mr. PARHAM. Yes, sir.

Mr. COX. And the Kearns-Gorsuch?

Mr. PARHAM. Yes, sir.

Mr. COX. The Lamb Co.?

Mr. PARHAM. Yes, sir.

Mr. COX. And the Obear-Nester Co.?

Mr. PARHAM. Yes, sir.

Mr. COX. And on the second patent, the 1,655,391, which I shall hereafter refer to as the Peiler patent merely for convenience—

Mr. PARHAM (interposing). They are all Peiler patents, Mr. Cox.

Mr. COX. Well, there is some dispute about that, although I understand it is their name.

Mr. PARHAM. Not in my mind, sir.

Mr. COX. Well, I am not going to discuss that with you now. I am just going to refer to it by that term so we won't confuse the numbers. That patent has also been important in your litigation.

Mr. PARHAM. You are also referring to 1,655,391?

Mr. COX. That is the patent you sued Hazel-Atlas Co.?

Mr. PARHAM. Correct.

Mr. COX. Knappe-Coleman?

Mr. PARHAM. Yes, sir. I beg your pardon. We did not sue Knappe-Coleman on that.

Mr. COX. Was it on the other patent?

Mr. PARHAM. On the other one; the phase change.

Mr. COX. And you sued the Reed Glass Co. on this?

Mr. PARHAM. That is correct.

Mr. COX. And you sued the Florida Glass Co.?

Mr. PARHAM. That is correct.

Mr. COX. And the Jeanette Glass Co.?

Mr. PARHAM. I believe so.

Mr. COX. When was the 1,655,391 patent issued?

Mr. PARHAM. January 1928.

Senator BORAH. Have you another name by which you can call that?

Mr. COX. I am going to try to refer to the 1,655,391 as the Peiler.

Mr. PARHAM. I'd call it the shaping patent.

Mr. Cox. You might use the term which Mr. Parham did, calling it the shaping patent for 391 and the phase change for the other.

Mr. PARHAM. We ourselves call it the stuffing patent.

Mr. Cox. Which one is this?

Mr. PARHAM. The same patent, 1,655,391.

Mr. Cox. Have you any choice between "shaping" and "stuffing"?

Mr. PARHAM. I prefer "stuffing," because the feature of the patent is the stuffing of the upper end of the charge to give it an artificial shape which is different from the natural shape it would have.

Mr. Cox. That patent expires 17 years after the date of issue, or about the 2d of January 1945.

Mr. PARHAM. That is the law; yes, sir.

Mr. Cox. And when was the phase-change patent issued?

Mr. PARHAM. I will have to check. I think it was 1926.

Mr. Cox. My recollection is that it was about that time and it expires some time in February 1943.

Mr. PARHAM. That would be correct.

Mr. Cox. Now I want to call your attention to three other patents, Mr. Parham. They all start out with 2,073 and run from 2,073,571 to 2,073,573. Do you recall those patents? Do you have a copy of those?

Mr. PARHAM. I think I have copies of some of our patents with numbers in those series; yes, sir. There is a Peiler patent, 2,073,572, I recognize as one of our patents; Steimer patent, 2,073,571, I recognize as one of our patents; and patent to Steimer, 2,073,573, is also one of our patents.

Mr. Cox. What do you call these patents? I just want the term now.

Mr. PARHAM. We call the Peiler patent the heated-hood case, simply a nickname in the office. The patent, as a matter of fact, is directed very broadly to the idea of feeding suspended charges by the use of viscous glass, the charges being hung up at the orifice of the feeder until a full charge is accumulated, at which time a pair of mechanical shears enter and sever the charge to permit a unit of glass to drop as a unit into the mold of the molding machine.

Mr. Cox. What do you call the Steimer patents? Do you have one name for them or two names?

Mr. PARHAM. I call them the Steimer patents. The one with the higher number is a very minor patent.

Mr. Cox. If I hereafter refer to the heated-hood patent and the Steimer patents, you will understand what I am referring to?

Mr. PARHAM. Yes. The reason it is called the heated-hood patent is it happens the particular embodiment of that broad invention which is shown in the patent drawing shows a hood which comes down below the orifice or the opening in the feeder, and there is heat applied in that hood for the purpose of curing any scar which the severing operation might have left on the stream of glass.

Mr. Cox. When were the Steimer patents applied for?

Mr. PARHAM. The Steimer patents were applied for in February 1910.

Mr. Cox. They were applied for by Mr. Steimer?

Mr. PARHAM. Yes, sir.

Mr. Cox. Can you tell us when they were acquired by Hartford-Empire?

Mr. PARHAM. They were acquired by Hartford-Empire—they were not acquired directly by Hartford-Empire.

Mr. COX. They were acquired in the first instance by the Empire Machine Co.

Mr. PARHAM. They were acquired by Empire Machine Co. and Hartford-Empire in 1917.

Mr. COX. The consideration for that acquisition was \$2,300, is that right?

Mr. PARHAM. That sounds right.

Mr. COX. It is right, isn't it?

Mr. PARHAM. I believe so, as nearly as I can remember. I can check back and be sure.

Mr. COX. I want to review briefly with you the history of those two Steimer patents. They were in the Patent Office under consideration by an examiner from 1910 to 1916, is that correct?

Mr. PARHAM. Yes, sir; there was ex parte prosecution, as we call it, from 1910 to 1916, during which time Mr. Steimer's own attorney prosecuted the case.

Mr. COX. By the way, is Mr. Steimer still alive?

Mr. PARHAM. No, sir.

Mr. COX. When did he die?

Mr. PARHAM. I think it was along around 1919, or something of that sort, but I am not certain.

Mr. COX. Then from 1916 to 1925 these patents were involved in interference in the Patent Office, is that correct?

Mr. PARHAM. That is correct, sir. I think there were interferences that continued after 1925.

Mr. COX. I think there were, as a matter of fact, but there was a development at that point where at least under one of the patents there was a division and a patent issued under that division, is that correct?

Mr. PARHAM. Yes, sir; there was a division, and the division was then put into interference and after that interference was over, the patent issued on the division; I take it you are referring to the division of patent which we put in suit.

Mr. COX. That is right. That is one of the patents that was involved in the Nivison-Weiskopf suits.

Mr. PARHAM. And in the Obear-Nester and Kearns-Gosuch suits also.

Mr. COX. Going back to the part of the application still left in the Patent Office, that other part of the patent was prosecuted before the examiner and the Board of Appeals in the Patent Office from 1925 to 1929, is that correct?

Mr. PARHAM. I made a memorandum of those dates. After they came out of the interference in 1925 they were prosecuted before the primary examiner until April 14, 1927. Thereupon an appeal was taken.

Mr. COX. That was to the Board of Appeals.

Mr. PARHAM. That appeal was taken to the Board. Because of the general crowded condition of dockets, the Board did not render its opinion until August 17, 1929. After an opinion adverse to the application had been rendered we immediately filed a bill of complaint under 4515 Revised Statutes.

Mr. COX. Perhaps the committee might like to know that is a provision—but you go ahead and describe it.

Mr. PARHAM. It is a procedure in the nature of a suit in equity which you bring to enforce the issuance of a patent which you believe is wrongfully refused by the Patent Office.

It is used frequently in important cases where it is necessary to get the testimony of witnesses, it being impossible to make a record by testimony in the regular course of appeals in the Patent Office, and we wished the testimony in this case so we proceeded in that way.

Mr. Cox. In other words, this was a situation where the Patent Office declined to give you a patent on your application and you took advantage of the procedure provided in this section to seek relief in the courts.

Mr. PARHAM. That is true to the extent that they had refused to give us certain claims which we thought we were entitled to. They had allowed other claims which we did not think adequately covered the invention.

Mr. Cox. Do you recall why they refused to give you the claims?

Mr. PARHAM. It was a question of the prior art. It was a Hitchcock patent, I believe.

Mr. Cox. Then you went to the Supreme Court of the District of Columbia, is that correct?

Mr. PARHAM. Yes, sir; we went there. We found that court docket quite crowded. We finally got to trial in November 1932.

Mr. Cox. When was the suit filed?

Mr. PARHAM. The suit was filed on September 3, 1929. As I said, the trial took place in November 1932. After the trial the court held the case under advisement for over 2½ years and rendered a memorandum opinion on May 3, 1935, in general terms sustaining the position of the Patent Office. Appeal was taken to the Court of Appeals, District of Columbia, May 28, 1935. The case was argued April 9, 1936, and a decision favorable to Steimer was rendered December 7, 1936, and the patent was issued as promptly thereafter as possible.

Mr. Cox. The court in effect directed the Patent Office to issue the patent?

Mr. PARHAM. Yes, sir.

Mr. Cox. That history you have given covers the Steimer patents; except for the date of application, are the facts of that history substantially correct as applied to the Peiler patent?

Mr. PARHAM. No.

Mr. Cox. Will you tell us briefly what the difference was there?

Mr. PARHAM. It was in the latter course of the history, but the Peiler patent, known as the heated-hood patent, the one I believe to be the basic patent in the gob-feeding art, was filed in March 1914. In 1915 the Patent Office suggested claims for interference. We were placed in interference with several applications and we were placed in several interferences. I believe the total number of those interferences was something like—

Mr. Cox (interposing). Mr. Parham, you can go into as much detail as you would like, but what I am interested in is the chronology.

Mr. PARHAM. I would like to go into detail, because I want to paint the proper picture.

Anyway, it was in a large number of interferences which together extended for a period of 12 years. Thereafter we proceeded as in the *Steimer case*. That case was consolidated for trial with the

Steimer case, thus getting an earlier date than it would otherwise have gotten. We took an appeal at the same time and got a favorable decision from the court of appeals and were issued a patent as promptly as possible.

Mr. COX. Can you tell us exactly the date when that heated-hood patent issued? You haven't told us that yet, have you?

Mr. PARHAM. No; I didn't.

Mr. COX. I think it was issued March 9, 1937.

Mr. PARHAM. March 9, 1937, is correct. That's right.

Mr. COX. Of course that patent will exist for 17 years. Is that correct?

Mr. PARHAM. From that date.

Mr. COX. And expire in 1954?

Mr. PARHAM. Yes, sir; that is correct.

Mr. COX. A moment ago you described that heated-hood patent as a basic patent in the gob-feeding art.

Mr. PARHAM. I believe it to be so.

Mr. COX. Do you mean by that that the patent covers all of the known forms of feeding, automatically feeding, glass in gobs to forming machines?

Mr. PARHAM. I should say it covers all suspended-charge feeders; if that is what you understand by "gob," it covers all gob feeders.

Mr. COX. When you say it covers all suspended charge feeders, you mean every kind of feeder in which the gob, after it comes through the orifice, hangs without any support?

Mr. PARHAM. Let me correct myself a moment. The broad claim, which I believe practically covers all suspended-charge feeding or gob feeding, if you wish to use "gob" to mean suspended charge, covers all of those types of feeders which I know of in which viscous glass is employed and in which the charges are cut off by mechanical shears. I do not happen to know of any commercial feeders which do not use viscous glass and the severance by mechanical shears.

Mr. COX. Would it be accurate to say, then, that that patent covers all automatic glass feeders excluding the Owens suction machine?

Mr. PARHAM. No, sir.

Mr. COX. What doesn't it cover?

Mr. PARHAM. The feeders known as stream feeders, of which there have been quite a variety in the past, are not covered by that patent. There are some of those being used commercially now at the Kerr Glass Co., particularly. They use a stream feeder to make pressed and blown ware. I happen to know of another company, which is not in the container art, which also uses a stream feeder. I think the Hazel-Atlas Co. and Ball Bros. use stream feeders for certain articles.

Mr. COX. Perhaps I might interpose this question: Is there any other feeder besides the Owens suction and the stream feeder that you think is not covered by this patent?

Mr. PARHAM. Yes, sir. There is what is known as a ribbon feeder.

Mr. COX. That is not used for containers to any great extent, is it?

Mr. PARHAM. To make tumblers.

Mr. COX. That is pressed and blown ware, usually, isn't it?

Mr. PARHAM. No, sir; tumblers are paste mold ware.

Mr. COX. I am speaking of the commercial classification in the industry.

Mr. PARHAM. I think still they are paste mold.

Mr. COX. Is it ever used to make milk bottles?

Mr. PARHAM. No.

Mr. COX. Fruit jars?

Mr. PARHAM. No.

Mr. COX. Used to make packers' ware? I am asking about packers' ware, which is used to pack food, and I ask you now whether you can tell me any place in this country where that feeder you have named is being used for that purpose.

Mr. PARHAM. The feeder which I named is being used by the Corning Glass Works at its Providence plant to make articles which you may call either a tumbler or a container, a packers' container, according to the way it is used. The ones that are being made there to my knowledge are sold as tumblers. They are used as tumblers, but identically formed and shaped articles, made by the Westlake process, are used as packers' ware.

Mr. COX. Are those made and sold as packers' ware?

Mr. PARHAM. I understand they are.

Mr. COX. What company does that?

Mr. PARHAM. Libbey Glass Co.

Mr. COX. They make them and use them themselves?

Mr. PARHAM. They make them and sell them; they do not fill them themselves.

Mr. COX. Is there any place else you can think of where that machine is used for making containers of any kind?

Mr. PARHAM. I can think of no other place.

Mr. COX. Is it ever used to make narrow-neck ware of any kind?

Mr. PARHAM. Not that I know of.

Mr. COX. Opal ware?

Mr. PARHAM. Not that I know of.

Mr. COX. You are quite sure about the ribbon machine being used by Libbey?

Mr. PARHAM. I didn't say the ribbon machine is being used by Libbey. The Westlake machine is being used by Libbey to make an article which is in the shape of a tumbler and which may be used by packers. The Corning Glass Works uses the ribbon machine.

Mr. COX. Is the Westlake machine not covered by this patent we are talking about?

Mr. PARHAM. No; it is not.

Mr. COX. You have named four feeders, the Owens suction feeder—

Mr. PARHAM (interposing). I don't call that a feeder.

Mr. COX. That's all right. Mr. Smith and I were talking that way yesterday. And the Westlake feeder, the ribbon machine, and the stream-flow feeder you say are not covered by this patent. Is that correct? Can you think of any others?

Mr. PARHAM. I can't think of any others at the moment.

Mr. COX. So, except for those four, this patent covers all known forms of gob feeders; is that right?

Mr. PARHAM. I think that is true, and none of the four that I mentioned are gob feeders.

Mr. COX. And none of them are used extensively except possibly the stream feeder for production of glass containers; is that correct?

Mr. PARHAM. Well—

Mr. COX (interposing). I am not asking what can be done; I am asking what is done today.

Mr. PARHAM. I realize that, but the question is, Do you mean extensively by a large number of concerns, or by that do you mean to make a lot of ware, because the ribbon machine makes lots of ware?

Mr. COX. I mean, what part of the glass containers now manufactured in this country, and by containers I am not speaking of tumblers or tableware or anything of that sort, is made by that sort of machine?

Mr. PARHAM. I am not a statistician and I don't know the exact figures. I think Mr. Smith told you yesterday that something in the neighborhood of 30 percent or more were made by means other than the gob feeders.

Mr. COX. You know, don't you, that most of that 30 percent is made by the Owens suction machine?

Mr. PARHAM. I know a good portion of it is.

Mr. COX. Most of it is—29 percent.

Mr. PARHAM. I don't know the figures; I am not a statistician.

Mr. COX. You heard Mr. Smith testify yesterday that it was 29 percent?¹

Mr. PARHAM. I will accept his word for it.

Mr. COX. You don't have to be a statistician for that, do you?

Mr. PARHAM. No.

Mr. COX. You are quite clear, are you, that this new patent, the Peiler patent, doesn't cover the stream feeder?

Mr. PARHAM. You mean by Peiler patent the heated hood; it does not cover the stream feeder. Now, which stream feeder are you speaking of?

Mr. COX. I am speaking about the same stream feeder you were talking about.

Mr. PARHAM. When you speak about the old Brooke feeder it does not. There may be modifications that come under some claim, but I don't believe there are. I don't think the other feeders are covered.

Mr. COX. Is that what you are going to say when you sue those people some time, Mr. Parham?

Mr. PARHAM. Why do you assume that I am going to sue those people?

Mr. COX. You sue everyone sooner or later, don't you?

Mr. PARHAM. I don't think so. We sue only where there is infringement.

Mr. COX. I assume that that is so.

Representative SUMNERS. Mr. Chairman, I hardly believe that is very illuminating.

Senator KING. I share your views.

Mr. COX. I think the witness is being reluctant. I think, as a matter of fact, if we are called upon to demonstrate the litigation policy of this company, we can show that they have sued or threatened to sue almost everybody.

Representative SUMNERS. How is that to guide us in our determination of policy on this thing?

¹ See *supra*, p. 383.

Senator BORAH. I think it has a great deal to do with it.

Mr. COX. I am not going to pursue it any further, but I would like to point out this to you, sir, that one of the most effective ways of using a patent to achieve a position of dominance in an industry, quite apart from the rights which the patent gives you as a patent, is by litigation, because if you have the resources to engage in litigation you can eventually wear out your competitors or so weaken them that their competitive position in the industry is one where they are of little or no account. We expect to produce some testimony of that kind.

The CHAIRMAN. May I suggest, Mr. Cox, that you ask the witness to state in his own language why he termed this particular patent of which you are speaking a basic patent?

Mr. GOODRICH (of counsel for the witness). May I request that in view of Mr. Cox's statement this witness be permitted to go into the various suits this company has brought, to show why those suits were brought, because it is our position that we sued where our patents were being infringed, and no place else?

Mr. ARNOLD. Mr. Chairman, it seems to me that to get an orderly presentation of this matter we must present our case. It seems to me that Mr. Cox is quite right; the witness has seemed somewhat reluctant. We are sorry if we seem to delay matters, but such presentations as Mr. Goodrich is talking about I think should come at a later time, because if both the point of view of the Department and the point of view of the company are presented at the same time we will get nothing but confusion, and I will ask the committee to bear with us a little bit on some of this cross-examination.

The CHAIRMAN. There will be that opportunity.

Mr. PARHAM. I have no intention of being reluctant. I simply try to be as exact as I can be, because I think the picture needs to be exactly defined and not to be painted in broad terms.

The CHAIRMAN. I think the committee understands that. May the Chair suggest, both to the witness and Mr. Cox, that if we proceed with less fencing between the two very able gentlemen and get down to brass tacks we will proceed more rapidly?

Mr. COX. Perhaps we can move on to something that is a little less controversial.

Senator KING. I would like that question answered, because I think that might save some cross-examination—as to whether this was a basic patent.

The CHAIRMAN. Why do you think it is a basic patent?

Mr. PARHAM. I consider it is a basic patent for the reason that the patent contains claims which, in my opinion, express the fundamentally important thought which Mr. Peiler had when he originated this new art of gob feeding. That thought, as I understand it, is the use of much more viscous glass than was ever used before in mechanical feeding, and the control of that glass so that it would hang up until the entire charge was in suspension below the orifice, whereupon the exact quantity would be cut off quickly by mechanical shears.

The CHAIRMAN. Am I correct in understanding that in the trade, so to speak, a basic patent is such a patent that, in the then current state of the art, it is necessary for the construction of any efficient machine to do the particular work that is required to be done?

MR. PARHAM. I don't know as I follow you, quite, Mr. Chairman. My thought is this, that a basic patent, in my opinion, is the patent which lies at the base of a new advance of some considerable magnitude.

THE CHAIRMAN. In the present state of the art and without which the art cannot be carried on in the most efficient manner?

MR. PARHAM. In that particular branch of the art; yes, sir.

THE CHAIRMAN. So that when you speak of this as a basic patent you mean by that that it is such a patent that any company which undertakes to engage in the manufacture of that type of glass for which this machine is used would not be pursuing a most efficient method of manufacturing it without the use of this patent in some form?

MR. PARHAM. Well, I think that happens to be true in this particular case, but you may have several different lines of developing it from a base.

THE CHAIRMAN. Certainly.

MR. PARHAM. You may have several different bases, and they all may end up with the same ultimate article, but the company that has the basic patent on the most efficient way is the fellow who is on top.

THE CHAIRMAN. He controls the industry. That is the point.

MR. COX. I would like to revert for a moment to a patent we were talking about a little earlier, 1,655,391, the stuffing patent; and I would like to have you tell the committee how wide you think the scope of that patent is so far as it relates to gob feeding.

MR. PARHAM. I think I can best tell the committee that in terms of the opinion in our case against the Shawkee Co. In the opinion of Judge Buffington, the formal title is *Shawkee Manufacturing Company et al. v. Hartford-Empire Company* (68 Fed. 2d 726). Judge Buffington, speaking of the invention of that patent, stated: "The functional invention of that patent was the swelling of a gob in suspension to desired shape and shearing such shaped gob in suspension."

That patent, as you see, adds to the earlier patent the thought that the charge is to be artificially shaped in a certain way; that is, by stuffing it, and that is the reason we call it the stuffing patent. The suit to which I have referred, Your Honors, was brought by us to stop the infringement of this patent by one of these air feeders, which was spoken of yesterday. The description of the court here shows that the invention applied to an air feeder even though the patent drawings showed a plunger feeder. I thought that might clear up some difficulty, that there seemed to be question as to a plunger feeder being one thing and an air feeder another. They are different species of the same invention which are covered by these Peiler patents. There are also some specific inventions under those broad inventions on each, but they are really not two absolutely different things.

MR. COX. Have you finished, Mr. Parham?

MR. PARHAM. Yes.

MR. COX. Would you say this patent whose scope you have just described is a narrower or wider patent than the heated-hood patent?

MR. PARHAM. It is a narrower patent.

MR. COX. Now, thinking in terms of machines, Mr. Parham, what kind of automatic feeders in use today are not covered by this stuffing patent just described?

Mr. PARHAM. You mean in use today—are you limiting that question, or are you referring to feeders which have been in use and which have been supplanted by this preferred form, because there are some of those?

Mr. COX. I am speaking, first, of the feeders which are in use today.

Mr. PARHAM. The feeders which I referred to previously—the stream feeders, and, if you want to call it such, the Owens device and the ribbon device and the Westlake device. In the other field this superseded our own commercial paddle feeder, which was our first commercial gob feeder.

Mr. COX. So that in terms of machines now in use the two patents cover relatively the same ground. I don't mean that the patents are the same, but the machines that fall under one also fall under the other; is that right?

Mr. PARHAM. Anything that falls under the narrower automatically falls under the broader patent, obviously.

Mr. COX. Now, when the narrower patent expires in 1945—doesn't it—

Mr. PARHAM (interposing). I believe that is correct.

Mr. COX. Anyone who is using one of your feeders on January 4, 1945, or anyone who is using one of the feeders, some other kind of feeder, which is covered by, which falls within, the claims of the patent which expires, say, on January 2, 1945, will not be free, on January 4, 1945, to continue to use that feeder without paying royalties to you, will he?

Mr. PARHAM. He will not be free of the monopoly granted by the Patent Office on the broader patent which came out later, and therefore we would probably claim royalties.

Mr. COX. You won't probably; you will, won't you, Mr. Parham?

Mr. PARHAM. I don't dictate the policy. I would suspect we would, though. I would advise it.

Mr. COX. I wanted to find out how strong your qualification was.

Mr. PARHAM. I would advise it.

Mr. COX. So that that monopoly would extend, then, for another 10 years, is that correct?

Mr. PARHAM. The monopoly on the later patent will extend for another 10 years, but the monopoly, which is a different monopoly, on the narrower patent, will have expired.

Mr. COX. But the broader monopoly will continue under the patent which went into the Patent Office in 1910 and came out in 1937.

Mr. PARHAM. Yes, sir; having started later, it will end later.

Representative SUMNERS. Will you develop that pretty well? That is a very important point, it strikes me, right on that point.

Mr. COX. You mean the length of time it was in the Patent Office?

Representative SUMNERS. You have an idea that is patented and the right to use that particular article, we say, will expire in 5 years. Then, from this answer, it seems to me that it is possible to go in and get a broader patent in which you can bracket in, maybe not only this one, but innumerable others, that people can't use. On what theory is that? I mean, it is rather important for us to know about it, I think.

Mr. COX. I would like to have Mr. Parham tell you about that.

Mr. PARHAM. Well, as I understand it, the theory of the patent law provides for the grant of a patent on each invention. If you have

two inventions you may have two patents, assuming they are both inventions and the Patent Office finds them so.

Now, an inventor may make his broad invention first—he always makes it first, as a rule. I shouldn't say "always." As a rule he makes it first. He applies for his patent application asking for a broad patent on that thing that he has invented. He goes on and works further to improve what he has made in the first place, and in the course of making that improvement he invents something further. He makes a second invention. He applies for his application on his improved invention.

Representative SUMNERS. Let me ask you a question, to get right down where we can understand it. Suppose there are four patents, a, b, c, and d, and they are approaching expiration, and there may be a number of things that can be made by people by using the patents a, b, c, and d, each. Now then, is it possible under our patent law for somebody to come along and take out another patent which would preclude these individuals who could use one of those pieces of machinery, with which you did a, b, c, and d? I don't understand your language but maybe you can get mine.

Mr. PARHAM. It is not possible for a later inventor to cover any of those four things, but if an earlier inventor had applied earlier than those four patents for his application, and his application had been delayed so that his patent came out after the patents on the four things you are speaking of, then it is possible that for a period there is a control of those four things. That is possible under the law.

Representative SUMNERS. Is that on the theory that he earlier applied for the patent and that you are now granting him the patent on an idea that probably antedated these four?

Mr. PARHAM. That is the idea, sir. The idea is based on the later patent.

Representative SUMNERS. I have got it.

Senator BORAH. Assume that Mr. A had made application for a patent. He is delayed for 10 or 15 years. Somebody else comes in and makes application and covers part of this territory that has been covered by the previous application. Does the Patent Office go forward and issue a patent while there is another application pending?

Mr. PARHAM. If the second man has an improvement and the first man is not claiming that same improvement; yes, sir.

Mr. ARNOLD. That would be part of the fencing process, wouldn't it?

Mr. PARHAM. No, sir; I don't understand that as a fencing process.

Mr. ARNOLD. A blocking process?

Mr. PARHAM. No; neither one in my mind. It is a simple operation of the patent laws, when you consider the possibility of the patent on the broad invention being delayed in the Patent Office longer than the one on the narrower invention.

The CHAIRMAN. And it makes no difference whether the two applications are associated?

Mr. PARHAM. It makes no difference.

The CHAIRMAN. But it is my understanding from your testimony that no application for a basic patent may be filed after the narrower patents have been issued and then be granted.

Mr. PARHAM. Well, the narrower patent would probably be a bar under the law.

The CHAIRMAN Yes; but if the application of the basic patent has been filed and subordinate patents were afterwards asked for and issued, their issuance would not be a bar to the issuance of the other patent.

Mr. PARHAM. You have correctly stated the matter.

Mr. ARNOLD. It might enlighten the committee, Mr. Cox, if we introduce the statement of stipulated facts in the Ethyl patent case. Isn't that a somewhat similar situation?

Mr. COX. Somewhat similar; yes.

Mr. ARNOLD. You might for the benefit of Representative Sumners—

Representative SUMNERS (interposing). I understand it now. I don't need it.

Senator KING. I'd like to ask one question, if I may be permitted. Suppose that A, B, and C do file application for patents which are covered by the broader patents which antedate that, and the Patent Office grants to A, B, C, and D patents somewhat narrower yet carrying out the same policy and the same thought that is in the broader patent. Then the broader patent is issued. Does not that, if it is issued to different and conflicting interests, destroy the A, B, and C patents? What is the effect? Does the broader one nullify the subordinate one or do they all exist?

Mr. PARHAM. If they are owned by different parties—

Senator KING (interposing). I am assuming they are.

Mr. PARHAM. The owner of the broad patent may use his own embodiment of the patent and any other embodiment he can think of except those patented to A, B, and C, who have the narrower patents. He cannot use those narrower embodiments because they are covered by the patents to A, B, and C. There can be a stalemate, then.

Senator KING. It seems to me, if you give a blanket patent, a broad patent, and then you attempt to give little, narrower patents that when the broad patent is granted it would supersede the narrower one, and the holders of those narrower ones could be debarred from exercising them.

Mr. PARHAM. As a matter of practice, I don't think they supersede really because if I have the broad patent and you have the narrower and improved patent, the chances are, the presumption is that your machine is going to be better than mine because it is an improvement on mine and there is a great incentive immediately for me to use your machine and as a practical matter I think the patent usually finds its own level and business will go on by some accommodation between us. I think we'd both be foolish if we didn't. I am not so certain of that as a general policy, but it is so in my own mind, sir.

Senator BORAH. Did you ever hear of a better scheme for manufacturing litigation?

Mr. PARHAM. Well, I would hardly say that the Patent Office manufactures litigation for the person who takes out patents. It is the fellow who comes out, who tries to take without payment the invention of the other fellow that stirs up the litigation.

Senator BORAH. That is always true.

Mr. ARNOLD. May I ask a question?

The CHAIRMAN. Pardon me just a minute, Mr. Arnold. Vice Chairman Sumners wanted to ask a question.

Representative SUMNERS. I see once in a while articles that have stamped on them "patent applied for." Does that afford any protection?

Mr. PARHAM. I don't think so; no, sir; it is not provided for.

Representative SUMNERS. Now, if a person manufactured an article where just a patent was applied for and afterwards, if it was hung up 5 or 6 or 8 or 9 years, and if he does get a patent and this other person has been making that thing, could anything happen in a law suit about it?

Mr. PARHAM. I don't think that notice is worth anything.

Representative SUMNERS. Well, apart from the notice, if a person applies for a patent and during the process of determination as to whether he is to have it, somebody manufactures an article that is covered by that patent, is there any possibility of any of these law suits?

Mr. PARHAM. No, sir; during the period that the application is in the Patent Office, any one who knows about the invention may apply it and be subject to no suit until the patent issues, and he is only liable for his acts after the patent issues.

Mr. ARNOLD. I'd like to ask a question simply to relate your previous testimony to testimony given yesterday, in an exhibit which is headed, "Memorandum on Policy of the Hartford-Empire Co."¹ I do not wish to raise now the testimony which has already been given as to whether that was or was not the policy. There is a statement of policy under "c" on page 2 of that memorandum which reads as follows:²

To secure patents on possible improvements of competing machines so as to fence in those and prevent their reaching an improved stage.

Now, that particular process referred to would be effectuated by just the thing which we are discussing, wouldn't it?

Mr. PARHAM. I don't think the two things are tied together very much, Mr. Arnold. My idea there—

Mr. ARNOLD (interposing). Wouldn't this fence in the basic patent by creating a stalemate?

Mr. PARHAM. It would prevent—the narrower patent would prevent the owner of the broader patent from using the improvement, that is correct.

Mr. ARNOLD. And don't you think that is what that sentence in that memorandum refers to?

Mr. PARHAM. Of course, it is not my memorandum. My idea is on that particular matter that we have always filed our applications with the idea of keeping our inventions ahead of the other fellow.

Mr. ARNOLD. I wasn't referring to whether this was your policy or not, because that was gone into yesterday, but don't you think that that particular sentence, whether it is or isn't your policy, refers to this process we have just been discussing?

¹ See "Exhibit No. 125," appendix, p. 771.

² Ibid., at p. 776.

Mr. PARHAM. Well, to my mind, it would refer to any taking of patents on your own inventions, for the purpose of developing the other man's machine, perhaps, for keeping up with the art in your own machines and in connection with your competitor's machine.

Mr. ARNOLD. This says "to secure patents on possible improvements of competing machines."

Mr. PARHAM. Yes, sir.

Mr. ARNOLD. So the discussion we have been having on this process probably related to that fencing in method, doesn't it?

Mr. PARHAM. I don't think the immediate discussion we have had really particularly applies to that one thing, Mr. Arnold. Maybe I don't understand you well. I am trying to be helpful in connection with it, but my thought there is that what was intended to be expressed in, maybe, office shorthand, was the idea that we were going to search constantly for the improvements that could be made in our own and competing devices so that we would always have the best situation and could furnish the best device.

Mr. ARNOLD. But this statement says, "to prevent their"—and that refers to competing machines—"reaching an improved stage."

Mr. PARHAM. That wouldn't be my idea.

Mr. ARNOLD. But it could be accomplished by this process.

Mr. PARHAM. Yes; it could be accomplished by that process, but, as a matter of fact, when you did accomplish that you would actually yourself have brought that machine to the improved stage.

The CHAIRMAN. Mr. Parham, isn't this all a very simple, practical matter?

Mr. PARHAM. I think so.

The CHAIRMAN. A patent is a very profitable right which is granted by the Government. The holder of the patent is naturally desirous of maintaining the monopoly which it grants as long as he can. Therefore, he would like to prolong it, if that were possible.

Mr. PARHAM. Yes, sir.

The CHAIRMAN. Therefore, when a patent is acquired by a large concern with large resources capable of establishing research bureaus and employing competent legal staff, isn't it a perfectly natural thing for such an organization to do what you have just described; namely, study intensively all possibilities of improving not only the patent which that concern itself owns, but every competing patent?

Is not the natural and inevitable result of that—and from the point of view of the patentee, the desirable result, whether or not it be desirable from the point of view of the public or from the Congress—that it affords the opportunity of the adroit, of the able, of the studious holder of a patent to do just exactly what Mr. Smith's memorandum said, fence-in competing patents so that the person who develops these improvement patents finds himself in a position to control the competing patent?

Mr. PARHAM. It doesn't, of course, control the competing patent, but he controls the next step in the art.

The CHAIRMAN. That is right.

Mr. PARHAM. And I say it is my belief that it is a very fine way in which to develop the art, because you have got to do something positive before you can do the negative thing of fencing.

The CHAIRMAN. But it is also a very fine and a very efficient way to concentrate control of the particular industry that may be involved.

Mr. PARHAM. It may be; if you have the brainier men that get the most inventions, you might possibly get the control.

The CHAIRMAN. You understand what we are after. We are merely interested in seeking the effect of these policies.

Mr. PARHAM. I realize that. I am trying to give you all I can on it.

Senator KING. I assume that the competing companies would also be utilizing their brains.

Mr. PARHAM. Absolutely.

Senator KING. And engaging in research in order to fence in their patents.

Mr. PARHAM. That is exactly what happens.

Senator KING. So that each company, each inventor, is trying to improve and to cover the field that some other inventor is trying to cover, so there is rivalry between companies in order to secure the very best improvements upon basic patents.

Mr. PARHAM. Well, I personally believe you are absolutely right about that.

Senator KING. I am not defending it, I am simply stating what is the view.

Mr. PARHAM. I also say if we didn't follow our policy of continuing improving, we wouldn't last very long; somebody would get ahead of us.

The CHAIRMAN. May I interrupt your examination, Mr. Cox, long enough to say that what impresses me is that we are now developing facts which show the operation of groups rather than persons. Mr. Kettering testified here the other day to the effect that we have entered the group era in the development of patents, and he pointed out the various research bureaus which are operated to illustrate that point of view. So here in the patent situation, therefore, we have this condition: The patent is a grant from the Government; it can't exist except by the act of Government. The corporation which holds the patent also arises by reason of a grant from Government, so here we have two artificial creations of Government which lay the basis and create the opportunity for the condition which has been developed by the Hartford-Empire Co. in the manufacture of glass containers.

Mr. PARHAM. I don't know as the corporate end of it has very much to do with it. One rich man would have hired all the rest of us to go to work, as well as the corporation.

The CHAIRMAN. But, as a practical matter, one rich man would not do that.

Mr. PARHAM. It is probably necessary to have the corporation; yes.

Mr. ARNOLD. You made one statement that interested me in answer to Senator King's question. You spoke of the opportunities that might develop to prevent these blocking situations if, because of competing companies, each invention and improvement of theirs is changed. That would indicate you believe as a matter of social policy the situation would be happier if there were more competing companies in glass.

Mr. PARHAM. I am trying to think it through, Mr. Arnold, with all its implications. Of course, the fact is that if this company of ours

hadn't come along there might not have been as many competing companies as there are now. I don't know of any reason why another company might not start and do what we did and make still further competition, and that might not be desirable. We think we have used our patents properly. We might have done a very selfish thing in a way, or it might not have been so selfish. Instead of licensing anybody on our basic inventions, we might have built a glass plant and made all the glass that would have been made by the gob-feeding method, and that we would have been entitled to do under our basic patent. I think we have created more competition than had we done that; a great deal more competition. Whether that would have been smarter or not I don't know; I don't pass on it, but it could have happened.

Mr. ARNOLD. Of course, I wasn't criticizing the policy, because if the Government gives you a monopoly I suppose we have no right to criticize you for using it.

Senator KING. Would it interrupt your procedure if I ask one question?

Mr. Cox. No; certainly not.

Senator KING. Reference was made to the long period that some of these patents were held in the Patent Office, to that application made way back in 1910 and the final patent wasn't obtained until along in the thirties. It seems to me that if your organization or any company contributes to those delays, there ought to be some penalty, and I was wondering if those delays there were in any way contributed to by your organization or its subsidiary.

Mr. PARHAM. I don't know. I would say they were not, sir. That is just the course of events. I personally have some ideas about changes that should be made.

Senator KING. Who filed those interferences which delayed the granting of the patents?

Mr. PARHAM. An interference is always declared by the Commissioner of Patents when two applications exist which have the same, or substantially the same, claim to invention. Neither applicant starts that interference, otherwise than by making his own claim to his own invention.

Senator KING. When this application was made adverse to the application of your corporation or your predecessor, or when the predecessor assigned his patent to you, did he use due diligence in trying to eliminate that interference and adopt all the process which would culminate in a patent?

Mr. PARHAM. It is my belief, sir, that he did.

Senator KING. I would be in favor, if I may be permitted to express an opinion now, of some policy under the terms of which those interferences may not be continued indefinitely, so that when a patent is applied for it may be issued at the earliest possible date.

Mr. PARHAM. I concur with your opinion heartily, sir, and I think that is one place where we really need a change in the patent law. I think the substance of the patent law is all right, but the procedure is bad in that respect.

The CHAIRMAN. Mr. Cox, you may now have the floor.

Mr. Cox. Mr. Parham, the mere fact, of course, that the Patent Office issues a patent doesn't mean it is valid, does it?

Mr. PARHAM. It is presumably valid until the courts find otherwise.

Mr. Cox. That is the point I wish to make, that it still must run the gauntlet of the courts; is that correct?

Mr. PARHAM. Very often it does, but frequently its validity is recognized by those who wish to deal in it.

Mr. Cox. But the law provides for judicial test.

Mr. PARHAM. Yes, sir.

Mr. Cox. Now take the patent you were talking about a moment ago, this heated hood patent. That was in the Patent Office for a long time, wasn't it?

Mr. PARHAM. Yes, sir.

Mr. Cox. Involved in a lot of interferences; and the Commissioner of Patents in the Patent Office finally refused to issue a patent on the application, and they were afterward directed to do so by the courts. Are those all circumstances which someone who wanted to contest the validity of the patent might raise?

Mr. PARHAM. Absolutely, sir.

Mr. Cox. You think they could, and, of course, it is right they should, raise them.

Mr. PARHAM. Even the decision of the circuit court of appeals is not necessarily binding in an opinion. It is persuasive, of course.

Mr. Cox. Now, Mr. Parham, will you just tell us who there is manufacturing glass containers in the United States today who could contest the validity of this heated hood patent in court?

Mr. PARHAM. They can contest the heated hood patent in court when, as, and if they are sued on the basis of that patent, or if they are threatened with suit on that patent I believe they can proceed under the Declaratory Judgment Act, and that applies to anybody who is threatened with suit.

Mr. Cox. Could any of your licensees raise the question of validity of that patent?

Mr. PARHAM. Our licensees probably would raise the question, yes, if they were sued for an infringement.

Mr. Cox. Could they legally?

Mr. PARHAM. They have no occasion to raise it while they are licensees.

Mr. Cox. Suppose they cease to be licensees, could they raise it?

Mr. PARHAM. If they cease to be licensees, they could raise the point; yes, sir.

Mr. Cox. Mr. Parham, I would call your attention to a provision in the license granted the Florida Glass Co., put in evidence yesterday.¹ I will read from it as follows:

So long as this license remains in force, the licensee agrees not to dispute the validity of the Letters Patent under which this license is granted, some of which are set forth in schedule E annexed hereto, so far as these patents apply to the methods and machines which are hereby licensed to the licensee.

I take it that means as to all of your licensees, they could only contest the validity of that patent if they or you should terminate their license; is that correct?

Mr. PARHAM. I think so. It says so long as the license is in force they shall not contest the validity of the patents under which they are licensed, insofar as they are in the licensed machinery.

¹ Entered as "Exhibit 118," supra, p. 405.

Mr. Cox. So if they want to contest the validity of that license or that patent, they have to run the risk of terminating your license and finding glass-making machinery elsewhere; is that right?

Mr. PARHAM. Surely. It is very much like certain other doctrines of law; you can't hold a right and dispute it at the same time. In fact, the law implies that same thing.

Mr. Cox. Of course, this patent right is a right which you acquire after the license is made in the case I am speaking of, isn't it? This patent was issued in 1937, and that license agreement was issued before then.

Mr. PARHAM. Oh, yes; I believe that is true, but they were licensed under the applications.

Mr. Cox. As soon as the patent comes out, you put the number of the patent on a plate on the machine, do you not?

Mr. PARHAM. We usually do; yes, sir.

Mr. Cox. And that binds the licensee by the estoppel set up by this provision in the license?

Mr. PARHAM. I believe so. There may be some cases that would take issue with that.

Mr. Cox. So the only people on that chart who could contest the validity of the patent today without making a change in their method of manufacture would be the three companies over there on the right, the three independent companies?

The CHAIRMAN. Will you identify the chart?

Mr. Cox. This is the chart that was introduced in evidence yesterday as "Exhibit No. 113."¹

Mr. PARHAM. Of course, it is true that any one of the three so-called independent plants which you show on this chart can contest the validity of any patent. It is true that any one of the licensees may contest that validity when they cancel or abrogate or breach their contract or are sued in infringement.

Mr. ARNOLD. That means they practically have to go out of business first, in respect to the methods they were using in conducting the business.

Mr. PARHAM. I don't know as they would go out of business. If they became infringers, they would still be in business or they wouldn't be infringers.

Mr. ARNOLD. You have title to the machinery in their plants in most cases and could take it out.

Mr. PARHAM. Yes, sir; but we have to proceed to the court to prove we are entitled to it.

The CHAIRMAN. It all amounts to this: That you have entered into contractual agreements with a number of individuals by which you have licensed them to use the patents which you hold, and, in turn, in these license agreements, you have bound each of them contractually not to bring litigation against them.

Mr. PARHAM. Yes, sir. It is not to bring litigation against us; it is not to dispute the title of the thing under which they are licensed. That is what it amounts to, and it is exactly what the law provides without this provision.

Mr. Cox. Of course, that is a kind of automatic estoppel, isn't it? It operates as soon as you put the patent number on the machine.

¹ See appendix, p. 762.

Mr. PARHAM. I would assert it would.

Dr. LUBIN. May I clarify in my own mind the statement you have just made? As I understood it, this licensee agreed to these things before the patent had ever been granted by the Patent Office; is that true?

The CHAIRMAN. I didn't understand that.

Mr. PARHAM. It appears to be the fact that as to the particular instance Mr. Cox was referring to the license was granted ahead of the issue date of that patent; yes, sir.

Mr. Cox. I think one more question and we will finish, if you don't mind bearing with me for a moment. Mr. Parham, I thought I understood you to say in response to some questions of the committee that it was your belief that Hartford-Empire Co. does not file applications in the Patent Office except with the view of obtaining patents?

Mr. PARHAM. I will say with very, very few exceptions I personally recommend that. I think we have filed a few applications upon details of machines which we were to put out where I had very, very grave doubt of patentability and I filed the application for the very purpose of making a record in the Patent Office that we had such a device at that time. The Patent Office has refused to grant patents, and I have concurred in that refusal; but the record is there in the Patent Office should I need it, if someone else tries again to get a patent on that improvement and stop our use of the invention.

Mr. Cox. Do you recall any specific cases where you filed applications for that purpose and not with the view of getting a patent?

Mr. PARHAM. I am sorry to say I can't tell you. I just recall there have been several instances when my doubt of the patentability was so great that I expected to do that when I filed the application.

Mr. Cox. You don't recall any instances where an application has been filed primarily for the purpose of throwing some other application into a series of interferences?

Mr. PARHAM. Have you something particular in mind? I will be glad to help.

Mr. Cox. Will the reporter read the question? I want an answer. (The last question was read.)

Mr. PARHAM. I can think of one occasion when we had purchased an application and we tried to get it in condition to get it into interference with another application of another party. Yes; I remember that. There may be other instances; I don't recall any right now.

Mr. Cox. Is this one you are speaking of now in 1924?

Mr. PARHAM. What I have in mind is the Headley-Thompson case, if that is what you have on your mind. It is the same thing.

Mr. Cox. I have a copy of a letter which purports to have been written by Mr. Brown in 1924. Mr. Brown was the chief patent counsel for Hartford?

Mr. PARHAM. Yes, sir; and vice president.

Mr. Cox. Written to Mr. Henry W. Carter, of Owens Bottle Co., of Toledo, Ohio. There is a paragraph which I shall read to you and I ask you if this is the same incident to which you refer. Perhaps I had better start at the beginning. [Reading:]

It seems rather likely that the negotiations with Whitall-Tatum will fall through.

Can you tell us what those were?

Mr. PARHAM. The negotiations with Whitall-Tatum were to obtain the right to a license; the negotiations for a license, to obtain a license under the Headley-Thompson applications which we had learned of in about 1920, and which we feared would cover and control the types of narrow neck forming machines which were being used by our licensees with our licensed feeders.

Mr. Cox. I will resume reading.

* * * the negotiations with Whitall-Tatum will fall through or be deferred in such a way that we shall have to stage a delaying fight. Mr. Byrnes says—

Is that one of the patent lawyers for Hartford-Empire?

Mr. PARHAM. Mr. Byrnes in this connection was not our patent lawyer. He has been employed in other connections.

Mr. Cox. What was he doing in this connection?

Mr. PARHAM. He was representing Whitall-Tatum Co.

Mr. Cox (reading):

Mr. Byrnes says that we cannot succeed in holding the *Headley* and *Thompson* cases in the Patent Office through interference proceedings, but that if we do not deal, he proposes to file divisional applications on matters covering commercial machines, and that he is sure of being able to issue dominating patents on the divisionals in spite of anything that we can do.

The next paragraph is the one I wish to call your attention to particularly. [Reading:]

For the purpose of forestalling any such program, we think it would be desirable, if possible, to plant a series of traps for such possible Headley and Thompson divisionals, the traps consisting of new applications to be filed to cover the several subject matters which Headley and Thompson seem likely to dominate.

Do you recall that? Is that the incident?

Mr. PARHAM. This particular letter was not written while I was associated with Mr. Brown, but I have seen the letter before in the file. I don't doubt Mr. Brown wrote it. So far as I can now recall, what he suggested was not done. It was just a skirmishing in the case of a fight and a deal.

The CHAIRMAN. Mr. Parham, in this connection perhaps it might be well to point out that the applications to which you refer as having been filed by your company are actually not filed by the company, are they? They are filed by individuals?

Mr. PARHAM. They are filed in the name of the individual in all cases. That is the law. They must be filed in the name of the first inventor.

The CHAIRMAN. I just wanted the record to show at this point that a corporation, as a corporation, may not be an applicant for a patent.

Mr. PARHAM. That is correct, sir.

The CHAIRMAN. Now, how do you choose your applicants, your personal applicants?

Mr. PARHAM. We don't choose our applicants. The applicants choose themselves by being the inventors. If we have doubts as between two of our employees as to which is actually the inventor, we usually call them on the carpet and find out their dates of conception and their various reasons for each asserting that he is the first in-

ventor, and we try to make the correct decision between the two in our Patent Department, and then file an application.

The CHAIRMAN. Do these employees receive any reward in addition to their salaries as employees?

Mr. PARHAM. I believe that there is a reward for men in certain salaried classes, a very small reward, but they are really not the source of our patents as a rule. Our inventions usually come out of our engineers; of course, their salary is based on their probable inventive ability, and they are frequently, or when it is available, offered stock at a low price, employee stock. I myself have been the beneficiary of that to a slight extent.

The CHAIRMAN. If it were your desire to file an application for a patent which would constitute an interference with some other application, how would you go about doing it? How would you choose the applicant in such a case?

Mr. PARHAM. I am not sure I have the question. Will you read it? (The preceding question was read by the reporter.)

Mr. PARHAM. Well, first of all, you would have to assume that I knew about the other man's application, which I probably wouldn't. I might under certain circumstances. If I thought that one of my inventors, or one of the inventors in our own employ, had made the invention earlier than the opposing applicant, I would file an application in his name, seeking interference so that he should have his invention rather than to have the invention belong to the opposite party. I would not make any different choice as between inventors in our own employ for that purpose. The only controlling issue is to find out who really made the invention in our own organization.

The CHAIRMAN. Do you maintain a staff to watch applications that may be filed in the Patent Office, so that you will keep abreast of the developments?

Mr. PARHAM. No, sir; we cannot follow the applications because they are not public, but we do receive in our office copies of the patents as they come out, and it is the duty of the several assistants in the Patent Department to go through their particular classifications and see if there is anything we should do anything about.

The CHAIRMAN. So one of the functions of your company is to keep in as close as possible touch with every patent that may be issued on any device that could be of possible use in your business?

Mr. PARHAM. I think it is fair to say we do keep up with the patent art as best we can. We think our business depends on it. We have to be up with the procession and a little ahead.

The CHAIRMAN. I understood you were going to offer some documents.

Mr. COX. That is a stipulation of Mr. Arnold's. I will bring that after lunch.

The CHAIRMAN. Judge Davis, do you wish to ask a question?

Mr. DAVIS. Mr. Parham, you described a procedure with respect to an application of a certain patent for which application was filed by the inventor in 1910, and which was in process over a long period of time, and I believe you said that your company purchased that patent claim for \$2,300.

Mr. PARHAM. Yes, sir.

Mr. DAVIS. When did they make that purchase?

Mr. PARHAM. That purchase was made in 1917. The circumstances were these. May I tell you a little more completely. We learned of this application by reason of being in interference with our own application, and we found that it had certain features that we thought we needed.

Mr. DAVIS. When you learned of this application for a patent, someone representing your company filed an interference?

Mr. PARHAM. No, sir; we did not file an interference. Only the Patent Office can declare the interference.

Mr. DAVIS. I understand that.

Mr. PARHAM. We made no effort to get the interference. It was declared and there we were. That was the first we knew of the Steimer application.

Mr. DAVIS. And no effort was made on the part of any one representing your company to get it placed in interference?

Mr. PARHAM. No, sir; no effort was made to interfere.

Mr. DAVIS. Was this inventor identified with some other glass company, or was he a wholly independent inventor?

Mr. PARHAM. He was a worker in glass, but not identified with any particular glass company; that is, he was not under any contract or agreement with any other company to transfer his inventions. He was an independent who had thought up this scheme and filed his own application.

Mr. DAVIS. And was not in the employ at the time of some other glass company?

Mr. PARHAM. He may have been actually working for some other glass company, but he was not inventing on the time of that company. It was an independent invention of his own, as I have understood it, sir. That was back a little before my time and I was speaking of these early proceedings from the record.

Mr. DAVIS. I believe you have agreements with all of your employees under which any inventions developed by them belong to the company.

Mr. PARHAM. Any invention in our particular field of glass.

The CHAIRMAN. If there are no other questions, the committee will stand adjourned.

(Whereupon, at 12:15 noon, a recess was taken until 2 p. m. of the same day.)

AFTERNOON SESSION

The committee resumed at 2:10 p. m. on the expiration of the recess.

The CHAIRMAN. The meeting will please come to order.

Are you ready to proceed, Mr. Cox?

Mr. Cox. I am, Mr. Chairman. I have finished with Mr. Parham for the time being, at least, if the committee has no questions.

The CHAIRMAN. Do any of the members of the committee desire to ask Mr. Parham any questions?

Senator BORAH. I wish you would explain so a layman can understand it what is meant by "fencing in."¹

¹ See "Exhibit No. 125," appendix, p. 771, at p. 780.

**TESTIMONY OF SIDNEY F. PARHAM, PATENT ATTORNEY,
HARTFORD-EMPIRE CO., HARTFORD, CONN.—Resumed**

Mr. PARHAM. Well, fencing in, as I think that term has been used and in a way I think a layman would understand it, means that from a patent sense you try to get not just the particular piece of machinery covered with a patent claim but a certain zone around that particular machine which you speak of as being fenced in as your property, and the other fellow fenced out. At least that is the way I would understand it. That means that if you have a broad claim by itself it may fence in, or you may fence in by half a dozen narrower claims of different types.

Senator BORAH. So that the enemy can't spread out too much?

Mr. PARHAM. So that the enemy can't break into your own little patented preserves—is the way I would understand the term.

Senator BORAH. That is all I desire to ask at present. He will be back, I suppose.

Senator KING. In any of those proceedings in the Patent Office in which your organization was interested did it pursue any course that might be denominated one of delay for the purpose of preventing a speedy consideration and determination of applications that were filed?

Mr. PARHAM. Speaking of the interference proceedings with relation to feeders that we were speaking of today, I think I can only generally answer that we did not delay. We had every urge on the contrary to hasten things, because we were trying to do business without our patents. On the other hand, to be perfectly candid I do know of one instance in which we were being more or less threatened with a very serious patent coming out on forming machines, in which we slightly delayed the issuance until we could make a trade with the man that owned the other patent. That is the only one I recall at the moment.

Senator KING. Coming to that instance where so many years elapsed from the filing of the application until the matter was finally determined in the circuit court of appeals, did your organization take any steps to delay proceedings either in the Patent Office or in any of the courts?

Mr. PARHAM. None that I recall, sir, unless you call the compliance with the almost mandatory rule of the Patent Office to make motions adding such other issues to the interference as you may need to avoid estoppels. That is mandatory, or you lose your rights. We made such motions in some of those cases, as I recall them now.

Senator KING. Were you interested in securing patents at the earliest date possible?

Mr. PARHAM. We were, sir, because we had our commercial machines out in large number; we had licensees who had taken our word that we were going to have patents and they had gone into business on that faith, and we had to make good, so to speak. We were being held up in these interferences and we desired more than anything else to get at least some of our basic patents out so we could protect that situation.

Senator KING. While this may not be germane to the testimony which has been given, interference matters have been referred to, and

this long case has been alluded to, what suggestion would you care to make as a patent lawyer to expedite matters and to prevent such long delays so that the patent, the application for which was made 10 or 15 or 20 or 25 years ago, will not expire until 1940?

Mr. PARHAM. I have some very decided opinions on those, entirely personal opinions as a patent lawyer rather than as a representative of the company. I think the interference practice can be greatly shortened by doing away with certain of the interlocutory appeals. At the present time there is a series of appeals allowed on motions within the Department. I think you can greatly shorten the time by having in the Patent Office, or connected with the Patent Office, say regional judges or examiners of interference, before whom you take your testimony and argue your cases as in open court.

We now have a deposition practice which is very long drawn out. After the decision of one of those judges, I would like to see a single appeal to a single patent appellate court. I believe in a single court for patents to have that jurisdiction as well as the jurisdiction in infringement cases. These are my personal ideas.

Senator KING. Speaking only for myself, it seems to me that those who are interested in obtaining patents and believe in the limited monopoly which the patent gives ought to be willing to and should contribute to some plan under the terms of which the applications for patents may be speedily determined because, if we are to delay those matters for 10 or 15 or 20 or 25 years, there will be a demand, in my opinion, for very radical modification of the patent laws.

Mr. PARHAM. I am entirely in accordance with that opinion, Senator, and I am very glad to do what little I can to help that.

Mr. ARNOLD. Your own definition of fencing in is not, then, that given in the memorandum entitled "Memorandum on Policy of Hartford-Empire Company," which reads as follows:¹

To secure patents on possible improvements of competing machines so as to "fence in" those and prevent their reaching an improved stage.

You wouldn't agree with that?

Mr. PARHAM. That is not exactly my idea of fencing in. I already have explained this morning, or tried to explain, that in the position in which we have found ourselves we have considered it good policy—I personally think it is sound policy—to try to develop along every possible avenue to get the best result we can for our licensees. Now, if we do that it means that we take a view of the competitor's machine; we see if it can be improved up to a point where it will be worth-while competition for our machine. If we can make that improvement and get the patent on it, we block off the other fellow or fence him out. We don't necessarily fence him in; we fence him out really of that particular improvement; but while we are doing it we ourselves are improving the art, and if we succeed in making that machine better than our own machine we have got that available to put out.

Mr. ARNOLD. Then, I take it there is a conflict between the written contemporaneous memorandum which we have introduced and your present definition of the policy.

Mr. PARHAM. Well, of course, sir, this is not my definition in the memorandum. It was written by Mr. Knox Smith.

¹ See "Exhibit No. 125," appendix, p. 771, at p. 780.

The CHAIRMAN. That is a good definition of fencing in, is it not?

Mr. PARHAM. I personally like my definition much better. Mr. Knox Smith liked the other point of view. I have a great respect for his opinion.

The CHAIRMAN. You are like the man with the basic patent—you cover a good deal more of the field than he.

Mr. PARHAM. I really don't think I do. I place a different emphasis on the words than the committeemen place on them. To me the idea is one of doing something positive in the way of development, rather than the negative thing of cutting the other fellow out. Now, you may incidentally cut the other fellow out.

The CHAIRMAN. The two things are identical. It is the reverse and the obverse of the same method, isn't it?

Mr. PARHAM. Yes; you can put it that way; but I prefer the positive side.

The CHAIRMAN. It is a nicer way of stating the same thing.

Mr. PARHAM. And I think it is a more exact way when you apply it to us.

Senator BORAH. Both propositions accomplish the same end.

Mr. PARHAM. Yes; they may accomplish the same end except I don't know how to block out anybody by doing nothing.

Senator KING. Each competitor is trying to improve, if he is in the business to succeed, trying to improve his mechanism and his art and to that extent he is trying to block out his competitor, and each competitor is working against the other fellow for the purpose of blocking out or getting the best in the art, so that he may get the trade. If he doesn't improve, some other organization may get the trade away from him, so there is constant rivalry between the competitors.

Mr. PARHAM. Yes, sir.

Senator BORAH. It is not always for the purpose of improving. It is sometimes for the purpose of preventing somebody else from doing something, isn't it?

Mr. PARHAM. I have never been conscious we have been proceeding along that line, if you are applying it to us.

Senator BORAH. I am not speaking of your particular company.

What I want to know is about fencing in, in general, how it is used by other companies. It is often used for the purpose of preventing somebody from developing their field, isn't it?

Mr. PARHAM. I would say if someone starts out to block someone else, he must make an invention. All he is trying to do is to make some money on that invention, and he may sell it to the other fellow, and he can use it if the improvement is worth anything. If it is not worth anything, you don't have to use it, so the thing finds its own place in the economic structure, as I see it.

Senator BORAH. I judge from the letter of Mr. Brown today that there are times when it is looking to individual interests.¹

Mr. PARHAM. As I explained this morning, that was one of the suggestions, as I understood it, in the course of a rough-and-tumble in which we were trying to get to a point where we could make a contract to obtain these rights we were afraid we would need in order to carry on our purpose. That is a little unfortunately expressed.

¹Supra, p. 455 et seq.

Mr. ARNOLD. Would it be correct to say, to summarize your statement, that they were, of course, in your organization primarily interested solely in making money, but they always lost out in favor of the more humanitarian policy?

Mr. PARHAM. Oh, I wouldn't say that.

Mr. ARNOLD. Generally, I will say.

Mr. PARHAM. No; I wouldn't say that. Mr. Smith testified yesterday, and I agree with him, we are not a charitable organization.

Mr. ARNOLD. The question was argumentative, so I won't ask you to answer it.

Mr. Cox. Two questions have been raised by the committee which I should like to ask a question about, if I may. In response to Senator King's and Senator Borah's questions I got the impression that you were suggesting that insofar as this fencing-in process is carried on, it is carried on as a part of a competitive contest between people in the same line of business.

Mr. PARHAM. I think that is what it usually is, if you are speaking of it generally; yes. Each fellow is trying to get the biggest place in the sun.

Mr. Cox. Is that the situation today with respect to your company so far as it carries on the fencing-in process?

Mr. PARHAM. Insofar as you say we are carrying it on. I don't like the word the way you use it, but nevertheless what we are doing is trying to maintain our position at the top of the pile so that we can pass on to our licensees better machinery, keep them right up to snuff, and incidentally make money for ourselves.

Mr. Cox. You are in the business of developing and perfecting glass-making machinery, obtaining patents on that, and licensing people under the patents; is that correct?

Mr. PARHAM. We are in that business and in the business of servicing and repairing. We give advice about other machinery.

Mr. Cox. Take the business of developing experimental work for obtaining patents on glass-making machinery and licensing under those patents, what other companies are in that who are your competitors?

Mr. PARHAM. My competitors may be, first of all, the builders of the Owens suction machine, I mean the more improved machine. As I told you before, the old patents are out.

Mr. Cox. That is the Owens Co.

Mr. PARHAM. If you are speaking of the feeding and forming end, I think Mr. Peiler has prepared a list for you of certain people that make forming machines and supply them to the trade. There is quite a list of them, some seven or eight people.

Mr. Cox. What about feeding machines? Who makes those and supplies them to the trade?

Mr. PARHAM. I think most of the people that make the stream feed now make them for themselves—the people that use them. I am not certain of that. I think all of those matters are on those lists that you asked Mr. Peiler to prepare.

Mr. Cox. I wasn't aware we had asked for that.

Mr. PARHAM. You asked for a list of those competing machines and competing processes.

Mr. COX. Is there anyone else who is in the business in this country today, that you are in?

Mr. PARHAM. Do you mean in the whole business or in the business as to tanks, in the business as to things separate? There are a number of people in tanks.

Mr. COX. Take first the whole business.

Mr. PARHAM. I think that several of the larger glass companies carry on the complete line of development. The Hazel-Atlas Glass Co. and the Owens Co., I understand, have very extensive experiments and development work done in connection with their own business and their own machines and their own processes. Now, individually, if you get down to the question of tanks, I would say we are not a competitor yet. We have had a lot of ideas. We haven't licensed any tanks of our own yet. We hope we are going to have a better one in the near future, and there are a number of people that make those. It is quite a competitive field.

Mr. COX. You haven't done much in the tank field?

Mr. PARHAM. We have done a lot of cutting and trying over the last 7 years; it has cost a lot of money, but we haven't got any money back.

Mr. COX. You haven't started the commercial exploitation?

Mr. PARHAM. No; that isn't out commercially yet.

On the question of lehrs, there are, I think, some 8 or 10 companies that are making lehrs of one kind or another.

Mr. COX. They are making them under your patents?

Mr. PARHAM. There are two companies that have made them under our patents. One of them is not making them under our patents now. There are a number that are making lehrs outside of our patents. There is a company we have alleged infringed our patents, and we have a recent holding of the court of appeals that they did infringe our patents. There are other companies that are making kinds of lehrs that differ from ours and are not covered by our patents and which are still used.

Mr. COX. I want to come back, Mr. Parham, to a question I asked in the first place, which is whether there is any other company in the country today which is engaged in the business of licensing feeding and forming machines?

Mr. PARHAM. I don't know whether I can fully answer that question. There may be a licensing of the suction machinery, which I understand you are classifying as a feeder and which I do not classify as a feeder.

Mr. COX. But you feel you can't answer that question?

Mr. PARHAM. No; I think Mr. Peiler can answer all those questions for you just like that, and I can't.

Mr. COX. I will leave that matter, because we are going to develop some testimony about these people by other witnesses.

I have one other matter, and then I will be through.

You spoke in reply to a question by Senator King about the interest which the owner of the application in the Patent Office feels in getting the patent out as rapidly as he can, so that he will have patent protection. Take the situation such as the one you described this morning, where the same man has two patent applications in

the Patent Office, one covering substantially the same machines but one narrower in scope than the other. That incentive doesn't exist to the same extent there, does it?

Mr. PARHAM. I can conceive of the case, certainly, where a man might wish to delay a broad application if he has two going on, but it is not always to an applicant's advantage to delay. Frequently it is more to his disadvantage. I am speaking generally. There are times when the art takes a new turn and goes off and leaves him before his patent ever gets out. He is foolish to delay in a case like that. There are other cases in which the cream is taken off his invention by somebody else during the period he is in the Patent Office. Now, there is the other side of the picture. If his monopoly starts later, he may pick up the most profitable period of use of that invention. You can't tell which it is going to be, because you can't tell when the next invention is coming out.

Mr. COX. If he gets his narrow patent first and his broad patent later, that may be an economic advantage to him.

Mr. PARHAM. It may be; yes, sir.

Mr. COX. I think I have finished with Mr. Parham.

The CHAIRMAN. Mr. Parham, you may be excused. We thank you very much.

(The witness was excused.)

The CHAIRMAN. Call the next witness please.

Mr. COX. In view of the nature of some of Mr. Parham's testimony, I should like to call a witness whose testimony will not take more than 5 minutes—Mr. McAllister.

The CHAIRMAN. Mr. McAllister, do you solemnly swear the testimony you are about to give in this proceeding will be the truth, the whole truth, and nothing but the truth, so help you God?

Mr. McALLISTER. I do.

TESTIMONY OF E. W. McALLISTER, PITTSBURGH, PA.

Mr. COX. Give the reporter your name and address.

Mr. McALLISTER. E. W. McCallister, Pittsburgh, Pa., and I am a lawyer.

Mr. COX. Will you tell us now what your qualifications are, particularly with respect to patent law?

Mr. McALLISTER. I am a graduate engineer; I am also a graduate of Cincinnati Law School. I practiced law in Cincinnati, and specialized in patents. In all my law practice I have always specialized in patent, trade-mark, and allied lines. I spent a number of years with the Westinghouse Co. at East Pittsburgh, and for the last 20 years I have been practicing general patent law in the city of Pittsburgh.

Mr. COX. Have you had any experience with patents relating to glass machinery, Mr. McCallister, and if so, will you tell us briefly what it is?

Mr. McALLISTER. Yes; I have represented a number of defendants in the litigations that you have heard of this morning. I was in one of the earliest glass cases brought by the Hartford-Fairmont Co. at that time against the United States Glass Co., and I have also been counsel and of counsel in other cases.

Mr. COX. Now I am going to show you two of the patents which we discussed this morning; the one, patent 572, which we referred to as the heated hood patent; and the other, 571, which I think we referred to as the Steimer patent; and I ask you whether you have any familiarity with those patents, whether you have had any experience in connection with them, and if so, if you will tell us what it is, very briefly.

Mr. McCALLISTER. Yes; some years ago and before these applications matured into patents, I assisted the then solicitor in the Patent Office in the attempt to avoid having the Commissioner issue these patents. You have heard of the suit this morning under 4,915, I helped the Commissioner, or, rather, the Solicitor of the Patent Office, in that case, in an effort to resist the outcome of the case.

The CHAIRMAN. By that, you mean the issuance of the patent?

Mr. McCALLISTER. The issuance of the patent; yes, sir.

Mr. COX. Now, Mr. McCallister, will you look at claim 5 of the claim of the Steimer patent, read it into the record, and tell us briefly as you can what, in your opinion, is the scope of that claim of the patent so far as it applies to the glass-making machines?

Mr. McCALLISTER. I am reading from Steimer patent 2,073,571, which issued March 9, 1937. Claim 5 reads as follows:

The method of forming masses of molten glass that comprises causing glass to flow from a parent body through an opening, causing successive portions of the glass, as they emerge from said opening, to hang freely below the opening, and then detaching the said successive portions of glass before they are received in any receptacle.

This is a broader claim than any that had theretofore issued to the Hartford-Empire Co. or their predecessor, the Hartford-Fairmont Co. In my opinion, it broadly defines the procedure of suspended gob feeding, or, as it is sometimes called, suspended charge feeding; that is, the procedure of making mold charges which is carried forward by the Hartford-Empire feeders here under consideration. It is of such scope that it involves also producing mold charges where the molten glass flows through an opening and is cut into mold charges while still in suspension.

Mr. COX. Well now, will you look at claim 30 of the so-called heated hood patent and do the same for that, Mr. McCallister?

Mr. McCALLISTER. By heated hood patent I assume you mean Peiler patent 2,073,572, which issued March 9, 1937. Claim 30 of that patent reads as follows:

The method of delivering gathers of fused glass from a melting furnace, melting container, or the like through a submerged outlet thereof, said method comprising the steps of maintaining the temperature of glass to be fed through the outlet adequately low to preclude the direct formation of a freely flowing glass current and to maintain such a state of viscosity in the glass that a volume of glass roughly corresponding to the gather to be delivered, collected by the outlet of the melting furnace, container or the like, is allowed to hang down and adapted to be cut off before such gather breaks off or continues flowing, and severing of such gather by mechanical shears closed to cut through the glass below and out of smearing relation with the outlet while said gather hangs down and before it continues flowing.

Claim 30 that I have just read is also a very broad claim. It is addressed to a procedure involved by the Hartford-Empire feeders here under consideration, and in my opinion is fundamental insofar as

that procedure is concerned. It is addressed to a little different angle of the procedure than is defined by claim 5, of Steimer, in that it involves temperature maintenance of the molten glass during the feeding operation, and it also specifically involves the use of mechanical shears for accomplishing the severance of the molten stream of glass in the mold charges while such glass is suspended from a glass-submerged orifice.

Senator KING. I understand what you have just read is your own language.

Mr. McCALLISTER. Yes. I should have said "end of quotation."

Mr. Cox. Mr. McCallister, taking those two claims together, I wonder if you would state shortly for us what is your opinion as to the scope of those patents, so far as they apply to the machines in use today.

Mr. McCALLISTER. Well, these two claims, whether they are contrasted or whether they are taken together, are very broad claims. You noticed the claim 30, that I read, involves no implement extending into or above the glass. This claim is, therefore, broad enough to cover, I believe, a form of feeding which has been referred to as the old "flow" feed, provided the cutting into mold charges is accomplished by shears located, of course, below the orifice.

Mr. Cox. Mr. McCallister, it was testified to this morning that that flow-feed method of feeding glass was in use in some places commercially. Do you know whether in any of the places where it is in use shears are close enough to the orifice so that that method falls within the claims that you have mentioned?

Mr. McCALLISTER. Yes; I have seen it operating at Ball Bros., and I am quite sure the claim would cover that procedure.

Mr. Cox. I have finished with Mr. McCallister.

Representative SUMNERS. Mr. McCallister, what are you reading from?

Mr. McCALLISTER. I read from the patents first, and then I read from my own notes, because I knew what I was going to be asked.

The CHAIRMAN. You described the Steimer patent first, did you not? That was the patent that was issued in 1927 or '28?

Mr. McCALLISTER. In 1937, on an application which was filed in 1910.

The CHAIRMAN. It was issued in 1937; the application was filed in 1910. It appears to be a very basic patent.

Mr. McCALLISTER. In my opinion it is, sir; yes.

The CHAIRMAN. Well, was the method there described in this patent of 1937 used in the industry prior to the issuance of the patent?

Mr. McCALLISTER. Oh, yes;

The CHAIRMAN. For how long a period?

Mr. McCALLISTER. To my own knowledge, 17 years.

The CHAIRMAN. By whom was it used?

Mr. McCALLISTER. This *United States Glass case* that I spoke of was predicated on just such a use by the United States Glass Co.

The CHAIRMAN. By whom else was it used?

Mr. McCALLISTER. Well, the Berney-Bond Co., which was sued at that time. They were using a feeder which operated within the broad terms defined by the claim which I read from the Steimer patent.

The CHAIRMAN. By whom is it used now?

Mr. McCALLISTER. I believe all glass manufacturers, and particularly those making the so-called containers that have been discussed here.

The CHAIRMAN. But under license now from Hartford-Empire?

Mr. McCALLISTER. So I understand, sir; yes.

Representative SUMNERS. May I ask a question? You say this process was used 17 years before the patent was issued to which you refer. The people who were using the process, were they using that under a prior patent?

Mr. McCALLISTER. No, Your Honor; I don't like to be pedagogical, but I think from what I have heard there has been a little misunderstanding here—

Representative SUMNERS (interposing). That is what I am trying to get straightened out. Somebody was using this patent 17 years—I mean, using the process 17 years before the patent was issued, if I understood your statement.

Mr. McCALLISTER. Yes; that is right.

Representative SUMNERS. Now, the people who were using the process 17 years before the patent was issued, were they operating under a patent?

Mr. McCALLISTER. They may have been. The United States Glass, which was my client—

Representative SUMNERS (interposing). Now, you don't know whether they were or not.

Mr. McCALLISTER. If you will just give me a chance, I will answer you. The United States Glass, who was my client, were operating under a patent. They were operating under a so-called Miller patent. It involved these same operations accomplished by a plunger, and it also employed what was called a blow back.

Representative SUMNERS. I know, but you are a patent man, and I am not. What I want to know is, Were the people operating under a patent who were using the process? Can't you answer?

Mr. McCALLISTER. I have answered; yes.

Representative SUMNERS. Now, then, were they precluded by the later patent to continue to use the process that they had been using 17 years before?

Mr. McCALLISTER. They would be subject to suit if that is what you mean by precluding.

Representative SUMNERS. I mean a successful suit. I know anybody can sue you, but I mean a successful suit.

Mr. McCALLISTER. You are asking me to pass upon the validity of the claim I have just read to you?

Representative SUMNERS. I am just hoping you can help us; I am not asking you to do anything.

Mr. McCALLISTER. The only answer I can give you, sir, is this: That these claims give an apparently broad protection to the Hartford-Empire Co.

Representative SUMNERS. I understood that.

Mr. McCALLISTER. The courts will determine as to whether or not that protection is proper protection by determining whether or not the claims that I have read to you are valid claims.

Representative SUMNERS. May I ask you another question, if you don't mind. Were the people who were operating under this process

17 years before the issuance of the patent sued for any reason? Were suits brought against them or did they quit using the old process? What happened when the new patent was issued?

Mr. McCALLISTER. When it was issued in 1937 all the people that were then operating, except the three noted on that chart and one other—the United States Glass should also be included with the three on the right hand of that chart [indicating]¹—were all licensees under the Hartford-Empire Co. The United States Glass Co. is incidentally still operating even in the face of these two patents from which I have read.

Representative SUMNERS. Thank you, sir.

Senator KING. I understand there is a controversy between the company which you represent as a lawyer and the Hartford-Empire Co., and your company was defeated.

Mr. McCALLISTER. No, sir; that is one of the cases that was won by the defendant.

Senator KING. Well, were you operating under this patent—was your client operating under the patent or under any patent? If so, to whom was it issued?

Mr. McCALLISTER. May I make a suggestion?

Senator KING. No; answer that question. Was your client operating under a patent?

Mr. McCALLISTER. The United States Glass Co., as I answered just a minute ago, was operating under a so-called Miller patent which covered a machine, and I think also a procedure, for forming suspended mold gobs under the action of a reciprocating plunger and what I have termed a blow back.

Senator KING. Then there was a controversy between your company and the Hartford Co., you contending that they were infringing the Miller patent, or they contending that you were infringing their patent?

Mr. McCALLISTER. Yes; the Miller patent never came into the controversy.

Senator KING. I am not interested in that controversy; I am only trying to find out whether there was a controversy between your company and the Hartford-Empire Co.

Mr. McCALLISTER. Well, there was this—

Senator KING (interposing). Was there that controversy?

Mr. McCALLISTER. Certainly there was the suit.

Senator KING. Now, why were you interested in going to the Solicitor? Why were you interested, and did you think that it was ethical—I am not making any comment one way or the other—in going to the Solicitor of the Patent Office and trying to prevail upon him not to issue a patent or to approve of an application?

Mr. McCALLISTER. Well, you misunderstood me absolutely and entirely, sir. Let me explain that again—

Senator KING (interposing). Did you go to him?

Mr. McCALLISTER. Yes, yes; but that was long after the *United States Glass Co. case*. The United States Glass suit was filed and tried in 1920 and 1921.

Senator KING. Well, what was it that you were trying to prevent the Solicitor from approving?

Mr. McCALLISTER. If you will just wait a minute—

¹ See "Exhibit No. 113," appendix, p. 762.

Senator KING (interposing). What was it? You can answer that. Was it an application for a patent and, if so, by whom?

Mr. McCALLISTER. The Hartford-Empire Co. had sued the Commissioner under 4915 to compel him to issue the two patents to which I have referred. Now, of course, the records of all suits in the Federal courts become public property.

Senator KING (interposing). Oh, we are all familiar with that.

Mr. McCALLISTER. And that is how I knew about it, and in an attempt to protect a client at that time against the issuance of what I believed to be improper patents, I asked—I think his name was—Hostetter if I could give him any help in connection with briefing his case before the Supreme Court of the District. He gladly accepted my help and I briefed the case for him.

Senator KING (interposing). I am not interested in that. I am just trying to find out what the controversy was and did the courts finally determine the validity of a patent. Reference was made by one of the witnesses today or yesterday that the case went to the circuit court of appeals here and that overruled the district court and affirmed the validity of the patent. Is that the patent to which you are referring?

Mr. McCALLISTER. Yes, your Honor; but the court did not confirm the validity of the patent. That was a case of 4915 against the Commissioner and—

Senator KING (interposing). Requiring the Commissioner to issue the patent?

Mr. McCALLISTER. Yes, sir; that is it, and these two patents resulted.

Senator KING. So there is a controversy between you as a lawyer and the lawyer of the other company as to who had priority under these patents?

Mr. McCALLISTER. No; I have no controversy with anybody as to who has priority.

Senator KING. Well, you claim the priority, do you, for your company?

Mr. McCALLISTER. No; I do not. We were contending that the Peiler—in the briefs that I wrote and in the controversy that you refer to between this Commissioner of Patents and the Hartford-Empire Co., the Patent Office had already held that the basic claims, those that I have read to you, were not patentable claims. This suit was to compel the commissioner to issue the patent with those claims in it. Now I was taking the side of the Commissioner and the Patent Office and I were agreeing that they were not patentable claims, but I had no controversy as between a client of mine and the Hartford-Empire Co.

Senator KING. As I understand it, there is no controversy between you and your client and the Hartford Co.

Mr. McCALLISTER. No.

Senator KING. You are all harmonious?

Mr. McCALLISTER. Well, I suppose I can't answer that "yes." That is a pretty big word because there very few of us that are harmonious with anybody else.

Senator KING. Are you here for the purpose of indicating that the Hartford Co. has not infringed upon your client and here in its defense or in its favor or what?

Mr. Cox. I feel in favor of the witness I should make a preliminary answer to that question. The primary reason he is here is we subpoenaed him and he came under legal pressure.

Mr. McCALLISTER. I might also add that they had a lot of my letters, and if I hadn't testified this way they would have read to me out of my letters. [Laughter.]

Senator KING. That is all.

The CHAIRMAN. Have you finished with the witness?

Mr. Cox. Yes. I think I should say in relation to the statement that the witness made in respect to the chart,¹ it is our understanding that the United States Glass Co., which he said should be up there, does not now produce glass containers.

Mr. McCALLISTER. Maybe not; just tumblers and pressed ware.

Mr. Cox. And that is the reason why that company is not on that chart.

Senator BORAH. I want to ask the witness a question. I think you need not return. You have been in the patent practice a long time. What do you understand by the term "fencing in"? Have you ever indulged in it?

Mr. McCALLISTER. I think patent lawyers have used that term for a number of years. I don't mean to say there is any definite significance to the term. I myself have always thought of it as building a paling fence around an invention. Now, I think of an invention as an entity, and an improvement is also an invention—it is an entity. If I have an invention of any sort, to fence in that invention I or my colleagues try to figure out as many ways of accomplishing the same or substantially the same result, and then we patent those ways, and as a result we have, instead of one patent, a number all bearing on the same subject matter, and we call that building a paling fence around it or, as you have termed it, fencing in.

Senator BORAH. In other words, if you have a patent, you undertake to surround that by other inventions, as nearly as practical, so as to confine it within a certain limited area.

Mr. McCALLISTER. Well, I wouldn't say confine it, but so as to make your protection of the general idea as broad as possible. You see, when you are talking or thinking of building a paling fence around something or fencing it in, you are thinking of confining, yes; but the patent attorney's idea is to get as many patents on the general idea as he can for the purpose of widening out the scope of his patent protection. Is that clear?

Senator BORAH. I understood what it meant to fence in cattle and horses, and so on, and I assumed that you were trying to limit the operation of a particular patent by patenting other ideas as near to it as you could get them without infringing.

Mr. McCALLISTER. That would not be my idea, sir, and very often, and I think most often, the patent attorney who is working for a client that can afford to take out a number of patents is merely thinking of the scope of the protection that he can get. Now, he may have nobody else's invention in mind; he may know of no one else's invention, and in 99 cases out of 100 that would be the case.

Senator BORAH. But I am speaking now of a person who wants to deal with another person who has a patent. They have spoken here

¹ See "Exhibit No. 113," appendix, p. 762.

about fencing in this or that patent belonging to someone else than those who are doing the fencing.

Mr. McCallister. The term could be used in that way. I never so used it. But under those circumstances you would undoubtedly have to know the subject matter of the adversely owned patent, and then you, yourself, and those colleagues who have inventive turns of mind, would direct their energies, their inventive energies, if you can consider invention as an energy—they would direct their inventive energies toward that particular thing covered by the adversely owned patent, with the hope of building patents around it, and therefore overlaying or at least overlapping such field of invention as the adverse owner of the patent might also think of.

Representative Sumners. He couldn't expand?

Mr. McCallister. No; you are trying to prevent his expansion by really foreseeing the field that he would expand into, and covering that field. It is just exactly, Senator, as if we were staking out claims around a gold mine. Now you hurry out to the productive claim and you stake out claims around that gold mine, and in that way prevent the owner of the productive claim from expanding to the adjacent claims.

Senator Borah. I understand that now, but I want to read the statement here to which I was referring when I asked the question in the first instance. It says that the main purpose of securing patents is this:¹

In taking out patents we have three main purposes: (a) To cover the actual machines which we are putting out and prevent duplication of them. The great bulk of our income results from patents. Between a feeder protected by patents and one not so protected there is the cash difference between one ordinary manufacturing profit of say \$1,500, and a royalty return of at least \$30,000 over 8 years; (b) to block the development of machines which might be constructed by others for the same purpose as our machines, using alterative means.

Now the fencing-in process comes in there, doesn't it?

Mr. McCallister. That would be what I just referred to, staking out your claims around the productive mine with the idea of blocking expansion of the mine owner or, from the standpoint of a patent, it seems to me that you would be trying to foresee the possible expansion or the possible improvements that might be made on the invention covered by the adversely owned patent, and in that way block the adverse owner of the patent from taking out improvement patents.

Senator Borah (reading):²

(c) To secure patents on possible improvements of competing machines so as to fence in those and prevent their reaching an improved stage.

Mr. McCallister. Of course, I think that would be an impossible thing for anybody to do. I have heard that letter read several times this morning, and I think the man who wrote it must have been an optimist, because we can't—nobody can foresee what somebody else is going to invent. Now, he can only try to out-invent the other man, but that is all he can do.

Senator Borah. It says "to secure patents on possible improvements of competing machines." Now, if you have in mind a competing machine, you undertake to determine what are the possible improvements which may be made to limit the operation of that machine.

¹ See "Exhibit No. 125," appendix, p. 771, at p. 780.

² Ibid

Mr. McCallister. Not to limit; no; but you try to foresee what the possible improvements on that machine would be to make it a better commercial machine, and then you try to patent those improvements in order to prevent the owner of the patent from getting patents on those improvements.

Senator BORAH. From developing his patent?

Mr. McCallister. Yes; from developing his patent. Now, as I say, the man who wrote that letter must have been an optimist, because it would be just hit or miss. No two men invent the same way, just as no two men think the same way.

Mr. ARNOLD. Could you put it this way: This fencing in process can be used as a defense against others, as was testified in the General Motors hearing, or as an offense by which you attack others, as there has at least been some testimony here, and that the defensive method is a whole lot easier to defend as a matter of public policy than the offensive method.

Mr. McCallister. Well, I don't know that public policy enters into it. I think that every patent lawyer in this country has been guilty at one time or another of trying to do both.

Mr. ARNOLD. I wasn't speaking of patent lawyers, because I conceive they must represent their clients and give the best benefit of the law as is. I was only speaking of the public policy of the law itself.

Mr. McCallister. Well, you know we live in a world of live and let live, and I think that each one of us is trying to build up the best that we can get for ourselves and for our clients. Therefore, I don't see public policy in it at all.

Mr. ARNOLD. You don't see a difference in policy between the automobile situation in patents and the Hartford-Empire situation?

Mr. McCallister. Both are operating under the law.

Mr. ARNOLD. But isn't there a difference in policy?

Mr. McCallister. There is a difference in policy, that is very clear, but they are both operating under the law and I don't see why I should be called upon to make a distinction of the morals in the situation.

Mr. ARNOLD. I wasn't calling on you for morals; it was simply a question of economic policy. However, I withdraw the question.

The CHAIRMAN. As I understand the description which you have given us, Mr. McCallister, it may be stated briefly this way: Just as a typical case, let us assume there are two machines, A and B, which perform generally the same function and serve generally the same purpose but are covered by different patents.

The owner of A, under the system which has been described here from the beginning of these hearings, and the owner of B, each undertakes to study the effect not only of his own patent but of the competing patent, and if his research laboratory is sufficiently able and his lawyers are sufficiently able he will endeavor to study the improvements which the other competing patents are susceptible of, and secure the patents upon them in order to prevent the holder of the other patent from expanding his business without first dealing or obtaining a license from the other man.

Mr. McCallister. That is exactly right. I tried to state the same thing.

The CHAIRMAN. And that is the process of fencing in.

MR. McCALLISTER. That is one process of fencing in. The other is to fence in your own invention.

The CHAIRMAN. And that was the process of fencing in which was described in this very clear memorandum from which Senator Borah was reading, and it has been practiced in industry generally.

MR. McCALLISTER. Oh, I think so.

Representative SUMNERS. One reason you fence your own in is to keep the other fellow from running a fence first.

MR. McCALLISTER. It is just exactly like staking out a lot of claims in a gold field.

The CHAIRMAN. Or fencing in a water hole on a ranch.

MR. McCALLISTER. That's right.

Senator KING. Senator O'Mahoney referred to A and B, each of whom had a patent, and each of whom tried to fence in by adopting such protective measures as he deemed proper, by finding what improvements, through his research laboratory, he might feel necessary. Suppose there is not a B, but there is just an A. Would not the A try to fence in by watching the development of the art and the development of the industry, and if he thought that his machine, though perhaps it was the best and most effective of any in operation, might some day be superseded by some other company not then in existence, would he not try to make improvements upon the machine which he had?

MR. McCALLISTER. Oh, yes; and that is done every day.

Senator KING. Are any of the great inventions and those who have them satisfied with them and regard the inventions as perfect even though they have no competition, or are they trying to improve them, anticipating that through technological development, the arts and sciences, some day somebody will beat them to the market and get the market away from them unless they make improved equipment?

MR. McCALLISTER. I spoke of being with the Westinghouse Co. At the time I was there the steam turbine was being developed. There were two lines of development, one by the Westinghouse and one by the General Electric Co., and each of those companies was doing just exactly this fencing in from both standpoints. We were trying to broaden out our own protection and we were trying to prevent developments along the line of the other turbine by patenting what we thought would be the probable commercial developments of the other turbine.

Senator BORAH. Did you ever represent a client who had been fenced in?

MR. McCALLISTER. I shouldn't wonder.

The CHAIRMAN. Are there any other questions?

Thank you, Mr. McCallister.

(The witness was excused.)

Will you call your next witness, Mr. Cox?

MR. COX. Mr. Levis.

The CHAIRMAN. Do you solemnly swear that the testimony you are about to give in this proceeding shall be the truth, the whole truth and nothing but the truth, so help you God?

MR. LEVIS. Yes, sir.

**TESTIMONY OF WILLIAM E. LEVIS, PRESIDENT, OWENS-ILLINOIS
GLASS CO., TOLEDO, OHIO**

Mr. Cox. Mr. Levis, will you give the reporter your name, address, and occupation?

Mr. LEVIS. William E. Levis. I am president of the Owens-Illinois Glass Co. My address is 2104 Parkwood, Toledo, Ohio.

Mr. Cox. Will you tell us now briefly, Mr. Levis, what the nature of the business of the Owens-Illinois Glass Co. is?

THE LARGEST GLASS PRODUCER IN THE WORLD

Mr. LEVIS. The Owens-Illinois Glass Co. manufactures glass containers, tumblers, tableware through a subsidiary, the Libbey Glass Co.; it manufactures tin containers through the Owens-Illinois Can Co.; it manufactures glass brick and insulators through a division called the Insulux Products Division. It also has a subsidiary on the Pacific Coast called the Owens-Illinois Pacific Coast Co., which manufactures glass containers west of the Rocky Mountains.

Mr. Cox. Considering glass containers for the moment, Mr. Levis, does it manufacture a full line of glass containers? By that I mean all different types.

Mr. LEVIS. It manufactures all known types.

Mr. Cox. Just give us some idea of the size of your company, Mr. Levis. Can you tell us what the balance-sheet assets were as of the close of business in the end of 1937?

Mr. LEVIS. I have it for October 31 of this year. I jotted it down.

The CHAIRMAN. How long have you been president of the company?

Mr. LEVIS. Since January 1930, sir.

Mr. Cox. I am going into some of that history.

Mr. LEVIS. The capital and surplus, net worth, of the company on October 31 of this year was \$63,866,000.

Mr. Cox. Your company, as compared with other companies, is rather a large producer of glass containers, isn't it, Mr. Levis?

Mr. LEVIS. Yes, sir.

Mr. Cox. In fact it is the largest, and produces about 38 or 39 percent of the total?

Mr. LEVIS. That is about 35 percent for the company east of the mountains.

Mr. Cox. What figure would we get if we put in the company west of the mountains?

Mr. LEVIS. About 38.

Mr. Cox. If you take the two of them together?

Mr. LEVIS. If you don't mind, I will treat them as one.

Mr. Cox. I would prefer to have you do that, Mr. Levis, if you will. It distributes the glass containers nationally, of course, and sells them everywhere?

Mr. LEVIS. Yes.

Mr. Cox. Mr. Levis, I don't know whether you have seen the chart that we had marked yesterday.¹

Mr. LEVIS. I have a copy of that.

Senator KING. Might I ask a question? I would like to know something about your assets. You have given the sum of \$63,000,000. What part of that consists of patents, and what value do you at-

¹ "Exhibit No. 113," appendix, p. 762.

tribute to them? What part to bricks and mortar, to machinery and plant, and what part to cash or liquid assets?

Mr. LEVIS. Our current assets, sir, are about \$30,000,000 net; that is, assets after current liabilities, and we have about \$79,000,000 in plants with a reserve for depreciation to bring that down to about \$48,000,000 net. Our patents are on at their actual cost, I think three or four hundred thousand dollars, which was the cost of securing the patents.

Senator KING. Your liabilities are \$30,000,000, did you say?

Mr. LEVIS. No; our net assets.

Mr. Cox. Referring again to the chart introduced yesterday in evidence as "Exhibit No. 113,"¹ I call your attention to those plants which are shown at the end of the lines radiating from the Owens-Illinois Glass Co. and I ask you if those are plants which your company operates. Is that correct?

Mr. LEVIS. They are plants which we own, but not plants which we operate.

Mr. Cox. There are some there you aren't operating, but you own them all?

Mr. LEVIS. Yes, sir.

Mr. Cox. Which ones aren't operating?

Mr. LEVIS. Going across the top backwards, that is, that is down the curve counterclockwise, we operate the plant at Los Angeles, at Oakland; the Evansville plant hasn't operated in 10 years.

Senator KING. Is it obsolete?

Mr. LEVIS. Yes, sir. The Terre Haute plant hasn't operated in the last 2 or 3 years.

Senator KING. Obsolete?

Mr. LEVIS. No, sir; it is equipped and could be operated if there were sufficient business. The Chicago Heights plant is a very small operation, a hand-blown plant.

Mr. Cox. Perfume bottles?

Mr. LEVIS. Gadgets for bending machines and items of that type. The Glassboro plant was abandoned in '29 and is now a cap factory, and operating as such. The plant makes plastic and metal closures. The San Francisco plant was abandoned when the Oakland plant was put into operation.

Senator KING. Is that obsolete?

Mr. LEVIS. It has been torn down, sir, and the equipment has been moved to a new factory in Oakland.

The Clarksburg plant hasn't operated for 15 years.

Mr. Cox. Is that obsolete?

Mr. LEVIS. Yes, sir; it is dismantled.

This is accurate insofar as our published data are concerned. I don't consider the chart in error.

Mr. Cox. I am glad to get that statement so we can see what the situation is in each one of those.

Mr. LEVIS. I might volunteer in connection with your discussion today—it means nothing to me—that in a number of these plants we have no Hartford equipment. In other words, if you use those as contrasted to the other side of the page, we have no Hartford equipment in several of these plants. I made these data: of the 17

¹ Appendix, p. 762.

plants, 11 are operative and 6 of them have Hartford equipment. The others are suction plants, solely.

Representative SUMNERS. Who controls those suction patents?

Mr. LEVIS. Our company did, sir, but I don't think there is much left to them.

Mr. Cox. Since that question has been raised, I might ask you when the basic patent, if you recall, on suction machines ran out.

Mr. LEVIS. I would say we had no very important patents after 1929.

Mr. Cox. There are some patents existing today which cover improvements on machines; is that right?

Mr. LEVIS. Yes, sir; and one rather basic patent on the stationary pot.

Mr. Cox. The pot revolves now?

Mr. LEVIS. The pot has always revolved, and we hoped that it would stop, but we haven't yet made it stop.

Mr. Cox. You can't work that patent?

Mr. LEVIS. We are working it on small machines, but not on large ones.

Senator KING. Did you say 11 of those plants you operated, and 6 used the Hartford equipment?

Mr. LEVIS. And then only partially, sir. At our Alton plant, the largest in the world, we have 10 furnaces and only 2 of them have Hartford equipment, and at our Huntington plant there are only 2 out of 5, and at Streator there is only 1 out of 11, so that in 6 plants a very small proportion of our equipment is Hartford equipment.

Representative REECE. Mr. Chairman, may I ask if the requirements with reference to licensing and royalties have restrained you from using the Hartford equipment in your plants?

Mr. LEVIS. No, sir; we believe our own development is superior to the Hartford's.

Mr. Cox. Of course, you do have a license under the Hartford?

Mr. LEVIS. We can make anything, but we only use it for a few things.

Mr. Cox. It is an unrestricted license, but you use it only for a few things. That has always been true?

Mr. LEVIS. It has always been true.

Mr. Cox. Does your company own any stock, Mr. Levis, in any other glass-producing company?

Mr. LEVIS. No, sir.

Mr. Cox. Does it own any stock in companies which use glass containers?

Mr. LEVIS. No, sir. Its only stock investment is the stock investment made about 1932 in the Container Corporation, and some stock in the Pennsylvania Sand Co. which was taken in the sale of some sand properties.

Mr. Cox. That brings me, really, Mr. Levis, to my next question, which is this: Would you describe your company as an integrated company? Do you own your raw materials, and do you manufacture a great many other things besides containers which you use in connection with the sale of your materials?

Mr. LEVIS. We tried to do that, but now we manufacture very little of our raw materials. We sold our paper plant and sold our sand operation and received shares. We have jointly with the Libby-

Owens-Ford Glass Co. a half interest in about 150,000 acres of gas property, leases, and in fee, in and around Charleston, W. Va., which supplies the gas for their plate-glass factory at Charleston and our bottle factory at Charleston, and we likewise have gas properties at Clarion, Pa., which we acquired from the former owners of that company.

Mr. Cox. You said a moment ago you made caps now for bottles, and you still make boxes to pack them in?

Mr. LEVIS. Yes; we are probably the largest manufacturer of boxes.

Mr. Cox. You not only make those for your own use but sell them to others?

Mr. LEVIS. Yes.

Mr. Cox. But you regard your business as primarily that of manufacturing and selling glass, is that correct?

Mr. LEVIS. Yes—a very small proportion of our corrugated manufacture for outside sales.

Senator KING. What do you mean "corrugated?"

Mr. LEVIS. Corrugated packages for the packaging of our glass containers.

Mr. Cox. Mr. Levis, I would like to have you tell us a little bit about your personal history in the glass business. You began with the Illinois Glass Co., didn't you? Is that your first connection?

Mr. LEVIS. Yes.

Mr. Cox. How long were you with the Illinois Glass Co. when it existed as a glass-producing company?

Mr. LEVIS. Well, I guess I was always with them. My grandfather started it 70 years ago. My family were always in it, and I started to work when I finished school in '13, and I was president of the company a short time after I came out of the Army.

Mr. Cox. About 1920?

Mr. LEVIS. I guess '22.

Mr. Cox. From that point on you were president of the company, and that was a manufacturing company?

Mr. LEVIS. Solely manufacturing and selling.

Mr. Cox. And solely glass containers?

Mr. LEVIS. No; it sold everything, but we used to say from the formula to the sales; we sold labels and cartons and everything except what the user of the bottle put in it.

Mr. Cox. You didn't make or sell any glass-making machinery?

Mr. LEVIS. No, sir. We licensed machines from others.

Mr. Cox. You were a licensee at one time both of the old Owens Bottle Co. and of Hartford-Empire?

Mr. LEVIS. We were one of the original licensees of Owens, and in 1919 we took a Hartford license.

Mr. Cox. That company was merged in 1929 with the Owens Bottle Co.; is that correct?

Mr. LEVIS. Well, its assets were acquired by the Owens Co.

Mr. Cox. It continued to exist after that for some time?

Mr. LEVIS. Yes.

Mr. Cox. What function would you say it served after that?

Mr. LEVIS. It was more or less an investment trust or a holding company who had investments in the glass industry, in the businesses of customers.

Mr. Cox. Was the stock of the Illinois Glass Co. widely or closely held?

Mr. LEVIS. There were 135 stockholders. They were practically all members of my family or employees of the company.

Mr. Cox. I see. Would you object if from time to time in the course of my examination I should refer to that group as the Levis group?

Mr. LEVIS. No, sir.

Mr. Cox. It may make it easier for both of us if we treat it that way.

That company, as you said, continued as a sort of investment trust until a rather recent period, 2 or 3 years ago.

Mr. LEVIS. No; in August of this year the directors submitted to the shareholders a plan of liquidation. The liquidation took place in September.

Mr. Cox. And the company has been dissolved?

Mr. LEVIS. Liquidated in kind. All of the stock distributed to the stockholders in kind. That is the Illinois Glass Co., which sold its assets to Owens and became Owens-Illinois.

Mr. Cox. So that the business which was formerly carried on in the manufacture of glass, the business of the Illinois Glass Co., from 1929 on, has been carried on by Owens-Illinois, is that it?

Mr. LEVIS. Yes. As I always thought of it, we sold our brick and mortar and inventory and accounts receivable for securities in another company. Instead of having those, we owned securities in the company that had them.

Mr. Cox. What position did you first occupy in Owens-Illinois?

Mr. LEVIS. I was vice president and general manager from April. Their shareholders' meeting, I think, was about the 21st of April 1929, in which their shareholders ratified the purchase; and then in January, between the 10th and 15th, I was elected president.

Mr. Cox. You said a moment ago that the stockholdings which were held by the Illinois Glass Co. included stocks in other glass-producing companies. Did I understand you correctly?

Mr. LEVIS. And in various businesses that we were familiar with and thought would be good investments.

Mr. Cox. And those securities have now, you said, been distributed in kind to the stockholders, and are largely held by what we called a moment ago the Levis group?

Mr. LEVIS. Yes.

Mr. Cox. Would you tell us one or two of the glass-producing companies in which the Levis group now has stockholders?

Mr. LEVIS. They owned shares in the Owens-Illinois Glass Co., the Hazel-Atlas Glass Co., the Anchor Hocking Glass Corporation, the Thatcher Manufacturing Co., and the Kimble Glass Co.

Mr. Cox. What is the Kimble Glass Co., Mr. Levis?

Mr. LEVIS. The Kimble Glass Co. is a small company in New Jersey who manufactures lime glass tubing and cane and rod for Bureau of Standards specification apparatus, for homeopathic vials, towel bars, and various items of that kind.

Mr. Cox. There was no stock in Hartford-Empire Co. owned by the Illinois Glass Co.?

Mr. LEVIS. At no time, so far as I can recall, was anyone associated with the Owens-Illinois Co. in any principal capacity, nor were the Illinois Co. ever shareholders in Hartford.

Mr. COX. You would make the same statement with respect to each member of the group you talked about as the Levis group?

Mr. LEVIS. I wouldn't know the minor people, but I know my uncles and father had no stock.

Mr. COX. The immediate family had no stock?

Mr. LEVIS. That is right.

Mr. COX. Would both of those answers apply so far as any stockholdings in the Corning Glass Works is concerned?

Mr. LEVIS. Yes, sir.

Mr. COX. Can you tell us how much of the outstanding stock of the Kimble Glass Co. the Levis group holds?

Mr. LEVIS. About 62 percent.

Mr. COX. Do you know whether the Kimble Glass Co. owns any stock in the Corning Glass Works?

Mr. LEVIS. I know they don't own any stock in any company other than one small subsidiary. I think they did have at one time some other stocks, but they have none now.

Mr. COX. You don't think at that time they had any stock in Corning Glass Works?

Mr. LEVIS. I know they never owned any in Corning.

Mr. COX. Or Hartford?

Mr. LEVIS. That is right.

Mr. COX. Now take the Thatcher Manufacturing Corporation; that is a company engaged in manufacturing glass containers, largely milk bottles, isn't it?

Mr. LEVIS. Yes; and they have a subsidiary, the Olean Glass Co., which manufactures a general line.

Mr. COX. Could you tell us what percentage of the outstanding stock of that company the Levis group owned?

Mr. LEVIS. They owned less than 10 percent.

Mr. COX. Can you give us a limit in the other direction, too?

Mr. LEVIS. They owned 10,000 shares of the stock at the maximum, and certain individuals owned shares personally. I explained to the S. E. C. in detail, gave them a lengthy report on the whole transaction, and they ruled it was less than 10 percent, even though they knew of the Kimble interests.

Mr. COX. When you add the Kimble interests, is it more than 10 percent?

Mr. LEVIS. There was no title to it so far as the same people were concerned. Remotely, we might have gathered everybody together.

Mr. COX. You mean the only chain there was the fact that one and the same group owned 60 percent of the Kimble, and Kimble owned a small percent?

Mr. LEVIS. No; a corporation in which certain individuals are interested own 60 percent of Kimble.

Mr. COX. And Kimble owned a certain percentage of Thatcher?

Mr. LEVIS. Yes.

Mr. COX. Does the Levis group now have a representative on the board of directors of the Thatcher Co.?

Mr. LEVIS. We never had a representative except insofar as Mr. William Mandeville, who was on the board, might have been considered our representative.

Mr. Cox. That is what I was going to ask you about, Mr. Levis. I am going to show you a letter which was written by you to Mr. R. H. Levis, dated July 25, and I call your attention to the last paragraph there. Will you have a look at that?

Mr. LEVIS. Yes, sir.

Mr. Cox. Will you tell us just to what extent, to what degree, Mr. William Mandeville was a representative of the Levis group?

Mr. LEVIS. I know he was a young lawyer in Elmira, and he has been a friend of mine for a good many years. One of their older directors died, and they wanted to select someone, and we, among us, had a large block of shares, and they asked our opinion, and we thought he would be fine.

Mr. Cox. Do you regard him as representing your interest at all?

Mr. LEVIS. We have never regarded anyone as representing our interest in anything, sir.

Mr. Cox. I was rather puzzled by this expression you used in the letter, in which you say:

Mr. William Mandeville is going on the Thatcher board, and I have expressed the desire that he represent our stock interest on the board and keep in contact with us regarding the situation which he has in mind.

Mr. LEVIS. More than the majority of the shareholders of Owens have expressed that same desire to me, and I don't think I am their representative.

Mr. Cox. I want to be sure I understand that, Mr. Levis. You don't mean that Mr. William Mandeville was the representative of the Owens Co. on the Thatcher board?

Mr. LEVIS. No, sir; the Owens Co. had no interest in it.

Mr. Cox. So far as he represented anyone, it was just a friendly interest on your part; is that correct?

Mr. LEVIS. Yes, sir. He could have been put on without that condition, and we couldn't have him put on. That is a letter to my uncle, who has been a great pal of mine for a great many years.

Mr. Cox. I want you to explain what the situation is. Did he keep in contact with you regarding the situation?

Mr. LEVIS. He wrote me from time to time giving me facts.

Mr. Cox. Is Thatcher Manufacturing Co. a competitor of yours at all?

Mr. LEVIS. In milk bottles and in general lines through Olean; yes.

Mr. Cox. You sell milk bottles in the same market; in the same general territory?

Mr. LEVIS. Yes, sir; we sell to a good many of the same customers.

Mr. Cox. Whatever the relationship was between you and Mr. Mandeville—and I will attempt to permit you to describe it—do you think that relationship had any effect upon the competitive practices between the two companies?

Mr. LEVIS. I know it didn't.

Mr. Cox. You think it made no difference?

Mr. LEVIS. No.

Mr. Cox. You still competed just as hard as you would have if he hadn't been on the board?

Mr. LEVIS. Yes.

Mr. Cox. When he kept in contact with you regarding a situation, did that contact ever involve reporting as to practices and policies with respect to sale of containers?

Mr. LEVIS. It didn't influence it, sir. I mean my relationship with Mr. Mandeville would have been just as pleasant had I not been a shareholder, as being one.

Mr. Cox. You and everyone in the glass business, manufacturing glass containers, are rather friendly, is that it?

Mr. LEVIS. They have always been nice to me.

Mr. Cox. You have all grown up together, haven't you?

Mr. LEVIS. I don't know hardly anyone in the industry whom I haven't known of for at least three generations.

Mr. Cox. Could you tell us now what directorships you hold in other companies besides Owens-Illinois?

Mr. LEVIS. I am a director of National Distillers and of the W. & A. Gilbey & Co., Ltd., which is the Gilbey American company; of the Weco Products Co. which manufactures and sells Dr. West tooth brushes, powder puffs, handkerchiefs and items of that kind; the Kimble Glass Company; the Owens-Illinois Co.; the Owens Staple-Tied Brush Co.

Mr. Cox. Were you ever a director of Hazel-Atlas?

Mr. LEVIS. Yes.

Mr. Cox. When did you resign?

Mr. LEVIS. It must have been in the spring of 1934. When I filled out this paper, sir, it shows that I was a director in '33 and was not a director in '36. As near as I can determine from asking the Hazel people, I must have been on about a year, from the fall of 1933 until the fall of 1934.

Mr. Cox. If I should suggest to you it was about sometime in the spring of 1935 that you resigned, would that refresh your recollection?

Mr. LEVIS. I wasn't on in '36 and I was on in '33 when I prepared this schedule.

Mr. Cox. Of course, Hazel-Atlas is a competitor of yours, isn't it?

Mr. LEVIS. Oh, Owens, not mine.

Mr. Cox. Can you tell us why you resigned from the board of Hazel-Atlas? Was there any particular set of circumstances?

Mr. LEVIS. I don't know. I went on the board because the Illinois Glass Co. made a large investment in the company and I thought I could contribute something in help and I figured that I had contributed that and I resigned.

Mr. Cox. Does the Owens-Illinois Co. or the Levis group, either one, now have a representative on the board of Hazel-Atlas?

Mr. LEVIS. No; only about insofar as William Mandeville might figure that he represents our interests. I have always voted the Illinois interest for Mr. Quay.

Mr. Cox. I am going to hand you a letter¹ now, dated April 1, 1935, another letter which you wrote to your uncle, and I call your attention to the last paragraph in that letter and ask you if it refreshes your recollection.

Mr. LEVIS. It does. I didn't recall it until I saw this.

¹ Subsequently introduced as "Exhibit No. 126," infra, p. 482.

Mr. Cox. In the last paragraph of this letter you say [reading from "Exhibit No. 126"]:

Because of the recent publicity given Owens-Illinois and our investment in Hazel-Atlas in a letter read into the Congressional Record of March 8 by Mr. Borah, I advised Mr. McNash that it would probably be desirable for me to resign as a member of their board at either their April meeting or their July meeting, and we discussed the advisability of having Mr. George Quay, secretary of the company, elected in my place, with the understanding that he would be representing us and that I would receive through him the same type of information I now receive as a director. I will see you in the meantime and we will have a chance to discuss just what should be done in this connection.

Would it be correct for me to suggest, Mr. Levis, that Mr. Quay, after you resigned, then went on the board as a representative of the Owens-Illinois Co. or the Levis group?

Mr. LEVIS. No, sir; he was elected to the board by the other directors, and then at a subsequent shareholders' meeting was elected by them. My proxy for the shares we had were sent to Mr. Quay. He either had the right to use it or not. That was optional with him.

Mr. Cox. You don't regard him as representing your interests on the board?

Mr. LEVIS. No more than I think I represent the Libbey estate interests, and you think I am all right.

Mr. Cox. You suggest that this choice of language in the letter is perhaps a little unfortunate, Mr. Levis. You didn't really mean that.

Mr. LEVIS. I didn't realize then that my letters I wrote to my uncle were not my uncle's and my private property.

Mr. Cox. Well, now, I will ask you this question, which is a similar question to the one I asked you about Thatcher a moment ago. Do you think whatever the relationship is between you or your company, or the Levis group, and Mr. Quay, that that relationship has affected in any way the competitive practices which the two companies have followed?

Mr. LEVIS. No, sir.

Mr. Cox. You think that they have competed just as if that relationship didn't exist?

Mr. LEVIS. Mr. McNash wouldn't give me credit on that kind of a basis.

Mr. Cox. I would like to have this letter marked and admitted.

(The letter referred to was marked "Exhibit No. 126" and is included in the appendix on p. 780.)

Senator KING. By that you mean there has been competition between the two companies?

Mr. LEVIS. Always.

The CHAIRMAN. Without objection, this letter may be marked and admitted as an exhibit.

Mr. LEVIS. Do you mean "without objection" that I don't object to its being admitted?

The CHAIRMAN. I mean on the part of the members of the committee; do you wish to offer an objection?

Mr. LEVIS. I do object to its being admitted. It is a personal letter to my uncle and isn't a business document of any kind.

The CHAIRMAN. You just testified with respect to it.

Mr. LEVIS. That I wrote it; yes.

The CHAIRMAN. You acknowledged it.

Mr. LEVIS. Yes.

The CHAIRMAN. And it was read into the record at that time.

Mr. LEVIS. You can treat it as you want to, sir; but I don't like to see it admitted. I don't think it has anything to do with the Temporary National Economic Committee.

Mr. Cox. Perhaps, Mr. Levis—I want you to understand what we are trying to do here, at least what the Department is trying to do, so you won't think we are taking unfair advantage of you. We went into this and your stockholdings in other glass companies and your directorships in other glass companies in relation to this patent problem merely because it has been our experience in enforcing the antitrust laws that one of the most difficult and at the same time nebulous problems we have is the effect on competitive conditions of that kind of interlocking relationship. Now, I have no desire, I am sure you don't, to argue out this afternoon the implications of those interlocking relationships, but we want to put this letter in the record, and the other material in the record, with respect to that kind of a situation so that the committee and the Department, for the purpose of whatever conclusions either the Department or the committee wishes to draw, will be in a position to see what the situation is in the industry with respect to those relationships. I want to make that perfectly clear to the witness.

The CHAIRMAN. I think that is clear to the witness. It certainly is to the committee.

Mr. LEVIS. Yes. My only theory is that he has something over 8,000 of my letters, and this one is quite remote and not to the point, and many of the other ones which are to the point that would be helpful would never occur.

Mr. Cox. I will make an offer to you. If you will select some of those you would like to have me put in, I will, without giving you a blanket guarantee, seriously consider putting them in for you.

I would like to ask you one or two more questions about this, Mr. Levis, because I think it has some importance. Why did you feel that that criticism was of sufficient force that you should withdraw from the board of Hazel-Atlas? Let me start with this question. You, I assume, were perfectly assured in your own mind when you were on the board that that relationship didn't violate the anti-trust laws and had no effect on competitive practices. Wouldn't that be an accurate statement?

Mr. LEVIS. I felt that way or I wouldn't have gone on.

Mr. Cox. Then why did you feel in view of the criticism that you should withdraw?

Mr. LEVIS. Because I couldn't find out who wrote the Senator. I had every member of the glass-container industry sign a petition voluntarily at a meeting, saying that they didn't write it and they weren't in sympathy with what was said, and at the same time we were members of the Code Authority under the N. R. A. Code. We resigned from that and from officership of the association because we thought that if anonymous letters were read into the record and no one could find out who wrote them, that we had better pull into our shell.

Mr. Cox. You felt perhaps that your company was frequently subject to that kind of criticism?

Mr. LEVIS. Yes, we were a publicly owned company, and I had committed some act which met with some disrepute which I didn't presume was entitled to that criticism.

Mr. COX. I think that clears up what I wanted to ask you about. I want to ask you some questions now about the contract between your company and the Hartford-Empire Co.—I say your company; I mean the Owens-Illinois Co.—that was made in 1924. You know the contract I am speaking of, I assume.

Mr. LEVIS. No; I know of it but I wasn't in the company when the contract was made.

Mr. COX. Were you, as an official of the Illinois Glass Co., at all familiar with the negotiations which preceded that contract?

Mr. LEVIS. Yes; we had presumed that we had rights under Hartford's patents, if acquired by Owens, and we were also a licensee of Hartford and in exchange for revision of our Hartford license we waived any rights that we had and became licensees of both companies.

Mr. COX. Can you recollect now, Mr. Levis, what the attitude of your company was at that time—the Illinois Glass Co. I am speaking of now—with respect to this proposed contract between Hartford and the Owens Bottle Co.?

Mr. LEVIS. I don't know that I could. If you have anything that would refresh my recollection, I might.

Mr. COX. I will read something to you which was not a statement which you made but a statement which was made by Mr. Ashcraft who, I understand, was at that time representing the Illinois Glass Co., is that right?

Mr. LEVIS. He was the counsel and a director.

Mr. COX. I will now read to you a statement contained in a letter written by Mr. V. M. Dorsey to Mr. Alexander D. Falck, at Corning Glass Works, dated November 5, 1921, which purports to report something that Mr. Ashcraft said, and I just ask you whether it refreshes your recollection. This statement is:

At a recent conference with Owens, Mr. Ashcraft of the Illinois Co., who is a licensee under the Owens Co. for certain rights, and under the Hartford Co. for other rights, vigorously put up to Owens the necessity of closing out these pirates, and that this could probably only and certainly be best done by a cooperation with the Hartford-Fairmont Co., the appeal being made to the Owens Co. in the capacity of manufacturers of glassware and as manufacturers of machines.

I think I started to read the quotation a little too early in the paragraph. I am going to read the first sentence in the paragraph to you now, and then I will give it to you to look at. The first sentence reads:

The Illinois Co., as manufacturers of glassware, are disturbed at the market conditions created by the fact that a number of irresponsible manufacturers have installed the pirate machine, namely, Howard, Miller, etc.

Then the paragraph proceeds as I previously read it. Will you look at that?

Mr. LEVIS. I was operating the factory in Alton in 1921.

Mr. COX. It doesn't refresh your recollection?

Mr. LEVIS. It wasn't until 1924 that I had anything to do with the patent situation. Mr. Ashcraft handled it prior to that time, with one of my uncles who since died.

Mr. Cox. Did you prior to that time have anything to do with competitive conditions in the industry?

Mr. LEVIS. Only to make better bottles and more of them.

Mr. Cox. You didn't have anything to do with the marketing end of it?

Mr. LEVIS. No, sir; I was an operating man.

Mr. Cox. You were engaged just in manufacturing containers?

Mr. LEVIS. That's right.

Mr. Cox. And this doesn't refresh your recollection at all as to the circumstances?

Mr. LEVIS. I might say by way of passing that the Illinois Co.'s policy always was to take a license under any patent that anybody thought they had, on the theory that it was cheaper to do that than it was to spend the time necessary to fool with the patent situation. We always pride ourselves that we had never paid a patent lawyer a dollar in the 70 years of existence. We paid the fee as our contribution to the fellow who worked on that end of it. We made products and sold them. We weren't interested in patents. That was my bringing up.

Mr. Cox. So you were engaged in manufacturing at that time under licenses which you took from other people?

Mr. LEVIS. It didn't make any difference who it was, if he said he had one we didn't even read it. We just signed it and paid it.

Mr. Cox. Do you recall whether in the light of what I read to you your company was ever disturbed by the fact that while it was paying under these licenses which they sometimes didn't even read, there were other manufacturers in the field who were using other machinery and not paying any other royalties?

Mr. LEVIS. We always complained about that, like we did about local taxes and anything else we didn't like.

Mr. Cox. You didn't like that kind of competition?

Mr. LEVIS. No.

Mr. Cox. In other words, if you were going to pay royalties, you wanted everybody else to pay royalties?

Mr. LEVIS. Or else tell us the patents weren't any good and quit talking about it.

Mr. Cox. But you wanted to be able to compete with those people on an even basis?

Mr. LEVIS. Yes, sir; except those who licensed like Owens, who spent money to develop.

Mr. Cox. But so far as other manufacturers were concerned, who weren't development concerns, you didn't want them manufacturing and selling bottles and not paying a royalty fee for the machinery while you were doing that?

Mr. LEVIS. More or less the other way around. We didn't want Hartford to collect a fee from us and not collect it from someone else if their patent was any good.

Mr. Cox. And of course to these pirate feeders, the pirate machines referred to in the letter, they were machines which people were using without the permission of Hartford Empire or of Owens.

Mr. LEVIS. I think Hartford had a patent structure they were trying to develop there. There was a lot of development in the art and it took a lot of litigation in the Patent Office to perfect it. We wanted

that hurried. We either stopped paying and everybody did or we paid and everybody else did.

Mr. Cox. You wanted it hurried so you wouldn't have to continue to compete with people manufacturing on what those people called the pirate machine?

Mr. LEVIS. I don't think that was the point. The point was, we didn't want to pay because the patent was good, and have another man not pay if it was good. We didn't care what the other fellow did, because when we took the license under Owens and Hartford we knew that they were more economical devices than the pirate devices, or else we would have taken a pirate device. We had the option of doing either, and we sought to take what we thought was best, and theirs was in our opinion better.

Mr. Cox. I want to be sure I understand you about that. Your feeling was rather a feeling that in fair play and equity you should be treated the same as anybody else by Hartford-Empire, rather than a feeling that the payment of royalties by you, when you were competing with someone who didn't pay royalties, subjected you to a competitive disadvantage?

Mr. LEVIS. I don't think the competitive disadvantage was there.

Mr. Cox. You don't think that had any part in the picture at all?

Mr. LEVIS. The other device was sufficiently inefficient that we always believed you could pay the royalty and have the efficient device and still have lower costs than if you used the pirate device.

Mr. Cox. So you weren't objecting to the pirate device?

Mr. LEVIS. We were interested in manufacturing under the patent.

Mr. Cox. That has been the attitude not only of the Illinois Glass Co. but also of Owens-Illinois?

Mr. LEVIS. I inherited a situation when I went into Owens-Illinois, but my general thinking on it hasn't been very different.

Mr. Cox. Do you feel that you are sufficiently familiar with the general provisions of that '24 contract so that you can discuss them in a general way? It was in existence when you came in Owens-Illinois in '29, was it not?

Mr. LEVIS. I am not familiar with it. I would much prefer that Mr. Williams or Mr. Belknap talk on it, because they had all to do with it.

Mr. Cox. There are two or three questions about the policy that I want to ask you in the light of the provisions of that agreement, and I wonder if you know enough about the provisions of the agreement so that I can ask the questions. I will try with some questions and if you don't know you must tell me, and I will try with someone else.

Under that agreement, Owens and certain subsidiaries gave to Hartford-Empire an exclusive, divisible, assignable license under patent rights for feeding glass which didn't relate to the suction method. Would you agree with that?

Mr. LEVIS. I couldn't give you the theory of that accurately, Mr. Cox. There were some situations in there. All I know is that when I came into the picture in '29 there was so much time consumed in conferring on these kinds of things and so little time consumed in really running the business that I did, over a period of 4 or 5 years, the best I could to get shed of all this patent stuff, to get down to making bottles and selling them.

Mr. Cox. You found if you would, you could spend all your time on it.

Mr. LEVIS. And that, after having Owens lose money.

We took in a lot of royalty; a lot of it came from themselves, a lot of it they paid out, and when they got all through our schedule showed we took in \$12,000,000 from outsiders in 18 years and paid out \$5,000,000 in 17 years, and we had about \$7,000,000 left, and our development expense in that same period was \$7,400,000, so we were out \$400,000 for fooling with it. I couldn't see that there was anything in that and when we stopped it in '35 and sold out our whole interest—true, the prohibition amendment had something to do with our success—we did better than we ever did.

Mr. Cox. You made more money after that contract was terminated?

Mr. LEVIS. Yes; we knew how to do that. We didn't know how to do patent things.

Mr. Cox. You wouldn't suggest that the net result of that contract which Hartford-Empire made in 1924 was that your company lost money, would you

Mr. LEVIS. Well—

Mr. Cox (interposing). I think we are talking about different things. You are talking about the whole of your patent activities. I am talking about the contract, considered apart from the rest of your patent activities.

Mr. LEVIS. I don't believe I have compiled that figure, but in 1931 I recall the first interest I had in the matter was to address a letter to Hartford waiving any right that Owens might have had to have restricted their licensees, which I had been informed had never been exercised; and in 1932 in a desire to get out of this situation and to clean up all that was behind it, we entered into an amendment agreement in which we gave up a sixth of the income from any patents that might have related to the '24 agreement, and as quickly after that as it could be arranged, which was in 1935, we sold all of our interest in the situation and we tried to carry our policy which, despite what the memorandas we might have written ourselves and the discussions we might have had, we felt that a patent is not a grant of right to use the thing; it is only a grant to exclude other people from using the same thing. And we have today 536 patents just so that we won't be excluded from doing something that somebody else has a patent on.

Mr. Cox. That is very interesting, Mr. Levis. In other words, as far as you are concerned, the only significance of the patent is it is a thing someone else may get and prevent you from doing something you may wish to do in connection with your manufacture.

Mr. LEVIS. If we want to go in and build suction machines and put any kind of gadget on them, we want to do it without reading a pile of patent papers to find out whether or not we can do it.

Mr. Cox. Would it be accurate to say you are not interested in keeping others from using them; you are just interested in using them in your own manufacture of glass?

Mr. LEVIS. That is an accurate statement of how I feel. I don't know what I might have said as trading talk on it.

Mr. Cox. I was just trying to develop the attitude you expressed a moment ago.

Mr. Chairman, I am about to go into this '24 contract. It is a matter which will probably take a half an hour or so. I am prepared to go along as long as the committee wishes, but if you wish to arise at the usual time this would be a convenient break.

The CHAIRMAN. The members of the committee have a few other duties to perform; and if there is no objection on the part of any member of the committee, if no other questions are to be asked at the moment, we will recess until tomorrow morning at 10:30.

(Whereupon, at 4 p. m., a recess was taken until Wednesday, December 14, 1938, at 10:30 a. m.)

INVESTIGATION OF CONCENTRATION OF ECONOMIC POWER

WEDNESDAY, DECEMBER 14, 1938

UNITED STATES SENATE,
TEMPORARY NATIONAL ECONOMIC COMMITTEE,
Washington, D. C.

The committee met at 10:45 a. m., pursuant to adjournment on Tuesday, December 13, 1938, in the Caucus Room, Senate Office Building, Senator Joseph C. O'Mahoney, presiding.

Present: Senators O'Mahoney (chairman), Borah, and King; Messrs. Henderson, Arnold, Patterson, Oliphant, Berge, and Thorp.

Present also: Department of Justice staff for Temporary National Economic Committee study—counsel, H. B. Cox (Special Assistant to the Attorney General); Joseph Borkin, Ernest Meyers, Charles L. Terrel, Benedict Cottone, David Clarke, George Dession, Fowler Hamilton, H. C. Engelbrecht, Victor H. Kramer, J. M. Henderson, Monroe Karasik, Irving Glickfeld, Hyman Ritchin, Norman Bursler, and Seymour Lewis; also chief counsel for Federal Trade Commission Temporary National Economic Committee study, George W. Williams.

The CHAIRMAN. The committee will please come to order.

Mr. Cox, are you ready to proceed? Is Mr. Levis to be on the stand again this morning?

Mr. Cox. Yes; Mr. Levis will be on the stand.

The CHAIRMAN. Have you brought an additional witness?

Mr. Cox. This is Mr. Williams, counsel for the company. I think we might have him sworn; he may not testify.

The CHAIRMAN. Mr. Williams, do you solemnly swear that the evidence you are about to give in this proceeding will be the truth, the whole truth, and nothing but the truth, so help you God?

Mr. WILLIAMS. I do.

Mr. Cox. Just give the reporter your name and address.

Mr. WILLIAMS. Lloyd T. Williams, 2025 Parkwood Avenue, Toledo, Ohio.

Mr. Cox. You are counsel for the Owens-Illinois?

Mr. WILLIAMS. Counsel for Owens-Illinois Glass Co.

TESTIMONY OF WILLIAM E. LEVIS, PRESIDENT, OWENS-ILLINOIS GLASS CO., TOLEDO, OHIO—Resumed

Mr. Cox. Mr. Levis, there are one or two loose ends in yesterday's examination that I would like to go over before we go ahead. Yesterday when I was asking you about your directorships held in other companies, I neglected to ask you whether you were ever a director of the Lynch Co.

Mr. LEVIS. No, sir.

Mr. Cox. You never were a director?

Mr. LEVIS. No, sir.

Mr. Cox. I also think it might be useful if you would tell me whether, in speaking of the group of persons we described yesterday as the Levis group, you included Mr. Boeschstein.

Mr. LEVIS. I would have included him.

Mr. Cox. Yesterday you told us you were a director of the National Distillers and of the Gilbey Co. Do you recall that?

Mr. LEVIS. Yes, sir.

Mr. Cox. Both of those companies use bottles in their business?

Mr. LEVIS. Yes, sir.

Mr. Cox. Do they buy bottles from Owens-Illinois?

Mr. LEVIS. Yes, sir.

Mr. Cox. I think I also neglected to ask you what percentage of the total outstanding stock of Hazel-Atlas is owned by what we describe as the Levis group. Can you give me a figure on that?

Mr. LEVIS. The Illinois Glass Co. owned, I think, a maximum of 22,000 shares. I may be wrong in that. It may have gone as high as 25,000 but for the longest period of time the holding was 20,000 shares, and that was the amount we distributed in liquidation.

Mr. Cox. In the case of the Lynch Corporation, will you tell us how many shares in that the Levis group held?

Mr. LEVIS. There was distributed in kind at the time of liquidation 4,500 shares.

Mr. Cox. I have a figure here which we obtained from your company of about 6,000. I wonder if we could some time work out that discrepancy. That is a figure as of today, based on the holdings of members of the Levis group.

Mr. LEVIS. That probably is so. The Illinois Glass Co. was a stockholder of record of 4,500 shares, and I own some shares personally, which, together, maybe, with the holding, might be 6,000 shares.

Mr. Cox. I am willing to check that.

Mr. LEVIS. I am willing that it stand as 6,000.

Mr. Cox. The exact figure I have is 6,644 shares.

Mr. LEVIS. That is probably correct.

Mr. Cox. Mr. Levis, I'd like to ask you some questions about the testimony which you gave me in respect to the company's attitude toward taking licenses on patents. As I understood, your testimony yesterday was that the attitude, or your own attitude and that of the Illinois Glass Co., was that all licensees of Hartford-Empire should be treated in the same way. Is that correct?

Mr. LEVIS. Would you make that a little clearer, Mr. Cox?

Mr. Cox. Well, I will put the question this way: It was your attitude and the attitude of the Illinois Glass Co. that no licensee of Hartford-Empire should receive preferential treatment over another licensee.

Mr. LEVIS. We weren't concerned with anybody else's business, Mr. Cox. As far as we were concerned, we had always made bottles of every description and we weren't going to sit back and be throttled by any licensing policy on the part of either Owens or Hartford. We went out until we got enough devices licensed to make everything that we had always made. What the other fellow did, that was his business.

Mr. Cox. You then were not interested in whether you got the same treatment from Hartford-Empire as a licensee that the other licensees got?

Mr. LEVIS. No; we had a favored nation clause, that is, no one could have anything more favorable than we could have.

Mr. COX. And that was your attitude on that question?

Mr. LEVIS. It was the attitude on that or even the purchase of supplies.

Mr. COX. Was that the attitude of the Owens-Illinois Co. after you became connected with that and acquired the assets of the Illinois Glass Co.?

Mr. LEVIS. Well, as I said yesterday, to restate, I inherited a situation in Owens-Illinois which I didn't know very much about.

Mr. COX. The thing you speak of inheriting, I presume, is the 1924 contract.¹

Mr. LEVIS. Well, no; a patent-licensing policy, the development organization and legal powers and applications, and things of that kind which we didn't know anything about.

Mr. COX. You didn't mean the 1924 contract?

Mr. LEVIS. The 1924 contract I didn't know of, other than it was in existence. I had never read it. That is when I went into Owens-Illinois.

Mr. COX. You feel today, I suppose, that your company should get the same treatment from Hartford-Empire that any other licensee gets; is that correct?

Mr. LEVIS. Yes.

Mr. COX. You have been successful, you think, in getting that kind of equitable treatment, Mr. Levis?

Mr. LEVIS. Yes, sir.

Mr. COX. Now I want to develop very briefly some of the provisions of that 1924 agreement; in case you feel you can't answer the question, perhaps Mr. Williams can. I am going to put the agreement in the record ultimately,² but I would like to develop briefly the character of some of the provisions. Do you wish to have a copy of the contract before you?

Mr. WILLIAMS.³ I have a copy here, Mr. Cox.

Senator KING. Which contract is this?

Mr. COX. This is a cross-licensing contract made in 1924 between Owens-Illinois and Hartford-Empire. Under that contract it would be accurate to say that the two companies exchanged licenses, Mr. Williams?

Mr. WILLIAMS. Yes; each granted to the other a license under the patents that they then had, or would acquire within the time stated, limited, however, to feeders and feeder-fed forming machines.

Mr. COX. The suction machine was excluded?

Mr. WILLIAMS. That is right.

Mr. COX. Under that contract the Owens Co. was to pay certain royalties to the Hartford Co.; is that correct?

Mr. WILLIAMS. They had a most-favored-nation clause that they got as low royalties or as good royalties as anybody got, with one or two exceptions.

Mr. COX. One of those exceptions was the fact that they had the use of 40 free units of machinery, did they not, or not to exceed 40 free units of machinery?

¹ Entered later as "Exhibit No. 135," see *infra*, p. 534.

² *Ibid.*

³ Lloyd T. Williams, general counsel, Owens-Illinois Glass Co.

Mr. WILLIAMS. Yes; although by the answer I meant with respect to certain other concerns that might have lower rates.

Mr. COX. I see, I beg your pardon, but that was an exception, at least it was a limit, a qualification of the royalties I speak of, the 40 free units.

Mr. WILLIAMS. Yes.

Mr. COX. That was in section 5 of the contract. Is that correct?

Mr. WILLIAMS. Yes.

Mr. COX. And under the contract Hartford-Empire was to make certain payments to Owens. Is that correct?

Mr. WILLIAMS. Yes.

Mr. COX. And would it be a correct summary of one of the provisions as to those payments to say that Owens was to receive one-half of Hartford's divisible income from licensed inventions, as divisible income was defined in the agreement?

Mr. WILLIAMS. Yes.

Mr. COX. And divisible income was defined in the agreement as including gross royalties, licensing fees in excess of cost, profits on parts, damages collected in infringement suits, less the \$600,000? That is in section 1 if you would like to look at it, I think page 7 of that contract. I hope you have followed this, Mr. Levis, because I want to ask you some questions about it.

Mr. WILLIAMS. Yes; there were five items. I think you mentioned the five, that is, the income from licensed inventions.

There was the income derived from royalties; license fees in excess of cost of the manufacturing of licensed machines; profits on manufacturing, lease, or sale of machines or parts; settlement for damages and profits arising out of infringements of licensed inventions, and other gross revenues with exceptions as provided.

Mr. COX. That same contract provided in section 1 in certain circumstances for the joint purchase of patent rights owned by others; is that correct?

Mr. WILLIAMS. No; not in section 1, I think.

Mr. COX. Can you find that, Mr. Williams?

Mr. WILLIAMS. It is not in section 1.

Mr. COX. I think section 21, I beg your pardon.

Mr. WILLIAMS. I think that is correct; yes.

Mr. COX. And in section 8 of the contract there was a provision that each party should vigorously prosecute infringements of patents owned or controlled by it, at its own expense.

Mr. WILLIAMS. Yes.

Mr. COX. And in section 8 of the contract there was a provision that if the parties couldn't agree as to the suits which were to be brought, that disagreement was to be arbitrated. Is that correct?

Mr. WILLIAMS. Yes.

Mr. COX. I wish you would look at section 22 of the contract, now, Mr. Williams, and tell me if that section provided that Hartford could not license anyone under the inventions which were covered in the cross-licensing agreement by Owens, without Owens' consent, except to existing licensees of Hartford for machines already installed or for additional machines, and to be used in the same fields covered by Hartford's existing licenses, or to any legitimate manufacturer who was defined as a glass manufacturer of good commercial and financial standing, who was not a commercial user of his own product, and the

license was to be in his case for the same kind of ware which he made 1 year previous to the date of the contract. Is that an accurate paraphrase of those provisions?

Mr. WILLIAMS. Yes; except that in the first class which you mentioned, not only the lines of ware or fields of ware covered by existing licenses but also that might be covered by outstanding contracts. That limitation was taken out of the contract on February 2, 1931.¹

Mr. Cox. I was going to ask you about that. Maybe we might run through very briefly some of the subsequent changes in that contract. I will suggest them to you and you tell me whether they are correct in a general way.

In 1932 the Hartford-Owens license was changed from an exclusive to a nonexclusive license. Is that correct?

Mr. WILLIAMS. Yes; among other changes.

Mr. Cox. Also certain other provisions were eliminated from the contract, such as the provision as to suits and the joint acquisition of rights.

Mr. WILLIAMS. An entirely new contract was drawn, and this 1924 contract was canceled.

Mr. Cox. And the new contract eliminated the provisions as to joint acquisition of outside rights and the provision as to litigation.

Mr. WILLIAMS. I think that is correct.

Mr. Cox. And, of course, in a separate contract in 1932 Owens got a license under certain suction patents of Hartford-Empire.² Is that correct?

Mr. WILLIAMS. That is right.

Mr. Cox. Is that an exclusive or nonexclusive license?

Mr. WILLIAMS. I think it was nonexclusive, but I can look at it and see.

Mr. Cox. That is my understanding. At the same time, the right to use 40 free units was surrendered?

Mr. WILLIAMS. Yes.

Mr. Cox. By the way, when you speak of a unit in that connection, it means one feeding and one forming machine?

Mr. WILLIAMS. It was so defined.

Mr. Cox. At the same time a change was made with respect to the divisible income so that Hartford-Empire was entitled to deduct \$850,000 from its gross figure before dividing with Owens-Illinois. Is that correct?

Mr. WILLIAMS. Correct.

Mr. Cox. And was any other change made at that time with respect—wasn't it at that time that the amount which Owens was to receive was cut from one-half to one-third?

Mr. WILLIAMS. Correct.

Mr. Cox. So that between 1924 and 1932 Owens got one-half of Hartford-Empire's divisible income, as to the agreement from 1932, and until 1935 it received one-third.

Mr. WILLIAMS. That is correct.

Mr. Cox. In 1935 another series of contracts was instituted as a result of which the right of Owens to receive any part of Hartford's divisible income was surrendered?

Mr. WILLIAMS. That is right.

¹ Entered later as "Exhibit No. 137," *infra*, p. 534.

² Entered later as "Exhibit No. 139," *infra*, p. 534.

Mr. Cox. And in consideration of the execution of those contracts and in consideration of that surrender of that right, and perhaps some other matters, Hartford paid Owens \$2,500,000, approximately?

Mr. WILLIAMS. Yes; payable in installments.

Mr. Cox. Payable in installments. Well, now, Mr. Levis, I'd like to ask you some questions about that contract. In the first place, I am going to show you a schedule of the payments made by Hartford to you under that contract between 1924 and 1937, and the payments made by you to Hartford. This was given to us by Mr. Martin. I ask you to identify those figures as being from your record and as being substantially correct.

Mr. LEVIS. Yes, sir.

Mr. Cox. This schedule which I am shortly going to offer for the record shows that between 1924 and 1937 you paid in royalties to Hartford-Empire \$3,962,921; you received in return under the '24 contract from Hartford \$4,815,093, so that there was a net return to you under that contract of about \$800,000. Is that correct?

Mr. LEVIS. Yes, sir.

Mr. Cox. May I have this marked in evidence?

The CHAIRMAN. It may be marked and entered in the record.

(The schedule referred to was marked "Exhibit No. 127" and is included in the appendix on p. 781.)

Mr. Cox. So at least on that contract, on that part of your patent licensing business, you did make some money, didn't you?

Mr. LEVIS. Not after the developments nor the legal expense that was involved. In fact, we never made any money, Mr. Cox, in our business, in the whole of the patent situation or in a division of it.

Mr. Cox. I will put it this way: The net result of the payments to and fro under that contract was that you ended the transaction on the credit side of the ledger so far as those payments are concerned.

Mr. LEVIS. Oh, yes; but I mean, we can't segregate each carload of bottles and determine whether that is profitable or not. It is our bottle business as a whole. Our patent business as a whole was unprofitable.

Mr. Cox. That is, taking the patent business in its entirety?

Mr. LEVIS. This is unprofitable if, accountingwise, you would charge against the income our development and legal expense.

Mr. Cox. Of course, this figure which I have read to you here doesn't include the 2½ million dollars you received in 1935.

Mr. LEVIS. That was for the sale of patents, sir.

Mr. Cox. Well, that wasn't a part of the consideration for that payment—

Mr. LEVIS (interposing). Wasn't royalty.

Mr. Cox. Wasn't that cancellation of your right to receive one-third of the divisible income of Hartford-Empire?

Mr. LEVIS. Well, it was for a settlement of everything from the selling of our patents and the cleaning up of a lot—

Mr. Cox (interposing). Including the surrender of your right to give up and receive.

Mr. LEVIS. But the 2½ million dollars—

Mr. Cox (interposing). You included that in determining whether or not you made a profit on your whole?

Mr. LEVIS. The whole patent business; yes.

Mr. COX. Of course, between 1924 and 1932 you also had the free use of up to 40 units of the Hartford-Empire machines?

Mr. LEVIS. So far as I know, it was never exercised.

Mr. COX. Will you refresh your recollection on that, Mr. Levis, because we have some documents from your file which would indicate that it was used.

Mr. LEVIS. Mr. Williams said that the Owens Co., before I came in, did have some free units.

Mr. COX. We have a document which would indicate that in 1929, just before you came in, they were using at least 15 of those units. Would you think that was substantially correct?

Mr. WILLIAMS. I couldn't tell you the number of them, Mr. Cox, but I simply know there were free units.

Mr. LEVIS. I might point out just this, which I think explains it: Under the provisions of the contracts, when Owens acquired the assets of Illinois, Illinois feeder licenses could have been surrendered and free licenses substituted for them up to 40, and we never felt that was the proper thing to do.

Mr. COX. Do you know if any of the free feeder units, to which you were entitled under the contract, were used by Owens-Illinois between 1929—¹

Mr. LEVIS (interposing). It was always my recollection that none were used; that we always paid our part of the rate.

Mr. COX. You think not one of those units—

Mr. LEVIS (interposing). I may be mistaken.

Mr. COX. Will you check on that, Mr. Levis?

Mr. LEVIS. I will check on that.

Mr. COX. You, on the other hand, Mr. Williams, are inclined to believe that at least up until 1929, with the 5-year interval there, some of those free units were used by the Owens Bottle Co.?

Mr. WILLIAMS. The Owens Bottle Co. did have free units. I can't tell you just the period or just the number, but they did have some free units.²

Mr. COX. They did use them to manufacture bottles?

Mr. WILLIAMS. Yes.

Mr. COX. Now, Mr. Levis, taking this contract in its entirety, let's consider it for a minute. Under that contract³—

Senator KING (interposing). Are you speaking of the 1924 or the later one?

Mr. COX. I am speaking of the contract from 1924, first, to 1932. Under that contract your company received one-half of the divisible income of Hartford-Empire and also the use, if it cared to take advantage of the opportunity, of these free units?

Mr. LEVIS. Yes, sir.

Mr. COX. Don't you think that provision in the contract gave the Owens Co. a certain competitive advantage in the manufacture and the sale of bottles?

Mr. LEVIS. It would only be an opinion, sir, because I had nothing to do with the negotiation, but my opinion always was that the

¹ Mr. Levis later stated that 15 feeders were used under the free provision of the 1924 contract. See, *infra*, p. 517.

² *Ibid.*

³ Entered later as "Exhibit No. 135," *infra*, p. 534.

Owens Co. had as valuable a feeder patent structure that was contributed to the Hartford Co.'s patent picture as Hartford then had, and that they were entitled to compensation for their contribution, and Mr. Williams might verify that.

Mr. WILLIAMS. That is right. When the contract was made in '24 Owens contributed patent rights by license that it had and which it claimed dominated the Hartford machine. Litigation had been started and they were in for a free-for-all fight when this settlement was made.

Mr. Cox. Will you give us the names of those patents, if you can?

Mr. WILLIAMS. The Bock patent, the Lott patent, and the Brookfield patent are the ones I recall, and there were many others listed in the schedules attached to the contract.

Mr. Cox. And it is true, is it not, when you spoke of litigation you referred to the suit the Owens Co. had started against certain users of the Hartford-Empire feeders?

Mr. WILLIAMS. Yes; against one, I think.

Mr. Cox. So one of the circumstances which led to the making of the 1924 contract, in your opinion, was the fact that the parties had patents which appeared to cover, at least each asserted that the patents covered machinery which accomplished the same result, and they were both threatened with litigation as a result of that situation.

Mr. WILLIAMS. Yes; and if the claims of each were sustained in any major part, the result would be that neither could make a substantial or efficient feeder and each would be blocked by the other.

Mr. Cox. Each would be blocked by the other?

Mr. WILLIAMS. That is correct.

Mr. Cox. And as far as those companies were concerned, there wouldn't be any patents on automatic feeders effective?

Mr. WILLIAMS. Well, there would still be patents that each would have, but the difficulty came with the infringement that arose out of the use of any specific mechanism that either would make.

Mr. Cox. The patent would be there, but it wouldn't be much good as a patent because there would be an effective right to sue for infringement?

Mr. WILLIAMS. Well, either party could have sued anyone who made a feeder that infringed his patent, so that the patents still had their value. The difficulty arose in the use of any mechanism that was covered in part or in whole by the patents of either

Mr. Cox. They might have been each suing each other?

Mr. WILLIAMS. Yes.

Mr. Cox. Rather than face that situation, they made the contract and provided for the cross licensing?

Mr. WILLIAMS. That's right.

Mr. Cox. Well now, Mr. Levis, taking this provision providing for the division of the income of the Hartford-Empire, wasn't the effect of that that the Owens Co. was getting a kind of rebate on all the royalties paid by other licensees of Hartford-Empire?

Mr. LEVIS. No; I don't think so, Mr. Cox. The Owens Co., back in 1904, developed a patent structure and they received royalties from many companies. They were in the royalty collecting and patent development game, just about like the Hartford people subsequently became.

Mr. Cox. You mean they gave up that part of the business?

Mr. LEVIS. So far as they could have owned it in the licensing of feeders to their existing licensees and others. In fact, I don't know accurately, but it is my recollection that the Graham A. W. machine was licensed to Coshocton in 1917, to Glenshaw in 1918, to Turner in 1918, by the Owens Co., and that they were a feeder fed machine, and they went on in the development of their art and—

Mr. Cox (interposing). Are those the last licenses in point of time?

Mr. LEVIS. No. The 1932 license to Hazel-Atlas in July, and the October 31, 1935, to Hazel-Atlas, of which you have copies—

Mr. Cox (interposing). But aside from Hazel-Atlas, the three you have named are the last licenses that have been issued.

Mr. LEVIS. Yes; that is our record.

Mr. Cox. Prior to that time most of your licenses had been issued before 1914 and 1915?

Mr. LEVIS. Yes.

Mr. Cox. Now, if I understood your answer a moment ago, it was in effect that the result of the 1924 contract really was that the Owens Co. gave up the business of licensing under its patents which might have provided some revenue for it, and turned that over to Hartford-Empire to manage for them, and they went on conducting their licensing in the suction field, extracting royalties from the Illinois Co., of which you were then president.

Mr. LEVIS. They carried on the business in the suction field, and the Hartford group carried it on in the feeder field and they got part of the income from that that they contributed to, and Hartford had contributed nothing to the suction field, therefore didn't participate.

Mr. Cox. As far as other business in patents is concerned, Owens' last business in the suction-licensing field was in 1915.

Mr. LEVIS. The last license was 1918.

Mr. Cox. Most of them had been granted before that, up to 1915. Now, isn't it a fact, Mr. Levis, that under the provisions of the division of income, every licensee who was paying royalty to Hartford-Empire was in effect paying part of that royalty to you, to your company? I am speaking of the Owens Bottle Co. and not the Owens-Illinois Co.

Mr. LEVIS. That is what actually happened, Mr. Cox, but as a matter of fact, as a bottle manufacturer I think but very few of them ever thought of it as royalty. It was their contribution to the development of the art, the furnishing of a service on the part of Hartford which kept patent things straight and development things straight, and they didn't have departments like Owens have, big machine shops and patent linguists and patent draftsmen and solicitors, and all those things. They bought that for a fee to Hartford, who gave them splendid service and put them in a position to become better competitors in the industry—because they acquired that service which made them better manufacturers.

Mr. Cox. Part of the fee they paid for that went to you, to your company?

Mr. LEVIS. No, sir; we contributed certain patents and development and legal expense to them and they collected in the form of royalties for us. We never thought of it as our putting up nothing and taking in something.

Mr. Cox. I am not suggesting that that was quite the situation, Mr. Levis. The point I wish to develop is this. Here were a large number of concerns engaged in manufacturing bottles, glass containers, they were licensees of the Hartford-Empire, and a great many of them, I suppose to a greater or less extent, were your competitors, were they not?

Mr. LEVIS. Yes, sir.

Mr. Cox. They were paying license fees, a royalty fee to Hartford-Empire, and a part of those royalty fees were being given to you under the provision of the division of income.

Mr. LEVIS. Yes; but Mr. Cox, I ran the Illinois Glass Co. from 1924 to 1929 and I not only paid Hartford royalties on patents, part of which they got, but paid royalties on patents, all of which they got, and never was unhappy about it.

Mr. Cox. I am glad you mentioned that, because I want to ask you about it. You were perfectly content with that situation, were you?

Mr. LEVIS. I stated so yesterday. We believed that we got more efficient devices and service in dealing with organizations of that type than if we had taken pirate devices.

Mr. Cox. And you think that from the competitive point of view, that that was a perfectly proper thing for your competitors to be paying royalties to Hartford and having those royalties divided or rebated to you?

Mr. LEVIS. You have got to clear up who "you" is in this.

Mr. Cox. I am not trying to fix you with personal responsibility.

Mr. LEVIS. I mean, Owens or Illinois.

Mr. Cox. I am talking about Owens. I want your judgment on the thing as a man who has been in the glass business for a good many years. You think competition is a good thing, don't you, in the glass business?

Mr. LEVIS. Yes, sir.

Mr. Cox. I just want you to tell us whether you think that is the sort of condition that is conducive to healthy competition, when one company, and a large company, Mr. Levis, is getting a rebate of this kind.

Mr. LEVIS. It is improper to term it a rebate.

Mr. Cox. I will withdraw that term. I will say a division of royalties of that kind.

Mr. LEVIS. If you want my personal opinion, Mr. Cox, as a man who has been in the glass business, I have never felt that the word "royalty" was a proper word. I always thought of our payment as a contribution to the development of the art, and that the people who collected that performed certain services for the manufacturer which he didn't have to perform himself. I always thought we got that service. We complained about it, but we complained about everything.

Mr. Cox. Now, taking that definition, what service was Owens-Illinois performing for these licensees of Hartford-Empire that in your opinion justified the payment to Owens of a part of the royalties which the licensees were paying to Hartford-Empire?

Mr. LEVIS. They were collecting in installments the purchase price of the patents that they put into the group.

Mr. Cox. Those are the gob-feed patents that Mr. Williams spoke of?

Mr. LEVIS. Yes. And, second, they were perfecting those, and any right that they developed in that connection flowed to Hartford as a part of the consideration for the payment.

Mr. Cox. Throughout this period—if you don't know, perhaps Mr. Williams can tell us whether the Owens Co. was doing development work on the gob-feed patent as distinguished from the suction.

Mr. LEVIS. Oh, yes; anything we do goes to Hartford, and he takes it and gives it to our competitor to use against us.

Mr. Cox. But, of course, so far as that situation existed between 1924 and 1935, when your competitor used the device, you in effect collected a royalty on it through this division of income.

Mr. LEVIS. We received a part of the divisible income.

Mr. Cox. Then would you say, Mr. Levis—and I want you to think very carefully about this—that it was never your policy or the policy of the Owens-Illinois Co., as long as you were connected with it, to receive better treatment from Hartford-Empire than other licensees in the field received?

Mr. LEVIS. Mr. Cox, that is a very broad question. If you limit it, I will try to answer it.

Mr. Cox. Well, I will put it this way: Was it your policy to turn the whole patent and licensing business over to Hartford-Empire for development and exploitation and to receive in return a preferential treatment so far as the payment of royalties was concerned?

Mr. LEVIS. Mr. Cox, as I explained yesterday, my bringing up in this thing was different from that. When I came into the Owens-Illinois Co. I knew very little about patent matters. They had a large investment in a licensing business. I was the president of the company and wanted to liquidate. I even sought to inaugurate a policy so far as their licensing business was concerned that we would pay no royalty to anyone, that everybody else would pay a royalty to someone, and we would get just as much of that as we could.

Now I found out, at least along in '33 and '34, that I was just swapping dollars and I was riding railroad trains and I wasn't making a dime, and as soon as I could convince the people who had grown up in the other field that my doctrine of this thing was right, we finally sold out and started on in our business; and as I said to you yesterday, we were more successful after we did it.

Mr. Cox. You found it didn't pay to try to make money out of the patent situation.

Mr. LEVIS. Even with the policy as I stated it, it didn't pay, because the time of our principals who had to devote their thinking to these interferences and litigation and how to keep from being excluded in fields was consumed away from the business features of our company.

Mr. Cox. Then if I understand you correctly, your purpose at one time was to create a situation where everyone else in the field would pay a royalty for the inventions which they were using, and that your company would not pay a royalty to avoid doing so?

Mr. LEVIS. No; I don't think that was ever my purpose, Mr. Cox. Just like I would like to sell certain items cheaper, but there are certain factors in connection with an investment that we owned that I felt we must liquidate profitably, that I tried even to create a policy.

and even if that policy had been 100 percent successful, then that division of our business would not have been profitable, and consequently, having tried it for 5 years without success, I sought the policy of abandonment.

Mr. COX. You did make a change in policy?

Mr. LEVIS. Yes, sir; changed my mind, and it wasn't much different after I changed it than when I started, because the Illinois Co. had been successful under the other policy.

Mr. COX. To the extent there was a change, it was a change from the policy which you say you inherited when you came into the Owens Co.

Mr. LEVIS. That is the way I think of it.

Mr. COX. I just want to get a precise definition of what that policy was that you inherited.

I am going to show you a document which purports to be a copy of a pencil memorandum, and I call your attention to the paragraph I have marked.

Mr. LEVIS. Before I look at it, I want to correct you to this extent: This isn't the policy; this is my idea of to what extent we might go to try to make this division of our business possible.

Mr. COX. What are you describing now?

Mr. LEVIS. A restatement of your question that you were handing me something.

Mr. COX. Are you describing what this is that I have given you now?

Mr. LEVIS. No; I was answering your question in giving it to me.

Mr. COX. You look at that, Mr. Levis, and see that paragraph that I have marked. It is the paragraph which begins, "Our negotiations with Hartford-Empire Co. and others," etc.

Senator KING. Are you referring to the policy after 1934 or under the 1924 contract?

Mr. COX. I have to find out from the witness first when this memorandum was prepared. That is the next question I am going to ask him. It is undated.

When was it prepared?

Mr. LEVIS. I don't know. I have no recollection of the memorandum. Some of your men went to Alton and took from my office personal files a lot of papers that my uncle had accumulated, evidently for sentimental reasons. I had no copy, and this was one of them, and when I saw your typed copy of what one of my men who has been with me for many years said is not in my writing, it doesn't differ, though, sir, from what my thinking was as a kid in 1929, starting out to liquidate this undesirable part of this business.

Mr. COX. You think this substantially describes your attitude?

Mr. LEVIS. It describes what I might have been thinking, but it doesn't describe what I think now.

Mr. COX. I understand that. What I am trying to find out now is what the precise policy was that you did change in '35, and this is the policy that you did change.

Mr. LEVIS. We never were able to carry that out.

Mr. COX. That is what you were trying to do?

Mr. LEVIS. No; that is what I believed it would be necessary to do to make that division of our business profitable.

Mr. Cox. I think perhaps we might read this so it will be clear what we are talking about. The paragraph reads:

Our negotiations with Hartford-Empire Co. and others, so far as our patent situation and royalty income is concerned, should be to attempt to secure a position whereby we pay no royalty on any item we produce and we attempt to force all others to pay royalty on every item they produce, we participating with anyone else in the royalties they receive.

I suppose "they" means Hartford-Empire.

That is the policy you thought you would have to adopt if you were going to make any money out of patents?

Mr. LEVIS. Yes. The early part of the memorandum tells of the policies I thought we would have to adopt if we were going to make money selling bottles.

Mr. Cox. That is the policy you gave up in 1935?

Mr. LEVIS. No; I gave it up right along. I can't state what date I started to think differently. I had a right to change my mind. This was a memorandum evidently prepared for me to talk over with my uncle, who was an old head in the business, and when I got through spending the evening with him I probably left it with him. I don't see any economic significance to it.

Mr. Cox. You have told us you changed the policy. I think I understand what the policy is today, so I am going to ask you about that in a moment; but I want to get a precise definition of some kind as to what the policy was you changed, and if this represents, at least in one form, the acme of that policy, or what you thought you might have to do to accomplish the result to which your prior policy was directed, I am content.

Mr. LEVIS. That is right.

Mr. Cox. How would you describe your policy on patents today, Mr. Levis, or since 1935? I am going to ask you some questions later on about licensing. Let's confine it now to the collection of royalties paid by others manufacturing bottles. Are you interested in collecting royalties from other persons who are engaged in manufacturing bottles and who are competing with you?

Mr. LEVIS. No, sir.

Mr. Cox. That has been your policy since 1935?

Mr. LEVIS. Yes, sir.

Mr. Cox. Do you collect any royalties today from anyone engaged in manufacturing bottles in competition with you?

Mr. LEVIS. We have a few small contracts, like the Dominion Glass Co., who really aren't in competition with us, and we have some small income from gadgets like decorating and items of that kind, but certainly we have no competitive advantages as a result of royalty income.

Mr. Cox. You don't get any royalties from any of the large companies manufacturing glass containers, such as Hazel-Atlas and Ball Bros.? I am speaking of the period of time since 1935.

Mr. LEVIS. Our royalties received in the years 1936 and 1937 amounted to \$2,690,000 in the year 1936, of which \$2,624,000 was paid by ourselves; \$12,752 by the Dominion Glass Co.; \$1,179 by the Thatcher Co.; \$614 from foreign sources. There are a number of other small items that don't relate to glass. Does that answer your question?

Mr. Cox. That answers the question.

When you say you paid them yourselves——

Mr. LEVIS (interpolating). It is simply bookkeeping. In other words, in determining our cost we like to have in, as an element of cost, royalties, even though we charge them to ourselves.

Mr. Cox. All right; I think that answers my question.

Now, Mr. Levis. I want to ask you some questions about section 22 under the 1924 contract,¹ which I think you said a moment ago was withdrawn in 1931; or Mr. Williams said that. Do you recall that was a provision which prevented Hartford from licensing people under your patents without your consent, except in the specific cases mentioned there, which in effect might be summarized by saying they could be given only to people who were in business or under license to Hartford at the time the contract was made? That section was taken out of the contract in '30 or '31, I think, after you came into the Owens-Illinois Co.

Mr. LEVIS. January 3, '31.

Mr. Cox. Tell us why that was taken out.

Mr. LEVIS. All I know is that when I came there I was advised that it never had been exercised and Mr. Williams asked to have it removed from the contract, and I thought if it wasn't an essential feature I was willing that that be done.

Mr. Cox. Was one of the reasons, Mr. Williams, why you thought it better be taken out because it raised some question under the anti-trust laws?

Mr. WILLIAMS. It was the one vulnerable spot, I thought, in the contract; or rather, the provision that would raise objections. I objected to putting it in, in the first place and was overruled.

Mr. Cox. When you took that provision out, did it make any difference in the nature of your relationships with Hartford-Empire at all?

Mr. LEVIS. No. So far as I was concerned, I was advised that it had never been used, and Mr. Williams, for some reason, didn't want it in, and I didn't see any reason why it should have been in anyway.

Mr. Cox. Isn't one reason why you took it out because you felt sure Hartford-Empire wasn't going to grant licenses recklessly or in disregard of your interests?

Mr. LEVIS. Oh, no.

Mr. Cox. I am going to read to you a paragraph of a memorandum which was sent to you by Mr. Carter, who, I understand, is your vice president in charge of your patent section in your legal department. Is that correct?

Mr. LEVIS. He was.

Mr. Cox. This memorandum is dated December 13, 1930.² It reads as follows [reading from "Exhibit No. 146"]:

The objection on our part to eliminating section 22 is the fear that Hartford, once freed of our veto, might be inclined to grant licenses recklessly and without regard to the state of the market or good of the industry. Believe that this fear is much exaggerated. We have been dealing with Hartford under our 1924 agreement for more than 6 years now and have never found any tendency on their part to act recklessly or in disregard of basic conditions. Believe we may safely conclude that their attitude in the future will not be different.

¹ Entered later as "Exhibit No. 135," p. 534.

² Subsequently entered as "Exhibit No. 146." See appendix, p. 789, at p. 791.

I ask you if that is not a statement of a reason for agreeing to the abolition of the section which is in substantial agreement with my question to you a moment ago.

Mr. LEVIS. Mr. Cox, when I got to Toledo in April about every 20 minutes I got six memoranda like that. I just couldn't read them. They didn't have anything to do with the business. You take my early '29 memoranda, all of which you have, and they don't differ at all in the theories I explained. Maybe there is some trade talk in some memorandum Mr. Carter did, but my way of handling this business hasn't been a darned bit different, and the way my early memoranda indicated I was raised. That memorandum had no effect on me. I was simply a young fellow in there, and they said, "Mr. Williams would like this paragraph out of the contract," and I said, "Well, have you ever used it?" They said, "No." I said, "It doesn't amount to anything, anyway, so take it out."

As to what Hartford would do, as to whether they would do something we asked them to or not, I don't think that ever worried us.

Mr. Cox. Weren't you interested in the persons to whom they granted licenses?

Mr. LEVIS. Yes. I think other bottle manufacturers were more interested in it than we were.

Mr. Cox. But you were interested in it to some extent?

Mr. LEVIS. Oh, yes; but we had the largest percentage of our production on our own royalty-free machines. At that time we had a participation for the patents we contributed to in the 1924 Hartford contract.

Mr. Cox. Isn't it a fact that even since the abolition of this provision in the contract you have talked to Hartford-Empire and consulted with them about the wisdom and propriety of granting licenses under their patents?

Mr. LEVIS. I may have, Mr. Cox. I complain and talk about things of that kind just like I would about some enactment of legislation I might not like, but as for ever believing that I could, other than through my own personal persuasion, get some fellow to do something because I had a contract with him to force him to do it, I didn't.

Mr. Cox. You did at least offer your advice or suggestions on that?

Mr. LEVIS. Oh, I offer that freely, sir, to everybody in the glass industry, and lots of them take it.

Mr. Cox. Have you ever suggested or advised Hartford that in your opinion they should be careful about granting licenses to people who want to go into the business of manufacturing bottles and containers?

Mr. LEVIS. I may have, sir, but I don't recall the incident.

Mr. Cox. I am thinking generally now. I have one instance that occurred in 1933 that I am going to ask you about in a moment, but I just want to ask you now if you had any general statement on that that you wanted to make.

Mr. LEVIS. I don't believe, Mr. Cox, that I feel at all that I have anything to do with that.

Mr. Cox. Now, Mr. Levis, I am going to read to you a letter¹

¹ Subsequently introduced as "Exhibit No. 128." See appendix, p. 781.

which you wrote January 13, 1933, to Mr. F. Goodwin Smith. It reads as follows [reading from "Exhibit No. 128"]:

Referring to Mr. Northend's letter of January 10 regarding the persistent letters he has received from Mr. E. C. Devlin, I am replying to you rather than to him because I feel that you should know that the old Northern Glass Co. plant never was operated successfully and that I do not think we should be at all concerned regarding their thoughts of resuming operation.

We are in splendid shape to take care of Milwaukee trade from our Streator, Ill., plant, and while I want to keep posted from time to time about people who inquire for licenses for the manufacture of beverage bottles, I think the position that you are taking—that there is at present considerable overproduction in the industry—should be maintained in replies to similar requests.

I ask you if you in fact wrote that letter to Mr. Smith.

Mr. LEVIS. Yes, sir.

Mr. Cox. That was a situation, was it not, where Mr. Devlin had been writing to Mr. Smith about getting a license and Mr. Northend had written to you about it?

Mr. LEVIS. He probably had, Mr. Cox. I can't remember that.

Mr. Cox. You don't remember anything about it?

Mr. LEVIS. It is just one of many things in 10 years' work.

Mr. Cox. The correspondence you had with Hartford involved a request that had been made to them for license for use in a glass-factory plant somewhere in the neighborhood of Milwaukee. Does that refresh your recollection at all?

Mr. LEVIS. No, sir. There may have been many such letters, and I may have answered them in that same way.

Mr. Cox. Was it your position at that time that you wanted to keep posted from time to time about people who inquired for licenses for the manufacture of beverage bottles?

Mr. LEVIS. Yes, sir.

Mr. Cox. Why did you want to be posted?

Mr. LEVIS. I wanted to be posted on everything.

Mr. Cox. Was that just curiosity, or did you have some specific purpose in mind that you wanted the information for?

Mr. LEVIS. I don't think I had any specific purpose, Mr. Cox.

Mr. Cox. If I should suggest to you that what you really wanted to know was who was asking Hartford for a license for that purpose, so you could discuss with Hartford whether the license should or should not be granted, would you repudiate that suggestion?

Mr. LEVIS. I wouldn't repudiate any suggestion, Mr. Cox. You have 8,000 pieces of my papers. I will try to help you in working any of those out, but I just can't remember each isolated letter that I wrote to Goodwin Smith. Show me the incident, and if I can refresh my memory I will tell you the truth.

Mr. Cox. I am sure you will, Mr. Levis. I am not asking you now about a particular incident. I am asking you about the general statement you make that you want to keep posted from time to time about people who inquire for licenses for the manufacture of beverage bottles. You said you wanted to keep posted about everything, and I still want to know whether you wanted to know about people who inquired as to beverage bottles merely out of curiosity or because you were interested in seeing that too many of them didn't go into business.

Mr. LEVIS. I had no way of controlling whether they went into business. I was interested in protecting my own business.

Mr. Cox. Of course you could talk to Mr. Goodwin Smith about it?

Mr. LEVIS. I could talk to anyone in the industry about it.

Mr. Cox. In your very persuasive manner, Mr. Levis?

Mr. LEVIS. Well—

Mr. Cox (interposing). Now I call your attention to this last sentence in the letter:

I think the position that you are taking—that there is at present considerable overproduction in the industry—should be maintained in replies to similar requests.

Was that your position at that time?

Mr. LEVIS. Yes; I think that was the position of all glass manufacturers at that time. I think that any licensee of the Hartford Co. would have told Mr. Smith that same thing.

Mr. Cox. It was a situation where it wasn't desirable to grant any more licenses?

Mr. LEVIS. The banks had just all been closed, and we were in the peak of the depression with a tremendous overproduction.

Mr. Cox. Is that your attitude today? Do you think there is overproduction today?

Mr. LEVIS. In the glass industry? Yes, sir.

Mr. Cox. And would you say that you think because of that overproduction licenses should not be granted by Hartford-Empire to people who apply for the right to go into business?

Mr. LEVIS. I have nothing to do with Hartford-Empire, sir, and I don't know what they would do. So far as I am concerned, I think that there are plenty of people in the business and there is an overproduction.

Mr. Cox. Would it be correct for me to say that if you had occasion to write a letter today to Mr. Smith like the letter you wrote in 1933, your advice to him would be the same?

Mr. LEVIS. My advice to him would be that I think there is an overproduction.

Mr. Cox. And that no more licenses should be granted?

Mr. LEVIS. I don't think I would add that now.

Mr. Cox. As a matter of fact, you have from time to time been interested in the use of patents as a device for stabilizing conditions in the industry, haven't you, Mr. Levis?

Mr. LEVIS. Yes, sir.

Mr. Cox. And, of course, the best way that can be done is through Hartford-Empire, since they are the license-granting organization in the real sense, aren't they?

Mr. LEVIS. We are, too, Mr. Cox.

Mr. Cox. You haven't granted any, though, since 1918.

Mr. LEVIS. Nobody has either the capital with which to buy one of our complicated machines or the organization capable of making it work.

Mr. Cox. That is very interesting. Are your machines very expensive to buy?

Mr. LEVIS. Expensive to build.

Mr. Cox. To build, I mean.

Mr. LEVIS. Yes.

Mr. Cox. Can you tell us about that? Why is that?

Mr. LEVIS. Because they are precision machines.

Mr. COX. Have to have special dies?

Mr. LEVIS. Yes. I think we paid \$65,000 for the last 10-arm machine.

Mr. COX. If a man wanted to go into business, to get a license from you and build a suction machine it would cost him about \$65,000 to build one machine?

Mr. LEVIS. It might cost him more than that to build the first one.

Mr. COX. Returning for a moment to the use of patents to stabilize the industry, you said you were interested in that from time to time. In that kind of stabilization do you include elimination of price cutting, stabilization of prices on any line of ware?

Representative SUMNERS. Mr. Cox, at some time would you develop the cost of installing an efficient unit to produce these glass bottles? I mean to establish a business, a small business, but a business sufficiently complete to produce the finished article that would require some place to melt the sand and whatever goes with it.

Mr. COX. I will do that through these witnesses if I can, so far as their particular kinds of machinery are concerned, and through other witnesses as to other kinds of machines.

Representative SUMNERS. I wouldn't want to take too much time, but it would be interesting.

Mr. COX. Perhaps Mr. Levis can tell us about that.

Mr. LEVIS. Very briefly, sir—we have always analyzed it—it costs about \$500,000 per furnace to go into the glass-container business; that is, the furnace that melts the glass, the forming devices for making the ware, and the annealing ovens, with their buildings and packing-house facilities. Another \$100,000 should be added to cover compressors and office facilities and machine shop, and about half a million dollars working capital, or \$400,000 to make a round number, requiring about a million dollars invested capital, which you would turn once in the production from that furnace, about a million dollars in sales. That wouldn't make any difference, sir, whether that had our suction machine on it, or, say, we put two suction machines to draw 100 tons, or whether we put six or seven Hartford machines on to draw that same tonnage.

The CHAIRMAN. It would make a big difference, however, Mr. Levis, whether or not you had to pay any actual royalty.

Mr. LEVIS. Yes, sir; except that you would be paying the royalty—well, it is like a suit of clothes in the expense account; if you have to go through the development and work out the applications and work out the interferences in the patents, you spend it that way, or you pay Hartford a fee for their service.

The CHAIRMAN. I was comparing this typical plant which you have just described with your plant, and considering the position that it would occupy as a competitor of your company. When you were giving your figures on royalty a few moments ago, I was struck by the fact that as a rule you recited that about 2½ million dollars will be charged against yourself as royalties, as an item of cost; in other words, you didn't actually pay that royalty.

Mr. LEVIS. We paid more than \$600,000 of it to Hartford.

The CHAIRMAN. Yes; but 2½ million, as I recall—

Mr. LEVIS (interposing). It is 5 percent of selling cost, roughly.

The CHAIRMAN. This is the point I am getting at. Whatever it was, 2 million or 2½ million, there was a substantial portion of

that royalty which actually never was paid to anybody. You charged it against yourself as an item of cost. Now I gather from an accounting procedure your purpose in doing that was to make certain that into the price of the article which you sold would go this element of royalties which your competitors were actually paying upon all their machines. Is that right?

Mr. LEVIS. Yes, sir; but if I might carry on briefly, we then credit that to a so-called holding division as income to that division, and then we charge that division for our experimental and development expense, and our patent and license expense, and our legal expense, and the holding division consumes that. In other words, we spent \$1,811,000 of that \$2,000,000 last year that we charged ourselves two million six for use in research and development alone.

The CHAIRMAN. I thought that you had practically shed yourself of that element.

Mr. LEVIS. Oh, not on the suction, sir. I tried to make it clear yesterday that we are always taking out patents on that.

The CHAIRMAN. So that of this two and a half million charged to yourself as royalties, but not actually paid as royalties, there were actually \$1,800,000 expended in research or similar activities. Is that correct?

Mr. LEVIS. Yes, sir. We then paid, of that that we received—

The CHAIRMAN (interposing). I am not interested in the exact figure, Mr. Levis. I was merely trying to determine whether or not that was an actual item of overhead, actually laid out or not.

Mr. LEVIS. No; we actually charged the bottle division of our parent company with royalty at 5 percent of their selling price, and if they owe Hartford something, the holding division, which we call it, pays Hartford the royalties, and it spends the rest of that money in research and development, patent and legal and general overhead.

The CHAIRMAN. If the actual amount were computed only, instead of just this arbitrary amount of 5 percent, would that be smaller?

Mr. LEVIS. No; it would be about the same. It figures 5 percent.

The CHAIRMAN. So that I would not be justified in drawing an inference that if you didn't make this charge for royalty on an arbitrary basis but charged only the actual expenditures for these various items, you would be in a position to sell your bottles cheaper.

Mr. LEVIS. No; they are about the same, sir. In this million dollar mythical factory which I described, the royalty would be, roughly, \$50,000. I don't believe that a small manufacturer today for \$50,000 could have adequate engineering and patent counsel and other talent, such as they buy from Hartford for that fifty.

The CHAIRMAN. Are you in such a position with respect to royalties and your relations with the Hartford-Empire that you actually have an advantage over other licensees of Hartford in the production of glass containers?

Mr. LEVIS. That is a very difficult question to answer.

The CHAIRMAN. Of course, I would say it would be a perfectly natural thing for you to try to get into that position because you are in the business of producing bottles and making money, and if you can make money out of royalties that are paid by your com-

petitors, that is a perfectly normal and natural thing for you to do. We are just anxious to find out whether that is actually the fact.

Mr. LEVIS. I might answer that by saying this, sir—that the mythical factory I said would put up \$500,000 for a furnace. I believe that the smaller manufacturers in the industry investment in their furnace is probably \$300,000, while ours, sir, is about a million. We have elaborate machine shops and machine tools for doing precision work, and a trained personnel that can operate necessarily complicated machines. In fact, on the Pacific coast, where we have built a new plant, it cost us about \$10,000,000. We have put in Hartford equipment, not because we don't believe our equipment would not be superior, but because we don't want to make the further investment for precision tools to make parts on the coast, and molds, and we aren't capable of training on the coast yet labor that can operate these complicated machines. Therefore, if we have an advantage, sir, it is because we have a different article for producing containers than Hartford licensees.

The CHAIRMAN. The whole glass industry is now in such a position with respect to demand and production and the number of plants that are going, and the method by which patents are operating, that it would be an extremely difficult thing for any new independent concern to break into the field. Is that a correct assumption?

Mr. LEVIS. No, sir.

The CHAIRMAN. You think it would be possible?

Mr. LEVIS. I think they could get in; yes, sir.

The CHAIRMAN. Where would they get the license?

Mr. LEVIS. I don't think Hartford would object to granting them a license.

The CHAIRMAN. You think that Hartford, in the light of the testimony that was given here by Mr. Smith on the opening day,¹ would be willing to grant licenses to new concerns for the production of containers, of which you say there is now an overproduction?

Mr. LEVIS. I don't see that it would be anything to Mr. Smith's advantage. In other words, he can't get any more royalty and he might as well deal with others.

The CHAIRMAN. He testified very candidly that his purpose in managing the patents and the licenses was to prevent the ups and downs in the industry, to prevent depressions, to do for the glass industry what this committee is trying to find a way of doing for all industry, if it can be done, with the preservation of the anti-trust laws. So, in those circumstances, with that purpose in mind—to protect overproduction and thereby to prevent a dropping of price—would it in all these circumstances permit a new competitor to enter the field?

Mr. LEVIS. I don't know that he would, but I believe that the Hartford Co. have always been liberal in granting licenses to anybody who should be of a business type.

The CHAIRMAN. But liberal within these broad boundaries of maintaining the stability of the industry, which is a polite way of saying of maintaining the price and of maintaining the market and of preventing competition from coming in.

¹ Testimony of Mr. F. Goodwin Smith, of Hartford-Empire Co., supra, p. 379 et seq.

Mr. LEVIS. No, sir; I don't think that is the fact, because the Glass Container Association have prepared a very interesting report on the industry, and they show that since 1920—that in 1920 there were 80 companies, and during the 18-year period 20 new companies came into the industry, 29 companies have failed or gone out of the industry, and 26 companies have been consolidated in other companies of the industry. So in 1938 we have 45 companies in the industry. All of these data that these gentlemen have prepared show schedules of this mortality, that these men who enter—

Mr. OLIPHANT. How many went out of business?

Mr. LEVIS. Twenty-nine, sir.

Representative SUMNERS. Did any of the concerns use the old method?

Mr. LEVIS. I couldn't answer that, but the report which I have a copy of here shows the mortality and the names, and from those names I could answer.

Mr. ARNOLD. Putting the same question a little differently, not in terms of guessing what Mr. Smith's policy might be or in terms of what your policy might be in case you changed it again, or some one else took your place, it is certainly true that these private companies have the power to do exactly what Senator O'Mahoney was speaking of; haven't they?

Mr. LEVIS. I don't know, sir.

Mr. ARNOLD. They have the power now to grant the licenses along the suggestions made in your letter of January 13, 1933. Now whether they do that or not is, of course, a guess, but they have the power.

Mr. LEVIS. They have the legal right not to license someone, I presume.

Mr. ARNOLD. And so this power does exist in private hands to stabilize an industry with respect to price and with respect to production. Now, I understand that you believe in using that power liberally, but the power does exist there, doesn't it?

Mr. LEVIS. I don't believe that I can answer that, sir.

Mr. ARNOLD. Never mind, let me ask you another question with respect to the charge of \$2,000,000 for royalties to yourself. It seems to almost equal the amount that you spent on research, doesn't it?

Mr. LEVIS. It is a little bit less than what we spent on research and pay to Hartford.

Mr. ARNOLD. Approximately they are equal then. Does that indicate that it would be a good patent policy as a matter of law to make the amount which could be collected on research about equivalent to the amount you collected in royalties where the invention was held by a group and where the question of equitably rewarding some particular inventor was not an issue?

Mr. LEVIS. I think, sir, you only have one qualification to that, a new business that is starting up couldn't survive with just that protection. An industry that has arrived in the stage of development that our industry has could probably consider adopting that policy.

Mr. ARNOLD. Then, with that qualification, if it is a good policy for your industry—with the qualification that you mentioned—might it not be a good legislative policy?

Mr. LEVIS. I don't believe I can answer that, sir, unless you insist.

Mr. ARNOLD. No, I wouldn't; it is an opinion. If you haven't any opinion, I wouldn't press you.

Senator KING. May I ask a question? Has your organization licensed any of its patent devices?

Mr. LEVIS. Not since 1935; I mean, their only licenses were, as Mr. Cox explained, up to about 1914, and three small licenses were granted: One in 1917 and another in 1918, and another in 1918, and in 1932 the Hazel revision.

Mr. Cox. Of course, that was a revision of the existing license. That first license to Hazel was made before 1914. It was made about 1909.

Senator KING. Do you utilize your own devices in the manufacture of glass?

Mr. LEVIS. Exclusively, sir.

Senator KING. Do you regard them as comparable to the patents of the Hartford Co.?

Mr. LEVIS. We regard them as superior, sir.

Senator KING. Why did you not use your own devices—I think you explained it; pardon me for asking if it is a repetition—in the new plant which cost you \$10,000,000 in California?

Mr. LEVIS. Because we didn't want to add further invested capital for the machine tools to take care of the necessary equipment, and we didn't have trained personnel for the operating of precision equipment.

Senator KING. What would it cost for the purpose of manufacturing necessary dies and constructing the plant?

Mr. LEVIS. Our investment has always been an investment of about a million. I believe the smaller manufacturer has an investment of \$300,000. Our investment is approximately a million, and that difference between his \$300,000 and our million is in this precision equipment, better working facilities in shops, which they engage on the outside. In other words, we manufacture corrugated boxes, they buy them; we make molds, they buy them; we make machine parts, they buy them.

Senator KING. Is it essential in the establishment of an industry to have a selling agency or to have an organization for the purpose of finding markets for the production; and, if so, state whether there is a considerable item of cost which must be taken into account in the launching of the firm?

Mr. LEVIS. Yes; we have always figured selling, administrative and general expense at about 10 percent, and we have always believed we should have our own branches which are manned by salaried people rather than commissioned employees.

Senator KING. But it would require a larger sum in the initial stages of the development of an organization than would be required later on after it had been running full blast.

Mr. LEVIS. I think it gets a little cheaper as you go along, sir.

Representative SUMNERS. I meant to ask you a question or two a moment ago, but my line of interrogation was interrupted. May I ask you this question? You speak of the installation of your factory. Do you have to make your own equipment, mechanical equipment, or is there some plant that manufactures it for the market?

Mr. LEVIS. We manufacture all of ours, sir, except certain machines that Hartford manufactures.

Representative SUMNERS. Do they have a plant where they manufacture these machines?

Mr. LEVIS. Yes; you can buy bottle-forming machines or you can make them. We make our own.

Representative SUMNERS. You spoke of the requirement with reference to exactness of the machine. Is there any market where you can buy such machines as you would like to install on the Pacific coast?

Mr. LEVIS. No, sir; not our suction machine. We are the only one who makes it.

Representative SUMNERS. Do you make that for the trade or only for yourselves?

Mr. LEVIS. For ourselves. If someone wanted a license I presume we would grant it.

Representative SUMNERS. I am trying to get the picture. Do you keep a plant that is constantly operating where somebody goes in there and says, that is the plant that manufactures machinery that makes glass?

Mr. LEVIS. We do, yes, sir; at Alton, Ill.

Representative SUMNERS. Now, if a person wanted to go into the manufacture of glass and wanted the machinery which would enable him to compete in that production, that field of activity, how many concerns could keep him from doing that if they wanted to? There is your plant, you are one sort, then there is the Hartford plant which has another sort. If those two would not be willing for him to engage in the production of glassware containers, could he do it?

Mr. LEVIS. He can buy certain other machines. The Roirant machine has been advertised in this country for years, and some of them are installed. I am informed that over 500 of them are operating in Europe.

Representative SUMNERS. Is that comparable in efficiency and economy to the machines that operate in your plant and that Hartford-Empire Co. control?

Mr. LEVIS. It is different in type from Hartford. It is about the same as our 6-arm machines, a number of which we have in operation.

Representative SUMNERS. I don't know about the six-arm machine. What I am trying to find is the one thing. A person with a factory equipped with machinery that can be bought in the open market, would he have, as a matter of competitive conditions, an opportunity to stay in the market?

Mr. LEVIS. We are operating six-arm suction machines that are about the same as the Roirant machine, at certain of our plants today. We believe that we can do that because over a period of 40 or 50 years we have trained personnel capable of doing it. I don't believe that a newcomer can just walk out and hire a glass-factory machinist and hire a glass-factory engineer and enter into this business, regardless of license restrictions.

Representative SUMNERS. What we are trying to get here on this committee is as nearly a correct picture as we can of the situation. Now, taking this machine that you have just mentioned, if three persons of equal ability were undertaking to produce glassware

containers, one who had your machine, one who had the Hartford machine, and one who had this machine that you mentioned that may be bought in the market, as a matter of practical business competition would the third man with the machine that you have just mentioned have a chance to stay in the market?

Mr. LEVIS. If he was of equal ability, he would have a chance.

Representative SUMNERS. Make everything equal; just the question of difference in machine.

Mr. LEWIS. You can't make it equal unless he can buy the engineering service from Hartford or from us.

Representative SUMNERS. Well, assuming that he can buy everything.

Mr. OLIPHANT. Assuming he can't buy from Hartford or you.

Mr. LEVIS. If he could buy that service from someone who was trained in the business—

Mr. OLIPHANT (interposing). Can't he? Isn't there such a thing?

Mr. LEVIS. I would sell it to him.

Representative SUMNERS. But I am trying to draw a distinction between human ability and machine efficiency.

Mr. LEVIS. But you lost track, sir, that the "know how" is the essential thing.

Representative SUMNERS. That is human ability. You can't manufacture it. You can train it, but you can't run it through a machine shop.

Mr. LEVIS. And very few people can acquire it.

Representative SUMNERS. But you don't get any patent right on human ability.

Mr. LEVIS. That is why you don't need a patent right if you have the "know how."

Representative SUMNERS. Let's get that pretty straight. When you, then, train a personnel, you no longer need a patent; is that right?

Mr. LEVIS. I have explained technically to Mr. Borkin—

Representative SUMNERS (interposing). Explain it untechnically, so I can understand it.

Mr. LEVIS. If I may refer to this, sir, I say: The management of the large company in an established business is not concerned regarding the license or patent or compulsory licensing laws. If a company engaged in an established business on a large scale has the right to use all inventions at a fair royalty, it would save large sums of money.

Representative SUMNERS. I quite remember that testimony. In other words, you are already established and you have your market and you have your trained personnel; if nobody else can have a patent, then you are willing not to have any patents for anybody, is that right?

Mr. LEVIS. No, sir; I don't want to make it appear technical, sir, but I can't answer it otherwise.

Mr. ARNOLD. Mr. Levis, you put in a condition that I am interested in.

Representative SUMNERS. But he hasn't answered my question, if my colleague will pardon me. I want to get this answered. You see, I am not smart like you boys. It seems to me from our stand-

point, what we are trying to find out are just a few things, and we have received a good deal of evidence on some things. First, we discover from the testimony here that there are a few big concerns that largely control the patents, that govern the manufacture of glass containers. Then, of course, there has been testimony about suits and about the notions of persons who have this control. What I want to know—and I believe my colleagues on the committee would like to know—is whether or not there is a possibility of an individual person who wants to establish a plant or factory, being able to procure the machinery that would enable him in turn to be a competitor of you people insofar as machinery is concerned. Of course, if you hire the brains, that is different. You can't patent that, I guess.

Mr. LEVIS. Or if he wants to pay us what is a fair compensation for the "know how," for the training, the engineering drawings that we have worked up in our business, we will gladly let him have one of our machines.

Representative SUMNERS. To establish a serious competition, a new serious competition for your plant?

Mr. OLIPHANT. To get that Milwaukee bottle business?

Mr. LEVIS. Oh, yes, sir.

Mr. COX. Of course, you haven't granted any license to new people in the industry?

Mr. LEVIS. There hasn't been anybody that I know of who has developed the technique capable of operating one of our machines.

Representative SUMNERS. Now wait a minute, Mr. COX, you have just been asking more questions. You know, we are just trying to get that. I would like to have it myself. If you can't answer it—

Mr. LEVIS (interposing). I can answer it, sir, if you will be patient with me and tell me what you want answered.

Senator BORAH. Let's take lunch first.

The CHAIRMAN. Before we take lunch, may I just ask one question, Mr. LEVIS? As I understood your first answer to Congressman Sumners, you said that there was one foreign machine which this mythical competitor could obtain, that it was possible, and then you compared that machine, that foreign machine, with some six-arm suction machine of yours, did you not?

Mr. LEVIS. Yes, sir.

The CHAIRMAN. That was the first time that I remember having heard anybody mention the six-arm machine. Now my own question to you is this: Is that six-arm machine your most efficient machine?

Mr. LEVIS. Yes and no. It is the most efficient for making a variety of various sizes for scheduling, and less efficient for making long straight runs. In other words, we couldn't operate our factory without it, and we couldn't operate and be competitive exclusively with it.

The CHAIRMAN. And how many other machines do you use in comparison with this, proportionately?

Mr. LEVIS. It is all to the capacity, sir. We have 15-head machines that make two bottles at a time and 10-head machines that make two and a half, and six-head machines.

The CHAIRMAN. But the answer to the original question of Judge Sumners is this: That a competitor who was using only that single foreign machine (since it is comparable to your six-arm machine

which is a machine which, while necessary for your business, is not sufficient to enable you to maintain it as a whole) would not be able to enter the field in which you are operating.

Mr. LEVIS. No one else has ever sought to enter the field we are operating.

Representative SUMNERS. Could you make milk bottles? Could you stay in business using that sort of machine making milk bottles in competition with an organization like Owens?

Mr. LEVIS. Yes, sir.

Representative SUMNERS. Have you really got my question? By using this machine that you have just been discussing, a competitor could successfully compete with you, using your other machinery and making milk bottles?

Mr. LEVIS. Mr. Representative, I don't believe anybody could successfully compete with me in this thing. It isn't just a machine.

Representative SUMNERS. I know. They couldn't get your ability, possibly, and I am not speaking facetiously at all; we appreciate that, but we are talking about machinery now. That is what the patent is on, you know. We are not talking about nice personnel and good lawyers and efficient people; we are talking about machinery. If that is so, why don't you use that machinery instead of the other kind you use?

Mr. LEVIS. We do.

Representative SUMNERS. I mean to make milk bottles.

Mr. LEVIS. Because we happen to make milk bottles at Columbus and Clarion and probably it would cost us \$1,000,000 to take the machine out and put this in.

Representative SUMNERS. Is that a new machine?

Mr. LEVIS. Newer than the ones we are operating. But, sir, it isn't the machine. I can take good personnel and a 20-year-old machine and make bottles more efficiently than an average personnel and a modern machine.

Representative SUMNERS. Why have patents around here been bothering people anyhow?

Mr. LEVIS. I am not bothering them. I stated my patent policy yesterday.

Representative SUMNERS. Some people are concerned about keeping patents and we had a notion that maybe patents had something to do with efficient manufacturing, but I guess I am wrong.

Mr. LEVIS. I don't think that; others may.

The CHAIRMAN. Judge Sumners has assumed the equality of personnel. Now, with that assumption, taking out of consideration, therefore, all this "know how" business, assuming that the personnel is absolutely equal in competency and efficiency, then the question comes down to this. Could a competitor who is compelled to use exclusively the foreign machine and cannot use this other machine which you have, successfully compete with you?

Mr. LEVIS. If the question is, "Could he successfully stay in business?" then I can say he can. If you ask, "Can he successfully compete with me?"—

The CHAIRMAN (interposing). Why do you change the question?

Mr. LEVIS. If the question is, "Can he successfully compete with me?" I don't know.

Senator BORAH. You are not afraid?

Mr. LEVIS. Not a bit, sir.

Senator BORAH. That would be true if there were no patents whatever?

Mr. LEVIS. That is right, sir.

Senator BORAH. If there were no patents whatever, then the manufacture of milk bottles would go on just the same?

Mr. LEVIS. That is right, sir.

Senator KING. Would a person with limited capital, even if he had all of the engineering ability and the "know how" to which you have referred, be inclined to go into business and establish a plant if the existing facilities created an over-production?

Mr. LEVIS. I don't think that he would.

Senator KING. Wouldn't that influence a person in going into business, whether there was any available market for his commodity?

Mr. LEVIS. It is more influencing to him, though, sir, than the patent situation.

Senator KING. A man, if he is going into any business, whether it is building a smelter or opening a mine or building a shoe factory, wants to know whether he has a market, and if the market is surcharged with commodities which cannot be sold except at a loss, he isn't disposed to invest his capital. Is that right?

Mr. LEVIS. It is, sir.

Senator KING. It is a business proposition, business common sense, whether you go into business when you find that the market is over-supplied.

Mr. LEVIS. That same man might be a greater success in some other field.

Mr. ARNOLD. Then, as I get the substance of your testimony, it is this: Since both you and the Hartford-Empire are really selling research and brains, since you have this established organization which has concentrated them to a high degree, then neither you nor the Hartford-Empire need any patent to preserve your present position.

Mr. LEVIS. I can't answer for Hartford, sir.

Mr. ARNOLD. That would follow from your testimony that you have just given.

Mr. LEVIS. I don't think I have ever attempted to answer for Hartford.

Mr. ARNOLD. Would that not follow from your present testimony?

Mr. LEVIS. I can't answer that, sir.

Mr. OLIPHANT. But, answering for yourself?

Mr. LEVIS. I don't believe, being an established business, sir; if it were a new development, a new industry, it must have that protection in order to create an incentive for genius, an incentive for capital to develop. It is a good deal like the excess-profits tax or the undistributed-earnings tax. If you have got plenty of money you don't worry. If you have to go borrow the money to pay it, it does worry you.

Mr. OLIPHANT. Why were you worried about the piece of Milwaukee business? Did you get that business?

Mr. LEVIS. I wasn't worried about it. I inquired as I would about a lot of things.

Mr. COX. You have that business now, don't you?

Mr. OLIPHANT. Did you get the Milwaukee business?

Mr. LEVIS. I couldn't tell you. We have some beer bottle business in Milwaukee, but not all of it.

Mr. OLIPHANT. Let me ask a little along the lines suggested by the Congressman. Suppose Henry Ford decided he wanted to go into the business of making nursing bottles for babies so the poorest could have the best. Would Hartford-Empire and you have the power to refuse to give him licenses?

Mr. LEVIS. No, sir.

Mr. OLIPHANT. You wouldn't have that legal right?

Mr. LEVIS. Yes, sir.

Mr. OLIPHANT. You would have to give him the license?

Mr. LEVIS. We are not the only grantors of licenses, sir.

Mr. OLIPHANT. But of the machines controlled by those two organizations.

Mr. LEVIS. If he wanted our machine, I presume we would have the option of telling him whether or not he could have it.

Mr. OLIPHANT. Suppose he thought your action was arbitrary, could he appeal to anybody from your decision?

Mr. LEVIS. Not much difference, sir, than if he liked my house on Parkwood better than his own and wanted it.

Mr. OLIPHANT. But your house on Parkwood is not 97 percent of the houses of the United States.

Mr. COX. It wasn't given you by the Government.

Mr. LEVIS. My business wasn't.

Mr. COX. Your patents are.

Mr. OLIPHANT. Could he appeal to the Supreme Court if he thought your action was arbitrary and unreasonable?

Mr. LEVIS. Sir, I stated yesterday, he can build an Owens machine. We have no patents covering the Owens machine, sir. They are about all gone. I said we had only one that amounted to anything, and that was the stationary pot, and that we were still operating revolving pots, trying to find a way to make them stop revolving. We have done it in a small way. There isn't any way a man with brains who wants to build an Owens machine can't go build one, and enter into competition with us, and I am not afraid if he does.

Senator KING. Mr. Ford could build an Owens machine if he wanted to?

Mr. LEVIS. Yes, sir.

Senator KING. Or anybody else?

Mr. LEVIS. Yes, sure; Mr. Ball operates a number of them which he has had and the patents have expired. We don't need a court or anything.

The CHAIRMAN. The Senator from Utah suggests that the time has come to take a recess.

Mr. PATTERSON. Will Mr. Levis be on this afternoon?

The CHAIRMAN. Do I understand that Mr. Levis will be back this afternoon?

Mr. COX. Yes.

The CHAIRMAN. We recess until 2 o'clock.

(Whereupon, at 12:25 p. m. a recess was taken until 2 p. m. of the same day.)

AFTERNOON SESSION

The committee resumed at 2:15 p. m. on the expiration of the recess, Senator O'Mahoney (chairman) presiding.

The CHAIRMAN. The committee will please come to order.

Mr. COX, will you resume your examination?

TESTIMONY OF WILLIAM E. LEVIS, PRESIDENT, OWENS-ILLINOIS GLASS CO., TOLEDO, OHIO—Resumed; AND LLOYD T. WILLIAMS, COUNSEL, OWENS-ILLINOIS GLASS CO., TOLEDO, OHIO—Resumed

Mr. COX. Mr. Chairman, I should like to offer now a letter which I read into the record this morning, dated January 13, 1933, written by Mr. Levis to Mr. F. Goodwin Smith.

(The letter referred to was marked "Exhibit No. 128" and is included in the appendix on p. 781.)

Mr. COX. Mr. Levis, I asked you to check some facts with respect to the free feeders you had under the 1924 agreement. Will you tell us what you found out?

Mr. LEVIS. Yes, sir; during the recess, Mr. Phillips, our vice president and treasurer, advised me that there were 15 feeders that we used under the free provision of the 1924 contract.¹ Ten of them were at the Evansville plant working in connection with Owens A. W. machines, which plant was closed prior to 1932. Five of them at Huntington. Therefore, there were approximately 15 feeders in which that right was exercised.

Mr. COX. I also understood you to testify before the committee rose that it was the policy of your company now to grant licenses to persons who applied for licenses under your patents.

Mr. LEVIS. I don't think we have any policy, Mr. Cox, but we would not refrain from granting a license to someone who applied.

Mr. COX. Was that like the other policy that I described this morning?

Mr. LEVIS. No, sir; I don't think we would change our minds on that.

Mr. COX. That is not a recent development?

Mr. LEVIS. No, sir.

Mr. COX. Well now, Mr. Levis, I want to read to you some correspondence which was given to us by your company. The first is a letter dated June 8, 1935, addressed to the Owens-Illinois Glass Co., Toledo, Ohio, and reads as follows [reading from "Exhibit No. 129"]:

✓ I have under contemplation the erection of a glass factory with a view to manufacturing a line of goods in keeping with the requirement of such retail entities as Woolworth, et al. I understand that you and Hartford-Empire control the fabricating machinery incidental to the equipping of a plant for the output of such products, and that it is necessary to arrive at terms with you before such machinery is obtainable. I would therefore appreciate hearing from you and being advised as to the course I should pursue initially.

I am also going to call your attention to the following letter, dated June 17, 1935, which was apparently signed by Mr. Martin, assistant

¹ See supra, p. 495.

secretary of your company, and reads as follows [reading from "Exhibit No. 130."]:

Referring to your communication of June 8, this company is engaged in the manufacture and sale of glass containers, but we are not licensors of glass-making machinery. We do construct certain glass-forming mechanisms, but such equipment is for use in our own factories exclusively. We are unable, therefore, to render the service which you require.

It is signed by Mr. Martin, assistant secretary, and I ask you whether you will identify those documents as having been taken from your files. I call attention to the certification.

Mr. LEVIS. Mr. Martin can; I can't.

Mr. Cox. Could we have Mr. Martin come forward and identify these? May I have Mr. Martin sworn, please?

The CHAIRMAN. Mr. Martin, do you solemnly swear that the testimony you are about to give in these proceedings shall be the truth, the whole truth, and nothing but the truth.

Mr. MARTIN. I do.

TESTIMONY OF E. F. MARTIN, ASSISTANT SECRETARY AND ASSISTANT TREASURER, OWENS-ILLINOIS GLASS CO., TOLEDO, OHIO

Mr. Cox. Will you examine those documents and see if you can identify them as having been taken from your files?

Mr. MARTIN. Yes; they are copies of letters taken from our files.

Mr. Cox. Very well, I should like to offer these letters in evidence.

(The letters referred to were marked "Exhibits Nos. 129 and 130" and are included in the appendix on pp. 781 and 782.)

The CHAIRMAN. The letters may be admitted as requested.

Mr. Cox. Mr. Martin, I now call your attention to a letter which I shall show you in a moment, dated June 25, 1934, addressed to Mrs. Len Smith, 960 South Oxford Avenue, apartment 325, Los Angeles, Calif. [reading from "Exhibit No. 131"]:

Your letter of June 14 addressed to our Chicago sales office has been referred to this department.

For the past several years we have not built the Owens Machines for use outside of our own company, and we regret, therefore, that we are unable to furnish you with particulars concerning this type of bottle-building mechanism.

Mr. Cox. I ask you whether you can identify that as a copy of a document which was taken from your files?

Mr. MARTIN. Yes; that was taken from our file.

Mr. Cox. I now call your attention—first, I should like to offer that letter, if I may.

(The letter referred to was marked "Exhibit No. 131" and is included in the appendix on p. 782.)

The CHAIRMAN. It may be admitted.

Mr. Cox. I should now like to call your attention to a letter dated December 10, 1934, which reads as follows [reading from "Exhibit No. 132"]:

Referring to your communication of November 30, this company does not manufacture glass-making machinery for use outside its own plants.

Mr. COX. I ask you if you can identify that.

Mr. MARTIN. Yes, sir.

Mr. COX. I should like to offer this letter, too.

The CHAIRMAN. The letter may be admitted.

(The letter referred to was marked "Exhibit No. 132" and is included in the appendix on p. 782.)

Mr. COX. I should like to state for the record that the letters which elicited the replies which are contained in the last two exhibits, which would be letters addressed to the Owens-Illinois Co., our investigators for some reason were not able to find. However, if Mr. Martin can find them, I should be glad to add them to the exhibits.

Mr. MARTIN. Letters we received from these people?

Mr. COX. Yes; to which these letters apply.

Senator KING. Is it your intention to show it was the duty of this company or any company that had a patent to manufacture a machine at small cost; that they must continue to manufacture them for other persons?

Mr. COX. Certainly not.

Mr. ARNOLD. The Department of Justice isn't at all interested in the present duties at all.

Senator KING. Then there is no legal obligation to manufacture these costly plants for other persons?

Mr. ARNOLD. May I answer that, Senator?

Senator KING. I wanted to ask if that was the purpose of his question.

Mr. COX. That is my understanding of the law, that there is no legal duty to manufacture anything.

Senator KING. You have answered my question. I think you are right.

Mr. COX. Mr. Levis, at one point this morning you and I were talking about your interest in stabilizing the industry, and I was about to inquire whether in that connection you regarded the elimination of price cutting as something which led to stabilization.

Mr. LEVIS. If I ever did, Mr. Cox, it hasn't in my opinion amounted to much, because there is and always has been price cutting.

Mr. COX. Has it ever been your policy to encourage the use of patents or patent rights to prevent price cutting?

Mr. LEVIS. I know of no case where we have coupled with a patent or license any control of price.

Mr. COX. I am thinking now particularly perhaps of the use of patent or patent rights by others.

Mr. LEVIS. Would you give me an example?

Mr. COX. I have another letter here, Mr. Levis, which you wrote to your Uncle Harry, R. H. Levis, is that right?

Mr. LEVIS. Yes, he is my uncle; he still is.

Mr. COX. This letter is dated August 2, 1932, addressed to Mr. R. H. Levis, Illinois Glass Consolidated Corporation, Alton, Ill. I am going to read two paragraphs and then I will give you the letter to examine. [Reading from "Exhibit No. 133"]:

As I see the situation now, it appears that we are on the eve of straightening out the Hartford patent situation. Hazel-Atlas has come in and taken a license, and yesterday the Knox Glass Co. agreed to come in, pay back damages,

and take a license. In so doing they have withdrawn from the Miller Feeder Users Defense Association, and other Miller feeder users have expressed their willingness to come in and take a Hartford license if Knox and Hazel-Atlas took a license from Hartford. The only important manufacturers who remain out of Hartford's licensing plan are Ball Bros. and the Root Glass Co. We are negotiating with both of these companies and I am quite confident that they will come in if all of the other feeder operators come in, if for no other reason than to protect fruit jar licensing, as well as to curtail the licensing of beverage bottle manufacturers.

With the plans we now have, there is certain to be a curtailment of the promiscuous manufacture of milk bottles on nonlicensed feeders, which will result in our company's and the Thatcher Co.'s securing a greater proportion of the available milk bottle business. This should stabilize the price and increase the earnings of the Thatcher Co.

I ask you if that is a letter which in fact you wrote to Mr. R. H. Levis.

Mr. LEVIS. Yes, sir.

Mr. COX. Now Hazel-Atlas did thereafter, to use your word, come in and take a license, didn't they?

Mr. LEVIS. Yes, sir.

Mr. COX. And Knox took a license, did it not, from Hartford-Empire?

Mr. LEVIS. Yes, sir.

Mr. COX. And Ball Bros. took a license afterward from Hartford-Empire, did they not?

Mr. LEVIS. Yes, sir.

Mr. COX. I should like to have this letter marked.

The CHAIRMAN. The letter may be admitted.

(The letter referred to was marked "Exhibit No. 133" and is included in the appendix on p. 782.)

Mr. COX. Mr. Levis, this morning we were talking about the Roirant machine, the French machine. Do you know anything now about the patent situation with respect to that machine? Is it covered by any patents which are owned by any manufacturer who is now manufacturing glass?

Mr. LEVIS. No. As near as I know they are a company who have offices in Paris, who have offered the machine for sale in this country through advertisements in trade magazines for the last several years. We have one of the machines.

Mr. COX. Do you recall having conversation with Mr. Bracken, of Ball Bros. Co., in September or August of 1935, about the patent rights on that French machine?

Mr. LEVIS. I don't recall the conversation with Mr. Bracken, but I recall the circumstances. I couldn't identify it as to him.

Mr. COX. You don't ever recall having stated to Mr. Bracken that that machine was covered by some patents which the Owens-Illinois Co. owned, so that the use of the machine would infringe those patents?

Mr. LEVIS. Not the Roirant machine—I don't recall. I recall the Moorshead machine was involved.

Mr. COX. Mr. Levis, I have a letter here, a certified copy of a letter which was taken from the files of Ball Bros. Co., written by Mr. F. C. Ball to Mr. McCallister, who testified yesterday, in which Mr. Ball makes this statement. I am going to read it to you and ask you if it refreshes your recollection as to that conversation. This

letter is dated September 14, 1935, and is addressed to Mr. E. W. McCallister, Grant Building, Pittsburgh, Pa.

Mr. Levis, president of the Owens-Illinois Co., stated to me over the telephone that the Roirant machine which dips from a hearth extending from the furnace could not be used in America owing to the fact that his company secured in their purchase from the O'Neill Machine Co. patents covering this extension hearth for feeding glass.

Do you have any recollection of that?

Mr. LEVIS. I haven't any recollection of it, but I do know that that is the O'Neill stationary pot machine, but the Roirant machine doesn't use that. It is a revolving machine of the same type as our Owens six-arm machine, and it runs from a revolving pot. The single-head Roirant machine, which would probably be impractical except for small orders, dips into a stationary pot. If Mr. Ball is referring to the single-head machine, his statement is correct; if he is referring to the machine I have been talking about, it is incorrect. The six-arm Roirant machine, which runs from a revolving pot and which anybody can have for the asking, is the one I am talking about. If this statement is made with respect to the single head, it would be accurate. I have no independent recollection. If Mr. Ball would ask me that question today I would tell him that if he dipped from a stationary pot of a construction as covered by the O'Neill patent, I would believe it were an infringement.

Mr. Cox. And to the extent that anyone wanted to use that process they would have to get a license?

Mr. LEVIS. Yes, sir; but in that same connection Mr. Ball wanted to bring in the Moorshead machine, which interfered with a patent which we own, a bock patent, and we gave Mr. Ball the release in order that he could bring in the Moorshead machine into this country.

Mr. Cox. When was it that you did that?

Mr. LEVIS. Three or four years ago. We even sent in the engineers' reports that our engineers made on the Moorshead machine, so he could see them before he took it.

Mr. Cox. Ball Bros. got exclusive rights for that machine, didn't they?

Mr. LEVIS. I had nothing to do with it other than to give them our report.

Mr. Cox. You don't know whether they had exclusive rights?

Mr. LEVIS. I don't know.

Mr. Cox. I think they did. Now, I want to ask you a few more questions, and then I think I will have about finished, about certain cooperative activities between the Owens Co. and the Hartford-Empire Co. under the 1924 agreement as made. If you don't know the answers, perhaps Mr. Martin will be able to answer the questions.

It is true, is it not, that after that contract was made, the two companies cooperated to the extent of sharing the expense of suing infringers?

Mr. LEVIS. I would prefer Mr. Williams answering up until '29. I will go from '29 on.

Mr. Cox. Very well; can you answer that question?

Mr. WILLIAMS. I am sorry; my mind was diverted for a moment. I heard only half the question.

Mr. Cox. Perhaps, Mr. Levis, I might give to you and to Mr. Williams this memorandum which I think, if you have it before you, will assist you in answering these questions. This memorandum was written by Mr. Carter to you, dated April 12, 1930, and is entitled "Status of patent infringement suits now pending."

Will the reporter read for Mr. Williams the question which I asked a moment ago?

(The reporter reread Mr. Cox's last question.)

Mr. WILLIAMS. That is true; yes.

Mr. COX. For example, Mr. Williams, there was a suit brought by Hartford-Empire in the Federal court in St. Louis in 1926 against Obear-Nester, and the two companies shared the expense of that suit.

Mr. WILLIAMS. I can't answer in detail, Mr. Cox, as to whether participation was had in any particular suit, or the extent of it. I simply know there was participation.

Mr. COX. I think if you look at that memorandum, which I assume is correct, you will see that these suits are listed there.

I ask you again if that doesn't refresh your recollection as to the Obear-Nester suit.

Mr. WILLIAMS. I won't say it refreshes my recollection. I don't know that I ever knew what particular cases or what particular suits they participated in. I know Owens did participate in the expense.

Mr. COX. Perhaps we can solve this this way: Mr. Martin, are you prepared to identify that as a photostatic copy?

Mr. WILLIAMS. The statement is made in the letter that we did participate in the St. Louis suit, and I assume it means the *Obear-Nester case*.

Mr. COX. This is dated April 12, 1930, and states that Hartford-Empire and Owens-Illinois shared the expenses of suits brought by Hartford-Empire against Obear-Nester Co., not one suit there but two, one brought in 1928 and one in 1929; the expenses of the suit brought by Hartford-Empire against Nivison-Weiskopf, 1926; a similar suit against Kearns-Gorsuch Co., 1926; the expenses of a similar suit brought by Hartford-Empire against the Lamb Glass Co.; the expenses of a similar suit brought by Hartford-Empire against the Hazel-Atlas Co.; and the expenses of a similar suit brought by the Hartford-Empire Co. against the Reed Glass Co. I should like to have this memorandum admitted in evidence.

The CHAIRMAN. The memorandum may be admitted.

(The memorandum referred to was marked "Exhibit No. 134" and is included in the appendix on p. 784.)

Mr. COX. Now, do you know, Mr. Levis, the circumstances under which Hartford-Empire and Owens-Illinois, after 1924, shared the expense of acquiring certain patent rights and the assets of certain other companies engaged in manufacturing glass-making machinery?

Mr. LEVIS. No. Mr. Williams does.

Mr. COX. I shall address these questions, then, to Mr. Williams. Can you tell us, Mr. Williams, if it is not a fact that the two companies contributed equally to the cost of acquiring the William J. Miller Engineering Co. and the patent rights of William J. Miller?

Mr. WILLIAMS. No, not the company, but the patent rights. What we acquired there, principally if not entirely, was relinquishment of

Miller's rights in the Patent Office interferences. We had been in interference there, both Hartford and Owens, on patents for quite a long time—extensive hearings, and quite expensive, and I may say that in the negotiations in which I participated in part the statement was made by Miller's attorney that he hadn't any great expectations of getting a patent out for Miller, but it would keep us in the Patent Office for 5 years, and it was quite important to us to get our patents out, and we bought Mr. Miller's position in the Patent Office.

Mr. Cox. And shared the expense equally.

Mr. WILLIAMS. That is right.

Mr. Cox. Then you bought patents to a feeder known as the Tucker, Reeves & Beatty feeder, and the expense of that acquisition was shared by the two companies.

Mr. WILLIAMS. That is correct. We were in much the same situation there, in long-winded interferences and particularly with reference to Hartford's patent and our own. We couldn't get the patents out, and licensees were becoming very much dissatisfied.

Mr. Cox. Now I come to the O'Neill Machine Co., Mr. Williams. That was a case where Hartford purchased all the patent rights covering gob feeding and forming machines, and the Owens Co. purchased the remainder of that business, including the patent rights relating to suction machines. Is that right?

Mr. WILLIAMS. I think that is right.

Mr. Cox. So that when the transaction was over the two companies between them owned everything that the O'Neill Machine Co. had previously owned—patent rights and physical assets.

Mr. WILLIAMS. That was true only as to the United States patents. We didn't purchase O'Neill's foreign patents.

Mr. Cox. Now I come to the Whitall Tatum patent rights on forming machines. That acquisition was one that was financed by the two companies in equal shares, was it not?

Mr. WILLIAMS. Yes; that is frequently referred to as the Headley and Thompson application. I hate to refer to interferences so much, but there again was a situation in which Headley and Thompson had some very broad claims on forming machines, and I think on the feeders, at least upon the joint use of the two as a unit. Owens was in interference, Hartford, I think, two or three others. The claims were such that if allowed they would have absolutely overlain not only the use of the Hartford feeder, but also the use of the Graham machine which we were trying to develop, and which we did develop through three successive stages that we called, as they got larger, the A. W., A. Y., and A. Z. machines. I think I told you something about their exploitation, especially abroad. The transaction was that Hartford took an option from Headley and Thompson—no, from Whitall Tatum Co., which owned the Headley and Thompson application and was pursuing its allowance in the Patent Office to have either an exclusive or nonexclusive license, as Hartford might elect when the patents came out and the Hartford people could make up their minds how valuable the patents would be, and we paid a certain sum—I have forgotten for the moment—each year to maintain that option, and Owens participated half and half.

Mr. COX. I want to ask you, I think for the sake of the record, to give us the year, if you can, when the William J. Miller patent rights were acquired.

Mr. WILLIAMS. That was in July 1925.

Mr. COX. And that was a going concern, manufacturing machinery, at the date of that acquisition?

Mr. WILLIAMS. Yes. We didn't acquire Miller's business, however, just his patent rights, his applications in the Patent Office. That is what we acquired.

Mr. COX. When was Tucker, Reeves & Beatty acquired?

Mr. WILLIAMS. That was in August of the same year, 1925.

Mr. COX. When was the O'Neill Machine Co. acquired? That was in 1933, wasn't it?

Mr. WILLIAMS. 1933, I think; yes.

Mr. COX. When were the Whitall Tatum rights acquired?

Mr. WILLIAMS. The option of which I spoke was abandoned, and the Headley and Thompson patents in the hands of Whitall Tatum were purchased—I have a very bad memory for years.

Mr. COX. I think that was 1933 too.

Mr. WILLIAMS. I thought it was '34; 1933 then.

Mr. COX. Very well. Now, I wish to touch briefly on one more of these transactions, and that is the one relating to the Ed Miller Machine & Mold Co. Do you know whether that company manufactured glass machinery?

Mr. WILLIAMS. It manufactured glass working machinery; yes. I think they were principally in the press, and press and blow machines.

Mr. COX. And that company was bought by the Lynch Corporation, is that correct?

Mr. WILLIAMS. Yes.

Mr. COX. In order to eliminate details, some of the details of that transaction, would it be accurate to say that Hartford-Empire Co. and Owens-Illinois between them furnished the money which the Lynch Corporation used for that acquisition?

Mr. WILLIAMS. I do know about it; I think Mr. Levis can tell that better than I can. I drew some of the papers, but I have forgotten some of the details.

Mr. LEVIS. Hartford bought the feeder rights involved and Owens bought the suction rights involved, and there was a sale of shares of about \$200,000 in cash in which I was one of the underwriters.

Mr. COX. And with that money the Lynch Corporation obtained, it bought the Ed Miller Machine & Mold Co.?

Mr. LEVIS. Yes, sir.

Mr. COX. I want to ask a few brief questions about the acquisition by Owens-Illinois of two other companies: One is the Atlantic Bottle Co. Do you remember the circumstances of that acquisition? I am asking you if you do remember it, that is all.

Mr. LEVIS. Yes; I do remember it.

Mr. COX. That was a company which had been notified that it was infringing the patents of Hartford-Empire?

Mr. LEVIS. Yes, sir; it was a member of the Miller defense group.

Mr. COX. A member of the Miller defense group. And after that notification, you purchased the assets of the company and made settlement with Hartford-Empire as to the infringement claims?

Mr. LEVIS. We purchased the assets subject to a settlement being made, and that settlement was subsequently made.

Mr. Cox. And I now want to call your attention to the Rawleigh Glass Co. They used a Nivison-Weiskopf feeder, was it not?

Mr. LEVIS. I don't know what feeder the name was, but they used a feeder.

Mr. Cox. And that company was notified that they had infringed the Hartford-Empire Co.?

Mr. LEVIS. Dr. Rawleigh told me that.

Mr. Cox. And you then bought the assets of the company and made an adjustment with the Hartford-Empire?

Mr. LEVIS. No, sir; we got—it wasn't the company, sir. They are worth as much as we are. We couldn't have bought it. It was a bottle factory that they had to make their own bottles, and it hadn't been operated for 2 or 3 years.

Mr. Cox. Just what did you buy?

Mr. LEVIS. We bought some old batch handling devices and some machines and trucks and mold shop equipment, a couple of Keller cutting machines, a lot of assets.

Mr. Cox. And did you settle an infringement claim that the Hartford-Empire Co. had against that company?

Mr. LEVIS. No; I think he settled the claim. We might have assisted him in doing it.

Mr. Cox. Did you write him'?

Mr. LEVIS. I don't know; there are some letters that I saw at that time that I think he wrote. I don't think I wrote any.

Mr. Cox. I will show you a letter and ask you if this doesn't refresh your recollection that you talked to Mr. Goodwin Smith about settlement of that infringement claim before the acquisition.

(Mr. Cox submitted a letter to Mr. Levis.)

Mr. LEVIS. Yes, sir; that is my letter.

Mr. Cox. That refreshes your recollection that you did discuss the claim with Mr. Goodwin Smith prior to the acquisition, and then you did settle it afterwards.

Mr. LEVIS. Yes, sir. I don't think there were any settlement papers drawn, sir. There may have been.

Mr. Cox. One more thing that I want to ask you. Yesterday we heard some testimony about the Westlake machine. That machine is covered by some patents which your company owns, is it not?

Mr. LEVIS. They are owned in the name of the Libbey Glass Co.

Mr. Cox. And the last one of those patents expires in 1942, is that correct?

Mr. LEVIS. I presume so, but there shouldn't be any very important patents on it.

Mr. Cox. There isn't, but there are some patents that expire in 1942?

Mr. LEVIS. Not to go into detail, but there are two different groups of patents. There are the machine patents and there is the so-called burn-off patent. That is the patent that severs the top of the tumbler and forms the edge. The burn-off patent has some value.

Mr. Cox. They are still in existence?

Mr. LEVIS. Yes.

Mr. COX. I think that is all as far as I am concerned.

The CHAIRMAN. Do any members of the committee desire to ask Mr. LEVIS any additional questions?

Mr. PATTERSON. Mr. LEVIS, you touched on the French machine a little while ago and that reminded me to ask you one or two questions on the foreign market situation with reference to your business. I should like to ask if any of your glass-making equipment or processes which you use are subject in any way to control by foreign individuals or by foreign firms?

Mr. LEVIS. Well, a number of years before I came to the Owens Co. they sold their European rights to their developments and machines to the so-called European Verband Co. That resulted in some litigation which was settled along about 1930 which resulted in a 10-year period to run from then in which they had the right to the then existing patents with nonexporting arrangements; that is, they could not export the products of that machine into our territory and we could not into their territory, but I might add that it never has been a very practical thing because of the service features in containers. There is very little import of the type of containers that we manufacture, nor could we export to advantage in their territory.

Mr. PATTERSON. Now, also for the record, have any of the glass-making processes or equipment which you control been leased, sold, licensed, or in any other manner made available to foreign manufacturers?

Mr. LEVIS. Yes; we have sold our equipment and have licensed manufacturers under our suction equipment.

Mr. COX. In what countries, Mr. LEVIS?

Mr. LEVIS. Well, you can explain that, Lloyd, better than I can.

Mr. WILLIAMS. I will have to go back a little so you will understand names. The basis of the Owens suction machine was the invention by M. J. Owens of what we call the suction feed. Up to his time, while there were semiautomatic machines that they had that helped somewhat in the blowing of a bottle, no one had ever mechanically gotten the molten glass out of the tank into the mold even where they had a semiautomatic machine. It took an expert gatherer with a punty rod to reach into the furnace and get a gob of glass and pull it out and drop it into the mold, and he had the problem of getting the right quantity, whether he wanted 2 ounces or 2½ or 5 or 10. Owens was the first one to get the glass mechanically from the tank to the mold.

Mr. E. D. Libbey backed him with the finances and in 1895 they organized the Toledo Glass Co. to carry on Owens' experiment. They finally got a bottle machine that would work about 1903, and then the Owens Bottle Co., or rather the Owens Bottle Machine Co., was organized at their instance to take the exclusive United States license for the use of those patents. Then the foreign rights still belonged to the Toledo Glass Co. Some of them were directly sold as in Canada, Dominion Glass Co.; sold to Mexican firms, and later, I believe, the rights were sold in Japan. Then they organized the Owens European Bottle Co. to which they transferred all the rest of the foreign rights, and that concern then sold those rights to the Europaischer Verband Der Flaschen Fabriken, Ltd., or G. M. B. H.

As Mr. LEVIS said, there was some litigation that arose later between the Verband and the Owens Bottle Co.; the Verband claiming

the improvements of the Owens Bottle Co. That was denied. It was not a party to the European agreement, but it was settled and did give them—settled about 1930 after litigation in the Federal courts—the inventions which we then had and were expressed either in patent form or in application form. We had quarreled over words and indeterminate phrases, so we limited it to those things in writing or in patents or in application form in this country. They could have Europe as their territory.

Then there is one more thing about it, if you care to know.

Mr. PATTERSON. Yes, surely.

Mr. WILLIAMS. When the Owens Co., in 1916, acquired the rather inchoate invention and ideas of Joseph Graham, he was using a rather crudely developed automatic machine and feeder. Owens Co. took those and developed them and their first development they called the A. W. Graham type machine. Rights and machines were sold for use in Sweden, in Brazil, rights were sold in Canada. I have forgotten whether machines went there, and then on the second or larger development, something like a 10-arm machine, rights were sold to the Soviet Glass Trust. I have forgotten the name for the moment. It was in Russia. Rights were sold and a machine or two or three delivered in Cuba. That, I think, about completes our foreign developments.

Mr. PATTERSON. Thank you, Mr. Williams.

There is just one other question, possibly two, which I have. Has your company entered into any agreements which in effect restrict exports and imports of glass products from or to the United States?

Mr. WILLIAMS. The only one I recall is the settlement made with the Verband, settling the pending case in the United States Circuit Court of Appeals for the Sixth Circuit, and there was the agreement that neither would export ware into the territory of the other. As Mr. Levis says, there has been practically no exportation of empty bottles back and forth because they aren't a commodity that lends itself well to export. That, I think, is the only agreement we have ever had and, as far as I know, no bottles have ever been exported to Europe. In any event they can make them as cheap over there as we can and vice versa.

Mr. PATTERSON. That leads me to this question. What is the basic policy of your firm, if you have any, in allocating foreign markets to foreign licensees? Is there such a policy?

Mr. WILLIAMS. No; these machines that I tell you about that were sold—these A. W. machines in Sweden about 1917; the last, I think, was the Russian, something like 1924 or 1925—I don't recall if in any of those agreements we had nonexport provisions. The only one I now recall, I may be in error, was in the Verband settlement, and it was of practically no moment because empty bottles can't be carried across the ocean profitably.

Mr. PATTERSON. That is all. Thank you, Mr. Williams.

The CHAIRMAN. Mr. Sumners, do you want to ask the witness anything?

Representative SUMNERS. No, sir.

Senator BORAH. How many firms are there in the United States manufacturing milk bottles?

Mr. LEVIS. I think Mr. Smith stated in his testimony day before yesterday, 10.

Senator BORAH. What proportion of those milk bottles are produced by yourself and by the Empire patents, those under the Empire patents?

Mr. LEVIS. So far as I know, they are all produced under machines that are under the Hartford-Empire patents. We can produce them on our suction machines, sir, but there is color and service and style and items of that kind, and the Hartford-Empire machines seem to be better equipped to produce them than our larger suction machines.

Senator BORAH. How is the price of milk bottles fixed in the United States?

Mr. LEVIS. I guess by competition, sir.

Senator BORAH. Are you sure about that?

Mr. LEVIS. I hope so.

Senator BORAH. Well, I hope so, too. Do you think milk bottle prices are fixed in the competitive world?

Mr. LEVIS. Well, I can answer it this way, sir. Milk bottles, beer bottles, and soda bottles are a type of glass container that is what we call a reuse item. It doesn't make much difference to the purchaser of that whether he pays \$10 a gross or \$2 a gross. Its only question of price is as to the cost per trip. If my milk bottle will give 100 trips, it is worth 50 times more than one that gives 2 trips. It is a question of style and color and quality. All we have are the Department of Agriculture's figures which show that the average last year was 34 trips. Our selling price on a quart bottle is \$5.33 a gross which would be \$0.00109 each, one-tenth of a cent, on the Department of Agriculture trips.

The CHAIRMAN. What is that figure again?

Mr. LEVIS. \$0.00109, roughly a tenth of a cent, roughly a mill.

The CHAIRMAN. Per trip?

Mr. LEVIS. Per trip; yes. On 34 trips at \$5.33 per gross.

The CHAIRMAN. That is what the statistician would call the trip bottle.

Mr. LEVIS. Well, sir, they are all that. Coca-Cola's average of their parent company-owned plants was 110 trips per bottle last year. I have seen dairies in thrifty places like St. Louis and Milwaukee run over 100 trips. It isn't much a question of price; it is the question of price per trip.

The CHAIRMAN. What variation is there in the price charged by these 10 firms which you say are engaged in the manufacturing of milk bottles?

Mr. LEVIS. Where we have tested, sir, we run about 58 trips per bottle and the Department of Agriculture's record is 34.

The CHAIRMAN. You didn't understand my question. I say, what difference, if any, is there in the price charged by these 10 manufacturing companies for the bottles which they sell?

Mr. LEVIS. It will range 25 and 30 cents a gross difference.

The CHAIRMAN. I don't understand your answer.

Mr. LEVIS. I am sorry, sir.

The CHAIRMAN. I have evidently not made my question plain to you. Is there any variation in the price charged by these 10 companies for the milk bottles which are produced by them?

Mr. LEVIS. Yes, sir; the variation in price is as much as from 25 or 35 cents per gross.

The CHAIRMAN. I see. How many companies charge the low price and how many companies charge the high price?

Mr. LEVIS. It depends, sir, upon how bad they need the business and where it is.

The CHAIRMAN. So your answer is that there is competition among these firms as to price.

Mr. LEVIS. I believe so and hope so.

Mr. COX. I'd like to ask one or two questions along that line, if I may, of Mr. Levis before any one else resumes a different subject.

Senator BORAH. I'd like to know just how definite your knowledge is as to there being competition in the sale of these milk bottles among these 10 men, or let me ask first—is it within the power of the Empire Co. to enforce one price among them all?

Mr. LEVIS. No, sir.

Senator BORAH. Why not, if it wouldn't issue a license except upon such terms as it sees fit?

Mr. LEVIS. It never has done it, sir. They may have the legal right, but as I testified, and I think they do, at no time has there ever been coupled with what right there may have been any price-control factors.

Senator BORAH. That may be true, but what I am asking is, is it not within the power of the Empire Co. owning all these patents, and all others dealing with the subject, to enforce a price if they see fit to do it, among all? Mr. Smith testified that they would pass upon the question of whether a man's field of business was sufficient to justify the issuing of a license. Wouldn't the question of price, and so forth, enter into that?

Mr. LEVIS. Not to licenses granted without that restriction, sir. I imagine that license may remain in existence and not be subject to change.

Senator BORAH. I understand that, but suppose a man comes and asks for a license from the Empire Co. and says he wants to go into business, and the Empire Co. passes upon the question of whether he should have the license. It may say yes or no, and for any reason in the world that suits it. It may say, "We are not granting license except upon the understanding or the agreement that such and such a price be charged."

Mr. LEVIS. It may, sir, but it never has.

Senator BORAH. Yes; I know.

Mr. LEVIS. The other situation, sir, that comes into the equation is one of the competitive container. If we were to have a high price, a paper bottle might take all of the business and then we would deprive ourselves of our market through our error.

Senator BORAH. I understand that, and, of course, that would interest you, but I am saying now, have they not the power, if they see fit, having only 10 customers in the United States, or 10 firms in the United States carrying on the business, to say to all these people who get a license from them, "We are granting licenses only on the understanding that you charge a certain price."

"We must do that," as Mr. Smith says, "in order to look properly after our licensees."

Mr. LEVIS. It is not my opinion that there is any legal right they have, and even if there were, they have never exercised it.

Mr. Cox. May I ask a couple of questions along the line that Senator Borah has been pursuing as to milk-bottle prices, Mr. Levis. Let's see, you and Thatcher together manufacture about 70 percent of the milk bottles in the United States, don't you? I am including your Pacific coast company.

Mr. LEVIS. Yes, sir.

Mr. Cox. Now, Mr. Levis, you wouldn't seriously dispute it, would you, if I suggested to you, if we charted the prices charged by your company and Thatcher, it would show that all the changes in the price lists over a period of time occurred for both companies in the same month and the same year?

Mr. LEVIS. No. If you want to embark into the theory of price policy, which is quite a large subject, I will be just tickled to death.

Mr. Cox. I wouldn't want to go too deep.

Mr. LEVIS. But Thatcher sets a price on milk bottles and Ball does on certain lines and we do on certain lines and Hazel do on certain lines. We can't ask any more than they ask as leaders in the line, and we are not going to take any less because we think our goods are as good as theirs.

Senator BORAH. That is just the way they fix the price.

Mr. ARNOLD. But you are interested, or have been, or at least there has been a good correspondence to the effect that you are interested, in what you might call stabilization of the industry.

Mr. LEVIS. Mr. Arnold, the correspondence is working papers with me. I am not interested in anything that has happened.

Mr. ARNOLD. Letters to your uncle—those ideas have at least passed through your mind, and letters to your uncle and your father.

Mr. LEVIS. I wrote that letter to my uncle in 1931, or someone in 1931, and someone else in '32.

Mr. ARNOLD. And you have refused licenses—I mean there is some correspondence to that effect.

Mr. LEVIS. Now every crackpot that writes us and wants to let us believe that he has a million dollars to put in a glass factory and writes in longhand, we are not going to send a man to see him. I mean you have got to terminate the thing. If I ran a law office I wouldn't take as my client every guy that came in the door.

Mr. ARNOLD. But the correspondence doesn't indicate that they were turned down because of lack of financial ability. As I heard it, it indicated that you just weren't granting licenses at all.

Mr. LEVIS. We gave that as words to express the desire to no longer correspond on something we thought wouldn't materialize.

Mr. ARNOLD. I see, but at least there is this in the picture. The correspondence which we have introduced is very much at variance with your now stated policy, isn't it? It may be wrong, but that is the fact. Isn't that true?

Mr. LEVIS. I could only say that, sir, and perjure myself. My record was clear when I came here this morning that I qualified that I had a right to have trading talk and I had a right to have my mind made up on something and I had a right to change my mind. Now I have done that.

Mr. ARNOLD. All I am bringing out now is that at various times there is a good deal of evidence of a good deal of interest in price stabilization policies, in keeping patents exclusively for yourselves, in

joining up with other companies in bringing patent infringement suits—that all appears at different times as part of what the company has done, and that your present policy is a matter which can be very easily changed. It is entirely within your power either to follow your present statement or the line taken by that correspondence. Isn't that true?

Mr. LEVIS. Oh, sir, no more than anyone else enjoys that right, politically or otherwise. If I have done something wrong—

Mr. ARNOLD (interposing). I wasn't suggesting you had done anything wrong. The purpose of my question was directed to only one thing, and that is this: The anti-trust division is interested in the power to limit competition. This is not an investigation of any unethical or immoral conduct on your part. It is an investigation of the extent of your power, and it had occurred to me that there was a good deal of evidence in here that from time to time you had exercised that power.

Now specifically, why were you interested in joining up with the Hartford-Empire and taking half of the burden on infringement suits, designed, frankly, to stop other people from manufacturing glass?

Mr. LEVIS. Mr. Williams explained this morning why we were interested, and I explained yesterday and this morning that I had no interest, and if they would cut off the connecting link between the two at the date October 1, 1935, the chart would be right, because since then we sold out. We have no interest in it.

Mr. Cox. You still have a cross-licensing agreement there, though.

Mr. LEVIS. No more than would put us out on those other lines. They have one too, haven't they?

Mr. Cox. I am just sensitive about my chart.

Mr. LEVIS. I am not critical of your chart, but in 1935, that is 3 years ago, Mr. Arnold, we discontinued contributing to those things, we discontinued taking it, we sold our patents for two and a half million dollars worth of money to be paid over a period of two and a half years. That is what I had always desired to do. I explained it at length. The only point I want to make, you people have been awfully nice to us and awfully fair, and your boys have been in our office for 12 or 13 weeks, and we have turned over to them and we have cooperated in every way we could and they have been nice and fair with us. If out of that 12 weeks' investigation there is nothing more serious than I have been confronted with today, I go away happy.

Mr. ARNOLD. I think you are taking a very erroneous assumption on the basis of which this question was asked. There is certainly nothing serious developed involving you personally in any violation of the law. That is perfectly true. That wasn't the purpose that we sent the people around there. But it does seem to me—and I wonder if it doesn't seem to you—that there is a power over the glass business developed through this holding of patents, through the power to refuse licenses, through the desire to stabilize the industry and through (I don't use the word in an offensive sense) the ganging up of these companies on infringement suits, which does not create what a person would call a competitive situation. Would you agree with that?

Mr. LEVIS. Yes. If these fellows would tell you the facts, Mr. Arnold, they think I am the greatest opponent to that power that has come into the industry.

Mr. ARNOLD. You may be an opponent of the power; your testimony seems to indicate it, but the power is there.

Mr. LEVIS. You traced it for 25 years and I thought you disposed of that thing. You finally did it. I am not here to pass—

Mr. ARNOLD (interposing). We might be on the same side, Mr. Levis.

Mr. LEVIS. I think we are, sir.

Mr. ARNOLD. And you would like to give up that power.

Mr. LEVIS. I have given it up—in 1935, sir.

Mr. ARNOLD. And as a matter of social policy do you think it would be a good thing if the Hartford-Empire would do so?

Mr. LEVIS. I can't answer that.

Mr. ARNOLD. You can answer as a matter of social policy for the industry.

Mr. LEVIS. Is that fair, sir?

The CHAIRMAN. I think you have answered; and supplementing what Mr. Arnold has said, I think it ought to be made clear to you and to all other persons who have been summoned here as witnesses that the purpose of the committee was to be just what these representatives of the Department of Justice have been to your company, according to your statement—fair, seeking to understand a condition. There is no question of moral turpitude involved here, and I hope, I really hope, that you never entertained the belief that there was, because this committee is merely trying to discover, as Mr. Arnold said and as Senator Borah said, whether or not there exists, as a result of the patent law, the power to control prices of glassware in this country. Now that is all we are interested in, and we have not sought at any time, and I am sure Mr. Cox will agree, to fasten upon you any sense of guilt.

Mr. LEVIS. No, sir; you have been very fair, and I only hope that giving you the benefit of my experience has been what you want.

The CHAIRMAN. I think it has been very helpful, speaking for myself, and I am sure the other members of the committee feel likewise.

Mr. ARNOLD. With respect to my question, I was in the hope that I could get your opinion on the glass industry, even the Hartford-Empire situation. If you have no opinion, that is sufficient. You have met pay rolls and I haven't.

Senator KING. I would like to ask whether or not the output of glass containers has increased from year to year during the past 15 years or 20 years.

Mr. LEVIS. Very much, sir.

Senator KING. What is the output now, contrasted with the output 10 years ago or 5 years ago or 2 years ago?

Mr. LEVIS. I don't know if I could quote that. I think I have a schedule here that would show that. I don't find it right now, but production, as I recall it, has almost doubled in the last 10 years, somewhat due to the return of beer and whisky.

Senator KING. It has considerably more than doubled, has it not, in the past 10 years—the output?

Mr. LEVIS. Yes, sir.

This curve shows it, sir. I think I can read from it.

Senator KING. I thought I had the figures in my file.

Mr. LEVIS. In 1928 it was roughly 30,000,000 gross. It went up to about 32,000,000 gross in '35; it went down as low as 25,000,000 gross in 1933, and last year it was up to about 47,000,000.

Senator KING. Is that the highest output?

Mr. LEVIS. Yes, sir; ever in its history.

Senator KING. Forty-seven million gross. Would that embrace all—

Mr. LEVIS (interposing). That is all of the capacity east of the Rocky Mountains. The west coast follows almost parallel to it, sir.

Senator KING. Then that does not comprise all of the output in the United States, if I understand you.

Mr. LEVIS. We can add them together. I have a west coast figure here also, the peak of which was roughly 3,500,000 gross.

Senator KING. Then that would be over 51,000,000 gross. With the increase in the output, what do you say as to the price, whether it has increased or been reduced?

Mr. LEVIS. It has decreased, sir.

Senator KING. What percent of decrease in the price of the commodity, from year to year?

Mr. LEVIS. The price has gone down from 1925 from around about \$3.75 a gross to a low of about \$2.80 a gross in 1933. In 1935 it returned roughly to \$3 a gross, and is now around about \$2.90. I am reading this chart roughly, sir. There are things that influence price, such as the packages and closures, caps, and types of packing. In other words, a beer bottle used to be sold in bulk, piled loose in a car. Today it is sold in a corrugated box. A whisky bottle takes a more expensive package than a ketchup bottle. This is the price of the glass in its package, ready to be delivered, so if you were to take out even that trend of the increased quantity or quality of merchandise that you give for the dollar, I think the price will even continue on that decline.

Senator KING. What proportion of the cost would you say should be attributed to those accessories?

Mr. LEVIS. About 12½ percent in packages—about the same as the freight.

Senator KING. So you would deduct 12½ percent from the gross price now in order to reach the level of the price of the glassware?

Mr. LEVIS. Talking about naked bottles packed.

Senator KING. You stated there was competition between the 10 producers. Was that constant, that competition? Was there weekly or yearly competition?

Mr. LEVIS. Yes, sir; I think, sir, that we are in competition with each other and in competition with other containers.

Senator KING. What other containers are in competition with yours?

Mr. LEVIS. The tin can, paper milk bottle, and plastic jars.

Senator KING. Have they entered the field to any great extent?

Mr. LEVIS. The beer can did, sir. The paper milk bottle seems to have made great strides. I know I used to buy tomato juice in glass, and now it comes in a can. That is why we went into the can

business. We thought maybe some fellow might change and we could get him anyway.

Mr. Cox. Since Senator King has asked about price trends, I would like to ask you if it isn't a fact that the list price of milk bottles in the industry, at least as between you and the Thatcher Co., remained constant from November 1924, to January 1931, and again from November 1933, to April 1938?

Mr. LEVIS. I couldn't answer that specifically, but I think maybe Mr. Martin could. I didn't come prepared for that.

Mr. Cox. I realize you didn't.

Representative REECE. May I ask Mr. Cox if you expect to develop the question with reference to the right of a concern to license a patent; that is, the intangible patent, as compared to his right to license a tangible article which may have embodied in it a patent? Do you plan to develop those two questions? It seems to me, as I indicated in one of my questions the other day, that there are two questions involved; that is, even under our present laws, or maybe under any policy that Congress might consider adopting, there is one dealing with the right of a concern to license the patent itself, and another dealing with a concern's right to lease an article, a machine, a tangible article, as distinguished from the intangible right; the patent itself.

Mr. Cox. I think the best answer I can make to your question, sir, would be that we plan to show, and I think have shown, if I understand your distinct question, that both practices have been followed in this industry. That is, they have a leasing of machines and a granting of a license to use a machine, and you also have the exchange of patent rights as such, quite apart from any object. I don't know that we are going to develop it any more than to show that those two practices exist so far as the presentation of evidence is concerned. I think it may be a matter of comment in our report. I wouldn't want you to believe that we were going to have any witnesses to testify particularly as to that distinction.

The CHAIRMAN. Are there any other questions? If not, the witnesses are excused. We thank you very much.

Mr. Cox. I think, perhaps, since there was so much talk about these contracts, that, without having them printed, they should be inserted as original exhibits and identified.

The CHAIRMAN. To which contracts do you refer?

Mr. Cox. All contracts between 1924 up to 1935 between Owens-Illinois and Hartford-Empire.

The CHAIRMAN. They may be admitted.

(The contracts referred to were marked "Exhibits Nos. 135 to 141," inclusive, and are on file with the committee.)

Senator KING. Would you care to express any opinion as to whether or not it would be advantageous to the glass industry, particularly to the milk bottle part of the glass industry, if there were no patent system at all? That is to say, any person could manufacture glassware without licenses and without patents.

Mr. LEVIS. I have a lot of theories on that. It doesn't only involve that, but it involves our opinions on many phases of the patent situation which Mr. Borkin and his associates asked me to talk to them about later. I will be willing to do it now if they want it done now.

Senator KING. If you have talked to them at their solicitation I have no doubt that later the matter will be developed. I shall not press the question now.

Mr. COX. We have no objection; we would be glad to have Mr. Levis tell us now what he feels about it.

Mr. LEVIS. I more or less prepared for the situation in connection with my discussions on the theories of cross-licensing. I feel that when a concern has become large and it has its business established, and it has an organization that is capable of carrying on its developments, that that concern then naturally prefers to have compulsory licensing. It is a means that without an expense to them they can acquire a right to do certain things without being excluded by these small interferences; or, in other words, if we can go ahead and develop the theory of the building of our machines, we having arrived and been established and having been capable of affording to have a development in engineering and design organization, we would much prefer that we could ask for a compulsory license on anything that interferes with the progress of our development.

On the other hand, we believe that is—what shall we call it—an incentive for genius, an incentive for capital to invest in the ideas of genius, that any infant industry or any new idea should be given the benefits of a patent protection, and we believe that those items are not inconsistent if the legislation is such that it requires a shorter space of time in which a patent of one type can be subject to compulsory licensing or subject to the protection of genius than one that is purchased, say, in order to build up a field.

I think that states it fairly accurately, Mr. Borkin, as I have stated to you.

Mr. BORKIN. That is right.

Senator KING. Are you acquainted with the report of the Science Advisory Board of the patent system, appointed by the Secretary of Commerce a number of years ago?¹

Mr. LEVIS. No, sir; I am not.

Senator KING. In which they discussed some of these questions about compulsory licensing?

Mr. LEVIS. No, sir; I am not, but I wish I were; I would like to know more about it.

Senator KING. I shall later draw the attention of the committee to it and perhaps put some extracts of it in the record. I will not burden the record today.

The CHAIRMAN. Thank you very much, Mr. Levis. We have profited very much from your testimony.

(The witness was excused.)

Mr. COX. If I could have 5 minutes adjournment I can bring another witness.

The CHAIRMAN. The committee will stand in recess for 5 minutes. (Fifteen-minute recess.)

The CHAIRMAN. The committee will come to order, please. Mr. Cox, are you now ready to proceed?

Mr. COX. I am.

The CHAIRMAN. Will you call your next witness.

Mr. COX. The next witness is Mr. McNash. Mr. McClure, will you come up also.

¹ Subsequently entered in record as "Exhibit No. 206," see Hearings, Part III, appendix.

The CHAIRMAN. Do you and each of you solemnly swear that the testimony you are about to give in this proceeding will be the truth, the whole truth, and nothing but the truth, so help you God?

Mr. McNASH. I do.

Mr. McClure. I do.

TESTIMONY OF J. H. McNASH, PRESIDENT, HAZEL-ATLAS GLASS CO., WHEELING, W. VA.; AND TESTIMONY OF WALTER H. McCLURE, VICE PRESIDENT AND GENERAL SALES MANAGER, HAZEL-ATLAS GLASS CO., WHEELING, W. VA.

Mr. Cox. Will each of you in turn give the reporter your name and address, and your occupation?

Mr. McNASH. J. H. McNash, Wheeling, W. Va., president, Hazel-Atlas Glass Co.

Mr. McClure. Walter H. McClure, vice president and general sales manager, Hazel-Atlas Glass Co., Wheeling.

Mr. Cox. Mr. McNash, the Hazel-Atlas Co. is a company engaged in manufacturing glass containers, is that right?

Mr. McNASH. Yes.

Mr. Cox. And it is a large manufacturer, in fact it is about the second largest.

Mr. McNASH. The second in size, that is right.

Mr. Cox. Can you give us an approximate percentage of all glass containers produced by your company?

Mr. McNASH. Around 18 percent.

LITIGATION AND LICENSING

Mr. Cox. How long has the Hazel-Atlas Co. been in the business?

Mr. McNASH. Probably 50 years—predecessor and the present corporation.

Mr. Cox. And you at the present time are licensees of the Hartford-Empire Co., is that right?

Mr. McNASH. That is right.

Mr. Cox. You were at one time, and still are, I understand, a licensee of the Owens-Illinois Co., is that right?

Mr. McNASH. That is right.

Mr. Cox. Your first license was from the old Owens Bottle Co. in 1909.

Mr. McNASH. That is right.

Mr. Cox. And that license was received in consideration for the exchange of one-third of your capital stock, is that correct?

Mr. McNASH. Correct, \$500,000 in our stock, to be exact.

Mr. Cox. Thereafter that stock was repurchased, was it not?

Mr. McNASH. It was.

Mr. Cox. When was that?

Mr. McNASH. In 1926, I believe. We paid approximately \$3,600,000 for that stock.

Mr. Cox. Now, when did you first become a licensee of Hartford-Empire?

Mr. McNASH. 1932.

Mr. Cox. Prior to that time, had you been engaged in litigation with Hartford-Empire with respect to patents?

Mr. McNASH. On a wholesale basis; yes.

Mr. Cox. How many of those suits were there, can you tell us?

Mr. McNASH. There was a suit against the Kearns-Gorsuch Bottle Co., located at Zanesville, Ohio, a subsidiary of our company. We owned all the shares. I think there were four or five patents involved in that suit. Then the Hazel-Atlas Glass Co. was sued under Peiler patent.

Mr. Cox. That is the one we were speaking of as the heated hood patent?

Mr. McNASH. No; it was the famous stuffing patent. And I think at a later time than that a suit was entered against the Hazel-Atlas Glass Co. in Wheeling, W. Va. That suit was never tried.

Mr. Cox. Can you tell us approximately how much money this litigation cost your company?

Mr. McNASH. We have a very good record, I believe, of the legal expenses involved, but we do not have the record of the expense involved in the time of people on our staff taken from their jobs, their various positions in the organization. It would be almost impossible to calculate that part of the expense. We have no record of that.

Mr. Cox. Can you tell us what the legal expense was?

Mr. McNASH. I believe it ran somewhere from 50 to 150 thousand dollars a year.

Mr. Cox. For as long as this litigation lasted?

Mr. McNASH. Yes.

Mr. Cox. And that again was a suit against the Kearns-Gorsuch Bottle Co.?

Mr. McNASH. Yes.

Mr. Cox. That was about 1925 or '6?

Mr. McNASH. I think about '26 or '27.

Mr. Cox. And continued until you accepted the license in '32?

Mr. McNASH. In 1932.

Mr. Cox. And that figure you gave us a little while ago doesn't include the expense which you referred to a moment ago as having been incurred by reason of the time and effort of your regularly employed officers?

Mr. McNASH. And the distraction from the manufacturing plant; that is correct.

Mr. Cox. Will you tell us, Mr. McNash, just briefly if you can why it was that you didn't take a license from Hartford-Empire before 1932?

Mr. McNASH. We were fairly well satisfied that the feeding device used by the Hazel-Atlas Glass Co. was a mechanism entirely of our own development. We saw no reason why someone should come in and attempt to control our use of that device.

Mr. Cox. But in 1932 you changed your mind; is that correct?

Mr. McNASH. The circuit court of appeals for Philadelphia district changed our mind.

Mr. Cox. After that decision you decided there wasn't any point in going on with this?

Mr. McNASH. No; we were going on.

Mr. Cox. You were going to petition for certiorari through the court.

Mr. McNASH. Correct.

Mr. Cox. Tell us why, then, you did take a license in 1932 from Hartford-Empire.

Mr. McNASH. The Hartford-Empire Co. approached us in connection with taking a license and eventually under such conditions that I think we would have been foolish to refuse.

Mr. Cox. What were these conditions that you think it would have been foolish to refuse?

Mr. McNASH. When these negotiations began, our view was a willingness to settle, paying Hartford annually about the amount of our legal expenses. Those negotiations were handled by me and that was quite clear in my mind that was all we could do.

Mr. Cox. You thought you might as well pay it to them as to the lawyers.

Mr. McNASH. That is correct, to be free from the troubles incident to lawsuits.

Senator KING. I suppose the fact that the court of appeals decided against you was one of the factors that influenced you to seek a compromise.

Mr. Cox. I was asking what conditions you thought it would be foolish for you to refuse a license from Hartford.

Mr. McNASH. We were willing to pay the Hartford-Empire Co. this amount that we were spending for legal services, to free ourselves from the troubles incident to these various suits.

Senator KING. May I ask, do you have any suits against persons for alleged infringement of your patents?

Mr. McNASH. Not to my knowledge. I am sure we did not have.

Senator KING. The company, then, never brought suits for alleged infringements of your patents?

Mr. Cox. You brought suit back in 1923 with Owens against the J. T. and A. Hamilton Co.

Mr. McNASH. Did it ever amount to very much?

Senator KING. I didn't ask the amount. I asked if you brought any suits.

Mr. McNASH. Evidently the Hazel-Atlas did in 1923. I don't think of any important one.

Mr. Cox. They were joint plaintiffs in suit with Owens-Illinois Co.

Mr. McNASH. But I am on the subject now of why I took the license.

Mr. Cox. That is right; you were still there.

Mr. McNASH. We were willing to pay Hartford that amount. In addition to that, relieving us of this embarrassing suit situation, the idea was that we would have call on Hartford development if we wanted it. As a matter of fact, these negotiations kept changing from time to time and day to day, and it was apparent that Hartford-Empire could not make such an arrangement with us. Before we got very far it was necessary for the Hazel-Atlas Glass Co. to agree to pay damages, because according to their judgment we were in the position all these years of having used their device and paid nothing for the use.

Mr. Cox. How many years did the claim that the Hartford people make cover?

Mr. McNASH. Of course, these suits were brought at different times and the suit against Kearns-Gorsuch didn't necessarily pile up the damage against Hazel-Atlas. The Hazel damages piled up after the

suit was filed in Pittsburgh, or the notice of that infringement. I don't know what the total amounted to: I would say, in a general way, \$2,000,000 or \$2,500,000, or thereabouts.

Mr. Cox. That was the contingent liability which you faced if you lost the contest.

Mr. McNASH. That is right.

Mr. Cox. Go on now.

Mr. McNASH. So we said that if other things were reasonable we would agree to pay damages, to cut that out. In addition to that, we insisted that our position in this industry be no different than the position of the then Owens-Illinois Glass Co.

Mr. Cox. Why did you insist on that?

Mr. McNASH. We were a licensee of the Owens-Illinois Glass Co., for all their development.

Mr. Cox. That was under the 1904 agreement?

Mr. McNASH. 1908 or 1909; for all their development. Of course, the Owens contention was that development applied to suction only. Our view was broader than that. However, that point never has been litigated. Maybe it is just as well it hasn't, but it hasn't been litigated.

Mr. Cox. You haven't had to pay lawyers for that?

Mr. McNASH. Not on that point. At one time in the relation between Owens and Hazel as the result of that 1909 license, Mr. M. J. Owens arranged with our Mr. J. C. Brady for us to turn over to Owens the title to our Brookfield patent. The understanding was that the Owens Bottle Co.—then the Owens Bottle Co.—would sue the Hartford-Empire Co. They did sue, but under the Lott patent, not Brookfield. Before that suit had gotten very far, it was apparent that negotiations were on between the Owens Bottle Co. and the Hartford-Empire Co., and you heard Mr. Williams say that among the patents in the cross-licensing of Owens Bottle and Hartford-Empire was this Brookfield patent they had gotten from us. As I said a while ago, we also contended we were entitled to all of the development. Our working arrangement with the Owens Bottle Co. as a result of the 1909 agreement and the fact that they had 500,000 shares of our stock, was necessarily a very close working arrangement, so we felt fully justified in insisting that if this suit in question was to be compromised, it had to be compromised on the basis that at least we were in as good a competitive position as the Owens-Illinois Glass Co., and that eventually was worked out.

Mr. Cox. Now tell us, briefly, if you can, what the provisions of that settlement agreement were. Perhaps it would be quicker if we did it this way. Would it be accurate to say under that agreement, you agreed to pay the regular royalty rate to Hartford for the machines which you were using then?

Mr. McNASH. That is right.

Mr. Cox. Although those were not machines which you got from Hartford-Empire in the first instance?

Mr. McNASH. That is correct.

Mr. Cox. Not machines that they had had built?

Mr. McNASH. That is correct. We are using today, I think, one Hartford-Empire feeder.

Mr. Cox. And yet you are paying royalty to Hartford on all your machines.

Mr. McNASH. That is right.

Mr. Cox. And in return for that agreement on your part to pay royalty at regular rate, Hartford-Empire was to pay you one-third of its divisible income. Is that correct?

Mr. McNASH. That is correct.

Mr. Cox. And that divisible income was the same kind of income that was defined this morning; that is, it was income from royalties, profit on manufacturing, license fees over the cost.

Mr. McNASH. You have it better than I have.

Mr. Cox. Those were the items. In other words, roughly speaking, it was Hartford's income from patents and patent rights, including infringement suits, and deduction was to be made from that, and you were to get one-third of that.

Mr. McNASH. That is right.

Mr. Cox. Is that contract still in effect?

Mr. McNASH. Yes, sir.

Mr. Cox. How long does it run?

Mr. McNASH. About 1945.

Mr. Cox. You have prepared and sent to us some figures.

Mr. McNASH. Before we get onto that, I think this contract thing probably should be talked about a little more. I don't know that our relation with Owens had any particular effect on Hartford-Empire. I think the thing that disturbed Hartford-Empire was we were going to make every effort to get to the Supreme Court of the United States. I think in addition to that, they fully realized the resourcefulness of our organization and experience in the practical application of feeding devices of all kinds.

Mr. Cox. You were a large company?

Mr. McNASH. A large company.

Mr. Cox. You were in a position, if you cared to, to fight on?

Mr. McNASH. That is right. And we had that experience. That experience might have been very attractive to Hartford-Empire Co. In addition to that, we had a fairly large array of patents. Just what they were worth, I don't know. We never utilized them to any extent in establishing them generally.

Mr. Cox. If you had been a smaller company with less resources, the story would have been quite different, wouldn't it?

Mr. McNASH. I don't know as to that. But I do believe, though, that the Hartford-Empire Co. had a very large and great respect for our ability to apply these things. I might add, too, that we had, after this Philadelphia decision was against us, made quite a few changes in our feeding device. We made quite a lot of progress along that line, I think, in the direction of probably having those patents—rather, those feeders—come outside the patent involved in the *Pittsburgh case*. That is only our view. I have never wished to test it. It might have meant other lawsuits had that continued; it probably would have. But we did surprise ourselves in what we were able to accomplish in the way of changing our feeders to come outside the scope of that Pittsburgh patent. I have every reason to believe that Hartford was aware of just what we were doing in that respect.

Mr. Cox. Of course, if you had done that you would have faced some more litigation.

Mr. McNASH. Lawsuits; that is right.

The CHAIRMAN. Mr. McNash, I understood you to testify that in conducting your negotiations with the Hartford-Empire for the settlement of this litigation, you intended that your company should be put in at least as good a position as that occupied by the Owens-Illinois Co.

Mr. McNASH. That is right.

The CHAIRMAN. Now what was that position as you saw it?

Mr. McNASH. The position that they secured in their arrangement with the Hartford-Empire as of 1924.

The CHAIRMAN. And just what was that?

Mr. McNASH. They were contributing to the patent experience of Hartford-Empire and also the engineering experience of Hartford-Empire, in exchange for half the so-called divisible income of Hartford.

The CHAIRMAN. And what position were you fearful of being put into if you had not insisted upon this equal treatment?

Mr. McNASH. We either had to beat Hartford-Empire's contention in the courts or pay royalty to the extent of approximately eight or nine hundred thousand dollars a year, maybe a million dollars a year that the Owens would not be paying.

Mr. Cox. It placed you at a competitive disadvantage against Owens.

The CHAIRMAN. And the final result was that although you use only one of the Hartford-Empire machines, and all of the other machines which you use are those which you developed yourself but the patent on which was in litigation, you now pay to the Hartford-Empire royalties upon all of these machines and receive in return one-third of the divisible income of the Hartford Co.

Mr. McNASH. That is correct.

Representative SUMNERS. Mr. McNash, you said awhile ago that during this period of uncertainty and of negotiation you had made some improvements in order to bring, as you hoped, your processes outside of the patents of the other concern. Were they patented or were patents applied for on these improvements?

Mr. McNASH. No; we have never been very patent-conscious.

Senador KING. Your company did have patents, did it not?

Mr. McNASH. Oh, yes.

Senator KING. Were they patents which were the invention of representatives of your company as predecessors or members of the corporation?

Mr. McNASH. That is right; employees of the corporation.

Senator KING. And how long had your company been in existence when this litigation commenced, based upon patents which you had taken out?

Mr. McNASH. You mean the company in existence or the patents?

Senator KING. The patents.

Mr. McNASH. They had been in existence quite some time.

Senator KING. And was it the contention of the Hartford-Empire that your patents infringed patents which they owned?

Mr. McNASH. Patents and the devices we were using infringed theirs.

Senator KING. You contended there was no infringement.

Mr. McNASH. That is right.

Senator KING. And litigation then followed for several years.

Mr. McNASH. Quite some years.

Senator KING. At considerable cost to your company, and finally the circuit court of appeals decided you had infringed their patents.

Mr. McNASH. That is right.

Senator KING. And then this compromise was effected to which you have referred.

Mr. McNASH. That is right.

Senator KING. Did the action of the Owens Co. which had a \$500,000 interest or stock in your corporation have any influence in effecting the compromise?

Mr. McNASH. None, because they owned no stock in our company at that time. The Owens Bottle Co. holdings in our company were repurchased by us, I think, in 1926.

Senator KING. So at the time the compromise settlement was made, the Owens Co. did have no interest whatever in your company.

Mr. McNASH. That is right, and have not had since, neither the Owens-Illinois or Owens Bottle.

Senator KING. What circuit court of appeals decided adversely to you?

Mr. McNASH. The one in Philadelphia.

Mr. Cox. The third circuit opinion, written by Judge Buffington.

Senator KING. Have you the date?

Mr. Cox. Just a moment and I will give you the citation. It is in Fifty-ninth Federal Reports (2d), page 399.

Mr. McNASH. would it be accurate to say after this contract was made, the result was that the divisible income of Hartford was split in three ways, one-third to Hartford, one-third to Owens, and one-third to you, instead of having been split two ways as before?

Mr. McNASH. That is right.

Senator KING. Were you to be the beneficiary of any patents which the Hartford Co. might acquire after that settlement? If they acquired new patents which contributed to the development of the industry, were you to have any benefits?

Mr. McNASH. Yes; that is right.

Senator KING. So any patents that they have acquired or may acquire, your corporation becomes a beneficiary?

Mr. McNASH. That is right, during the life of the contract.

The CHAIRMAN. What is the life of the contract?

Mr. McNASH. Until 1945.

Representative SUMNERS. What is the divisible income?

Mr. Cox. The divisible income, Congressman, in a sentence, is all of the income of Hartford-Empire from patents and patent rights, less a deduction which in the beginning was \$600,000, and from 1932 to 1935, I think, was \$850,000. Is that right?

Mr. McNASH. I think so.

The CHAIRMAN. Was that the overhead?

Mr. Cox. I don't know. We have tried to develop that. I don't know what the \$600,000 was, or the \$850,000. That is just a thing that was deducted.

Now, while this contest was going on between you and Hartford-Empire, Mr. McNash, it was true, wasn't it, that there were a number of smaller glass companies who were also charged with infringement

of the Hartford patents, who were rather waiting to see what the outcome of the battle was going to be?

Mr. McNASH. That is right.

Mr. Cox. So that if before the decision of the court of the third circuit we have just referred to, a chart like that had been drawn, there would have been a far larger number of companies on the extreme right which would not have been licensees.

The CHAIRMAN. You are now referring to "Exhibit No. 113."¹

Mr. Cox. That is right, "Exhibit No. 113." Have you seen the chart?

Mr. McNASH. I see it in front of me.

Mr. Cox. And after you took a license from Hartford-Empire, it is true, isn't it, that a substantial number of those smaller companies also took licenses?

Mr. McNASH. That is true.

Mr. Cox. Did you at any time take any part in attempting to persuade any of those companies to take a license in the Hartford-Empire, Mr. McNash?

Mr. McNASH. I did not.

Mr. Cox. You didn't talk to them about it or advise them?

Mr. McNASH. I did not.

Mr. Cox. You felt that was none of your affair?

Mr. McNASH. None of my affair.

Mr. Cox. You didn't ever, in the case of the Brockway Glass Co., attempt to persuade them?

Mr. McNASH. I don't think the Brockway people ever talked to me.

Mr. Cox. Would you make the same answer with respect to the Tygart Valley Glass Co.?

Mr. McNASH. The Tygart Valley Glass Co. never did discuss this question with me. Of course, their plant being in the same town in which we have three plants, their manager, I think, occasionally did talk to our general factories manager located there, but I am satisfied that our general factories manager did not advise the Tygart Valley Glass Co. what they should or should not do.

Mr. Cox. I think I will ask you again about these figures which you gave us which show the royalties which you paid to Hartford between 1932 and date, payments received by you from Hartford. Will you look at those?

Mr. Cox. We will just use the letter, then, if that is satisfactory.

Mr. McNASH. Right.

Mr. Cox. This letter shows that you have paid to Hartford-Empire, from 1932 to the end of the first 9 months of 1938, \$5,770,140.97; that Hartford-Empire has paid you \$6,528,660.94.

Mr. McNASH. That is correct.

Mr. Cox. So that you have a net gain on that transaction of about a million dollars.

Mr. McNASH. Well, to be exact, it is \$750,000.

Mr. Cox. \$750,000. May I have this letter marked in evidence?

The CHAIRMAN. It may be so marked.

(Letter referred to was marked "Exhibit No. 142" and is included in the appendix on p. 787.)

¹ See appendix, p. 762.

Senator KING. You received more than you paid? Was that one-third of the divisible income?

Mr. McNASH. That is right.

Senator KING. I didn't quite understand, if you explained, why you got more.

Mr. McNASH. I think I should say that the contribution we received was greater than anyone had in mind that it might be at the time the 1932 license was negotiated with the Hartford-Empire Co. My own view of it was that it would cost us between \$100,000 and \$200,000 a year. The transaction turned out better than I thought it might.

Senator KING. You paid in royalties, if that is the proper term, to the Hartford Co., at \$5,000,000 plus, and received in return dividends of that divisible income, \$6,000,000 plus.

Mr. McNASH. Well, you can call it whatever you will. The fact is that we participated in the divisible income of the Hartford-Empire Co., in consideration for what they got from us.

Senator KING. I understand.

Mr. McNASH. It happened that that was greater than the amount of money we paid in.

Mr. Cox. Now, the effect of that agreement and of those payments has been, has it not, Mr. McNash, that you have been receiving a share of the royalty payments made by other licensees to Hartford-Empire?

Mr. McNASH. That being in the divisible income, we have.

Mr. Cox. And of course, since 1935 you are the only company which does share that income.

Mr. McNASH. The Owens having sold theirs for \$2,500,000.

Senator KING. Did you surrender to the Empire Co. in this transaction settlement your right, title, and interest to the patents which you claimed?

Mr. McNASH. That's right.

Senator KING. So you claim to have sold patents which had value in this transaction?

Mr. McNASH. And then this accumulation of years of experience in the application of these devices.

Mr. Cox. Was it your opinion, Mr. McNash, that the result of that situation has been to give you any competitive advantage as against licensees who do not share?

Mr. McNASH. Probably it has. I think that I should say this: I think I should say further in that connection, as was brought out today, the larger companies in the glass industry are able to take care of their own research and engineering problems, and do. The smaller concerns are not in that position. The Hartford-Empire Co. is rendering us no service. The Hartford-Empire Co. is rendering its smaller companies or licensees a real service.

If a licensee of the Hartford-Empire Co., as I understand it; using their devices, has mechanical difficulties or glass difficulties, the Hartford-Empire Co. have a well qualified staff to assist in the solution of those difficulties. They are available at all times to the licensees. We don't call on that service. As a matter of fact, speaking for the Hazel-Atlas Glass Co. alone, we are constantly building up an experience that is available to the Hartford-Empire Co. to give to the licensees. Anything we do is at their service.

Mr. Cox. Are you speaking of the patents now?

Mr. McNASH. I am speaking of practical application of devices in operation.

Mr. Cox. That is more a matter of experience than patents or patent rights?

Mr. McNASH. That is right.

Mr. Cox. You don't get any of this service from Hartford-Empire, and you don't give it to anyone except Hartford-Empire?

Mr. McNASH. That's right.

Representative SUMNERS. On what basis is this service rendered? What compensation is given to the Hartford for this service?

Mr. McNASH. By its licenses. It is in the royalty the licensees pay.

Representative SUMNERS. Suppose a small concern wants the assistance of an engineer of the Hartford-Empire Co. to help them with some difficulties they have.

Mr. McNASH. I don't believe there is any charge made for it. It is in the royalty they pay.

Representative SUMNERS. You mean, they have paid for that?

Mr. McNASH. That is what they are really paying for. It is royalty, but they really are paying—

Representative SUMNERS (interposing). I've got it.

Now, another question, if you please. What did the patents and other things that you transferred to the Hartford-Empire Co. cost you? Have you any estimate of that?

Mr. McNASH. I don't think very much, because in most of the instances it was a matter of our own development.

Representative SUMNERS. Of course, you did have to make some compensation to the person who made them, but you never have estimated that?

Mr. McNASH. No.

Mr. Cox. You never made any income to speak of from those patents, from licensing them to others?

Mr. McNASH. We never have been in the licensing business. We are glass manufacturers.

Senator KING. You utilized those patents before the alleged infringement and before the settlement and you got the benefit of your own patents in the production of your machines in your factory, which production was sold to the general public.

Mr. McNASH. That is right.

Mr. Cox. Those patents, then, except for the use you made of the inventions which they covered for your own business, ultimately proved to be of value to you largely because of the bargaining position they gave you with the Hartford-Empire?

Mr. McNASH. That, plus our experience in the application of glass manufacturing devices.

Mr. Cox. And those two things, plus the fact that you had resources enough to continue the battle, are the things you testified a moment ago you thought led finally to the ultimate settlement with the Hartford-Empire Co.

Mr. McNASH. I think so.

Senator KING. I would like to ask one question, if I may. As a result of this agreement, did your corporation assume a larger field

in the production, a larger part of the field of production, and obtain any monopolistic advantages?

Mr. McNASH. I would say no. Understand, now, our manufacture of glass has increased, because the volume has increased in the industry.

Senator KING. Did you attempt, in view of that settlement, to restrict competition or join any other persons?

Mr. McNASH. Positively not.

Senator KING. And have you, during the life of your organization and particularly since the agreement to which you have referred, attempted unfair practices or engaged in the destruction of competition in the product of your factory or the product of others?

Mr. McNASH. We do not think we have.

Senator KING. Has there been reasonable competition, fierce or otherwise, between you and other manufacturers?

Mr. McNASH. There is reasonable competition in the industry.

Senator KING. Have the prices of your commodities been reduced during the past 15 or 20 years?

Mr. McNASH. They have. I have in mind especially in the wide mouth line, in which we are a large factor, used for the containing of food products. Our price level today is below the level in effect in 1913. In 1913 we were paying 12 to 14 cents an hour for common labor. Today we are paying 57½ cents for common labor. In spite of that, our price level today is below what it was in 1913.

Senator KING. Is it below what it was 10 years ago?

Mr. McNASH. Ten years ago would make it 1928. It is very much below 1928.

Senator KING. You are cheapening, then, your product, as the years go by.

Mr. McNASH. That is our constant aim in order to increase the use of glass.

Representative SUMNERS. How much, and to what percentage, has your labor volume, in proportion to productivity, decreased during those years?

Mr. McNASH. I cannot give you an exact figure in that respect. Of course, there has been a tremendous increase in the productivity per man.

Representative SUMNERS. By reason of improvement in machinery?

Mr. McNASH. That's right, but actually as a result of, especially for our company, the use of glass having increased so rapidly that today we are employing more people than we ever have in our history.

Representative SUMNERS. Can you give us an opinion as to the percentage of increase of productivity of the individual in that period from 1913 to now?

Mr. McNASH. No; I cannot. I can give you, I think, a very interesting instance.

Representative SUMNERS. If it won't take too much time.

Mr. McNASH. Mr. Levis testified today in connection with the Owens machine. I can subscribe to what he said in that connection with respect to the operation of an Owens machine. The Hazel-Atlas Co., as the record shows, had a license from 1909 to use Owens machines. We had seven furnaces equipped with Owens machines.

Senator KING. That is a suction machine?

Mr. McNASH. That is a suction machine. Even during that time, however, the preponderance of our operation was feeder. We never were very successful in the operation of an Owens machine in our wide-mouth field, and as a consequence of that, we eliminated its use. We began at the Hazel No. 2 plant in Washington taking one furnace at a time and converting it from Owens operation to feeder operation.

When that whole plant was changed the production had increased to the point that we had to shut down two other plants to keep a semblance of activity in this Hazel No. 2 plant. The fact of the matter is that we made on one furnace under extreme conditions almost as much glass as we made on four Owens furnaces in that plant.

Representative SUMNERS. Did you increase the number of persons operating that furnace?

Mr. McNASH. It takes more people to operate feeders than it does an Owens machine, but in our judgment there are other compensational advantages.

Representative SUMNERS. May I ask you one question? Did you build that Owens machine yourself or did somebody else build it and install it?

Mr. McNASH. We purchased those machines, I think, from the Kent Machine Co.

Representative SUMNERS. Is that machine company engaged in the business of making—

Mr. McNASH (interposing). I don't know where they are now.

Senator KING. In the aggregate, is your pay roll now larger than it was in 1913, 1914, or 1915, or any intervening period?

Mr. McNASH. Oh, decidedly.

Senator KING. Wages are higher and pay roll is larger, and the same or more employees than you had a few years ago?

Mr. McNASH. I said now. I should have said in 1937, when we were employing more people than ever in our history, because 1938 is not as good a year as 1937, and our operations are not as large.

Mr. Cox. I have about three questions I could ask Mr. McClure. I can dispense with him hereafter.

The CHAIRMAN. Proceed.

Mr. Cox. Mr. McClure, you are the vice president and sales manager of Hazel-Atlas?

Mr. McClure. Yes.

Mr. Cox. Do you have with you a copy of the reply you gave to us to a questionnaire we sent you with respect to this?

Mr. McClure. I have, but I left it at the hotel.

Mr. Cox. I will read to you some excerpts from your replies which you may recognize, because I want to ask you some questions about them. In answer to question No. 3 in that questionnaire you said, "Hazel-Atlas Glass Co. initiates the prices covering wide-mouthed container ware, and the Hazel-Atlas price list for ware of this class constitutes the recognized market price of the industry."

Is that to be understood as meaning that the tendency in the industry is, when you change your price for that class of ware, the other companies manufacturing that class of ware also change their prices, so that if your price goes up, their price goes up; if your price goes down, their price goes down?

Mr. McCLURE. Yes, sir.

Mr. McNASH. It doesn't vary that rapidly, though.

Mr. COX. That is generally true, is that right?

Mr. McCLURE. Generally speaking.

Mr. COX. You also say, "As to prices on proprietary and prescription ware we adopt the schedules of the Owens-Illinois Glass Co. and make their prices ours."

Mr. McCLURE. That is correct; yes, sir.

Mr. COX. I will quote again:

The same conditions as regards proprietary and prescription ware apply in connection with our liquor ware lists and our beer bottle lists. We are relatively small operators in these lines, and follow the market as established by the leaders in these branches of the industry.

Does that mean, as you state above, that you adopt the schedules of the Owens-Illinois Glass Co. for those lines of ware?

Mr. McCLURE. Yes; I might say we have only about three liquor accounts, and not many more than that in the beer business.

Mr. COX. I am quoting again from your reply. "As to fruit jars, for similar reasons we adopt the prices as published by the Ball Bros. Co. as our prices for fruit jars, jelly glasses, and fruit jar tops."

Mr. McCLURE. That is correct.

Mr. COX. "We initiate our own prices for automatically made pressed tumblers and tableware." That is not commonly regarded in the industry as a branch of the container manufactory.

Mr. McCLURE. No; but they are parallel lines, and you wanted information on all of them, containers and otherwise.

Mr. COX. "We initiate our own prices on opal ware for the cosmetic and drug trade." That is correct?

Mr. McCLURE. That is correct.

Mr. COX. You meant by that the tendency was for the other persons in the industry to follow your prices?

Mr. McCLURE. No, sir; we have only one competitor in that line, the Carr-Lowrey Co., in Baltimore.

Representative SUMNERS. To what degree, if any, is there competition in quality and style in this glassware? Has that gone into the record?

Mr. COX. I don't think there is much about that. I will ask some questions now about that. I will start first with the proprietary and prescription ware. You say you adopt the schedules of the Owens-Illinois Glass Co. as far as prices are concerned. Is there competition between the two companies as to the quality of that ware?

Mr. McCLURE. I don't know that there is; no.

Mr. COX. You think one piece of prescription ware is probably—

Mr. McCLURE (interposing). We make no prescription ware at all.

Mr. COX. What about the proprietary ware?

Mr. McCLURE. We haven't had a great line of business in that. We have molds and publish a price list and solicit the trade and have some few accounts of a rather small nature in that line. I am speaking now of narrow-neck ware. Of course, there are some drug store items that we make in rather large quantities, but they come under broad, wide-mouth schedules.

Mr. Cox. Would you say there was competition as to quality there?

Mr. McCLURE. There is some competition.

Mr. Cox. Each one trying to make a better jar, or whatever it may be, than the other manufacturer?

Mr. McCLURE. I assume so. We try to make the best we can.

Mr. Cox. Does the physical quality differ very much from manufacturer to manufacturer in your opinion?

Mr. McCLURE. The quality between manufacturers? Oh, there is some difference.

Mr. Cox. A great deal of difference, do you mean?

Mr. McCLURE. I wouldn't say a great deal; no.

Mr. Cox. What about your beer bottle and liquor ware bottles? Is there a great difference in quality there between the bottles you make?

Mr. McCLURE. We think ours are about as good as are made. I wouldn't admit otherwise.

Representative SUMNERS. That is enough, Mr. Cox. Thank you.

Senator KING. Might I ask one question. It isn't quite germane. Has there been any increase in the price of the bottles which you have turned out from the factory for the drug trade since the passage of the Miller-Tydings bill and the Patman bill?

Mr. McCLURE. I would say no. I know nothing about the Miller-Tydings bill except that there is such a thing. I think not. When was the Robinson-Patman Act—it was passed in '36. There was some upward revision then. In '37 they advanced—they had been declining from '34—owing to the pressure of rising cost.

Mr. Cox. I want to read you one more paragraph from the questionnaire, and I shall be through. You say, "We cannot, of course, get more for our goods in this category than can the Owens-Illinois or any other recognized competitor, and to greatly deviate below these levels would result only in our figures being met by competition. The reason for all this is because the Owens-Illinois and, to the same extent, as a matter of ratio of proprietary and prescription business to the total, some of our other competitors, are stronger in those lines than we are, and being more or less a secondary factor in the manufacture of these lines, we follow the lead of the larger interests." Do you remember that?

Mr. McCLURE. I do.

Mr. Cox. And that, you think, is a substantially accurate statement?

Mr. McCLURE. I think so, according to my knowledge of the situation.

Mr. Cox. I think that is all I have of this witness.

The CHAIRMAN. Are there any other questions to be asked of either of these witnesses?

Mr. Cox. I want Mr. McNash tomorrow morning. I think I have finished with Mr. McClure.

The CHAIRMAN. The committee stands in recess until 10:30 tomorrow morning.

(Whereupon, at 4:35 p. m., an adjournment was taken until Thursday, December 15, 1938, at 10:30 a. m.)

INVESTIGATION OF CONCENTRATION OF ECONOMIC POWER

THURSDAY, DECEMBER 15, 1938

UNITED STATES SENATE,
TEMPORARY NATIONAL ECONOMIC COMMITTEE,
Washington, D. C.

The committee met at 10:50 a. m., pursuant to adjournment on Wednesday, December 14, 1938, in the old caucus room, Senate Office Building, Senator Joseph C. O'Mahoney presiding.

Present: Senators O'Mahoney (chairman) and King; Representative Reece; Messrs. Henderson, Arnold, Patterson, Berge, and Peoples.

Present also: Department of Justice Staff for Temporary National Economic Committee study—counsel, H. B. Cox (Special Assistant to the Attorney General); Joseph Borkin, Ernest Meyers, Charles L. Terrel, Benedict Cottone, David Clarke, George Dession, Fowler Hamilton, H. C. Engelbrecht, Victor H. Kramer, J. M. Henderson, Monroe Karasik, Irving Glickfeld, Hyman Ritchin, Norman Bursler, and Seymour Lewis; also chief counsel for Federal Trade Commission Temporary National Economic Committee study, George W. Williams.

The Chairman. The committee will please come to order. Mr. Cox, are you ready to proceed.

Mr. Cox. I am, sir. The first witness this morning will be Mr. F. C. Ball. Mr. Bracken, will you be sworn, too? Mr. Bracken will be sworn.

The CHAIRMAN. Do you and each of you solemnly swear that the testimony you are about to give in this proceeding shall be the truth the whole truth, and nothing but the truth, so help you God?

Mr. BALL. I do.

Mr. BRACKEN. I do.

The CHAIRMAN. Proceed.

TESTIMONY OF FRANK C. BALL, PRESIDENT, BALL BROS., MUNCIE, IND.; A. M. BRACKEN, ASSISTANT TREASURER AND COUNSEL, BALL BROS., MUNCIE, IND.; and E. W. McCALLISTER, PATENT ATTORNEY, PITTSBURGH, PA.—Resumed

Mr. Cox. Mr. Ball, will you give the reporter your name and address?

Mr. BALL. Frank C. Ball, Muncie, Ind.

Mr. Cox. Mr. Bracken, will you do the same?

Mr. BRACKEN. A. M. Bracken, Muncie, Ind.

Mr. Cox. Mr. Ball, you are president of the Ball Bros. Co.?

Mr. BALL. I am.

Mr. Cox. That company manufactures glass containers?

Mr. BALL. Yes, sir.

Mr. Cox. Principally fruit jars?

Mr. BALL. Yes, sir.

THE FRUIT JAR PRODUCERS

Mr. COX. Could either you or Mr. Bracken give us an approximate figures as to the percentage of fruit jars which in any given year are manufactured by your company? If I should suggest around 60 percent, would that be substantially accurate?

Mr. BALL. That is about right.

Representative REECE. That is, Mr. COX, of all the fruit jars in the country?

Mr. COX. Of all the fruit jars in the country.

Mr. BALL. That refers to fruit jars only.

Mr. COX. How long have you been manufacturing fruit jars, Mr. Ball?

Mr. BALL. Since 1882.

Mr. COX. You were one of the licensees under the original Owens suction machine, were you not?

Mr. BALL. Yes, sir.

Mr. COX. Do you remember when you obtained that license?

Mr. BALL. In 1909.

Mr. COX. And you are now a licensee of the Hartford-Empire Co.?

Mr. BALL. Yes, sir.

Mr. COX. How long have you been a licensee of the Hartford-Empire Co., Mr. Ball?

Mr. BALL. Since 1933.

Mr. COX. Had you at any time before entering into the negotiations which led to that license agreement negotiated with Hartford-Empire with respect to obtaining a license under their patents?

Mr. BALL. Before that time we had some little discussion, but not to any extent.

Mr. COX. Nothing ever came of it?

Mr. BALL. No.

Mr. COX. That was about in 1926?

Mr. BALL. In that neighborhood.

Mr. COX. Were you interested at that time in obtaining a license from Hartford-Empire?

Mr. BALL. No, sir; not particularly.

Mr. COX. It was a matter, rather, of that company approaching you than of you approaching that company?

Mr. BALL. Yes, sir.

Mr. COX. Now, were you at some time in 1931 notified by Hartford-Empire that the equipment which you were using to manufacture glass containers infringed their patents?

Mr. BALL. I think they notified us several times that, in their opinion, we were infringing some of their patents.

Mr. COX. And was that one of the circumstances which led to the making of the license agreement in 1932?

Mr. BALL. No, sir; not directly.

Mr. COX. Well, did that circumstance have anything to do with the negotiations which led to that contract?

Mr. BALL. The only thing that had anything to do with it was the decision in the *Hazel-Atlas case* that indicated that perhaps gob feeds might infringe.

Mr. COX. Was the decision in that case as far as your company was concerned the decisive factor which led to the making of the license agreement?

Mr. BALL. Yes, sir.

Mr. COX. Now, in connection with your negotiations with the Hartford-Empire Co., did you make any request to them in connection with the granting of the license? I will strike out that question, if I may, and start again. Whom did you negotiate with in connection with the license of the Hartford-Empire, Mr. Goodwin Smith?

Mr. BALL. When we commenced negotiations; yes, sir.

Mr. COX. With Mr. Goodwin Smith, and in connection with those negotiations, did you suggest to Mr. Goodwin Smith that if you were going to take a license, you wanted a license that was exclusive for fruit jars?

Mr. BALL. Yes, sir; as far as they were in a position to grant it.

Mr. COX. In other words, you wanted a license which would permit you to make fruit jars on their machinery and no one else, so far as they could give it to you?

Mr. BALL. Yes, sir.

Mr. COX. Did Mr. Goodwin Smith ever suggest to you that he was denying other people the right to make fruit jars on Hartford equipment as an inducement to you to enter into this license agreement with him?

Mr. BALL. Yes, sir; he made that suggestion.

Mr. COX. I am going to show you a letter now, Mr. Ball, and ask if you or Mr. Bracken can identify this letter as a letter which you received from Mr. F. Goodwin Smith.

Mr. BRACKEN. Mr. COX, this is not a letter which you got from our files, is it?

Mr. COX. I think not.

Mr. McCallister. It is dated April 22, 1932, and it is addressed to you, Mr. Ball.

Mr. COX. Do you recall whether you in fact received a copy of that letter?

Mr. BALL. I don't recall it; no. Probably it was received, if it was addressed to our company.

Mr. COX. Neither you nor Mr. Bracken recollect ever having seen this letter before?

Mr. BRACKEN. I don't.

Mr. BALL. I don't recall having seen it.

Mr. COX. But you are quite clear in your own mind that Mr. Goodwin Smith spoke to you about denying others the right to make fruit jars in consideration of your accepting a license from his company?

Mr. BALL. Yes, sir; as far as he could, beyond the licenses that he had already granted.

Mr. COX. Then on March 25, 1933, your company took a license from Hartford-Empire Co., you testified a moment ago, and would it be correct to say that that license agreement provided that as long as you made royalty payments, Hartford would not thereafter during the continuance of the license grant to any other person any further license or right to use in the continental United States their machinery for the making of fruit jars for the domestic household use?

Mr. BALL. Yes, sir; in substance that is as we understand it.

Senator KING. Could I interrupt right there? You stated that he said he would give an exclusive right so far as he could, and intimated that he had granted licenses to others. Did he so state that a

license had been granted to other corporations for the manufacture of fruit jars?

Mr. BALL. Limited licenses we understood; yes, sir.

Senator KING. Similar to the one you were seeking?

Mr. BALL. I don't know the shape of their license.

Senator KING. All I want to know is whether he said to you whether or not you had an exclusive license or whether other people had received a license at that time.

Mr. BALL. Exclusive as far as they were in position to grant, which would refer, as we understood it, to companies who had not so far taken licenses. We understood that they had granted limited licenses to one or two companies, but that they had not so far granted licenses to other companies, and, if they entered into this license agreement with us, they would not grant to others.

Mr. COX. I hand you this document and ask you if you or Mr. Bracken can identify it as a correct copy of the license agreement which was entered into between your company and Hartford-Empire.

Mr. BRACKEN. Without reading it all through, I assume that it is.

Mr. COX. Would you have any objection if we offer it subject to correction?

Mr. BRACKEN. No.

Mr. COX. This document which I am about to offer as an exhibit contains in schedule C—

The CHAIRMAN (interposing). What is the document?

Mr. COX. The general feeder license agreement between Hartford-Empire Co. and Ball Brothers Co., dated March 25, 1933. Schedule C thereof shows that as of the date of this contract Hartford had granted certain licenses to other persons; prior to the date of this contract Hartford had granted licenses to certain persons to make fruit jars on the Hartford machines. The companies which have been so licensed included the Salem Glass Works, Gayner Glass Works. Salem is owned by the Anchor Hocking Glass Co. The other two licenses that I wish to mention as having licenses at this time to manufacture fruit jars were Owens-Illinois and Hazel-Atlas.

I should like to offer this document now. It is not necessary to have it printed in the record. I should like to have it certified as an exhibit.

The CHAIRMAN. The document may be admitted for the files and certified without printing in the record.

(The contract referred to was marked "Exhibit No. 143" and is on file with the committee.)

The CHAIRMAN. You were referring to schedule C.

Mr. COX. Schedule C; yes.

There are some other companies listed in that schedule, but they are not licensed for fruit jars.

Mr. BRACKEN. It is only 1, 2, 5, and 6.

Mr. COX. Salem and Gayner, Hazel and Owens. And I think the same document shows the Hazel and Owens licenses were unrestricted as to number.

Mr. McCALLISTER. At least it doesn't say they were restricted.

Mr. COX. The other two were restricted as to number.

Mr. Ball, can you tell us what consideration you paid for this license agreement?

Mr. BALL. I think it was \$400,000.

Mr. Cox. Did that \$400,000 include any damages for past infringement?

Mr. BALL. That was to settle any past damage claims that they might make.

Mr. Cox. I want to ask you one more question about your reasons for entering into this contract. Would it be accurate to say that after the Hazel-Atlas decision you felt that if you did not come to some agreement with Hartford you would be faced with involved and expensive and perhaps lengthy litigation which you didn't wish to endure?

Mr. BALL. Yes, sir. We wanted to escape any such unpleasant litigation, and any claims that they might make for past damages.

Senator KING. Had any suits been instituted by the Hartford or by the Owens against your company for alleged infringement of their patents? Prior to the time you made this settlement with them, had either of those corporations, the Owens or the Hartford, instituted any suits against your company for alleged infringement of their patents?

Mr. BALL. No, sir.

Mr. Cox. At this point, Mr. Chairman, I should like to recall Mr. McNash and Mr. Levis for some brief testimony.

The CHAIRMAN. Before these gentlemen are recalled, let me ask, Is it your intention to develop at this point in the record the provisions of section 2 of this document, which you have just had certified?

Mr. Cox. I had paraphrased the provisions of that section in my question.

The CHAIRMAN. Let me suggest that you read it into the record and ask the witness what his understanding of that section is. It strikes me as being very important.

Mr. Cox. I shall now read into the record the provisions of section 2, the section I paraphrased to you a moment ago, Mr. Ball. That is on page 5.

Mr. BRACKEN. Section 2 of article II?

Mr. Cox. Article II; yes. [Reading from "Exhibit No. 143":]

Hartford agrees, if Ball shall make the minimum payments provided in Section 3 below, that it will not hereafter during the continuance of this General Feeder License Agreement grant to any person, firm or corporation, other than Ball, any further license or right to use in continental United States for the making of fruit jars for domestic (household) use any apparatus and/or method for dropping mold charges of molten glass into molds; *Provided*, however, that said agreement of Hartford not to grant such license or rights to others shall not be held to conflict with or in any way prejudice the rights now outstanding of certain concerns to use, under license from Hartford, apparatus and/or methods for dropping mold charges of molten glass into molds for the manufacture of fruit jars for domestic (household) use, as set forth in Schedule C annexed hereto. Hartford represents that there are no such rights outstanding, other than those listed in said schedule C.

I ask you, Mr. Ball, if it was your understanding that, after the execution of this contract, and during the life of the contract, Hartford-Empire would not be free to grant any new license to any one to use its machinery for the manufacture of domestic fruit jars in the continental United States?

Mr. BALL. Yes, sir; that was our understanding.

Mr. COX. And was the inclusion of this provision in the contract required by you as a condition precedent to your entering into this arrangement?

Mr. BALL. Yes, sir.

The CHAIRMAN. Was that provision of the contract carried out, Mr. Ball, by Hartford?

Mr. BALL. As far as we know; yes.

The CHAIRMAN. You have known of no violation?

Mr. BALL. We have known of no granting of licenses.

The CHAIRMAN. So, to the best of your knowledge, since you entered into this contract with the Hartford-Empire, it has not issued any licenses to any other person or company to use this particular device for the manufacture of fruit jars?

Mr. McCALLISTER. Domestic fruit jars.

Mr. BALL. Yes, sir; that is our understanding.

Representative REECE. Mr. Chairman, I am interested to know if your attorneys studied the question as to whether the Hartford or any other concern had a right to grant a lease on this or other machines which embodied the patented idea with restrictions of any kind.

Mr. McCALLISTER. May I answer that? I was representing Ball Bros. at the time. We had looked not only into the Hartford-Empire patent situation, but also into the law, and we were convinced that Hartford had the right to grant just such a license as you have had outlined to you by Mr. Cox in his reading from the license agreement.

Representative REECE. It is your opinion, then, that under the law a concern who manufactures a patented article has a right to grant a license for the use of that article with restrictions; that is, any restriction which he sees fit to place upon the licensee with reference to the manner in which he might use it, the price he might charge for the product resulting from the use of it, the quantity of—

Mr. McCALLISTER (interposing). You are going too far. I can't say either "yes" or "no" to your question.

Representative REECE. It would seem to me that when a case of restriction was involved that those questions become very material—

Mr. McCALLISTER (interposing). They are material, but your question is far too broad. For example, there was no consideration on our part nor did we have the thought that Hartford-Empire had the right or the opportunity to establish or fix prices on that ware manufactured by or with the aid of these Hartford-Empire feeders. The ware, you must understand, is unpatented ware and we were very, very much of the opinion that no license situation or no patent situation would enable any patentee to fix prices on unpatented articles of commerce.

Representative REECE. But would he, do you think, be able to fix the amount of product produced on the licensed machine?

Mr. McCALLISTER. Yes; we thought that was a proper limitation at the time.

Representative REECE. What is the difference between that and fixing price—

Mr. ARNOLD (interposing). May I say for your information, Congressman, that the Department of Justice has filed a brief in the Supreme Court which deals explicitly with the amount of restric-

tions which are proper under the antitrust laws, and that the law, I think you will agree with me, at present is far from clear.

Mr. McCallister. Yes; I agree with that statement.

The CHAIRMAN. This is a question as to whether or not this was a reasonable restraint of trade.

Mr. McCallister. I understand what he was leading at, and that is why I wanted him to limit it one step at a time.

Representative REECE. May I ask one more question, if you will bear with me. I, of course, realize that this question doesn't deal with the issue involved in your contract there. Is it the opinion of your able patent attorneys—

The CHAIRMAN (interposing). You are addressing a patent attorney. We will all agree he is able.

Representative REECE. I admit it, but he has some assistants, as able as he is. Is there any difference in the right to lease a patented idea, that is, the patent itself, with restrictions, and a right to lease a machine which embodies a patented idea with restrictions?

Mr. McCallister. Well, again I think Mr. Arnold will agree with me when I say that it isn't clear cut. There are some decisions on that point, but you will notice every time a license is granted where restrictions follow the use of the license, if the machine involved is a patented machine, it is not sold; it is merely leased because the law is clearly this: That where a patented machine is sold outright, the purchaser has the right to use that patented machine in every way he cares to use it and without restrictions. Now, in this case, it probably has been, or will be, brought out that the machines here involved are all leased machines.

Mr. Cox. It has been brought out.

Representative REECE. If I may say so, it seems rather strange to me that, as large a question as is involved and as much cost as it has been to certain concerns, that the law in the case might not have been cleared up before now.

Mr. McCallister. Well, our patent law has been developing for the last 100 years, and it develops with litigation. Now, this particular point has not yet been decided by the Supreme Court, so far as I know. I have to put that reservation in.

The CHAIRMAN. Would you care to express an opinion as to whether or not Congress should decide that point by providing by statute that a patentee who leased his patent should not be permitted to require as a consideration for the lease a restriction of production?

Mr. McCallister. I haven't thought about that enough to want to answer it, but I would say this: That we must remember that all restrictions that we are putting on our patent law as we now know it are restrictions to the individual inventor. Of course, it has been brought out here about group inventions, but there are still individual inventors and every restriction that you place on a patent right means value to the individual inventor.

Jumping at a conclusion, from the standpoint of group invention, I should undoubtedly agree with the thought that you implied or expressed.

The CHAIRMAN. Since you have suggested that thought, may I suggest this one to you. Under the law, as it now stands, a corpora-

tion may not file an application for a patent and may not receive a patent. In other words, in the contemplation of the law as drafted by Congress, patents were to be issued to the individual inventors; because Congress had placed no restriction about the assignment of patents there has developed this system under which a corporation may become the repository of an unlimited number of patents, although the law does not contemplate the issuance of patents to a corporation. Now, then, the question: Would you care to express an opinion as to whether or not it would be in the public interest for Congress to provide by statute that there should be a limit to the number of patents which a corporation might obtain by assignment?

Mr. McCALLISTER. Oh, I am sure that wouldn't be good because a patent is like a will; it stands on its own base; it may be of large scope or it may be of very limited scope. Consequently, from the standpoint of numbers we don't imply anything as to quality. Quantity and quality, they are just as important as when we are buying potatoes, so if we just arbitrarily say that a patent holding company shall only hold a hundred patents, that might mean no value for some company and it might mean a tremendous value for another company.

The CHAIRMAN. But you testified here the other day as to the practice which has been termed "fencing in."¹

Mr. McCALLISTER. Yes.

The CHAIRMAN. Whereby one corporation may and in some instances does undertake to study the machines of a competitor, with the view of developing improvements upon that machine so as to compel the competitor to take licenses for the improvements from the corporation undertaking the study, that situation obviously developing a certain restriction of improvement in the art, unless tribute is paid to the corporation which does it.

Mr. McCALLISTER. I think there is a shade of difference in what I testified to and the way you have expressed it.

The CHAIRMAN. Yes; you covered it on both sides.

Mr. McCALLISTER. I was trying to say that in connection with this fencing in when we are considering the competitor's machine, it has been the practice to try to foresee the line of commercial development which the public would demand.

The CHAIRMAN. Perfectly natural for you to do.

Mr. McCALLISTER. And then try to fence in by making those improvements and patenting them, but you see I also said that the man would be optimistic who thought that he could fence in because he would have to foresee the trend of the commercial development and he might and he might not be lucky in his forethought.

The CHAIRMAN. Oh, well, of course, he couldn't be at all certain that his invention would be *the* invention, but it is a practice which is followed, is it not?

Mr. McCALLISTER. As I understand it, yes; and I admit that I have been guilty of suggesting just such a practice.

The CHAIRMAN. Let's not use the word "guilty" in that connection. It was a matter of your study and attempts to secure those patents.

Mr. McCALLISTER. But when I say I suggested such practice, don't misunderstand that I have suggested it to the present witness.

¹ Supra, p. 470.

Mr. ARNOLD. May I ask just two or three questions to tie your testimony up with the main purpose of this hearing, which is the possible effect of the antitrust laws. The situations with respect to different patents and different industries are very dissimilar, are they not?

Mr. McCALLISTER. Yes.

Mr. ARNOLD. And one way—and I am not asking you at this point to give an opinion on the advisability of that way—of treating different situations according to their facts, and not having a rule which spreads a regulation over all situations, would be through the application of the antitrust laws, wouldn't it?

Mr. McCALLISTER. Undoubtedly.

Senator KING. Under the fourteenth amendment a corporation is regarded as a person. Is there any inhibition in the law, or any moral turpitude involved, in corporations acquiring patents?

Mr. McCALLISTER. No. I was going to correct the chairman—

The CHAIRMAN (interposing). Wait a minute. The chairman didn't even suggest that, so that there couldn't possibly be any corrections on that basis.

Mr. McCALLISTER. Correct the idea that the chairman gave me in one of his questions. The law does provide for assignments of applications, therefore we do talk of patents being issued to corporations, but the application for the patent must be filed by the first, must be granted to the first, inventor. He can assign it either before or after. If he assigns it before, then it goes direct to the corporation.

Senator KING. I am not speaking as to the wisdom of permitting corporations to become assignees of patentees, but the point I am trying to elicit is that so far as I understand the law, there is no inhibition or prohibition against you, if you have a patent, assigning it to Senator O'Mahoney and myself, if we have a corporation.

Mr. McCALLISTER. Absolutely not.

Senator KING. And the Supreme Court has frequently said the holder of a patent may use it or not use it, as he pleases.

Mr. McCALLISTER. That is right.

Senator KING. And he may assign it to whom he pleases?

Mr. McCALLISTER. That is right.

Senator KING. And with such restrictions as he sees fit?

Mr. McCALLISTER. There are limitations to the restrictions.

Senator KING. Without violation of the antitrust laws?

Mr. McCALLISTER. Perhaps, that is one thing that is involved, and I have tried to point to another one. You cannot assign a patent on a machine or process and hope to fix prices on the product of that machine, or the process, if the product is an unpatented product.

The CHAIRMAN. In other words, you will express as your opinion the thought that it would be possible for a licensee to attach to his license restrictions which in your judgment would be in violation of the antitrust laws?

Mr. McCALLISTER. Oh, yes; and such restrictions have been attached.

The CHAIRMAN. And the whole question with respect to these restrictions is whether or not they are such as would come within the rule of reason.

Mr. McCALLISTER. I think you are right in that.

Senator KING. The patentee may transfer or assign his patent to whom he pleases with such restrictions as would be regarded as reasonable in the light of the common law and our economic and social situation.

Mr. McCALLISTER. Yes. Such a transfer would probably not be termed an assignment by the technical patent man. It would be termed a license carrying restrictions.

Senator KING. You spoke about the fencing in. Do not corporations or individuals who have patents, who have for instance a primary patent, frequently try to obtain patents upon what some would call immaterial, I would say ancillary matters, so that they would strengthen the basic patents which they have?

Mr. McCALLISTER. A very good example of that is the fountain pen. Assume we are 100 years back, the man who has the fundamental patent on the fountain pen would undoubtedly try to get the patent on the self-filling device, because he would assume that the commercial trend would be in simplification. And there we have the situation, if the man owning the fundamental patent on the fountain pen is not fortunate enough to acquire the patent on the self-filling device, we have a checkmate. The man owning the self-filling device must build a fountain pen to get it to the customer. Consequently, he is stopped by the man who has a fundamental patent on the fountain pen. On the other hand, the fact that a self-filling device is in existence makes the public want that self-filling device, but the owner of the patent on the pen per se can't furnish it because of the adverse ownership of the filling device patent.

You see, each patent is an entity in itself. It must be based on invention, and even though we call that invention an improvement.

Senator KING. Are not many of the patents held by individuals as well as by corporations ancillary—using your expression—to the basic patent, so that the person who has a basic patent may have a dozen or 20 or 30 minor patents for the purpose of protecting the basic patent?

Mr. McCALLISTER. Necessarily so. You take the radio situation. Now I am not up on radio patents and I am not trying to intimate that I am, but I can assume that possibly the broad patent on the radio has expired within the last several years, but still we know that there are a great many patents still outstanding on radios, and that they give each manufacturer at least a talking-point because he knows his competitor cannot encroach upon his own patented field.

Mr. Cox. Before I recall the witnesses I mentioned a moment ago, I would like to ask Mr. Ball two or three more questions. Mr. Ball, under this contract which was made in 1933,¹ you pay royalties to the Hartford-Empire Co., that is right, isn't it?

Mr. BALL. It is.

Mr. Cox. Mr. Ball, were you ever told before you signed this contract that those royalties were going to be divided with Owens-Illinois and Hazel-Atlas?

Mr. BALL. No, sir; we had no idea of it.

Mr. Cox. When did you find out about that, Mr. Ball?

Mr. BALL. Read it in the newspaper a couple of days ago.

¹ Entered as "Exhibit No. 143," supra, p. 554.

Mr. Cox. I think now I will call Mr. McNash. I would like to have Mr. Ball stay. I might call Mr. Levis at the same time.

I would like to say, as far as Mr. Levis is concerned, that yesterday afternoon I did excuse him, and he is here again this morning because we asked him last night to come back and he very kindly agreed to do so.

TESTIMONY OF J. H. McNASH, PRESIDENT, HAZEL-ATLAS GLASS CO., WHEELING, W. VA., AND WILLIAM E. LEVIS, PRESIDENT, OWENS-ILLINOIS GLASS CO., TOLEDO, OHIO—Resumed

Mr. Cox. Mr. McNash, you were aware, of course, of the negotiations between Hartford-Empire and Ball Brothers looking toward the issuance of a license to Ball Brothers.

Mr. McNASH. That is correct.

Mr. Cox. And would it be an accurate statement to say that you were interested in seeing that Ball Brothers did take a license from Hartford-Empire?

Mr. McNASH. We might have had a selfish interest in that.

Mr. Cox. I wasn't describing it in such an invidious term, Mr. McNash. What I really was trying to develop was that you participated in some discussion with respect to that license, did you not?

Mr. McNASH. Correct.

Mr. Cox. Mr. McNash, I am going to hand you a letter which is a certified copy taken from your files and ask you if you can identify that as a letter which you wrote, or a copy of a letter which you wrote.

Mr. McNASH. That is correct.

Mr. Cox. This is a copy of a letter written by Mr. McNash to Mr. Levis dated September 1, 1932. Mr. McNash, I wish to read a paragraph of that letter to you and then I want to ask you some questions about it. The paragraph reads as follows [reading from "Exhibit No. 144"]:

About Ball—I really don't have any additional views. This Company, however, is willing to go pretty far, as I indicated in New York, to give Ball what he wants as long as that want does not actually cramp our style. I don't mean by this that your Company or this Company should actually pay Ball to come in, but I believe the Hazel-Atlas Glass Company could restrict itself in such a way that there actually would not be a penalty. For instance, have the quantity of jars that we are allowed to make under the license from Hartford-Empire for fruit jars, be sufficiently large to have an excess each year to accumulate to the benefit of some year when we have a repetition of the conditions that existed in 1931.

I want to ask you, Mr. McNash, whether it was your understanding at that time that Mr. Ball wished to have your company make some agreement to restrict its production of fruit jars?

Mr. McNASH. That is true.

Mr. Cox. Is that correct, Mr. Ball, did you wish to have the Hazel-Atlas Co. restrict its production of fruit jars?

Mr. BALL. Yes; we did.

Mr. Cox. And you had made that request to Mr. Goodwin Smith?

Mr. BALL. Yes, sir.

Mr. McNASH. It is true, is it not, that that paragraph refers only to restriction as to the quantity of jars we might make?

Mr. Cox. As to fruit jars you might make. It has nothing to do with any other line of work.

Mr. McNASH. And it has no other significance.

Mr. Cox. I would like to have it marked as an exhibit and admitted, if I may.

The CHAIRMAN. It may be admitted to the record.

(The letter referred to was marked "Exhibit No. 144" and is included in the appendix on p. 788.)

Mr. Cox. Now, Mr. McNash, will you tell us whether any such agreement and understanding was finally made on the part of your company?

Mr. McNASH. We were perfectly willing to make such an agreement. I think the restriction discussed for our company was 300,000 gross per year. That was of no particular moment, for the reason that our business did not amount to that much, actually, per year, following 1931.

Mr. McCALLISTER. Did you hear his answer, Mr. Ball?

Mr. BALL. I didn't get all of it.

Mr. McNASH. I said, Mr. Ball, that the restriction discussed was one of 300,000 gross per year. We were willing to assume that restriction, because actually we had not sold since 1931 that amount of jars.

Mr. Cox. In 1931 you sold about 500,000.

Mr. McNASH. And I might add we have not sold near that amount since.

Mr. Cox. In fact, since 1931 your sales of fruit jars have always been below 300,000 gross.

Mr. McNASH. That is right, and not in any attempt to stay below the 300,000 gross.

Mr. Cox. Is it your present understanding, Mr. McNash, that there is no agreement on the part of your company to limit your production to 300,000?

Mr. McNASH. I am not sure whether there is or is not. We were perfectly willing to sign such an agreement. Whether that willingness evolved itself into a contract, I am unable to say.

The CHAIRMAN. Did you sign the agreement?

Mr. McNASH. I am unable to say, because I have forgotten whether I have or have not signed such a contract. I will admit, as I said a while ago, a perfect willingness to sign such an agreement.

Mr. Cox. I am going to read to you from this memorandum, a certified copy of a memorandum taken from your files, which I am going to ask you in a moment if you can identify. This document is entitled, "Hartford-Empire Co.—Memorandum," dated February 9, 1933, and begins [reading from "Exhibit No. 145"]:

The Hazel-Atlas Glass Company have a nonrestricted, nonexclusive license from Hartford-Empire to make fruit jars.

Negotiations are under way looking forward to Ball Brothers taking a license.

Hartford really offered Ball the residual rights excepting as to Hazel and Owens-Illinois. Ball really wants more than that; he wants some restriction placed upon Owens-Illinois and Hazel—

I expect I had better read it all—

Various conversations have been had on this subject between the interested parties.

During some of these conversations the atmosphere became very tense. Even questions of good faith were involved.

All these things finally came to the top Friday, February 3, in New York. Messrs. F. C. and G. A. Ball questioned me up to about a quarter to six on that day, in connection with the attitude of Owens-Illinois in case an agreement could be reached.

I want to ask you there, Mr. McNash, if you can tell us who else was at that meeting in New York besides Mr. F. C. Ball and Mr. G. A. Ball.

Mr. McNASH. At this particular discussion I don't believe anybody, with the exception of the Ball brothers and myself.

Mr. Cox. I see. That was the meeting on February 3.

Mr. McNASH. At that particular time.

Mr. Cox. At that particular time.

Mr. McNASH. Yes.

Mr. Cox. Did you have any other meeting on that same day?

Mr. McNASH. I think the meeting that day lasted the better part of the day on this subject.

Mr. Cox. On this subject.

Mr. McNASH. That is right.

Mr. Cox. Very well; I will begin reading from the memorandum again. [Reading from "Exhibit No. 145:"]

I explained my view of the thing with respect to Owens-Illinois, and why.

Apparently, there was a desire on the part of Messrs. F. C. and G. A. Ball to arrive at a satisfactory situation.

As a consequence of this, I was willing to change my view to some extent with respect to Hazel's position in this matter, and restrict our license to 300,000 gross per year, without any mention in the contract of any conditions modifying this amount.

Previous to this I had been insisting upon some understanding in event of an increase in the use of fruit jars for the domestic trade; or some repetition of what took place in September of 1930 in our New England territory, which might put us over our restricted license; or, a repetition of what transpired in 1931, when, by a combination of many circumstances, an unusual demand was had for domestic fruit jars.

I told Mr. F. C. and G. A. Ball it was not necessary to have these modifications in the contract as far as I was concerned, if they (Messrs. F. C. and G. A.) would permit me to tell my story to Mr. F. Goodwin Smith in their presence, inasmuch as he would have to be the umpire under the licensing arrangement, and for them to see whether my statement was correct or not.

Mr. F. Goodwin Smith came into the room. I presented my story as outlined, particularly with respect to an increase in the use of jars generally, or some recurrence in some particular territory of what happened in New England in 1930, or a repetition of 1931 generally, and the fact that the Ball Brothers had said that in these respects a very liberal interpretation should be given to our restriction.

Messrs. F. C. and G. A. Ball confirmed my understanding in Mr. F. Goodwin Smith's presence, and I am asking Mr. F. Goodwin Smith to make a record of this, certify to it, to be in his files as a part of the atmosphere, at least of this Ball situation, so that anyone following Mr. F. Goodwin Smith will know just how the situation is to be handled.

I am certifying to this record here for the same purpose.

Mr. McNASH. So what have you?

Mr. Cox. Will you identify that as your memorandum?

Mr. McNASH. That is correct.

The CHAIRMAN. It may be received.

(The memorandum referred to was marked "Exhibit No. 145" and is included in the appendix on p. 789.)

Mr. Cox. Mr. McNash, does that refresh your recollection at all as to whether any agreement was actually made?

Mr. McNASH. It does not. I said I was perfectly willing to sign one, but whether I did or not I do not remember. I might ask if you found any.

Mr. Cox. We found no such written agreement.

Mr. McNASH, what I suggest to you now is that the last paragraph of this memorandum would appear to indicate that the parties decided to handle the matter by an agreement which was not in writing. Would you accept that suggestion?

Mr. McNASH. No, sir.

Mr. Cox. You would agree that there is language in here which indicates that nothing was to be put into the contract as to the restrictions on production, would you not?

Mr. McNASH. There was nothing in this memo to prevent a contract being drawn restricting us to 300,000 gross per year.

Mr. Cox. I am going to ask you one more question, Mr. McNash, and I think I shall have finished with you on this subject, so far as you are concerned.

Mr. McNASH. Where do you find that suggestion?

Mr. Cox. I call your attention to this language particularly [reading from "Exhibit No. 145"]:

As a consequence of this I was willing to change my view to some extent with respect to Hazel's position in this matter, and restrict our license to 300,000 gross per year, without any mention in the contract of any conditions modifying this amount.

Mr. McNASH. That refers to the modifications of the 300,000 gross per year as a result of some unusual demand for fruit jars. It does not refer to the 300,000 gross.

Mr. Cox. You are quite sure about that?

Mr. McNASH. I am positive.

Mr. Cox. What would be the point of having any provision as to the unusual circumstances if you weren't going to have an understanding as to the 300,000?

Mr. McNASH. I don't say there is not an understanding as to the 300,000 gross, but I cannot tell you as to whether it was put in writing and a contract signed.

The CHAIRMAN. What is the purpose of the second paragraph from the end, beginning, "Messrs. F. C. and G. A. Ball"?

Mr. McNASH. That relates to this: We were willing to assume a restriction of 300,000 gross per year, but we wished it fully understood that in case there was a favorable circumstance in connection with the use of fruit jars, as resulted in 1931, from a large fruit crop, cheap sugar, the disposition on the part of the housewife to conserve, if there was a repetition of that, we were not bound by any 300,000 gross per year.

The CHAIRMAN. I have in mind whether or not it was your understanding at the time of this conference that no written contract should be made but that in lieu of a written contract there should be a memorandum of exactly what transpired to be placed in the files of Mr. Smith so that he or anybody who succeeded him would know exactly what the oral understanding was. In other words, when I read this paragraph, which apparently was your language—

Mr. McNASH (interpolating). Correct.

The CHAIRMAN (reading from "Exhibit No. 145") :

Messrs. F. C. and G. A. Ball confirmed my understanding in Mr. F. Goodwin Smith's presence, and I am asking Mr. F. Goodwin Smith to make a record of this, certify to it, to be in his files as a part of the atmosphere, at least of this Ball situation, so that anyone following Mr. F. Goodwin Smith will know just how the situation is to be handled—

Would I be justified, after reading that language, in inferring that it was the specific intention of all the parties to this conference that there should not be a written contract, but that in lieu of such a written contract there would be a memorandum of the understanding?

Mr. McNASH. I don't think your view is correct.

The CHAIRMAN. Thank you.

Mr. Cox. I have one more question that I would like to ask about that which I was going to ask a moment ago and didn't get to, Mr. McNash, and after I have asked that I think we will be through so far as you are concerned.

Do you have any opinion as to why it was considered desirable or necessary for Mr. F. Goodwin Smith to make a memorandum to put it in his files in these circumstances?

Mr. McNASH. The question is on the 300,000 gross per year restriction. If we exceeded that, I didn't want anybody coming to me telling me that we were not actually following a written contract, if I could justify it by conditions, repeating what happened in 1931 or what happened in 1930. In the fall of 1930 there was an unusual demand for fruit jars in the New England States. That happens to be the territory where our location of plants gives us an advantage. We can serve it much more rapidly. That demand didn't exist in any other part of the United States. We took advantage of it by making the jars that the trade required.

Now, a situation of that kind might put us over 300,000, but I wanted the modification of this 300,000 gross to be allowed if those conditions repeated themselves.

Mr. Cox. Why was a modification necessary, if there was no restriction to 300,000 gross in the first place?

Mr. McNASH. I think as a result of this there actually is no restriction, but we were perfectly willing to sign a contract restricting ourselves to 300,000 gross per year.

Mr. Cox. Mr. Ball, did you have any information or knowledge as to any agreement on the part of anyone else, of either Hazel-Atlas or Owens-Illinois, to restrict their production in connection with the granting of a license to you?

Mr. BALL. It was our understanding that they would not exceed the 300,000 gross which was recognized as being as much as they had produced before unless it was in some unusual year, when the demand was unusually large. That was talked about, and that was Mr. McNash's desire at that time, and we felt that if there was an unusual demand it would fall to all of the manufacturers and would not harm us particularly if the demand set in and they could supply more than that.

Mr. Cox. In the absence of such unusual circumstances it was your understanding that their production of fruit jars would not exceed 300,000 gross?

Mr. BALL. It was our understanding that it would not, because it had not before that time even come up to that amount.

Mr. COX. Except in the one year Mr. McNash has mentioned. I think, Mr. McNash, that I have finished with you.

The CHAIRMAN. Did you certify to this memorandum?

Mr. McNASH. No, sir.

The CHAIRMAN. The concluding sentence is [reading from "Exhibit No. 145"]:

I am certifying to this record. * * *

Mr. McNASH. You asked me about your memorandum.

The CHAIRMAN. I am asking about the memorandum that is in the record.

Mr. McNASH. I am pretty sure I did.

The CHAIRMAN. Did you ever ask your attorney whether or not that signature made it a written contract?

Mr. McNASH. I did not. Does it?

The CHAIRMAN. I think so.

Mr. COX. I think, Mr. McNash, if you will move now, and let Mr. Levis take your place, we will proceed.

Mr. Levis, I wanted to ask you about the attitude of your company with respect to the transactions between Hartford-Empire and Ball Bros. Did you participate to any extent in the discussions which preceded the agreement between Hartford and Ball Bros.?

Mr. LEVIS. Yes; from time to time.

Mr. COX. And would it be an accurate statement to say that you, your company, too, was interested in seeing that Ball Bros. took a license from Hartford-Empire?

Mr. LEVIS. Yes, sir. We got half of the back damages and we got half of the royalty they paid, if any. We were trying to liquidate this unsatisfactory license business I explained yesterday, and I got everything I could.

Mr. COX. Was it your understanding that as a part of that transaction, Ball Bros. wanted your company to agree to limit its production of fruit jars to 100,000 gross per year?

Mr. LEVIS. That was discussed, and a form of agreement was submitted to us and we refused to enter into it.

Mr. COX. Is it your understanding now that there is no agreement on the part of your company, either oral or written, that your company, so long as that license between Hartford-Empire and Ball Bros. is in effect, will not produce in excess of 100,000 gross of fruit jars in any year?

Mr. LEVIS. I have testified under oath, Mr. Cox, in this proceeding that we had no restrictions under our Hartford licenses.

Mr. COX. Of course you can make fruit jars on your own machines, too, can't you, so this is a slightly different question than the one involved as to the restrictions under the Hartford license.

Mr. LEVIS. There is no restriction so far as our ability to make fruit jars is concerned.

Mr. COX. You feel your company is absolutely free to make as many fruit jars as you want to to sell in any given year?

Mr. LEVIS. Yes, sir.

Mr. COX. Of course, since 1932 it is true, isn't it, Mr. Levis, that your company has never made or sold more than 100,000 gross of fruit jars?

Mr. LEVIS. They have tried to sell more, sir.

Mr. COX. But you haven't made any more than that?

Mr. LEVIS. It is pretty hard to sell more than that against Mr. Ball.

Mr. COX. Well, there were two years when you did it, Mr. Levis.

Mr. LEVIS. What years were they, sir?

Mr. COX. 1931 and '32.

Mr. LEVIS. We had thrift then, and cheap sugar and cheap fruit. We will never have that for some time, and that is the only time fruit jars are used. We didn't have the reuse of packers' ware for jars, and all sorts of items of that kind.

Mr. COX. So, as far as your company is concerned, you are quite satisfied that, irrespective of exceptional conditions such as Mr. McNash was talking about, you are free to produce as many fruit jars as you like in any year.

Mr. LEVIS. As far as our company is concerned I have never signed an agreement to restrict, and I am informed by our counsel that there are no agreements in existence.

Mr. COX. Quite apart from signing such agreements, you have reached no oral understandings with anyone with respect to the same thing?

Mr. LEVIS. I can't answer that, Mr. Cox.

Mr. COX. Why can't you answer that?

Mr. LEVIS. I don't consider that would be an agreement. I may have talked about it, but I have no agreement of any kind.

Mr. COX. What I am really trying to find out is whether you gave anyone an oral promise or assurance that you would not produce more than 100,000 gross in any given year.

Mr. LEVIS. I don't recall it.

Mr. COX. Would you say definitely that you never had done so?

Mr. LEVIS. No; I probably may have. I have given a lot of people assurances on matters of that kind in a 25 years' business career.

Mr. COX. That is the kind of assurance you might be likely to remember, isn't it, Mr. Levis?

Mr. LEVIS. No, sir; I have forgotten a lot of them.

Mr. COX. Mr. Ball, at the time you signed this agreement, what was your understanding as to the position which Mr. Levis' company was to have as far as his production of fruit jars is concerned? Was it your understanding that they were not to produce more than 100,000 gross in any year?

Mr. BALL. You are referring to the agreement with the Hartford-Empire Co.?

Mr. COX. That is right.

Mr. BALL. No; there was no understanding in that agreement as far as I know that they would not, but there was a general understanding that they would not. There is nothing in the contract to the effect that they were restricted from any quantity.

Mr. COX. I think that I have finished with both Mr. McNash and Mr. Levis on this particular subject matter, so perhaps it would be a good place for the committee to ask any questions it may have.

The CHAIRMAN. Do any members of the committee desire to propound questions to any of these witnesses?

Senator KING. Mr. Levis.

Mr. LEVIS. Yes, sir.

Senator KING. You would respect an oral agreement, would you not, where it was quid pro quo as quickly as you would a written one?

Mr. LEVIS. Yes, sir.

Senator KING. I would assume that. If you didn't do it, I wouldn't think it very ethical. Now, coming to that question which was propounded to you, did you make an oral agreement, bottomed upon matters of consideration or out of your own generosity, under the terms of which you limited the amount of production of glass fruit jars by your company?

Mr. LEVIS. Senator, I don't believe that I ever obligated the Owens-Illinois Co. to restrict their business in any respect. I may have discussed these situations. I have known Mr. Ball for a great many years and I have been in a great many negotiations with him, and I think he would understand anything I would say without an agreement.

Senator KING. Has there been any controversy between you and Mr. Ball, or between the Hartford Co. and Mr. Ball and yourself, in a triangular way, which would call into question any alleged agreement which you had entered into restricting production?

Mr. LEVIS. Not that I know of, sir.

Senator KING. That is all.

Mr. Cox. Mr. Levis, before you go, do you recall this memorandum which we discussed yesterday which Mr. Martin identified?¹ I want to get you to identify this for the record. It is the one I read the paragraph from.

Mr. LEVIS. My comment in the record was that it was one of many memoranda from Mr. Carter. I didn't recall it specifically. I know if Mr. Martin turned it in, it was from our files.

Mr. Cox. Are you prepared to accept it as coming from your files? I'd like to offer it now as a memorandum which was discussed yesterday. I neglected to offer it at that time.

The CHAIRMAN. It may be received.

(The memorandum referred to was marked "Exhibit No. 146" and is included in the appendix on p. 789.)

Mr. Cox. I think I am finished with Mr. Levis.

The CHAIRMAN. May I ask you whether you had in your own mind any understanding of a limitation to which you have expressed willingness to adhere, a limitation on production, to these other gentlemen?

Mr. LEVIS. Sir, I tried yesterday and the day before to point out to the committee that from 1929 to 1935 we had many, many agreements, many participations, many memoranda; that from 1929 to 1935 I used my best efforts to saw it all off. In 1935 I sawed it all off, and I then went on carrying on a business of manufacturing and selling containers of various types, and found in the clear vision of hindsight that that decision proved a more profitable transaction for the shareholders of our company. I had lots of trading talk from along about 1913.

The CHAIRMAN. That is not the subject to which I am directing your attention.

¹ See *supra*, p. 502 et seq.

Mr. LEVIS. If I had any such understanding in 1935, I sawed it off.

The CHAIRMAN. You are speaking now, are you not, of having sawed off the patent business?

Mr. LEVIS. I canceled all contracts.

The CHAIRMAN. Respecting patents?

Mr. LEVIS. Respecting licenses. I canceled all of the contracts.

The CHAIRMAN. Very good. Now, that, of course, is not my question. I understand that to be quite clearly your testimony, but this morning it has been developed here by the testimony of Mr. Ball and the testimony of Mr. McNash that the Hartford-Empire Co. was seeking to induce Mr. Ball and his company to become licensees of the Hartford machines. The Hartford Co. was very anxious to have that circumstance brought about. In order to bring it about, Mr. Ball expressed the opinion that there should be a limitation on the amount of production by the Hazel-Atlas Co., and there was some discussion at this time with respect to the production by Owens-Illinois as well as by Hazel, and according to the memorandum of Mr. McNash,¹ at this conference held in New York on February 3, Mr. Ball really wanted some restriction placed upon Owens-Illinois as well as Hazel.

Now, we have before us a memorandum, acknowledged by Mr. McNash, in which he stated that there was a general understanding that there would be a limitation by Hazel to 300,000 gross in a year. Mr. McNash testifies that that was in excess of his production and it really didn't amount to anything. Now what I am trying to develop is not whether you had any contract, not whether you made any promise, but whether you had any gentlemen's understanding similar to that which Mr. McNash has testified to upon which Mr. Ball can rely, that there is a figure above which you won't go in the production of these jars.

Mr. LEVIS. My answer to that is there is no contract and so far as I am concerned I have no such understanding.

The CHAIRMAN. Very good.

Senator KING. I think we might supplement the Senator's statement. I understood Mr. McNash's statement and also Mr. Ball assenting that notwithstanding the limitation of 300,000, in the event of some extraordinary situation, a large increase in the fruit crop and cheap sugar, then the 300,000 jars might be exceeded.

The CHAIRMAN. Yes.

Mr. McNASH. It is a restriction that isn't a restriction.

Senator KING. That is, the limitation to 300,000 did not extend to extraordinary circumstances such as I have just indicated.

That is all.

The CHAIRMAN. That is all.

Mr. COX. Are we going on now?

The CHAIRMAN. We will stand in recess until 2 o'clock.

(Mr. Levis was excused.)

(Whereupon, at 12:05 p. m., a recess was taken until 2 p. m. of the same day.)

¹ See "Exhibit No. 145" appendix, p. 789.

AFTERNOON SESSION

(The committee resumed at 2:15 p. m. on the expiration of the recess.)

The CHAIRMAN. The committee will please come to order.

Mr. COX, are you ready to proceed?

Mr. COX. I am. I should like to have another witness sworn at this time. I think it would save time to have him take the stand now and answer questions.

The CHAIRMAN. Will you call the witness?

Mr. COX. Mr. Collins.

The CHAIRMAN. Mr. Collins, do you solemnly swear that the testimony you are about to give in this proceeding shall be the truth, the whole truth, and nothing but the truth, so help you God?

Mr. COLLINS. Yes, sir.

TESTIMONY OF I. J. COLLINS, PRESIDENT, ANCHOR HOCKING GLASS CO., LANCASTER, OHIO; FRANK C. BALL, PRESIDENT, BALL BROS., MUNCIE, IND.; A. M. BRACKEN, ASSISTANT TREASURER AND COUNSEL, BALL BROS., MUNCIE, IND.; AND E. W. McCALLISTER, PATENT ATTORNEY, PITTSBURGH, PA.—Resumed

Mr. COX. Mr. Collins, will you give the reporter your name and address and tell what your occupation is?

Mr. COLLINS. I. J. Collins, Lancaster, Ohio, president of the Anchor Hocking Glass Co.

Mr. COX. You are president of the Anchor Hocking Glass Co.?

Mr. COLLINS. Yes.

Mr. COX. That is a company which is engaged in the manufacturing of a general line of glass containers. Is that right?

Mr. COLLINS. That is right.

Mr. COX. How long has that company been in existence, Mr. Collins?

Mr. COLLINS. January 1, 1938.

Mr. COX. It came into existence as the result of a merger of some other companies, including glass companies and companies engaged in the manufacturing of products used in connection with glass containers. Is that correct?

Mr. COLLINS. That is correct.

Mr. COX. What did you do before the organization of the Anchor Hocking Co.?

Mr. COLLINS. I was president of the Hocking Glass Co. and General Glass Co.

Mr. COX. General Glass Co.? Will you tell us who owned the stock of the General Glass Co.?

Mr. COLLINS. Hocking Glass Co.

Mr. COX. A wholly owned subsidiary?

Mr. COLLINS. Right.

Mr. COX. At the end of 1932, it is true, isn't it, Mr. Collins, that the General Glass Co. was a licensee of Hartford-Empire?

Mr. COLLINS. Right.

Mr. COX. And under its license it was permitted to manufacture fruit jars; is that correct?

Mr. COLLINS. That is correct.

Mr. COX. Before I go into that, I want to ask you one more question about the Anchor Hocking Corporation. That, in point of size, is about the third largest in the industry; is it not?

Mr. COLLINS. I think that is correct.

Mr. COX. To return to the General Glass Co. and the license it had from Hartford-Empire to manufacture fruit jars, at a date in the spring of 1933 that license, so far as it permitted the manufacture of fruit jars, was canceled. Is that correct?

Mr. COLLINS. That's right.

Mr. COX. Can you tell us what the consideration for that cancellation was?

Mr. COLLINS. \$100,000.

Senator KING. Was it canceled while it was a subsidiary or after it had been absorbed, or did the absorption, if it was absorbed, have anything to do with the cancellation?

Mr. COLLINS. It had nothing to do with the cancellation. It was while it was a subsidiary of the Hocking Glass Co.

Mr. COX. Now, Mr. Ball, I would like to ask you a question. Do you recollect whether your discussions with Mr. Smith prior to the making of your license agreement with the Hartford-Empire touched upon the matter of the license which the General Glass Co. had to make fruit jars? Was that matter discussed?

Mr. BALL. Yes, sir.

Mr. COX. Do you recall whether you requested Mr. Smith to arrange to have that license canceled as a condition precedent to your taking a license from Hartford-Empire?

Mr. BALL. Yes, sir. That was one of the understandings, that some of those who had partial licenses and whole licenses would be canceled, so that they could deliver to us as near as possible the exclusive use of the patents.

Mr. COX. Mr. Collins, was that license to the General Glass Co., so far as it related to fruit jars, a license which restricted the quantity that could be produced on the machines?

Mr. COLLINS. There were no restrictions, as I remember. I think that is true.

Mr. COX. Do you recall whether it was ever suggested to you, Mr. Collins, that that license should be canceled without your receiving any consideration for it?

Mr. COLLINS. I don't think so. It might have been. We felt there was some value; naturally we wanted to get something for it if we were going to cancel it.

Mr. COX. That was a matter which you and Mr. Levis and Mr. McNash discussed; was it not?

Mr. COLLINS. No; I never discussed it with Mr. McNash.

Mr. COX. You don't remember discussing it with Mr. McNash and Mr. Levis while at White Sulphur Springs in the year of 1933?

Mr. COLLINS. I don't think so.

Mr. COX. But at any event you did receive \$100,000 in cancellation of that license?

Mr. COLLINS. Yes.

Senator KING. From whom?

Mr. COLLINS. From the Hartford-Empire Co.

Mr. Cox. Mr. Collins, there is one more matter that I wish to ask you about. Thereafter, in 1933, do you recall some correspondence with the Hartford-Empire Co. with respect to sales of packers' ware by the General Glass Co. in competition with fruit jars?

Mr. COLLINS. In what year?

Mr. COX. This would be in 1933, in August.

Mr. COLLINS. I don't recall it.

Mr. Cox. I am going to show you a letter now. First, you might tell me this, Mr. Collins. As an experienced glass manufacturer, is it your opinion that a packers' ware jar might be sold and used for the same purposes as a fruit jar in certain situations?

Mr. COLLINS. I think so.

Mr. Cox. They are enough alike in size and shape so that, as to use, they might be interchangeable?

Mr. COLLINS. That is right.

Mr. Cox. Now, I am about to hand you a letter dated August 17, 1933, addressed to you, which reads as follows [reading from "Exhibit 147"]:

I am enclosing copy of a letter just received from Mr. F. C. Ball, relative to packers' jars sold into the domestic fruit jar field.

We discussed this in New York and you assured me that you were using every effort to keep jars out of this field.

I feel, therefore, that in fairness to you, you should be advised about this complaint from Ball, as I know you won't misunderstand my sending it to you.

Mr. Cox. The rest of the letter is not germane. It is signed "Sincerely yours, Roger Eldred."

Will you look at that and see if you can identify it as a letter which you in effect received?

Mr. COLLINS. Evidently I received it. It is addressed to me.

Mr. COX. You are prepared to identify it as a letter you received?

Mr. COLLINS. Yes.

Senator KING. Who is the sender?

Mr. Cox. The sender is Mr. Eldred. Can you tell us who Mr. Eldred is?

Mr. COLLINS. Mr. Eldred is, I think, the general manager of the Hartford-Empire Co.

Mr. Cox. Vice president, I believe.

I should like to have that letter marked and admitted in evidence.

The CHAIRMAN. It may be so admitted.

(The letter referred to was marked "Exhibit No. 147" and is included in the appendix on p. 791.)

Mr. Cox. Now Mr. Ball, do you recall about in August 1933, complaining to Mr. Eldred, of the Hartford-Empire Co., about sales of packers' ware in competition with fruit jars which your company was producing?

Mr. BALL. We did complain several times of their being sold in place of domestic jars. It was our understanding that we were to have the exclusive rights for domestic jars, and these so-called packers' jars were sold in place of domestic jars and we thought that it was an unfair practice.

Mr. Cox. I am going to show you a photostatic copy of a letter that purports to be a letter addressed by you to Mr. Eldred, together with certain attachments, and ask whether you or Mr. Bracken can identify the letter as one which you in fact wrote.

Mr. BALL. Yes, sir; I think that is authentic.

Mr. Cox. In order that the committee may understand what kinds of ware are involved, we have some samples here. This, I believe, is a fruit jar produced by your company, is that correct?

Mr. BALL. That is correct.

Senator KING. Mark it "A" on the side.

Mr. Cox. It is marked "A" on the side, Senator.

And this is a packers' ware jar produced by your company, is it not?

Mr. BALL. I don't know that it was produced by our company, but it is a packers' jar; yes sir [examining jar]. Yes, sir; that was produced by our company. It has our company mark.

Mr. Cox. The committee will note the two jars are the same size and shape. In fact, the cap that normally goes on the fruit jar can be put on the packers' ware jar like that [demonstrating].

Then it was your understanding that as a result of your license agreement with Hartford-Empire, Mr. Ball, you were to have exclusive rights for the manufacture of fruit jars and that right carried with it the prevention of the kind of competition that you met from packers' ware jars when they were used for fruit-jar purposes; is that right?

Mr. BALL. Yes, sir.

Senator KING. I understood the witness to testify this morning that two other companies had the right to manufacture the same commodity which Mr. Ball's company has a right to manufacture, so that his license, or the license of his company, was taken subject to the licenses which had been granted to two other companies.

Mr. BRACKEN. If I may answer, schedule C of the contract shows that there were four other companies which had the right to make jars.

Mr. Cox. Can you tell us while we are on that subject, how many companies there are today who are manufacturing fruit jars? It is true that Hazel-Atlas manufactures them.

Mr. BRACKEN. That is correct.

Mr. Cox. And Owens-Illinois.

Mr. BRACKEN. That is correct.

Mr. Cox. And the Kerr Glass Co.

Mr. BRACKEN. That is correct.

Mr. Cox. And the Reed Glass Co., do you know whether they manufacture fruit jars?

Mr. BALL. If I may answer, they manufacture jars and have sold them to go into the domestic trade but, as we understand it, they have no license for manufacturing those jars from the Hartford-Empire Co.

Mr. Cox. Do you know of any other companies that are today manufacturing fruit jars?

Mr. BALL. There are several companies that have manufactured so-called packers' jars, but they are making them so that they will seal with the regular domestic fruit jar cap, and in that way they get them into the market and displace the regular domestic jars, and that we consider unfair practice. It was supposed that we would have exclusive right to make the jars used for domestic canning without being encroached upon by jars like these packers' jars.

Mr. Cox. I would like to offer these letters.

(The letters referred to were marked collectively "Exhibit No. 148" and are included in the appendix on p. 791.)

Senator KING. The gentleman on your left, Mr. Ball, has just stated, if I understood him correctly, that your license was subject to prior licenses to four companies, is that correct?

Mr. BALL. Yes, sir.

Senator KING. Then your statement now that you had the exclusive right is not quite accurate, is it, if there were four other companies?

Mr. BALL. The exclusive right beyond the licenses that had been granted prior.

Mr. BRACKEN. That was called, as I remember, the residual rights.

Mr. COX. That is correct, and the reason there is now a discrepancy between the four companies that Mr. Bracken spoke of as having been in contract and the ones I named a moment ago as having a license today, is because one of the licenses which existed as of the date of the contract I understand has since expired.

Mr. COLLINS. One more question: Did you as a result of receiving a letter from Mr. Eldred take any steps to see that the General Glass Co. ceased to sell and distribute packers' ware for use as domestic fruit jars?

Mr. COLLINS. The fact of the matter is that I don't think we ever made any effort to sell packers' jars as domestic fruit jars.

Senator KING. And you got the \$100,000 without consideration?

Mr. COLLINS. Oh, no.

Senator KING. You surrendered the license to make those jars and I understood you just now that you didn't make any.

Mr. COLLINS. That's right; as domestic fruit jars. We made packers' jars, which is the thing Mr. Ball was complaining about in that letter.

Mr. COX. You were making fruit jars before you gave up the right to make them?

Mr. COLLINS. No; we never made them.

Mr. COX. So you got the \$100,000 for giving up the right to make a thing which you had never exercised.

Mr. COLLINS. Right.

Senator KING. It was a good trade, wasn't it? There are lots of potentialities, aren't there?

Mr. COLLINS. Right.

Mr. COX. Mr. Collins, I think for the time being that is all I shall want from you, but I shall want some testimony on another subject later on.

Senator KING. Did you regard the license which your company held as of any value?

Mr. COLLINS. Yes; I certainly did, otherwise I wouldn't probably have asked \$100,000 for it.

Senator KING. Although you never exercised the right the license gave?

Mr. COLLINS. Yes.

Senator KING. What part of the licenses, if there were more than one, or only one, that you held from the Hartford Co., did you reserve?

Mr. COLLINS. I reserved everything that we had in our license excepting the fruit jars, which I sold for \$100,000. It didn't affect any other part of my license.

Senator KING. By your disposing of that right did you diminish competition?

Mr. COLLINS. So far as I was concerned, there was no competition, because we had never made them.

Senator KING. Did you intend to?

Mr. COLLINS. Not at that time; no.

Senator KING. Were you in competition with any other licensees of the Hartford Co. at the time that you parted with this right?

Mr. COLLINS. Do you mean on fruit jars?

Senator KING. On anything.

Mr. COLLINS. Oh, yes.

Senator KING. What were you making, aside from fruit jars?

Mr. COLLINS. We made a general line of packers' ware of all types, narrow neck and wide mouth.

Senator KING. Does your company still continue in operation?

Mr. COLLINS. Right.

Senator KING. Making the same commodities?

Mr. COLLINS. Right.

Senator KING. Are you in competition with other companies?

Mr. COLLINS. Yes; with Owens-Illinois, Hazel-Atlas, and every company that is named on that board.

Senator KING. Is there competition among you?

Mr. COLLINS. Plenty.

Senator KING. No combination in restraint of trade; no agreement to fix prices?

Mr. COLLINS. No, sir.

Senator KING. Has there ever been?

Mr. COLLINS. No, sir.

Senator KING. Do you believe in a competitive system?

Mr. COLLINS. That is what we have lived under all our lifetime.

Senator KING. Have you had fierce competition or any competition in the market?

Mr. COLLINS. Yes; plenty of competition.

Mr. PATTERSON. Mr. Collins, with regard to that \$100,000, was there any other consideration besides that?

Mr. COLLINS. No.

Mr. PATTERSON. It wasn't \$100,000 plus?

Mr. COLLINS. It was \$100,000 for our fruit jars.

Mr. PATTERSON. And a clean bill of sale.

Mr. Cox. Mr. Ball, I might ask you this. Was it your understanding when you paid the money which you paid to Hartford as consideration for the license agreement that part of that money was to be used to buy back the fruit jar rights of the General Glass Co.?

Mr. BALL. We didn't know at that time what the Hartford-Empire would do with the amount that we paid. They exacted \$100,000 for the rights that they proposed to grant to us and they were to eliminate the competition that might come from these factories that had licenses, and by that we supposed that they would in some way make settlement with those companies. We did not know at that time how they would make those settlements.

Mr. Cox. You simply knew that with respect to the General Glass Co. they were going to get that right back—Hartford-Empire was going to get it back. You didn't know how or how much they were going to pay to get it back.

Mr. BALL. Yes, sir; that was our expectation, that they would have that license canceled in some way.

Senator KING. Did you know that Mr. Collins' company had a license?

Mr. BALL. Well, the General Glass Co. had a license at that time; yes.

Senator KING. Did you know it had not been producing under that license?

Mr. BALL. We knew they had not produced the domestic jars under that license, but we knew that they had the privilege of producing the jars, the domestic jars, under their license and we thought that we should have that canceled if we were to take out the license that we were proposing to take out and pay the amount of money that they wanted us to pay.

Senator KING. You were not extinguishing, then, an active competitor in the product to which you referred but a possible potential competitor?

Mr. BALL. Yes, sir.

The CHAIRMAN. Who paid you the \$100,000, Mr. Collins?

Mr. COLLINS. Hartford-Empire.

The CHAIRMAN. This was for the right which you have just testified you had never exercised and never intended to exercise?

Mr. COLLINS. We at least never had.

The CHAIRMAN. But you might have exercised it?

Mr. COLLINS. That is right.

The CHAIRMAN. What did Hartford think it was getting for the \$100,000?

Mr. COLLINS. Rights to make our fruit jars.

The CHAIRMAN. Sort of eliminating you for the period of the contract or for all time from this field. Is that right?

Mr. COLLINS. That is right.

Senator KING. How many years did the contract run from the date of your disposition of it, accepting the \$100,000?

Mr. COLLINS. Well, I think the contract or license would run the term of the patent of the Hartford-Empire.

Senator KING. You had obtained the license from the Hartford-Empire for the life of their patent in this particular commodity?

Mr. COLLINS. Yes.

Senator KING. And though you hadn't exercised the right granted under the license, you parted with that right, you surrendered the license which you had received for \$100,000.

Mr. COLLINS. That is right.

Mr. COX. I have finished with Mr. Collins if all the other members of the committee have.

The CHAIRMAN. If there are no questions, Mr. Collins, you may be excused.

(Witness Collins was excused.)

Mr. COX. I should like to ask either Mr. Ball or Mr. Bracken some questions about the price ranges for domestic fruit jars shown by your price list. Do you have a price list?

Mr. BRACKEN. Yes, sir.

Mr. COX. I wonder now if you will follow me while I ask you some questions about those price ranges. I am going to speak each time

in terms of price per gross. You have a list there that shows the prices, beginning in 1922?

Mr. BRACKEN. Yes.

Mr. BALL. On fruit jars?

Mr. COX. On fruit jars.

Mr. BALL. We quoted prices from year to year, making up our prices, based on cost and conditions and investments that we were making in the fruit jars, but we had no regular fruit jar price list to cover a term of years such as they have on some other bottles.

Mr. COX. Now, is it true, Mr. Ball, can you tell whether it is true from your material there that the price in 1922 for domestic fruit jars per gross was \$7.50, the quart size jar?

Mr. BALL. Yes, sir.

Mr. COX. And it remains \$7.50 in 1923 and in 1924?

Mr. BALL. We quoted what was called our base price, and at times when we wanted to urge shipments early in order to relieve our storage capacity, we made a reduction for earlier shipments, and some of these prices are quoted as a base price, f. o. b. factory, with the understanding that if they would take the jars out early, there would be a reduction from that price.

Mr. COX. I see. Well, now can we from this point on take the base price with the understanding that there were certain deviations from that price in the case of shipments made before the seasonal shipment period?

Mr. BALL. Yes.

Mr. COX. So that from 1922 to 1924 the price per gross for the perfect mason quart jars was \$7.50. Is that right?

Mr. BALL. What is the question?

Mr. COX. I asked you if the base price didn't remain the same from 1922 to 1924, the price being \$7.50 per gross.

Mr. BALL. The net price for 1922, after the deductions were figured off, was \$7 a gross; in 1923 it was \$7 per gross; in 1924 it was \$7 per gross; in 1925 it was \$5.85 per gross; in 1926 it was \$7.25 per gross; in 1927, \$7.50 per gross.

Mr. COX. Perhaps just at that point, to speed this up, if you will stop there and examine those prices between 1927 and 1933 and tell me whether there was any change in that period, and, if so, what the change was and when it occurred.

Mr. BALL. In 1932 it was \$7.27 per gross; in 1933, \$6.70 per gross. Then in 1930 it was \$7.27 per gross; in 1933, \$6.70 per gross.

Mr. COX. Now, for the sake of the record, you had better tell us what the price was from 1927 to 1930. Did it remain constant for that time?

Mr. BALL. In 1927, '28, and '29 it was \$7.50 per gross. In 1931 it was—no, 1930 it was \$7.27 per gross; 1932, \$6.70 per gross; 1934, \$7.29 per gross.

Mr. COX. Do you want to take those prices down to the present time that you have them? Just have Mr. Bracken read them, if you will.

Mr. BRACKEN. In 1933, \$6.70; 1934, \$7.29; 1935, \$7.05; 1936, \$5.56; 1937, \$6.79; and in 1938, \$6.79.

Mr. COX. That is right.

Mr. BRACKEN. Those, you understand, are on the quart mason.

Mr. COX. That is the quart mason. Is that the base price you were speaking about before?

Mr. BALL. That is the net price after deducting the allowances for the earlier shipments.

Mr. COX. Now, can you tell us what the base price was for people who didn't get those deductions?

Mr. BRACKEN. That is the base price, after taking the 2 percent cash discount.

Mr. COX. All right, that is as much as I want. Now, Mr. Ball, I want to ask you some more questions about licensing arrangements with the Hartford-Empire. Was it your belief that, when that contract was made, afterward Hartford-Empire was to give you any protection against persons who were manufacturing fruit jars and selling them at cut prices? Do you understand my question?

Mr. BALL. No, sir; not those who had the right to manufacture fruit jars at all. There was no arrangement as to the price that the licensee should charge, but they did agree to restrict those who had no license from manufacturing jars and selling them at any price.

Mr. COX. And you, from time to time, did you not, complained to Hartford-Empire about the manufacture of fruit jars by persons who had no license to do so, and the sale of those fruit jars at cut prices in competition with your own?

Mr. BALL. Yes, sir; we did.

Mr. BRACKEN. I think we should say not the making of fruit jars but the making of these plain jars which went into the domestic trade.

Mr. BALL. Well, making jars that would sell with the regular domestic cap, but calling them packers' jars when in reality they were sold in the fruit-jar trade as domestic jars.

Mr. COX. Do you remember complaining to Mr. Goodwin Smith in 1935 that the Glenshaw Co. was indulging in that practice?

Mr. BALL. I think we did.

Mr. COX. And do you remember complaining in 1935 to Mr. Smith that the Reed Co. was also indulging in that practice?

Mr. BALL. I think we did.

Senator KING. Were they licensees?

Mr. BALL. No, sir.

Senator KING. You said they were operating in violation of the patent rights of the company and in violation of your contract with the company as a licensee.

Mr. BALL. Yes; in violation of our contract with the Hartford-Empire Co.

Mr. COX. Mr. Ball, I think perhaps your recollection may be at fault about the Glenshaw Co. It was a licensee.

Mr. McCALLISTER. Glenshaw was a licensee.

Mr. BALL. Not to make fruit jars.

Mr. COX. The Reed Co. was not a licensee at all.

Mr. McCALLISTER. And isn't now.

Mr. COX. In the case of the Reed Co. you offered to assist in suing them for infringement of the Hartford patents, did you not?

Mr. BALL. I am not sure about that, whether we offered to assist them or not.

Senator KING. Do you mean by a financial contribution or by furnishing evidence, or both?

Mr. Cox. I will find that out, Senator. I will ask Mr. Ball to examine this copy of a letter which was written to him by Mr. R. D. Brown, of the Hartford-Empire, dated May 13, 1935, and then I shall ask him if that refreshes his recollection.

Mr. BALL. Yes, sir; that is a letter addressed to me by Mr. Brown, and the Reed Glass Co. was making jars that were going into the domestic trade and, as we understood it, in violation of the Hartford-Empire patent and, in view of the contract that we had with the Hartford-Empire Co., we considered that it was their duty to see that that violation of our contract with the Hartford-Empire was discontinued.

Mr. Cox. Mr. Ball, what I want to ask you particularly about this matter is this: The letter begins [reading]:

DEAR MR. BALL: On my return to Hartford, Mr. Smith has handed me your letter of May 6 with regard to the Reed suit, in which you suggest that we discuss the situation with Mr. McCallister. We shall be very glad, indeed, to do this, and I appreciate very much your suggestion and your offer of cooperation in this matter.

In the hope that I can elicit the information which Senator King was asking for, I ask you whether that refreshes your recollection as to the general character of the assistance and cooperation which you offered to give Hartford-Empire in this connection.

Mr. BALL. We were willing to give them any assistance we could properly and within the law and reason.

Senator KING. Did you give them any assistance, and if so, what was the character of it?

Mr. BALL. If they wanted any information that we could give them we were glad to give it.

Mr. McCALLISTER. He asked you if you did give the assistance.

Mr. BALL. I doubt if we ever did.

Mr. BRACKEN. We did not.

Mr. BALL. I don't recall that we were called upon to give any assistance.

Mr. Cox. Mr. Ball, I am going to read to you the first paragraph of a copy of a letter which purports to have been sent by you to Mr. Goodwin Smith, of the Hartford-Empire Co., dated May 3, 1933 [reading from "Exhibit No. 149"]:

Since writing to you yesterday regarding Three Rivers Glass Company I have been reliably informed that a Sherman, Texas, jobber is now offering to sell to the retail trade fruit jars for domestic use to be manufactured by the Three Rivers Glass Company under the brand name "Crack Shot." The price at which they are offering these jars is 65 cents per gross less than the same jobber is offering "Ball Jars." This is disturbing the other jobbing customers and they want to know what we are going to do about it.

I ask you if that is a letter which, in fact, you wrote to Mr. Goodwin Smith.

Mr. BALL. I believe it is.

Mr. Cox. I should like to offer this letter.

The CHAIRMAN. The letter may be admitted.

(The letter referred to was marked "Exhibit No. 149" and is included in the appendix on p. 792.)

Mr. Cox. Mr. Ball, are you using any Hartford equipment in your plants today?

Mr. BALL. We are using the gob-feed feeders that we invented and built and installed, and under the Hartford-Empire license we have

the right to either continue to use the feeders that we had in use at that time and installed, or the Hartford-Empire feeder, and so far we have not installed any of the Hartford-Empire feeders.

Mr. COX. You are using the feeder you always used, but you are paying royalties to Hartford-Empire on your production on those feeders?

Mr. BALL. On those feeders.

Mr. COX. One more question, Mr. Ball. This morning I asked you whether you knew, when you made your agreement with Hartford-Empire, that the royalties which you were paying were being divided with Owens-Illinois and Hazel-Atlas, and you answered that you did not.¹ You know, of course, now, that royalties which you are paying now are still being divided with Hazel-Atlas, do you not?

Mr. BALL. So I understand, from the evidence that has been given.

Mr. COX. Now, I want to ask you, Mr. Ball, whether in your opinion that situation is a healthy situation from the competitive point of view, so far as you are concerned? Do you like it?

Mr. BALL. We don't like it very well.

Mr. COX. I think I have finished with Mr. Ball.

Senator KING. You mentioned that you were operating the gob machine. Is that the machine which the Hartford Co. contended was an infringement upon their patent?

Mr. BALL. They contended that it was an infringement on their patent, but up to the time of the decision in the Hazel-Atlas suit, decided by Judge Buffington, we were advised by our patent attorneys and other attorneys that it was not an infringement in their opinion, but when that decision was made it seemed to cover the gob feed that we were using, and rather than face a law suit and the annoyance and trouble and expense connected with it, we decided to take out a license, provided we could get one on satisfactory terms, and in that way we negotiated with the Hartford-Empire Co.

Senator KING. At any rate the Hartford-Empire Co. contended that you had infringed their patent and the litigation to which you refer culminated in the support of the contention of the Hartford-Empire Co., and you accepted the decision of the court and took a license from the Empire Co.?

Mr. McCALLISTER. They themselves were not sued.

Senator KING. I understand that. They were not party to that suit, but there was an adjudication sustaining the validity of the Empire patent.

Mr. BRACKEN. There were four suits in all.

Mr. BALL. There were a number of suits that were pending at the same time. Some I guess had been decided, and this was one of them. It looked to us that it would be better and cheaper, perhaps, for us to take out a license than to fight a patent lawsuit and so we took it out.

Mr. McCALLISTER. You understand I was in favor of fighting.

The CHAIRMAN. The attorney wants it understood that he stood by his original opinion.

Mr. McCALLISTER. Absolutely.

¹ Supra. p. 560.

Mr. BALL. I might say that Mr. McCallister was not in on the negotiations that we had with the Hartford-Empire Co. We had two of our regular attorneys, Mr. Hornbrook, of Indianapolis, who has since died, and Mr. Brady, our regular attorney, who has since died. They two joined with me in going to New York to draw up the agreement with the Hartford-Empire Co.

Senator KING. I have nothing further.

The CHAIRMAN. This machine that you were using was of your own development?

Mr. BALL. Yes, sir.

The CHAIRMAN. What was the name of that machine?

Mr. BALL. The difference between that machine and the Hartford-Empire machine is the fact that they use what is known as a solid plunger that goes into the glass and pushes the glass through the aperture and then withdraws and draws the glass up. We had one that embodied a tube in which we inserted air pressure to force the glass down and then vacuum to draw the glass back, and in that way we got the same result that they are getting with the solid plunger, but using air pressure in place of a solid plunger.

The CHAIRMAN. You had been using this device of yours—

Mr. BALL. What is that?

The CHAIRMAN. You had been using this device of yours for how long a period?

Mr. BALL. Oh—

Mr. McCallister (interposing). I would say from 1920 on.

Mr. BALL. I think it was 1929, about there, we began using it. Before using the gob feed we had used a flowing stream. In fact, if you wish, I will go back to the point that we started in the glass business, using the tools that were used by the Egyptians, 2,000 years ago.

The CHAIRMAN. I don't think that will be necessary.

Mr. BALL. The hand blowpipe and the hand molds, and we used those up to 1886 when we invented the first practical press and blow machine for making glass jars.

The CHAIRMAN. I wanted to make clear in my own mind that I understood you correctly in that you paid this \$400,000 not because you had any conviction that the process which you were using was an infringement upon the Hartford patent, but that you wanted to get rid of the nuisance of lawsuits and go on with the manufacturing of your glass product. Is that correct?

Mr. BALL. Well, taking into consideration the decision of the court, Judge Buffington, it would seem as though we did infringe, but that was something that we were not, of course, sure of.

The CHAIRMAN. And as a consideration for taking out the license, you wanted to be assured that no new licensees would be permitted to enter the field under the Hartford patent to compete with you.

Mr. BALL. Yes, sir.

Senator KING. I want to ask one question if I may. You gave in answer to questions by Mr. Cox the base prices for a number of years from '22 on. How did those base prices, or the prices which ultimately were paid by the consumer, compare with the prices paid by consumers for other fruit jars manufactured under similar patents. Did you charge more or did you charge less? Was there any

competition between you and other manufacturers of the same kind of jars?

Mr. BALL. Really, I don't know what jars made by other manufacturers were sold at.

Senator KING. Didn't you try to find out when you were fixing your prices for the vending of your commodity what the market price was for a similar one?

Mr. BALL. We made our price on the Ball perfect mason jar. We began in 1880.

Senator KING. If you will pardon me, all I am interested in knowing is whether or not there was any effort by you and others making prices to combine for the fixing of prices, or was there competition between you and them?

Mr. BALL. Not so very much. Our prices were made on the Ball perfect mason jar. We started nearly 50 years ago to build up a demand for that particular brand, and by making jars and inspecting them as perfectly as possible, we had created a demand so that they were called for in practically all States of the Union.

Senator KING. So you had a clientele of your own and you fixed your own price without reference to anybody else.

Mr. BALL. Yes, sir. When it came time for us to quote prices we took the cost and the investment and the risk and the conditions into consideration and made our price, and quoted it broadcast to all the jobbing customers of the United States.

Senator KING. Did the production of fruit in a given year, and the price of sugar, and the economic conditions have anything to do with the fixing of prices, or did you fix your base without reference to those considerations or factors?

Mr. BALL. We took into consideration more than anything else the cost and carrying charge and the investment.

Senator KING. Plus a reasonable profit.

Mr. BALL. With a reasonable profit.

The CHAIRMAN. If there are no other questions, the witnesses may be excused. We thank you, Mr. Ball and Mr. Bracken and Mr. McCallister.

(Mr. Ball, Mr. Bracken, and Mr. McCallister were excused.)

Mr. Cox. Mr. Underwood is going to be the next witness.

The CHAIRMAN. Mr. Underwood, do you solemnly swear that the testimony you are about to give in this proceeding shall be the truth, the whole truth, and nothing but the truth, so help you, God?

Mr. UNDERWOOD. I do.

TESTIMONY OF R. R. UNDERWOOD, PRESIDENT, KNOX GLASS ASSOCIATES, OIL CITY, PA.

Mr. Cox. Mr. Underwood, will you give the reporter your name and address and your present occupation.

Mr. UNDERWOOD. R. R. Underwood, president, Knox Glass Associates, Oil City, Pa.; residence, Knox, Pa.

Mr. Cox. Just briefly tell us what Knox Glass Associates is.

Mr. UNDERWOOD. Knox Glass Associates is a corporation held equally by five of our associated companies, located in Pennsylvania.

Mr. Cox. The five associated companies are companies which produce glass containers; is that right?

Mr. UNDERWOOD. Yes, sir.

Mr. COX. Can you tell what they are?

Mr. UNDERWOOD. Knox Glass Bottle Co., Wightman Bottle & Glass Manufacturing Co., Pennsylvania Bottle Co., Marienville Glass Co., and Oil City Glass Bottle Co.

Senator KING. All subsidiaries?

Mr. UNDERWOOD. No; they are rather associated companies.

Senator KING. How many in all?

Mr. UNDERWOOD. Five in Pennsylvania, and we have two associated with us, one in Jersey City, N. J., known as the Metro Glass Bottle Co., and one in Jackson, Miss., known as the Knox Glass Bottle Co. of Mississippi.

Mr. COX. Is Knox Glass Associates a licensee of Hartford-Empire?

Mr. UNDERWOOD. No; Knox Glass Associates is not a licensee of Hartford, but the other companies are.

Mr. COX. Each of what you call the associated companies is a licensee of Hartford-Empire.

Mr. UNDERWOOD. Yes, sir.

Mr. COX. Just tell us briefly what functions Knox Glass Associates perform for the associated companies, so the committee will understand the nature of your business organization.

Mr. UNDERWOOD. I formed the Knox Glass Associates, Inc., January 1, 1935, for the purpose of administering the sale as well as engineering, and so forth, and management for the five companies located in Pennsylvania, as well as the companies located in Jersey City and Jackson, Miss.

Senator KING. Is that a holding company, then?

Mr. UNDERWOOD. No; it is not a holding company; rather it is held by the five companies.

Mr. COX. Stock of Knox Glass Associates is held by these companies which are engaged in producing glass containers.

Mr. UNDERWOOD. That is right.

Mr. COX. And it performs certain sales services and certain engineering services for the companies?

Mr. UNDERWOOD. And business administration.

Senator KING. Did it have any capital?

Mr. UNDERWOOD. None other than is held in equal amounts by the five companies located in Pennsylvania, and a nominal capital.

Mr. COX. How long have you been in the glass business?

Mr. UNDERWOOD. Since 1914.

The CHAIRMAN. May I interrupt to inquire what common ownership there is among the five associated companies?

Mr. UNDERWOOD. The Knox Glass Bottle Co. of Knox, formed some time in 1917, has a stock interest in each one of these companies that I have named, ranging from possibly 35 percent ownership to wholly owned subsidiary in the case of Knox Glass of Mississippi.

The CHAIRMAN. And how about the ownership in the Jersey company?

Mr. UNDERWOOD. It has a stock ownership in the Metro Glass of Jersey in the amount of 33 $\frac{1}{3}$ percent.

The CHAIRMAN. So that the Knox Co. of Knox is really the parent company of the various associated companies.

Mr. UNDERWOOD. That is right.

The CHAIRMAN. And the Knox Glass Associates is the agency of all of the companies to perform these services which you have described.

Mr. UNDERWOOD. That is right, with the exception of the company in Jersey City which administers its own sale; likewise in the case of the Mississippi corporation.

The CHAIRMAN. With the exception of those two companies, all of the others are chiefly confined to the manufacturing of glass.

Mr. UNDERWOOD. That is right.

The CHAIRMAN. And they turn their product over to this other company for sale.

Mr. UNDERWOOD. That is right, sir.

Mr. Cox. Mr. Underwood, is the Knox Glass Co. the company that you first became connected with?

Mr. UNDERWOOD. Knox Glass Bottle Co.

Mr. Cox. How long have these companies been licensees of Hartford-Empire?

Mr. UNDERWOOD. I should think since August 1932.

Mr. Cox. Before that time, what kind of glassmaking machinery were the companies using?

Mr. UNDERWOOD. We employed both what is known as the Miller feeder and the O'Neill feeder.

Mr. Cox. Were those both gob feeders?

Mr. UNDERWOOD. Yes, sir.

Senator KING. Was not the Miller patent held to be invalid, or was not its validity challenged by some competing companies?

Mr. UNDERWOOD. That is right, sir. It was held to be invalid by Judge Buffington of the third circuit, Philadelphia.

Mr. Cox. I believe that was not the Miller patent that was held to be invalid in the third circuit; it was the Hazel patent. I believe the Miller patent was adjudicated in the Cincinnati circuit.

The CHAIRMAN. Wasn't it negotiated out?

Mr. Cox. It never was declared invalid.

The CHAIRMAN. It was purchased out by the Hartford-Empire Co., because the testimony was given here that the attorney for Miller threatened the Hartford-Empire, and the Ball Co., as I recall, that the patent would be kept in the Patent Office by interference for 5 years, and it was to settle that litigation that an agreement was reached. Is that your recollection?

Mr. UNDERWOOD. I believe, Senator, that the Lamb Glass Co. of Mount Vernon, Ohio, who operated what was known as the Miller feeder, was sued by the Hartford Co. in the District Court of Columbus, and I believe that that patent was adjudicated in the circuit court in Cincinnati, that particular Miller patent.

Senator KING. To be valid or invalid, which?

Mr. UNDERWOOD. I believe that was held, if I recall correctly, to be invalid as to what was known as phase changing in the patent.

Mr. Cox. Do you recall the purchase of the business of the William J. Miller Engineering Co. or the patent rights of that company, I should say, by Hartford-Empire?

Mr. UNDERWOOD. Yes; by Hartford-Empire; I recall distinctly the taking of the patents of William J. Miller, who was the proprietor of the Miller Engineering Co., by the Hartford Co.

Mr. Cox. At that time you were connected with the Knox Glass Bottle Co.?

Mr. UNDERWOOD. Yes, sir.

Mr. Cox. Was it using a William Miller feeder?

Mr. UNDERWOOD. Yes, sir.

Mr. Cox. We from time to time in this hearing have had references to what has been called the Miller Users' Defense Association. Will you tell us briefly what that was and how it came into existence and what it did?

Mr. UNDERWOOD. At the time that the Hartford-Empire Co. purchased the patents of William J. Miller, a number of us smaller manufacturers were employing the Miller feeding device.

Mr. Cox. I beg your pardon, but you had both those feeders outright?

Mr. UNDERWOOD. That is right.

Mr. Cox. Not under license; they were your property?

Mr. UNDERWOOD. Purchased them from the Miller Engineering Co. specifically. After the purchase of the patents by the Hartford Co., we decided that possibly William J. Miller would not give a sufficient support to their defense and, not being able individually or at least a number of us individually able financially to prosecute the defense, we formed what was known as the Miller Users' organization and employed counsel and defended the patents to as great an extent as we thought it was practical to do, giving consideration to the financial obligations incurred thereby.

Mr. Cox. I understand by that, then, that you did contribute financially to the defense of certain litigation.

Mr. UNDERWOOD. That is right.

Mr. Cox. Which involved the question as to whether or not the use of those patents infringed the Hartford patents.

Mr. UNDERWOOD. That is right.

Senator KING. Hartford was the other side of the litigation.

Mr. UNDERWOOD. That is right.

Mr. Cox. Could you tell us how long that litigation lasted?

Mr. UNDERWOOD. I believe that we conducted that litigation from somewhere around 1927 or 1928 until the time that the Hazel settled their suit with the Hartford Co.

Mr. Cox. And after the settlement of the Hazel-Atlas suit did the association continue to be active?

Mr. UNDERWOOD. Subsequent to the settlement of the Hazel-Atlas suit the association substantially disintegrated, I believe.

Mr. Cox. Some of the members took licenses of Hartford?

Mr. UNDERWOOD. That is right, and we were those who took the license.

Mr. Cox. There is one more question I want to ask. Can you tell us approximately how expensive this litigation was, conducted with the Hartford-Empire? I am speaking now of the whole group which belonged to the Miller Users' Defense Association.

Mr. UNDERWOOD. Our records indicate that a total expenditure of some approximately \$130,000 to \$140,000 was expended in the defense or the prosecution of that defense.

Mr. Cox. That was for the whole period of time?

Mr. UNDERWOOD. That was for the group.

Mr. Cox. Most of those companies you said a moment ago were small companies; is that correct?

Mr. UNDERWOOD. Yes; I believe that most of them would be considered the minor companies of the industry.

Mr. Cox. Now, I want you to tell us briefly—

Senator KING (interposing). Could I ask one question? Were they manufacturing anything other than the kind of glass that has been referred to in these hearings?

Mr. UNDERWOOD. Most of them, Senator, were manufacturing a general line.

Senator KING. Not plate glass?

Mr. UNDERWOOD. No.

Senator KING. Window glass?

Mr. UNDERWOOD. All glass containers.

Senator KING. I see.

Mr. Cox. Will you tell us, Mr. Underwood, the circumstances under which you took a license from Hartford-Empire? I am speaking now of you in your connection with the Knox Glass Bottle Co.

Mr. UNDERWOOD. Of course. We were notified by the Hartford Co. that we were infringing their patents, and we were in hopes that we could continue defending until the patents would be adjudicated. We found, sometime late in 1929 or 1930, that it was impractical for our company on account of financial reasons to prosecute the defense further, and we were invited to discuss the matter with the Hartford Co. early in 1932, I believe, and as a result of that discussion—

Mr. Cox (interposing). Tell us about that invitation, Mr. Underwood. You say you were invited. Tell us what happened.

Mr. UNDERWOOD. Mr. Goodwin Smith, president of the Hartford-Empire Co., invited me to Hartford early in August 1932 to confer with him in connection with the patent situation. I met Mr. Smith in his office at Hartford in conjunction with some of his staff from his legal department.

Mr. Cox. Did you have a lawyer?

Mr. UNDERWOOD. Yes. I beg your pardon?

Mr. Cox. I said, "Did you have a lawyer?"

Mr. UNDERWOOD. No; I didn't have a lawyer with me. I don't know whether that may be fortunate or unfortunate. Nevertheless, I met Mr. Smith and his staff and, of course, he placed before me a proposition which it was impossible for us to accept at that time, and he was so advised that on account of the financial obligation our companies would be obliged to accept in the event we met his first thought on the subject—

Mr. Cox (interposing). What was that proposition?

Mr. UNDERWOOD. I believe that the Hartford Co. requested us to compile a memorandum of royalties due them from the date of issue of the Peiler patent sometime in 1925 to date. We did; and the result of that was simply that we were indebted to them on account of that record so compiled, a sum equal to about \$630,000.

Mr. Cox. What was the capitalization of your company at that time?

Mr. UNDERWOOD. Somewhere, possibly, at that time—I believe at that particular time our company was probably capitalized at a million dollars, with probably half of that amount outstanding, or less.

Of course, I advised Mr. Smith that we couldn't meet that situation, and then we reconvened at a subsequent conference, and as a result of that we did effect a settlement with the Hartford Co. by paying them a certain amount and accepting licenses for 25 of their units.

Mr. COX. How much did you have to pay, Mr. Underwood?

Mr. UNDERWOOD. We paid Hartford \$100,000.

Mr. COX. Now, was that license you were given an unrestricted license?

Mr. UNDERWOOD. No; we were restricted with respect to a limited number of milk bottles, I believe 75,000 gross.

Mr. COX. How many milk bottles had you been making before that?

Mr. UNDERWOOD. Approximately 100,000 to 150,000 per annum.

Mr. COX. You asked for more milk bottles?

Mr. UNDERWOOD. That's right.

Mr. COX. But you didn't get them?

Mr. UNDERWOOD. We didn't get them, and I believe the fruit jar was excluded from that particular license, and all carbonated-beverage bottles.

Mr. COX. Were any other restrictions contained in the license so far as number and quantities were concerned?

Mr. UNDERWOOD. We were restricted to the use of 25 feeding devices.

Mr. COX. And that, of course, restricted the amount of ware you could produce?

Mr. UNDERWOOD. That's right.

Mr. COX. Could you, Mr. Underwood, tell me whether at any time after that you attempted to develop any other kind of glassmaking machinery that you could use free from license of the Hartford-Empire?

Mr. UNDERWOOD. Yes. Sometime in 1927 I joined hands with Frank O'Neill, of Toledo, Ohio, operating the O'Neill Machine Co., and as a result of that we developed in our plant what was known as the Knox-O'Neill suction machine.

Mr. COX. What did you use that machine for?

Mr. UNDERWOOD. The manufacturing of a miscellaneous or general line of glass.

Mr. COX. I meant to ask you a moment ago, Mr. Underwood, whether, before you took a license from Hartford-Empire, you manufactured any milk bottles and sold them.

Mr. UNDERWOOD. Yes; ranging from 100,000 to about 150,000 gross per annum.

Mr. COX. Was that a considerable part of your business?

Mr. UNDERWOOD. That was a very substantial part of our business, profit-wise.

Senator KING. You are speaking of the four or five companies, now?

Mr. UNDERWOOD. Yes.

Mr. COX. Did you, before you took the license, manufacture any fruit jars?

Mr. UNDERWOOD. Yes; we manufactured what was known as the Knox fruit jar.

Mr. Cox. And did you manufacture, before you took a license, any carbonated-beverage bottles?

Mr. UNDERWOOD. Not to any great extent. Our manufacture of carbonated-beverage bottles was very limited.

Mr. COX. You manufactured some, but not many?

Mr. UNDERWOOD. That's right.

Mr. COX. And after you took the license you ceased to manufacture carbonated-beverage bottles and fruit jars altogether?

Mr. UNDERWOOD. We ceased manufacturing carbonated-beverage bottles except that Hartford granted to us the right to manufacture a small quantity of carbonated-beverage bottles for an account in Cleveland. We did not manufacture subsequent to our license with Hartford any more fruit jars on their equipment. We did, however, manufacture on the Knox suction machine.

Mr. Cox. That was the machine you were speaking of a moment ago which you developed with Mr. O'Neill? Is that correct?

Mr. UNDERWOOD. That's right.

Mr. COX. You manufactured fruit jars on that machine, you say. How long did you continue to manufacture those fruit jars?

Mr. UNDERWOOD. I believe we continued manufacturing fruit jars on our Knox-O'Neill suction machine until sometime early in 1933.

Mr. COX. What happened then?

Mr. UNDERWOOD. We sold our fruit-jar business to Ball Bros.

Mr. COX. Why did you do that, Mr. Underwood? Hadn't it been profitable?

Mr. UNDERWOOD. Yes; fruit jars were a very profitable line to us. However, we were approached by Hartford with respect to our Knox-O'Neill machine being a possible infringement on certain patents that had issued to them or for which they had applications filed, and in addition to that they questioned our position with reference to manufacturing fruit jars on any device that we had operating at that time. Rather than to develop a situation which we were not in position to defend, and didn't feel that we should at that time, we sold the business to the Ball Bros. for what we thought was a fair consideration.

Mr. COX. What was that?

Mr. UNDERWOOD. I think Ball Bros. paid us \$100,000, if I remember rightly—\$85,000 to \$100,000.

Mr. COX. Was this early in 1933?

Mr. UNDERWOOD. I believe it was. I believe it was some time during February or March 1933.

The CHAIRMAN. How did you happen to sell to Ball Bros.?

Mr. UNDERWOOD. We were contacted by Mr. George Ball, I believe, in connection with the matter, or it was discussed in some manner or other that we came to know that they were interested in purchasing our fruit-jar business.

The CHAIRMAN. Through whom did you come to know it?

Mr. UNDERWOOD. I don't recall distinctly whether it was a contact made by Mr. George Ball or the Hartford Co. I don't recall just how that contact was made.

The CHAIRMAN. When the Hartford Co. approached you with respect to the manufacture of fruit jars, did it through its representative make any representation that you were competing with Ball Bros.?

Mr. UNDERWOOD. Yes; the Hartford Co., in their contact with me, advised that in their opinion the machine on which we were making these fruit jars infringed some of their patents.

The CHAIRMAN. Some of whose patents?

Mr. UNDERWOOD. Some of Hartford's patents, and they were particularly interested in the fact that we were manufacturing fruit jars on that machine and, of course, sooner or later that matter would necessarily be adjudicated, I knew.

The CHAIRMAN. Then was it suggested by the emissary of Hartford that you should sell to Ball?

Mr. UNDERWOOD. No; I don't know that it was. I think Hartford simply notified me that in their opinion we were restricted with respect to our feeder rights that we had under them, that we shouldn't manufacture under our feeder rights, and in addition to that, that no doubt their patents read on our vacuum machine.

Mr. Cox. Did you ask them for a license under their suction patents to manufacture fruit jars?

Mr. UNDERWOOD. No; I don't believe I did.

The CHAIRMAN. Did you seek out Ball yourself?

Mr. UNDERWOOD. I don't recall, Senator, how that contact was made, whether Hartford contacted me, whether it was by George Ball, or how the contact was made. I don't recall the incident as to how the situation was handled, but I know we were manufacturing a substantial quantity of fruit jars and we were very happy with the business.

Mr. Cox. What happened to the suction machines? Did you continue to manufacture anything else on them after you stopped manufacturing fruit jars?

Mr. UNDERWOOD. We continued the Knox-O'Neill vacuum machine, I believe, about eight units in production, until some time during 1933, without license from the Hartford-Empire.

Mr. Cox. What happened then?

Mr. UNDERWOOD. Mr. Smith advised me, some time I believe during 1933, that the Knox-O'Neill machine had infringed certain of their patents, and it was now time that we should get together and discuss the situation. As a result of that I met Mr. Smith, I believe in June or possibly in July of 1933, if my memory serves me correctly, to discuss that situation. And, of course, as a result of that discussion, we arranged to have our respective patent counsel get together, which they did, and our counsel advised us that it was possibly a 50-50 break as to whether we infringed the patents they alleged we were infringing, and then again as a result of that, of course, I thought it best not to involve our company further in defense, and we took a license for the suction machine from Hartford, and they purchased the equipment from us at some price satisfactory to both organizations.

Mr. ARNOLD. Did the greater resources of Hartford have anything to do with your making that decision not to take up the 50-50 fight?

Mr. UNDERWOOD. I would say that that has always been an influence in the life of our company, patentwise.

Mr. ARNOLD. You felt that they could continue the fight longer than you could?

Mr. UNDERWOOD. That's right.

Mr. ARNOLD. And that resources and persistence and an army of experts and counsel are as important in a patent fight as they are in any other kind of war?

Mr. UNDERWOOD. That's right. My file indicates that.

Mr. COX. Mr. Underwood, did you continue to manufacture milk bottles after you took the Hartford license?

Mr. UNDERWOOD. Yes. I apprised Hartford of the fact that it would be impossible for us to discontinue forthwith the manufacture of milk bottles and they kindly consented to permit us to continue manufacturing our previous quantity for a period, I believe, of 4 or 5 months. Then they requested us, at the close of that period, to reduce our production to 75,000 gross per year, which was the amount they finally allotted to us under our license.

Mr. COX. Did you continue to produce thereafter 75,000 gross?

Mr. UNDERWOOD. For possibly a few months only. We found that that quantity, for our organization and our equipment, was impractical.

Mr. COX. In other words, you could, from the point of view of profit, manufacture and sell successfully 100,000 or 150,000 gross, but if you were limited to 75,000 gross you couldn't do it?

Mr. UNDERWOOD. That is right.

Mr. COX. What did you do, then, with the milk-bottle part of your business?

Mr. UNDERWOOD. Sometime in December 1932, when I realized that it was impractical for our company to continue manufacturing a limited quantity in the amount of 75,000 gross of milk bottles per annum, I contacted Mr. Mandeville, of the Thatcher Manufacturing Co., and asked him if he would be interested in purchasing our milk-bottle business, that is, the machinery, good will, and so on, and so forth, and in the event that he would make the purchase, that we would go out of the business. He told me promptly that they might be interested in that, and as a result of our conference we sold our milk-bottle rights, that is, the right to make 75,000 gross of milk bottles, together with all machinery, molds, and equipment incident to the manufacturing of milk bottles, to the Thatcher Manufacturing Co., and I believe that sale was made in late 1932, in December.

Mr. COX. How did you happen to go to Mr. Mandeville, of the Thatcher Co.?

Mr. UNDERWOOD. Well, the reason I contacted Mr. Mandeville is because the Thatcher Manufacturing Co. were the leaders in this particular field, and I thought that if anyone would be interested in handling our milk-bottle—the residue of our milk-bottle—rights, Mr. Mandeville would be interested, the Thatcher Co. would be interested. It was a natural consequence of the situation.

Mr. COX. Because you knew it was probably the largest manufacturer of milk bottles in the country?

Mr. UNDERWOOD. That's right.

Senator KING. May I ask, did your company manufacture up to that time anything besides milk bottles? You have mentioned one product.

Mr. UNDERWOOD. We manufactured at that time a general line of all glass containers except the items that I referred to, such as carbonated-beverage bottles, and so on.

Mr. Cox. Now, Mr. Underwood, in your opinion if today you had a right under your license to manufacture fruit jars, could you manufacture and sell those fruit jars in the market at a profit?

Mr. UNDERWOOD. I would say, at the present market levels, volume-wise, insofar as fruit jars is concerned, no doubt a profit could be made on a limited quantity only.

Mr. Cox. But you could sell a limited quantity of fruit jars, you think, at a profit?

Mr. UNDERWOOD. That's right.

The CHAIRMAN. Why do you say a "limited quantity"?

Mr. UNDERWOOD. Because the domestic fruit jar, the volume on the domestic fruit jar, in our industry is very small compared with some of our other wide-mouth lines, such as Mr. Ball referred to some few moments ago.

The CHAIRMAN. What I had in mind was whether or not, in your judgment, you thought it would be a limited quantity because it would be limited to an area around your plants, or something of that kind.

Mr. UNDERWOOD. No, no. I am speaking Nation-wide.

Senator KING. Has that industry increased in these last few years?

Mr. UNDERWOOD. No; rather it has decreased on account of the packer jar making inroads into that particular division, such as the peanut butter jar that is reused, and so on, and so forth.

Senator KING. There has been a diminishing market, then?

Mr. UNDERWOOD. Yes.

Senator KING. Has there been overproduction?

Mr. UNDERWOOD. Well, I can't say that there has been overproduction, because those who manufacture fruit jars are very well versed in the consumption, and I believe that they just simply wouldn't over-produce.

Senator KING. Has there been any decrease in price?

Mr. UNDERWOOD. I am not familiar with that, Senator, because I haven't followed that particular phase of the situation since we passed out of the picture.

Mr. Cox. You spoke a moment ago of the inroads the packers' ware was making in the fruit-jar field. Do you have any opinion as to whether those inroads are caused at least in part by the fact that packers' ware sells at a lower price?

Mr. UNDERWOOD. Well, I can't say that that is the sole reason. Glass is being used by the consuming public in products not to such an extent as we have had heretofore. For instance, the housewife today will take a peanut-butter jar with a finish, that G finish, and they will use the peanut butter from the jar and save the jar by going to the store and purchasing a cap that will accommodate it.

It seems that during the past few years that practice has become more popular.

Senator KING. That reduces consumption.

Mr. UNDERWOOD. Yes; insofar as the domestic jar.

The CHAIRMAN. Do all of the companies manufacture jars in such fashion as to accommodate a standard cap?

Mr. UNDERWOOD. Yes; the quart jar, the quart packers' jar is pretty commonly manufactured with what we know as a G finish which will accommodate the zinc cap that Mr. Ball referred to this morning.

Mr. Cox. Could you manufacture and sell carbonated-beverage bottles?

Mr. UNDERWOOD. Yes, sir; we could do that very nicely.

Mr. Cox. Could you do the same with milk bottles?

Mr. UNDERWOOD. Yes. The field is greater for profit I think volume-wise in the carbonated beverage bottle than it would be in the milk bottle.

Mr. Cox. Did you ever apply to Hartford-Empire for permission to make carbonated beverage bottles?

Mr. UNDERWOOD. Yes, sir.

Mr. Cox. Were you granted that privilege?

Mr. UNDERWOOD. No, sir.

Mr. Cox. Did they tell you why you couldn't do it?

Mr. UNDERWOOD. I can't say that they ever gave us any detailed reply on that. They simply refused it.

Mr. ARNOLD. Did they say anything about stabilizing production of the industry or anything of that sort?

Mr. UNDERWOOD. In their reply to me on the subject I don't recall that they put it that way.

Senator KING. Are there licensees for the manufacture of those bottles?

Mr. UNDERWOOD. Yes.

Senator KING. How many licensees?

Mr. UNDERWOOD. I imagine that there are possibly 10 or 12 manufacturers who are licensed to make carbonated-beverage bottles.

Senator KING. Are there any other companies that hold patents under which carbonated-beverage bottles might be made other than the patentee?

Mr. UNDERWOOD. No; not in our country. I believe that if you were to—

Senator KING (interposing). I am speaking of the United States.

Mr. UNDERWOOD. That is right.

Mr. Cox. Mr. Underwood, are you reasonably familiar with the provisions of your license agreements with the Hartford-Empire?

Mr. UNDERWOOD. Fairly well.

Mr. Cox. We have introduced here in evidence marked "Exhibit No. 118"¹ a license agreement between Hartford-Empire and four other glass companies. Section 8 of that agreement reads as follows [reading from "Exhibit No. 118"]:

No changes and no additions other than reasonable and necessary repairs and other than necessary or proper safety appliances shall be made in or to said leased machinery except by consent of both parties to this license and lease, or except as provided in section hereof for the event of injunction, and except as provided in this section for improvements, and all changes and additions when made shall become the property of the licensor.

I want to call your attention particularly to this sentence:

Complete title to all patent rights at any time possessed during the term of this license and lease by the licensee, covering such changes and additions, shall be transferred to the licensor.

As I understand that provision, Mr. Underwood, it means that if you make any improvement on the machines you have in your establishment during the term of this license and obtain a patent on that improvement, that patent must be transferred to Hartford-Empire.

¹ Entered supra, p. 405.

Mr. UNDERWOOD. That is right, as I understand it.

Mr. COX. Does that agreement serve as an incentive to you to do experimental and development work in an attempt to improve your machines?

Mr. UNDERWOOD. Well, to be frank about the matter, I would say no, not to an independent organization that is desirous of developing their own technique. They are loath to do so in view of the fact that it will extend to Hartford and as a result of that reach all of their other licensees who are your competitors.

Senator KING. Do you have a research organization?

Mr. UNDERWOOD. Small.

Mr. COX. Is that provision in your contract?

Mr. UNDERWOOD. I believe that it is.

Mr. COX. We have heard some testimony here about services, engineering and otherwise, which Hartford-Empire performs for its licensees. Do they perform those services for you and your company?

Mr. UNDERWOOD. I believe that under their contract they agree to furnish that service, and I believe they do to a greater or lesser extent to all their licensees. In our particular situation it is lesser.

Mr. COX. You don't find that you need that service.

Mr. UNDERWOOD. Not in all cases. We don't require their services or, in other words, we don't depend upon the Hartford-Empire people to operate our plants.

Senator KING. Have they refused when you have asked?

Mr. UNDERWOOD. Not at all. They are always willing, on the other hand, to assist us.

Mr. COX. You don't find it necessary to ask them very often.

Mr. UNDERWOOD. That is right.

Mr. COX. Mr. Underwood, do you recall what you had to pay for the Hartford machinery which you now have? I am not speaking about royalties you paid for producing ware, I am speaking about the license fees. Take the feeder, for example, and tell me what you paid for the Hartford feeder in the way of a license fee.

Mr. UNDERWOOD. If my memory serves me correctly in that connection I believe that we paid for a license fee approximately \$2,000 and for the physical parts about \$2,300 to \$2,500, after which we pay the regular rate of royalty.

Mr. COX. To get that license you pay \$4,500.

Mr. UNDERWOOD. That is right.

Mr. COX. Then you don't own it.

Mr. UNDERWOOD. The title vests in the Hartford Co.

The CHAIRMAN. What do these parts consist of?

Mr. UNDERWOOD. Cams to operate the plunger, and different mechanisms that are on the feeder, such as maters and shears.

The CHAIRMAN. That is ordinary repair parts.

Mr. UNDERWOOD. Yes; that will be necessary in the construction.

The CHAIRMAN. How about improvements?

Mr. UNDERWOOD. Any improvements that Hartford would bring out they pass along to us with their usual charge.

The CHAIRMAN. So that if Hartford research or engineering bureau should develop improvements upon the machines which you have, you would be entitled to those.

Mr. UNDERWOOD. They extend to us under our license.

The CHAIRMAN. Have you received those in the past?

Mr. UNDERWOOD. I believe that any that they have developed they have passed along to us.

The CHAIRMAN. I noticed that in the earlier part of your testimony you referred to having taken a license on 25 units.

Mr. UNDERWOOD. Yes, sir.

The CHAIRMAN. Is that a limitation?

Mr. UNDERWOOD. Yes.

The CHAIRMAN. Could you use 30 units if you wanted them?

Mr. UNDERWOOD. Well, sometime, we thought we could use 60.

The CHAIRMAN. I don't mean that. I mean are you under your agreement permitted to use 30 or 60 units if you can?

Mr. UNDERWOOD. No.

The CHAIRMAN. Then you are limited to 25 units.

Mr. UNDERWOOD. We were at that time. That has since been increased.

The CHAIRMAN. What is it now?

Mr. UNDERWOOD. To a total of all our associated companies of 39 units.

The CHAIRMAN. So that no matter what business you and your associated companies may develop, you may under this agreement use only this specific number of machines?

Mr. UNDERWOOD. That is right, sir.

The CHAIRMAN. And under this agreement you are also limited with respect to the output?

Mr. UNDERWOOD. That is right, sir.

Mr. COX. Mr. Underwood, did you know, prior to these hearings, that the royalty you were paying Hartford-Empire was being divided between them for a period with Hazel-Atlas and Owens-Illinois?

Mr. UNDERWOOD. I certainly did not.

Mr. COX. Do you think that situation places your company at a competitive disadvantage against a company like Hazel-Atlas which is receiving in turn a part of the royalty?

Mr. UNDERWOOD. In my opinion, at a great disadvantage.

Senator KING. May I ask about these machines? I saw a picture of these machines. They are rather complicated, are they not, with a great many parts?

Mr. UNDERWOOD. Yes, sir; undoubtedly.

Senator KING. What would be the cost to build a machine with dies and so on, if you didn't have the dies and forms?

Mr. UNDERWOOD. That is for a Hartford feeder?

Senator KING. Yes; for the machine which you use in making these milk bottles and these containers?

Mr. UNDERWOOD. Well, in the manufacturing of the container we have two units, one known as the feeder device, and under that the forming machine. Which one do you refer to, the feeding device or the forming machine? Or the complete unit?

Senator KING. The complete unit.

Mr. UNDERWOOD. Oh, I would say that for us to jig our machine shop up, drawings, patterns, and all the necessary work to make the first machine would be considerable, possibly three times the cost of the finished product as we can purchase it now.

Senator KING. Could you build one for \$500,000, making your dies and jigs—supposing you started from scratch, to use an expression, buy the material and steel and whatever products are necessary?

Mr. UNDERWOOD. On the equipment we use today, we feel that we could take a bottle-forming machine, together with a feeder, and build the unit ourselves, if we were permitted to use—if we didn't meet patent interference—for possibly \$40,000 to \$50,000. That is our first unit. We have calculated that. However, we can purchase that same unit today from the Lynch Corporation and the Hartford-Empire Co. for half that amount.

Senator KING. That is all.

Mr. Cox. Have you ever made any computation as to what it would cost you thereafter to produce additional—

Mr. UNDERWOOD (interposing). Well, I believe we could do just as good a job as they do after we are equipped and with the personnel and jigs to do it.

Mr. ARNOLD. Do you think there is any great superiority in brains in the organization in any one section of the glass industry which requires them to have any peculiar advantages in order for them to use those brains?

Mr. UNDERWOOD. Will you repeat that question?

Mr. ARNOLD. I will preface the question with an explanation. It has been suggested at various times in the hearing that in certain parts of the glass industry, organization and skills and techniques have been affected to such an extent that it might be a pretty good thing for the industry, since those people know the industry so well, to centralize power in their hands. That inference might be drawn. Do you feel that to be an effect?

Mr. UNDERWOOD. Not to such an extent as was brought out here yesterday.

Senator KING. That is all.

The CHAIRMAN. If there are no other questions, Mr. Underwood may be excused.

Mr. Cox. I'd like to put on one more witness, if I may, after Mr. Underwood.

Senator KING. Will that be long?

Mr. Cox. I think we can be through in 15 minutes.

The CHAIRMAN. Suppose we put him on.

(Mr. Underwood was excused from the stand.)

Mr. Cox. With the chairman's permission, I am going to ask Mr. Hamilton to examine the next witness.

The CHAIRMAN. That is agreeable. Will you please call the next witness?

Mr. HAMILTON. Mr. Geer and Mr. Jaspert.

The CHAIRMAN. Do you and each of you solemnly swear that the testimony you are about to give in these proceedings shall be the truth, the whole truth, and nothing but the truth?

Mr. GEER. I do.

Mr. JASPERT. I do.

TESTIMONY OF PAUL L. GEER, TREASURER, AMSLER-MORTON CO.,
PITTSBURGH, PA.; AND TESTIMONY OF WILLIAM B. JASPERT,
PATENT ATTORNEY, PITTSBURGH, PA.

Mr. HAMILTON. Now, Mr. Geer, will you please state your name and occupation to the reporter?

Mr. GEER. My name is Paul L. Geer. I am treasurer of the Amsler-Morton Co., located in Pittsburgh, Pa.

Senator KING. Which company is that?

Mr. HAMILTON. Amsler-Morton Co. Mr. Jaspert, will you please give the reporter your name and occupation?

Mr. JASPERT. I am patent attorney in the city of Pittsburgh, and I am representing, or have represented, the Amsler-Morton Co. in litigation and advice on glass machine making equipment.

Mr. HAMILTON. Now, Mr. Geer, will you please describe briefly the business in which the Amsler-Morton Co. is engaged?

Mr. GEER. We are in the engineering and contracting business for the purpose of supplying melting and annealing equipment for the glass industry.

Mr. HAMILTON. Is it true to say that the Hartford-Empire Co. is also engaged in that business?

Mr. GEER. Yes; they are engaged in the same business, but, of course, we are one of the small businessmen compared to that concern.

Mr. HAMILTON. You say that you are engaged in the manufacture of glass machinery. Do you specialize in any particular type of glass machinery manufacturing?

THE CONTROL OF THE LEHR

Mr. GEER. We specialize in the glass-annealing equipment.

Mr. HAMILTON. Will you please describe briefly what glass-annealing is?

Mr. GEER. Well, the complete operation is comprised of a glass-melting furnace, a feeder, a forming machine, and a lehr.

Senator KING. What is a lehr?

Mr. GEER. It is a device for annealing the glassware after it is formed.

Mr. HAMILTON. Would you say that it is correct to describe a lehr as being a kind of oven into which the hot glass is put as it comes off the forming machine and in which the temperature of the glass is lowered until it finally comes out of the end definitely set and formed?

Mr. GEER. That is correct.

Mr. HAMILTON. Do you have any patents on lehrs?

Mr. GEER. We have a number of patents on lehrs, applying to our particular method of producing the result.

Mr. HAMILTON. Mr. Geer, I should like to ask you when you first began, that is when your company first began the manufacture of lehrs.

Mr. GEER. We first began the manufacture of lehrs in 1915.

Mr. HAMILTON. Have you been engaged in that business continuously since?

Mr. GEER. We have been engaged in that business continuously and up to about 1934 we built approximately 400 lehrs for the industry. Since that time, of course—

Mr. HAMILTON (interposing). I will get to that.

Senator KING. Could those lehrs be used independently of the mechanism necessary to reduce the sand and other ingredients to glass?

Mr. GEER. It is a composite part of the whole operation.

Mr. HAMILTON. But it could be used with any kind of feeder or any kind of tank or any kind of former.

Mr. GEER. Or even for annealing hand ware.

Mr. HAMILTON. Now you say you have patents upon lehrs. Have you ever inaugurated an infringement suit upon your patents?

Mr. GEER. Never.

Mr. HAMILTON. Has anyone ever charged you with infringing their patents by your making your lehr?

Mr. GEER. We have been charged with infringing a number of times by the Hartford-Empire Co.

Mr. HAMILTON. When were you first charged?

Mr. GEER. As soon as we developed the unit lehr between '26 and '27, and especially when we placed them on the market in quantities in the early part of '28. They charged us with infringement and finally invited us to go to Hartford.

Mr. HAMILTON. Did you accept that invitation to go to Hartford?

Mr. GEER. Yes; we accepted it because there seemed to be some question in their minds as to the matter of infringement and they wanted to discuss the lehr in general, and some possible plan for getting together.

Mr. HAMILTON. With whom did you discuss the situation when you went to Hartford, at their invitation?

Mr. GEER. We discussed the matter with Mr. Smith and possibly 8 or 10 other engineers.

Mr. HAMILTON. What proposals were put forward either by you or Mr. Smith at that time?

Mr. GEER. The first thing they asked was whether we had brought the drawings along of our equipment, and when we told them we didn't bring them, they offered different suggestions for getting together. At that time the price of our lehr was \$9,500 for the 4 by 75 foot lehr, which is the lehr used mostly in the hollow-ware industry, and they suggested that we raise that price to \$13,500, for which they would grant us a cross-license and we were to pay them the difference, or \$4,000.

Mr. HAMILTON. Can you tell us what the comparable Hartford-Empire lehr was selling for at the time Mr. Smith made this proposal to you?

Mr. GEER. From the information we have been able to collect, they charged a price of \$6,500 for the license. The purchaser was required to pay the cost of the erection and in addition they were obliged to pay a license fee of \$100 a month at that time.

Mr. HAMILTON. If you had accepted Mr. Smith's proposal, would that have placed you at a definite competitive disadvantage?

Mr. GEER. Definitely.

Mr. ARNOLD. In other words, you were competing with them and also paying part of your profits back to them.

Mr. GEER. Exactly.

Mr. HAMILTON. Well, now, you rejected the proposal, I take it.

Mr. GEER. Yes, sir.

Mr. HAMILTON. Then did Hartford-Empire take any further steps in regard to their claims that your lehr was infringing their patent?

Mr. GEER. Well, after we rejected the proposal, we returned to Pittsburgh, attempting to go on as we had in the past, charging a fixed price for the lehr and selling it outright, with no royalties, and they, of course, got busy immediately to make the sale difficult by threatening suit to the customers and other means of coercion which I could explain.

Mr. HAMILTON. What I am interested in more particularly, Mr. Geer, is any particular negotiations you had with Hartford-Empire or anyone else regarding your lehr and Hartford-Empire's claim that it infringed their patents.

Mr. GEER. After we refused the agreement, they sent two members of the British Hartford-Fairmont Co. to see us, at which time they offered us \$10,000 for the British rights, agreeing to give us \$2,000 cash for the drawings, which we rejected, and Mr. Amsler, a former member of our company who was then connected with the Hartford Co., made numerous visits to our office for the purpose of obtaining information as to the construction and—

Mr. HAMILTON (interposing). I take it you didn't give him any information.

Mr. GEER. They finally submitted us a questionnaire and on advice of counsel we signed—

Mr. HAMILTON (interposing). That was relating to your lehr?

Mr. GEER. Yes. We answered about 30 or 40 questions.

Mr. HAMILTON. Did anyone offer to purchase your lehr business about this time or later?

Mr. GEER. Well, that wasn't until later.

Mr. HAMILTON. When was that?

Mr. GEER. We were approached by one Mr. Collin, of the Collin-Norton Co., in Toledo, early in 1934. Mr. Collin made an appointment and came to see us the next day, making an offer of \$200,000 for our glass business.

Mr. HAMILTON. That was just for your glass machinery manufacturing business?

Mr. GEER. That is right, and the patents.

Mr. HAMILTON. Did you accept that offer?

Mr. GEER. No; we didn't. We thought it was too low, and he raised the price to \$260,000, and, in fact, he approached me privately because of my having a controlling interest in the company; he approached me on the basis of selling out for \$200,000.

Mr. HAMILTON. That is your controlling stock interest.

Mr. GEER. Yes.

Mr. HAMILTON. Did you accept either his proposal to pay \$260,000 altogether, or \$200,000 for your controlling interest in the stock?

Mr. GEER. No; we didn't.

Mr. HAMILTON. Did he approach you again with any other proposition.

Mr. GEER. Yes; the first visit was in January 1934, and—

Mr. HAMILTON (interposing). Now you are referring to the original visit when he offered you \$200,000?

Mr. GEER. Yes.

Mr. HAMILTON. That was January 1934?

Mr. GEER. Yes; and in February he called up and made another appointment, and this time he brought with him Mr. Hazelton, vice president of the Owens-Illinois Glass Co., and Mr. Frazier, president of the Simplex Engineering Co., a competitor and a licensee of the Hartford Co.

Mr. HAMILTON. That is a licensee of the Hartford Co. to make lehrs.

Mr. GEER. That is right. This time he told us that his company, the Collin-Norton Co., of Toledo, were the people that combined the Owens Bottle Co. and the Illinois Glass Co. together, and that he was then a director in that company, and he also combined the Ed. Miller Machine Co. in Columbus, the O'Neill Machine Co. in Toledo, and the Lynch Machinery Corporation of Anderson, Ind., to operate and sell equipment under the Hartford license.

Mr. HAMILTON. What was his proposal to you at that time?

Mr. GEER. He proposed to combine the Simplex Engineering Co. and the Amsler-Morton Co. He suggested that each of us be permitted to remove the cash from the corporation, that we would each receive one-third interest in the new corporation.

Mr. HAMILTON. By each? Whom do you mean?

Mr. GEER. Mr. Frazier and ourselves would each receive a third interest in the new corporation, and another party, whom he did not mention, would receive the other third.

Mr. HAMILTON. Did he make any reference to Hartford-Empire's claim that your lehr infringed its lehr patents?

Mr. GEER. Oh, that came up in the course of the conversation, but he went on to say that the person or interest obtaining the third interest in the combined corporations would put up half a million dollars to finance the combination; that he would guarantee us all of the construction work for the Owens-Illinois Glass Co. and others that he did not mention; and he would also obtain a cross-license from the Hartford Co. to build lehrs; and, in fact, we would be permitted to build all of their lehrs.

Mr. HAMILTON. Did you accept that proposal?

Mr. GEER. No; we told him if he would give us 51 percent of the proposition, we would consider it, but not otherwise. We, of course, discussed the thing for probably 2 hours after that. We didn't change our opinion, and as Mr. Hazelton got up to leave, he said, "Boys, we have made a good offer to you now. You can make a lot of money out of this. I will give you 1 month to consider it. If you don't go in with us on this thing," he said, "we will enter suit against you and we will continue to sue you until you are out of business." And he made this statement, that "It is our plan that nobody in the glass industry should own one piece of glass-making equipment."

Mr. HAMILTON. At the end of 1 month after you had considered this proposition, did you accept Mr. Hazelton's proposal?

Mr. GEER. No; we didn't do anything about it, but the Hartford-Empire Co. entered suit against the Swindell Co. in Baltimore, one of our customers.

Mr. HAMILTON. Did you defend that suit?

Mr. GEER. We were obligated to defend it because we had written into the contract that we would defend and hold them harmless against any litigation.

Mr. ARNOLD. Why do you think they sued your customer rather than yourselves?

Mr. GEER. That is very simple. If they had sued us, we would have entered a counter-suit against them because we owned the prior patent that we still believe would have them tied up, and, suing Swindell as they did, we were obliged to enter the suit with the situation as we found it in that Swindell had previously brought three lehrs from the Hartford Co. in which they agreed, unknown to us, to not contest the validity of the Hartford patents. Entering that suit as we did, we had to defend it on the basis of noninfringement and were unable to have a fair fight.

Mr. ARNOLD. In other words, because of that license to Swindell, you were unable in that suit by any means whatever to bring your counter-claims for infringement.

Mr. GEER. That is correct.

Mr. ARNOLD. If it hadn't been for that license, you might have done it.

Mr. GEER. We would have. We may yet.

Mr. HAMILTON. What was the result of that suit in the district court? Who won it? That is what I want to know.

Mr. GEER. We won the suit in the lower court, principally because we proved that the Hartford patent was a reissue taken out 2½ years after the original patent.

Mr. HAMILTON. Mr. Geer, then what happened when the case went up on appeal?

Mr. GEER. We received the favorable decision in the lower court, and when it went up on appeal the decision was reversed, and that is the way the decision stands today.

Mr. HAMILTON. You told us awhile ago, I believe, that your company had made in all 400 lehrs.

Mr. GEER. That is correct.

Mr. HAMILTON. And that was over a period of approximately 20 years?

Mr. GEER. A little over 20 years.

Mr. HAMILTON. Do you recall how many lehrs you made and sold in 1934?

Mr. GEER. It dropped precipitously at that time.

Mr. HAMILTON. The Swindell suit was filed in 1934?

Mr. GEER. In 1934. Now I am referring to the bottle industry. We had been selling approximately 20 lehrs per year up to that time, and in 1934 we sold 5, and in 1935 I think 4, and it has gradually gotten down to 1 at the present time.

Mr. HAMILTON. What do you mean by the present time—1938?

Mr. GEER. 1938.

Mr. HAMILTON. You have only sold one this year?

Mr. GEER. Only one this year.

Mr. HAMILTON. How many did you sell in 1937?

Mr. GEER. I don't believe we sold any in 1937.

Mr. HAMILTON. Can you tell me how much the Swindell litigation cost your company?

Mr. GEER. Well, it was tremendous for a small concern.

Mr. HAMILTON. How much was it?

Mr. GEER. It amounted to close to \$50,000, and that doesn't take into consideration the expense of our organization.

Mr. HAMILTON. Is that litigation terminated, or is the case still pending?

Mr. GEER. No; the case is still pending.

Mr. HAMILTON. Is the reason that your sales dropped the fact that your customers are apt to be sued if they buy?

Mr. GEER. That is true.

Mr. HAMILTON. Mr. Geer, can you tell me who Mr. Hazelton was, and Mr. Collin? What did you say their full names were?

Mr. GEER. Everybody knows him as Ben Hazelton, but I think his full name is Benjamin.

Mr. HAMILTON. Can you give me the full name of Mr. Collin?

Mr. GEER. Harry Collin, I believe.

Mr. HAMILTON. You told us awhile ago that you were offered \$260,000 in the first part of 1934 for your glass-manufacturing machine business.

Mr. GEER. That is correct.

Mr. HAMILTON. You say the litigation has cost you \$50,000 already?

Mr. GEER. That is correct.

Mr. HAMILTON. I would like to ask you this: You also told us, I believe, that you have sold only one lehr so far this year.

Mr. GEER. That is correct.

Mr. HAMILTON. That you sold no lehrs last year. What would you say the value of the glass-manufacturing machinery business is now? That is, your business.

Mr. GEER. I will give you a comparison. In '28 we were doing \$800,000 worth of business and last year we had \$18,000 worth of business in the glass industry—quite a drop.

Mr. HAMILTON. You are still continuing the fight?

Mr. GEER. We are going to continue as long as we can. We believe we are right and we are going to stick to it.

Senator KING. Was Mr. Hazelton identified when he came to see you?

Mr. GEER. He was vice-president of the Owens-Illinois Glass Co.

Senator KING. Is he still?

Mr. GEER. I can't answer that.

Mr. HAMILTON. Did the Hartford-Empire Co. circularize the glass machinery purchasing trade after they filed their suit against Swindell?

Mr. GEER. They circularized them sometime after that. I can't say exactly when, but they had previously circularized the trade, advising that we were infringing their patents long before that.

Mr. HAMILTON. Thank you very much.

Mr. GOODRICH. At this point, Mr. Chairman, in connection with this last witness, I offer to you and ask that it be taken into the record and printed, a copy of the decision of the fourth circuit court of appeals in the case of Hartford-Empire Co. versus Swindell Bros., Inc., and the Amsler-Morton Co., intervenor, which is found in 39 U. S. Patent Quarterly, 87, and the decision on rehearing and the argument which is found in 96 Fed. (2) 227.

The CHAIRMAN. Mr. Goodrich, we have been trying to keep the record down as much as possible. You have observed that I have excluded many of the documents presented by the Department of Justice. In this case if you will be good enough to file the citations of

all of the cases I think they will be available to all the members of the committee. We each have libraries and the Supreme Court Library is available and the Library of the Senate, and it probably would be unnecessary to put it in the record.

Mr. GOODRICH. I am sure that is so, Your Honor, but this record goes out to a great many people who are not members of the committee, and if this patent case is to be retried before this committee, certainly I would like to have the decision there.

The CHAIRMAN. I think the patent case is not being retried.

Mr. ARNOLD. The statement is in the record that the lower court was reversed, and that is all you really want, isn't it?

Mr. GOODRICH. Coupled with the statement, Mr. Arnold, that there was a rehearing before the circuit court and the decision again upheld.

Mr. ARNOLD. I think we can show that and you can give the citation in the record now.

Mr. GOODRICH. 96 Federal Reporter (2d) 227, and the first report was found in 39 U. S. Patent Quarterly 87.

Senator KING. Have you extra copies of your brief?

Mr. GOODRICH. These are not the brief, Senator; these are the decisions. I will be glad to leave these. We have extra copies.

Mr. COX. I should like to make a vigorous objection to any characterization of this testimony as a retrial of the patent case.

The CHAIRMAN. It was stated by the chair as not a retrial.

Mr. GOODRICH. I didn't mean to start a controversy on that.

The CHAIRMAN. I understand that, Mr. Goodrich.

Are there any other questions?

Mr. HAMILTON. I have none.

The CHAIRMAN. Do any members of the committee desire to ask Mr. Geer any questions?

Mr. GEER. I think I ought to make a further statement here before leaving, and that is during the trial they brought out the importance of their design of lehr and at the same time they were getting ready to offer to the trade a cheaper and more inexpensive lehr, amounting to \$2,500, and \$2 per day royalty.

The CHAIRMAN. The committee will stand in recess until tomorrow morning at 10 o'clock.

(Whereupon, at 4:20 p. m., an adjournment was taken until Friday, December 16, 1938, at 10 a. m.)

INVESTIGATION OF CONCENTRATION OF ECONOMIC POWER

FRIDAY, DECEMBER 16, 1938

UNITED STATES SENATE,
TEMPORARY NATIONAL ECONOMIC COMMITTEE,
Washington, D. C.

The committee met at 10:15 a. m., pursuant to adjournment on Thursday, December 15, 1938, in the old caucus room, Senate Office Building, Senator Joseph C. O'Mahoney presiding.

Present: Senators O'Mahoney (chairman), and King; Messrs. Henderson, Arnold, Berge, Peoples, and Coe (U. S. Commissioner of Patents); Representative Summers.

Present also: Department of Justice staff for Temporary National Economic Committee study—counsel, H. B. Cox (Special Assistant to the Attorney General); Joseph Borkin, Ernest Meyers, Charles L. Terrel, Benedict Cottone, David Clarke, George Dession, Fowler Hamilton, H. C. Engelbrecht, Victor H. Kramer, J. M. Henderson, Monroe Karasik, Irving Glickfeld, Hyman Ritchin, Norman Bursler, and Seymour Lewis; also chief counsel for Federal Trade Commission Temporary National Economic Committee study, George W. Williams.

The CHAIRMAN. The committee will please come to order. We have convened this morning a little bit earlier than our usual hour, and I regret to say, Senator King, Mr. Peoples, and other members of the committee, the attendance is a little bit light this morning. Three of the members are suffering from colds and asked me to send word to proceed without waiting for them.

Have you your witness?

Mr. Cox. Mr. Safford. Mr. Pease. Mr. Pease is another official of Hartford. Mr. Pease has not been sworn.

The CHAIRMAN. Mr. Pease, do you solemnly swear that the testimony you are about to give in this proceeding shall be the truth, the whole truth, and nothing but the truth, so help you God?

Mr. PEASE. I do, sir.

The CHAIRMAN. You may be seated.

TESTIMONY OF A. T. SAFFORD, SECRETARY AND COUNSEL, HARTFORD-EMPIRE CO., HARTFORD, CONN.—Resumed; AND A. M. PEASE, ASSISTANT TREASURER, HARTFORD-EMPIRE CO., HARTFORD, CONN.

Mr. Cox. Mr. Safford, I am going to hand you a document and ask you if it is a document that you are prepared to accept as a true and correct photostatic copy of an agreement between the Hartford-Empire Co. and the Lynch Corporation, dated August 23, 1933.

Mr. SAFFORD. The agreement is not complete.

Mr. Cox. You are referring to a later amendment of the agreement? ¹

¹ The amended agreement, dated November 12, 1938, was subsequently entered as "Exhibit No. 152." See *infra*, p. 606.

Mr. SAFFORD. A later amendment; yes.

Mr. COX. But this, prior to the amendment which was made of a date this year, and I will take that up in a moment, is a true and correct copy of the agreement?

Mr. SAFFORD. Yes; as executed.

Mr. COX. I should like, before I offer this document for the record, to read one provision which is found in section 2 of the agreement, which reads as follows [reading from "Exhibit No. 150"]:

Lynch grants to Hartford a nonexclusive license to make for itself or have made for it, to sell, and lease forming machines of designs made or acquired by Hartford and embodying Lynch forming machine inventions, and to license others to use, but not to make and/or sell, any forming machines embodying Lynch licensed forming machine inventions.

Provided, That neither the grant herein to Hartford of the right to license others to use said inventions, nor any sublicense granted by Hartford thereunder, shall be extended by implication under any circumstances to include a right in Hartford's sublicensee to make any forming machine embodying Lynch licensed forming machine inventions.

The license granted in this section 2 shall be nonassignable except to the successor of the entire business of Hartford.

I should like to have this contract marked as an exhibit though it need not be printed in full in the record.

The CHAIRMAN. The document may be marked as an exhibit.

(The agreement referred to was marked "Exhibit No. 150" and is on file with the committee.)

Mr. COX. Mr. Safford, will you tell us briefly what the Lynch Corporation is?

Mr. SAFFORD. The Lynch Corporation is engaged in the manufacture of forming machines and at the present time it is the largest manufacturer of forming machines, I believe, in the world.

Mr. COX. Was it the largest in 1933 when the contract was made?

Mr. SAFFORD. So far as I know; yes.

Mr. COX. Now, Mr. Safford, will you tell us who Mr. Werbe is?

Mr. SAFFORD. Mr. Werbe is president of the Lynch Corporation.

Mr. COX. I am now going to read to you a part of a letter which you addressed to Mr. Werbe under the date of September 20, 1933, and afterwards I will hand you this document and ask you if it is the letter which in fact you did send to Mr. Werbe.

The CHAIRMAN. Mr. Cox, may I inquire? You stated that the contract which you just had identified was amended.

Mr. COX. That is correct.

The CHAIRMAN. I was wondering if that amendment in any way modified the contract.

Mr. COX. It does, and I am coming to that. The reason I am taking the letter up first is because the letter antedates the amendment Mr. Safford spoke of [reading from "Exhibit No. 151"]:

This is in answer to your letter of September 13 regarding Universal and the procedure to be followed generally in granting forming machine licenses to those persons who wish to obtain forming machines from you. If Universal advised you that they had a forming machine license they are evidently laboring under some misconception as to the extent of their present license. This license is merely to cover six feeders in the production of principally milk bottles. We shall, however, send them a forming machine license some time this week, along with our form letter and such other information in regard to their particular situation as seems necessary.

I am going to omit the next two paragraphs, which are not germane [reading further from "Exhibit No. 151"]:

As our general procedure for dealing with each person who wishes one of your forming machines, we suggest the following: We shall send you a list of our feeder licenses and keep it revised for you. When you get an order for a forming machine you will advise us. If it is free from the feeder licensee we shall then forward to the licensee our standard forming machine license agreement adapted to the licensee's particular field of ware. This the licensee is to sign and return to us. If he is not a licensee, then you will decline to furnish the machine in such language as appears proper to you under the circumstances. If it is to a feeder licensee to whom we are sending a forming machine license, you will send your usual sales contract for execution. When we have advised you that our forming machine license is signed and you have a signed copy of your own contract, you can then make delivery of the machine.

Is this the letter which in fact you did send to Mr. Werbe?

Mr. SAFFORD. Yes. I recognize that letter, Mr. Cox, and that letter may be capable of misconstruction. Under the Lynch forming-machine agreement, as I recollect it, there was a covenant on our part to extend the licenses of all our feeder licensees automatically, so that they without further payment would be entitled to use Lynch forming machines with a license from us. That appears from the agreement as written. Subsequently some misconception arose as to the meaning of the agreement. As a matter of fact, the Department of Justice itself raised the question of the construction of that contract and subsequently we wrote another letter clearing up that matter.

I might explain, Senator, that in 1935 some question came up by which the Department of Justice became interested in us. I have forgotten the exact details. At that time we voluntarily went to the Department, offered to let them have access to all our contracts, and we stated at that time we welcomed any suggestions which they might have with reference to our contracts. They sent an investigator to Hartford who did make such an investigation and raised various points which he felt made those contracts susceptible to misinterpretation. In those two or three instances, so far as I know, we modified the contracts accordingly, and after his visit we wrote again to the Department stating the original purpose of the visit of the investigator, and stating also that we welcomed any suggestions which they might make with reference to our contractual system.

Mr. ARNOLD. What year was this?

Mr. SAFFORD. I think that was 1935, Mr. Arnold. It was when Mr. Dickinson was Assistant Attorney General.

Mr. COX. Have you finished, Mr. Safford? I point out to the committee that the answer was not responsive to the question, but I am prepared to let it stand and let the contract speak for itself and let the letter speak for itself, too, which I should like to offer now.

The CHAIRMAN. The letter may be received.

(The letter referred to was marked "Exhibit No. 151" and is included in the appendix on p. 793.)

Mr. COX. So far as this particular letter is concerned and so far as section 2 is concerned, whenever the investigator of the Department may have visited you, you didn't modify that until November of this year, did you?

Mr. SAFFORD. I think your investigators took at least one letter from our files in which we wrote to the Lynch Corporation stating that there was a misconception of the meaning of that term, and we were stating what we felt was our meaning of the term, and also

stating the fact that the other parties to the contract were unwilling to modify it at that time.¹

Mr. COX. But you did modify the contract by a formal document in this year, did you not?

Mr. SAFFORD. We did.

Mr. COX. I hand you a document entitled "Amended agreement between Hartford-Empire Co. and Lynch Corporation," dated November 12, 1938, and I ask you if that is a copy of the modification of that contract.

Mr. SAFFORD. Yes; it is.

Mr. COX. Mr. Safford, was this contract in fact made on November 12, or is it merely dated November 12?

Mr. SAFFORD. I don't know, sir.

Mr. COX. You are not prepared to answer that question?

Mr. GOODRICH. We are trying to get the date.

Mr. SAFFORD. I think that was the date it was signed.

Mr. COX. You are quite sure about that?

Mr. SAFFORD. No; I am not. It can stand at that.

Mr. COX. Very well; I offer this.

The CHAIRMAN. Is this for the record?

Mr. COX. I prefer not to have that one printed unless the other is printed, but I would like to have both go in as exhibits.

The CHAIRMAN. It may be so received.

(The amended agreement was marked "Exhibit No. 152" and is on file with the committee.)

Senator KING. Mr. Cox, would it interfere with your program if I should ask him very briefly the difference between the first contract and the modification contract, not all the terms, but the point as to which you said there was a misconception? I am not clear as to just what that misconception was.

Mr. COX. I am content to have the witness do that, but before he does I should like to say this: I have no doubt that the Department will not agree with his explanation of either contract. Since we are attempting under some difficulty to finish today, we are not going to go into that matter with the witness, but I would not wish the committee to think that we accept any statement he may make on that matter without qualification, merely because I do not examine him on it. With that qualification, I have no objection to Mr. Safford's making a statement.

Senator KING. If he is to be permitted to make a statement, he ought to do so.

Mr. COX. All I want you to understand is that by my failure to ask the witness, I am not acquiescing.

Senator KING. I am not asking you to be bound by anything he states unless you want to be. Proceed.

Mr. SAFFORD. To be perfectly frank, Senator, I don't think the amending agreement does affect the question which Mr. Cox raised the first time. The misconception which might have arisen with reference to that contract, I think I am correct in stating, was cleared up by a letter in 1936, and it is not embodied in the amending agreement, and if Mr. Cox wants to produce the letter, I am willing to identify it.

¹ Subsequently entered in record as "Exhibit No. 152." See appendix, p. 801.

Mr. COX. I am not aware what the letter is, but I am perfectly willing to have it go in the record,¹ if you have a copy of it.

Mr. SAFFORD. Perhaps Mr. Kramer can find the letter.

Mr. COX. We will find the letter. I would rather not stop now. If you can give me a copy, I can put it in the record.

Mr. SAFFORD. We understand, then, it will go in the record?

Mr. COX. I beg your pardon.

Mr. SAFFORD. I say, we understand from you it will go in the record.

Mr. COX. Will the reporter read to Mr. Safford the remark I made two statements before the last?

The REPORTER. "I am not aware what the letter is, but I am perfectly willing to have it go in the record, if you have a copy of it."

Mr. COX. Is that quite clear, Mr. Safford?

Mr. SAFFORD. Yes; that is fine.

Mr. COX. I may add for the committee's benefit, though, that we propose to demonstrate by another witness later this morning how this provision actually worked.

Mr. Safford, I am going to hand you a mimeographed copy of document entitled "Hartford-Empire Co. Analysis of Financial Statements," and ask you if that is a document which you have seen before, and which you have agreed to be substantially accurate.

Mr. SAFFORD. Yes; that is correct.

Mr. COX. I should like to have this document marked.

The CHAIRMAN. How do you identify this document? What do you call it?

Mr. COX. I read from the title at the top, "Hartford-Empire Co. Analysis of Financial Statements."

The CHAIRMAN. You asked that it may be marked and printed in the record?

Mr. COX. Yes.

The CHAIRMAN. It may be so received.

(The document referred to was marked "Exhibit No. 153" and is included in the appendix on p. 794.)

Mr. COX. Mr. Safford, I am going to hand you another document entitled "Hartford-Empire Co.," again "Analysis of financial statements," a one-page document, and I ask you if you have seen that and are satisfied as to its accuracy.

Mr. SAFFORD. That is correct.

Senator KING. Mr. Cox, that first offer embraced all these pages, did it not?

Mr. COX. Yes. I should like to offer this one page. We don't have to mark that, Mr. Chairman, because it is included in the document which I have already offered.²

I call the committee's attention to the fact that the last page of the document which Mr. Safford identified contains two compilations with respect to the rate of return received by the Hartford-Empire Co. The fourth column from the left contains a percentage figure which is entitled "Return on total investment." The figure in the last column toward the right is a percentage figure entitled "Return on investment employed in operations."

¹ Subsequently entered as "Exhibit No. 162." See appendix, p. 801.

² See "Exhibit No. 153," appendix, p. 794 at p. 798.

The CHAIRMAN. By whom was this analysis prepared?

Mr. COX. This was prepared in the first instance by the Department of Justice, and it has been substantially accepted, so far as its arithmetical accuracy is concerned, by the Hartford-Empire Co., is that correct?

Mr. SAFFORD. Yes; we accept in principle the method used in determining these figures.

Mr. COX. I point out that the two rates of return are figured on a different base. The first one, "Return on total investment," is figured on the basis of the second column from the left which is entitled "Total capital and surplus." The last figure on the right, "Return on investment employed in operations," is figured on a base which is shown in the fifth column from the left, headed "Net capital employed in operations." There are several differences between the composition of the figure entitled, "Total capital and surplus" and the figure entitled, "Net capital employed in operations," but I think there will be no disagreement if I state that the most substantial difference, and the thing that accounts for the greatest difference in the two figures, is the fact that total capital and surplus includes the amount of certain marketable securities held by the Hartford-Empire Co. as of recent years, 1937, and amounts to upward of \$2,000,000, whereas the figure "Net capital employed in operations" does not include the amount of those marketable securities. That would be an accurate statement?

Mr. SAFFORD. That is correct.

Mr. COX. I also call the committee's attention to the fact that in making this analysis, the Department has not attempted as is done in utility rate proceedings to make any evaluation of the assets of this company. We have accepted the valuation which has been given to us.

The rate of return for the period from 1912 to 1937 figured on the basis of the net operating income or loss amounts to 9.99 percent. I point out for the committee what we regard as a significant fact that beginning in 1932, which was the date which the Hazel-Atlas Co. gave up the struggle and took a license and at the same time that the contract was made with the Lynch Corporation, put in evidence this morning, the next year 1933, in the same year 1933, the Ball Bros. took a license and there has been testimony in the record that after the Hazel-Atlas case a large number of small manufacturers took licenses, and beginning with that period of time the rate of return on the investment employed in operation rose from 16 percent in 1933 to 67.77 percent in 1937.

Representative SUMNERS. Mr. Cox, have you any explanation as to how it came about that in 1931—I believe I have the correct column—the net income was 4.25, and the next year 10.37?

Mr. COX. In 1932?

Representative SUMNERS. What happened between 1931 and 1932?

Mr. COX. We have had testimony here that Hazel-Atlas, which was the second largest manufacturer in the field, took a license in 1932 and a large number of other manufacturers also took a license.

Mr. OLFPHANT. Have you available figures on the trend of corporate profits generally from 1931 to 1932? ¹ Is that up or down?

¹ See *infra*, p. 610.

Senator KING. Do you mean with respect to this corporation?

Mr. OLIPHANT. No; corporations generally.

Mr. COX. I am afraid we have nothing of the sort.

Mr. OLIPHANT. The trend of corporate profits in general.

Mr. COX. I am afraid we have nothing of that sort available this morning.

I am about to abandon the subject of these financial statements, so perhaps if the committee have any questions they would like to ask they may do it now.

Senator KING. Following the inquiry of Congressman Sumners, and perhaps this is a duplication of his inquiry, may I inquire again, because I didn't understand your answer, how it is that in 1932, with a total capital and surplus of \$5,243,000 plus, the return on investment employed in operations was 10.37, whereas in 1937, with capital and surplus substantially the same, the return on investment employed in operation as reported by this document is 67.77 percent?

Mr. SAFFORD. I think the explanation, Senator, which Mr. Cox gave is substantially correct, with perhaps this one additional statement, that the amount of glassware produced in this country has been steadily increasing over the last 10 years, and particularly after the repeal of prohibition. It jumped to the extent of, I should say, some 16,000,000 gross at the present time, due to liquors and beers.

Senator KING. Would that make that increase, that difference between 10.37 and 67.77 percent, with substantially the same surplus?

Mr. COX. Mr. Safford, just for my own information, did the upswing in production because of the change in the prohibition law—

Mr. OLIPHANT (interposing). May I interrupt to suggest that the Senator's question has not been answered?

As I understand it, the percentages in the last column are percentages of the figures shown in the third column from the end, and that the apparent discrepancy to which the Senator points is accounted for by the decrease in the amount of net capital employed in operation.

The CHAIRMAN. I think possibly the Senator would like to have the witness answer the question.

Senator KING. My able confederate on my right has projected himself very properly into the witness box.

Mr. OLIPHANT. I wanted the Senator's question answered.

Senator KING. Do you agree with the answer to the statement just made by Mr. Oliphant?

Mr. SAFFORD. The total capital and surplus stayed the same, approximately, in the period of 1932-37. In other words, the company issued no additional stock and the surplus remained substantially the same, as I remember, but the net capital employed in operations in the period between 1931 and 1937 shows a decrease. I should say the difference was due to our investments. In other words, more of the surplus was placed in investments, so that in 1937, while the total capital and surplus remained \$5,400,000, the net capital employed in operations, upon which the percentage is based, was \$2,500,000.

Senator KING. May I inquire whether or not any part of that 67.77 return on investment employed in operations was distributed to any of the associates of the Hartford, to those companies that had taken licenses? Did they get any part of that 67 percent?

Mr. SAFFORD. No, sir; they did not. This is the net figure, sir.

Senator KING. That was received and enjoyed exclusively by Hartford?

Mr. SAFFORD. That's right, sir.

Senator KING. That is all.

The CHAIRMAN. The only division was with the other two corporations, was it not, the Owens-Illinois and the Hazel-Atlas?

Mr. SAFFORD. Yes; there was a division of the gross returns, and of course OWENS was out by that time.

The CHAIRMAN. The Senator was asking whether or not there was any division of profits with your licensees. There was no such division?

Mr. SAFFORD. None.

Senator KING. That is all, Mr. Cox.

Mr. Cox. In response to the question which Mr. Oliphant asked a moment ago, I might state that we have here a copy of the financial letter of National City Bank of New York for April 1938, which contains a computation showing the rate of return for the years between 1926 and 1935, for all active corporations in the United States, compiled from annual statistics of income received by the Treasury Department, and that shows that the average return for all active corporations for that period of time was 1.50 percent. That is the closest we have to the figure you asked for, and does not cover the entire period involved here.

Senator KING. Does that paper show the losses, the deficits of the more than two hundred and thirty or forty thousand corporations?

Mr. Cox. It does show certain losses; yes, Senator. It shows nothing about the trend from year to year.

Senator KING. Of the corporate period from 1931 to 1933?

Mr. Cox. Yes. It shows here that in 1931—well, beginning 1930, for example, where the rate of return was 0.86, it dropped to a deficit or red figure of minus 1.95. In 1932 it was minus 3.75; 1933 it was minus 1.68. The figure minus 3.75 I should have read for 1932. In 1934 it rose to 0.13; in 1935, 1.18 percent.

Mr. Cox. I think I should like to put on another witness at this point, and I think I shall probably want to have Mr. Pease and Mr. Safford back for a short time afterward, but there is one witness here it would be convenient if we could go through with now.

The CHAIRMAN. Very well.

Mr. Cox. Mr. Coleman.

The CHAIRMAN. Do you solemnly swear the testimony you are about to give during this proceeding shall be the truth and nothing but the truth, so help you God?

Mr. COLEMAN. I do.

The CHAIRMAN. You may be seated.

TESTIMONY OF S. A. COLEMAN, JR., PORT ISABEL, TEX.

Mr. Cox. Mr. Coleman, you were at one time connected with the Knappe-Coleman Glass Co., were you not?

Mr. COLEMAN. Yes, sir; I was president of the Knappe-Coleman Glass Co.

The CHAIRMAN. Will you spell that?

Mr. COLEMAN. K-n-a-p-e.

Mr. Cox. Where was that glass company located?

Mr. COLEMAN. At Santa Anna, Tex.

Mr. Cox. Will you tell us how you first got into the glass business, Mr. Coleman?

THE ELIMINATION OF A TEXAS INDEPENDENT

Mr. COLEMAN. My original start in the glass business was in 1927, after finishing Texas A. and M. College with an engineering degree. I went to work for the Three Rivers Glass Co. at Three Rivers, Tex. Was with that company until I believe perhaps in 1931 or 1932 when they went into receivership and Mr. Knape, it so happened, was an engineer for that company, too, and shortly after that time we became interested in this plant at Santa Anna, Tex., that was not in operation, and shortly after that, I believe it was in 1933, we acquired the assets of the company and put the plant into operation in 1934, in the early part of 1934.

Mr. Cox. What kind of equipment were you using in that plant, Mr. Coleman?

Mr. COLEMAN. We had—I will say first, the equipment that we had; we had two Lynch LA machines, one Miller milk bottle machine, and two Miller feeders. However, we did not attempt to operate the Lynch machines on packers' ware, or similar items, as I think it has been brought out here before the committee that there is very little or no profit for a small manufacturer in such type of ware. However, there was no plant in Texas making milk bottles, so we decided to make milk bottles.

Mr. Cox. You did make milk bottles, did you, Mr. Coleman?

Mr. COLEMAN. Yes, sir; that is true.

Mr. Cox. Before we go on with the company, will you tell us what the capitalization of your company was?

Mr. COLEMAN. We were capitalized at \$72,000.

Mr. Cox. And the stock was all held in Texas, I suppose?

Mr. COLEMAN. That is true; yes, sir.

Mr. Cox. Held locally. Very well, now you said a moment ago you began to make and sell milk bottles. I suppose your market was largely in Texas, is that correct?

Mr. COLEMAN. Primarily the Texas market; yes, sir.

Mr. Cox. Was there anyone else competing with you for that market?

Mr. COLEMAN. Very strenuously. I should say the Liberty Glass Co., of Sapulpa, Okla.

Mr. Cox. Can you tell us what the relationship was between the prices at which you sold your milk bottles and the prices at which the Liberty Glass Co. sold its milk bottles?

Mr. COLEMAN. Well, I might add this information at this time, that in my opinion the price of milk bottles in Texas had not up to that time been based so much on cost as on the fact that it was a very fertile territory and the only good milk-bottle territory, as far as profits are concerned, between St. Louis and the Pacific coast. The Liberty Glass Co. sales and other manufacturing sales in the St. Louis area were at a very low price, and the profit I believe is doubtful in many cases. However, in Texas, where you find milk bottles in the St. Louis area being delivered at, I would say offhand, around six and a half a gross, you would find in many instances the same type of ware being sold at \$10, and I don't believe that freight

rates on the distance was materially different; that is, the cost to lay the ware down, but the other milk bottle companies in the East, outside of instances like the Port of Houston, could not compete due to rail deliveries. That left the Liberty Glass Co. with the Texas territory, which I believe they would admit themselves was the most profitable sales territory that they had.

Mr. COX. Were their prices higher than the prices at which you sold?

Mr. COLEMAN. They were substantially higher; yes, sir.

Representative SUMNERS. These milk bottles were sold at one price in one territory. Was Texas the \$8 territory? I so understood but wasn't sure.

Mr. COX. The \$6 territory was what was called the St. Louis.

The CHAIRMAN. Sold by the same persons?

Mr. COLEMAN. Sold by the Liberty Glass Co., and I believe a factory of Owens-Illinois, were competing in those territories. I don't believe Obear-Nester was in the milk-bottle business.

Mr. OLIPHANT. Does that mean milk bottles were selling at about \$6 in one territory and the same bottles were selling at about \$8 in another?

Mr. COLEMAN. I will say that is a very conservative estimate. The average Texas price, if anything, was higher than that.

The CHAIRMAN. The point is that the same bottles from the same manufacturer were sold at different prices in different areas?

Mr. COLEMAN. That is true; yes, sir.

Mr. COX. Will you tell us again the date when you started to sell milk bottles in Texas?

Mr. COLEMAN. We started in the spring of 1934, we sold our first milk bottles in Texas.

Mr. COX. What happened after you opened your plant and began operations?

Mr. COLEMAN. Well, we naturally began to have visitors and correspondence. Our first visitors were from Ball Bros., but when they found out we weren't going to make fruit jars they wished us all manner of success. [Laughter.] And then about that time, some 3 months—2 to 3 months after starting operations—we received a letter from the Hartford-Empire Co. notifying us that we were infringing upon certain of their patents.

The CHAIRMAN. Did you get an invitation?

Mr. COLEMAN. I think we delayed that some 6 or 7 months, but we did receive one; yes, sir.

Mr. COX. Now, tell us, as rapidly as you can, what happened between the time you got this notice of infringement and 6 or 7 months later when you got your invitation from Hartford.

Mr. COLEMAN. Well, a curious situation had arisen in Texas. The Liberty Glass Co. had just shortly before we began operation, paid Three Rivers Glass Co. \$50,000 for their milk-bottle rights, even though they had no license to make milk bottles, but they had seen fit for a number of years to make milk bottles anyway. So this \$50,000 had just been spent, and here another company jumps up out of the brush somewhere making better milk bottles, in my estimation, than Three Rivers had made, and much better located from a sales standpoint. We were in the exact center of Texas.

The CHAIRMAN. You mean up out of the sagebrush.

Mr. COLEMAN. That's true. So Liberty felt very unkind toward us because we were taking over this territory that they had just paid \$50,000 for, and they promptly—I think they wasted very little time complaining to the Hartford-Empire Co. of the fact that we were operating in this territory without a license, and they had, I believe, exclusive license in that territory; I don't think it has ever been demonstrated that Liberty Glass Co. did not have exclusive milk-bottle rights in that section.

Mr. OLIPHANT. You mean in all of Texas?

Mr. COLEMAN. In all of Texas. The fact remains that there has never been a plant operated there with a milk-bottle license, and I dare say there won't.

Mr. COX. Go ahead and tell us what happened in the intervening time.

Mr. COLEMAN. We continued to make milk bottles and our sales increased naturally. We were selling practically the output of the plant. We had only one machine, and our output I would say was not over half of the demand in the State at the most. And we had three to five visits from various representatives of the Hartford-Empire Co. They sent us copies of their patents to explain just where we were infringing upon their patents. This went on for some time. In fact, we did not have the money to engage in any extended litigation with them, and, frankly, we tried every means possible to delay the thing and carry it along, to keep them away from us and out of court as long as possible, for I realized that we couldn't pay \$100 or \$150 a day to stay in the Federal court. Of course, they realized that, too. I believe it was in November or December of 1934 I came to St. Louis to discuss with the Obear-Nester Glass Co. the possibility of buying a Stuckey feeder. After quite a bit of difficulty they did discuss it with us. I think later on Mr. Knappe discussed it with Mr. Stuckey, and he was willing to sell us a feeder. However, they could give us no guaranty as to what Hartford-Empire Co. might do to us.

I came on to Washington to discuss it with the attorneys of the Florida Glass Co. whom Hartford was suing at that time for making milk bottles. These attorneys were patent attorneys attempting to work out some sort of feeding device that would not infringe upon the Hartford patents. However, I think that is impossible to do and I don't believe they ever got the feeder.

While here I was invited, as I mentioned awhile ago, to go to Hartford.

Mr. COX. What happened at Hartford?

Mr. COLEMAN. Well, it was a discussion—in fact I will say this: in all the talk that we had at Hartford, that I had at Hartford, they consistently refused to discuss even the remote possibility of a milk-bottle license in Texas. They could offer no explanation and denied at that time that the Liberty Glass Co. did have exclusive right, but they could not grant us one.

Mr. COX. They wouldn't even discuss that?

Mr. COLEMAN. No, sir.

Mr. COX. What did you say to them?

Mr. COLEMAN. Well, I think perhaps Hartford's experience in Texas had been more or less of a sad one. I think as a rule some Texans are resourceful people and I tried to impress upon them the fact—

The CHAIRMAN. The members of this committee have discovered that.

Representative SUMNERS. It takes a long time.

Mr. COLEMAN. I endeavored to impress upon them that we would fight with any weapons that we had at our disposal and that I thought that they were taking on more than they could handle, and I believe that after a fashion the fact that we did stay out of court for approximately a year after suit was filed made them hesitate suing us, they did not know what our resources were. It is an off-hand opinion of mine that the Hartford-Empire Co. had no desire perhaps to sue us, but the Liberty Glass Co. kept so much pressure upon them in the fact that they were taking this valuable sales territory, that they were forced finally in April of the next year to take this into the Federal court.

The CHAIRMAN. What year was that?

Mr. COLEMAN. In '35.

Mr. COX. You talked to Mr. Goodwin Smith there?

Mr. COLEMAN. Yes, sir. I discussed this with Mr. Goodwin Smith, and I guess with five or six others. They had a generous supply of attorneys. I will say this, that I tried to alter the scheme. My partner, Mr. Knape, had been up there a few months before, and it is a sort of variation of my understanding of the third degree to spend 1 hour in this room and 1 hour in the next room, and when he got back he was a nervous wreck, so I insisted I talk to all of them at one time and I have my health.

Mr. COX. Was anything said specifically to Mr. Smith about the situation in Texas?

Mr. COLEMAN. I did tell Mr. Smith (from his reaction perhaps he believed it) that in Texas within my lifetime I had seen men hanging in trees for doing less than what the Hartford-Empire was trying to do to my small company, and I was serious about it.

Mr. COX. Now what happened after that, after you went back to Texas?

Mr. COLEMAN. I returned to Texas and we continued to make milk bottles and to sell more milk bottles.

Mr. COX. Were you sued for infringement?

Mr. COLEMAN. We were sued for infringement of some 9 or 10 claims. I don't recall at the present time.

Mr. COX. Tell us about the outcome of that litigation.

Mr. COLEMAN. We naturally were finally forced to hire a patent attorney. We had to acquire the services of a Texas attorney, and I think there are some two or three patent attorneys in the State. They brought us into court in April of 1935, as I recall. Well, when I arrived in San Angelo and met them there in the hotel, I can conservatively say there was a half train load of attorneys and equipment. There were motion picture projectors and attorneys all over the place. I don't know anyone of the Hartford legal staff that was not there. They were prepared to give us a nice battle. Well, I had only one attorney and he was considerably lost in that crowd.

I wish you might have seen his face that morning. So I promptly asked for a recess until the afternoon, in order to see if we couldn't settle the case out of court.

Mr. COX. Did you settle the case out of court?

Mr. COLEMAN. We were able to settle the case out of court; yes, sir.

Mr. COX. What were the terms of the settlement?

Mr. COLEMAN. We received \$10,000 in cash and were allowed a 6 months' license on the milk bottles which we paid royalty on at that time for that 6 months' period. At the end of that period we were to ship these two feeders back to the Hartford-Empire Co.

Now, as I recall, we were granted the right, at the end of that time, if we wanted to make some of that packers' ware, they would let us use one of the feeders for that—a sort of slow death arrangement.

Mr. COX. At the end of the 6 months you discontinued the use of the machine?

Mr. COLEMAN. Yes.

Mr. COX. Were any milk bottles made after that?

Mr. COLEMAN. Yes, sir. The company at that time hired what is known as hand gatherers; where this glass flows by machinery to the flowing machine, these men dip into the furnace and get a quantity of glass and drop it into the mold. It is cut off with shears. It is a very ancient method, and expensive, as you can readily see. I think it requires about three men there constantly to do that work.

Mr. COX. Is that Knappe-Coleman Co. operating today?

Mr. COLEMAN. No, sir; it is not. The company operated approximately a year, perhaps. I wasn't with the company at that time. At approximately the time our agreement expired with the Hartford-Empire Co. on this license I left the company. However, they did continue to make milk bottles, and I will say a very good milk bottle. The element of cost was excessive. Negotiations were started. I don't remember whether the Knappe-Coleman Co. initiated them, or the Liberty Glass Co., but they were ready to buy the Knappe-Coleman Glass Co. and its assets because they had accomplished through their feeder arrangement the end they desired. They wanted to put the plant out of business and the fact that we continued to make milk bottles still made us a competitive sore spot.

Mr. COX. What are you doing now?

Mr. COLEMAN. I am assistant superintendent of the Coast Refining at Port Isabel.

Mr. COX. Would it be accurate to say that throughout your negotiations with Hartford-Empire you were prepared to take a license and pay royalties to them if they would permit you to make milk bottles and sell them in Texas?

Mr. COLEMAN. I would say we were always ready.

Mr. COX. I am finished, I think.

The CHAIRMAN. The Liberty Glass Co. is represented on the chart, "Exhibit No. 113,"¹ as one of the licenses of the Hartford-Empire?

Mr. COX. That is correct. It is one of the licensees of the Hartford-Empire which has, I believe, an unlimited right to make milk bottles.

¹ See appendix, p. 762.

Senator KING. Did you say "Liberty" or "Libbey"?

Mr. COLEMAN. Liberty.

The CHAIRMAN. Do any of the members of the committee desire to ask questions?

Senator KING. Who were the principal factors in the Liberty Co.? Do you recall the names?

Mr. COLEMAN. The president of the Liberty Glass Co. is Mr. Collins, Mr. George Collins, I believe.

Senator KING. Is that the Collins who was here?

Mr. COX. No.

Just a moment. How many men did you employ in the factory?

Mr. COLEMAN. We employed about 25 men, as I recall it.

Mr. OLIPHANT. What size town was it in?

Mr. COLEMAN. The population was 2,500, as I recall.

The CHAIRMAN. Mr. Arnold, do you care to ask the witness any questions?

Mr. ARNOLD. No.

Representative SUMNERS. What would it cost to equip a milk bottle manufacturing plant, a small unit, but one that would be commercially adequate?

Mr. COLEMAN. I would say, offhand, between \$200,000 and \$250,000; that is, to build an entirely new plant.

Senator KING. May I ask you another question: What kind of machine was it that you were operating?

Mr. COLEMAN. It was a Miller machine, which is a standard machine in milk-bottle manufacture.

Senator KING. It was not one manufactured by the Hartford Co.?

Mr. COLEMAN. No.

Mr. OLIPHANT. What would it cost to take some of the plants not in operation, and assuming no difficulty about patents or licenses, to equip it so as to employ a few of the people in a town of 2,500?

Mr. COLEMAN. Well, take for instance that plant there. If the forming equipment had not been moved to Sapulpa I would say fifty to seventy-five thousand dollars' worth of operating capital would keep the plant in operation until it was self-sustaining. I base those figures on the fact that we had no highly paid officers in our company. Whereas my salary was \$50 a week, I think Mr. Collins received three or four hundred. We had bought no plants ourselves. The sales of the Liberty Glass Co. have to include the \$100,000 paid for these two milk-bottle plants. That has to come back some way.

Representative REECE. How much did it cost you to go into business and get into a place where you were able to compete in the market?

Mr. COLEMAN. I would say \$50,000.

Senator KING. Could you buy the machines for that?

Mr. COLEMAN. That was in the nature of operating capital. I didn't mean by that the purchase of the plant.

Representative REECE. I intended my question to include the cost of putting the plant into operation.

Mr. COLEMAN. You mean a plant that is closed down. Is that the question—or to build a new plant?

Representative REECE. I was taking as a basis for my question your own plant. You did acquire the assets of another company and go

into operation and get into a competitive field where it appeared you were operating successfully. How much did it cost you?

Mr. COLEMAN. I would say we had involved some \$100,000 to \$125,000. However, at that figure I wouldn't say that we had too much capital. However, our chief difficulty in selling our merchandise was not the quality of our merchandise, but the fact that it was advertised by the Hartford-Empire Co., through the Liberty Glass Co., that we were just going to be in business long enough for them to get us in the Federal court. Naturally it is hard to get jobbers to take your merchandise when you are just going to be with them for a short time.

Representative REECE. How did your prices compare with the prices which had obtained before you went into the field?

Mr. COLEMAN. I say our prices were from \$1 to \$2 a gross, depending on the location, less than their prices, and that was not a cut-rate proposition. Most of our difference and savings within the State were based on freight differentials within the State. Sapulpa is some considerable distance from such points as Houston and El Paso, and even Fort Worth and Dallas, compared with where we were, 125 miles from Dallas, and they were 300 miles away and outside the State.

Mr. ARNOLD. The net result of this whole story is to compel people in Texas to buy glass from places outside of Texas and pay the freight.

Mr. COLEMAN. That is true.

Senator KING. Did you buy the machines, or have a license on the Miller machine? You said you took over the assets of the corporation.

Mr. COLEMAN. They belonged to the company. They had been bought outright. Here is the question involved on Miller feeders, as I understand. Miller, Hartford-Empire Co. claims, was infringing on their patents at the time he manufactured and sold the feeder, and in that manner gave a defective title when he sold them.

Senator KING. At any rate, the plant which you operated—

Mr. COLEMAN (interposing). We bought and paid for the feeders and thought they were ours.

Mr. DAVIS. Mr. Coleman, do you know whether there has been any court adjudication of the claims of the Hartford-Empire Co. with respect to infringement by the Miller machine?

Mr. COLEMAN. I don't have any knowledge of that. Most of those things stopped, as I recall, before the litigation could go on, by taking a license of some sort. Whether it has ever been settled I don't know.

The CHAIRMAN. Dr. Lubin?

Dr. LUBIN. No.

The CHAIRMAN. Mr. Coleman, who contributed this capital to your enterprise?

Mr. COLEMAN. They were Austin people—Mrs. Harrell, of Austin, Tex.; all residents of Texas. Mr. Knappe and myself were the managers.

The CHAIRMAN. What was the State of their residence?

Mr. COLEMAN. We were both Texans and educated in Texas.

Mr. COX. Where did the employees come from?

Mr. COLEMAN. With the exception of perhaps two or three men, they were all Texas people, local people. There were one or two experts necessary in the plant, like the plant superintendent; that was an

out-of-the-State man. However, he had worked in Texas for several years prior to that time.

The CHAIRMAN. With the exception of the machines themselves, where did the material come from which you were using in the manufacture of glass ware?

Mr. COLEMAN. That was one of the chief reasons for the plant location. At Santa Anna they have a fine deposit of glass sand; they call it a mountain there. It is about a 100-foot pile, actually, across the street from our plant.

The CHAIRMAN. You do magnify things in Texas anyway.

Mr. COLEMAN. Locally there was an unlimited deposit, almost, of natural gas that we were able to buy for 5 or 6 cents a thousand cubic feet, and we were on the main line of the Santa Fe Railroad there.

The CHAIRMAN. Is that deposit being worked now for the manufacture of glass?

Mr. COLEMAN. I don't know whether it is or not. While we were there there was some sand shipped, I believe; a plate glass plant operating at Wichita Falls bought sand from there.

The CHAIRMAN. What was the market in Texas for glass container ware?

Mr. COLEMAN. Well, I would say something like 300 cars a year, perhaps, of milk bottle business there in the State. That is not a great amount of business considering the size of the State. However, the business is concentrated in about, roughly, three cities—Fort Worth and Dallas and Houston, and I might say San Antonio.

The CHAIRMAN. In the negotiations which you conducted with the representatives of the Hartford-Empire after you received the invitation to go to Connecticut, was there any discussion of the issuance of a license to you to use the Hartford-Empire machine?

Mr. COLEMAN. That is for manufacturing milk bottles?

The CHAIRMAN. Yes; or any glassware.

Mr. COLEMAN. We attempted to discuss that with them any number of times, but they would not discuss milk-bottle licenses.

The CHAIRMAN. They would not under any circumstances?

Mr. COLEMAN. They offered no encouragement whatsoever as to milk-bottle license.

The CHAIRMAN. Were you offered a license on any other ware?

Mr. COLEMAN. Not at that time; no.

The CHAIRMAN. Were you later?

Mr. COLEMAN. Later, at the time of settlement—I mentioned the terms of settlement a moment ago—they told us we might if we saw fit use one of those feeders for packers' ware.

Mr. COX. That is what you call the slow-death process.

Mr. COLEMAN. Yes, sir.

The CHAIRMAN. So what it amounted to in the final analysis was that you couldn't receive a certificate of convenience and necessity from the Hartford-Empire Co. to operate a Texas plant with Texas capital to develop a Texas production.

Mr. COLEMAN. That is true.

Senator KING. Did Liberty have an exclusive license?

Mr. COLEMAN. As I recall, Mr. Smith said that no such agreement existed. Whether or not it is a written agreement, it is a matter of

fact that the agreement does exist, because no one has ever been allowed to operate down there except Liberty Glass Co.

Senator KING. I asked that question because you stated that Liberty seemed to be the organization that was pressing the suit.

Mr. COLEMAN. Yes, sir.

The CHAIRMAN. If there are no other questions, Mr. Coleman, you are excused.

(Mr. Coleman was excused.)

Mr. Cox. The next witness is Mr. Day.

The CHAIRMAN. Do you solemnly swear, Mr. Day, that the testimony you are about to give in this proceeding will be the truth, the whole truth and nothing but the truth, so help you God?

Mr. DAY. I do.

TESTIMONY OF GEORGE DAY, ATTORNEY AT LAW, DETROIT, MICH.

Mr. Cox. Mr. Day, will you give the reporter your name and address and occupation?

Mr. DAY. George Day, Detroit, Mich., attorney at law.

Mr. Cox. Mr. Day, at one time were you and certain other persons in Detroit, Mich., interested in establishing a glass factory there?

Mr. DAY. That is true; in the year of 1935.

Mr. Cox. Can you tell us very briefly the circumstances which created your interest in that enterprise?

REFUSAL TO LICENSE IN DETROIT

Mr. DAY. A client of mine had referred me to a man by the name of Howard who had been in the glass business all of his life, I presume, as a plant superintendent. At the same time another gentleman in Detroit by the name of Charles F. Clippert, in the brick business and vice president of one of our largest breweries, was interested in the formation of a glass plant, primarily to make beer bottles.

Mr. Cox. Why was Mr. Clippert interested in a glass plant?

Mr. DAY. At that particular time they were having difficulty in securing an ample supply of beer bottles from the regular manufacturers, and we found that was true not only with that particular brewery but with four or five others located in the city.

Mr. Cox. Do you know where the beer bottles come from, the geographical location of the factory they come from, that were being sold in Detroit?

Mr. DAY. I understand Obear-Nester of St. Louis and Owens-Illinois. I don't know the location of the plant that furnishes bottles there.

Mr. Cox. What steps did you take then in connection with this enterprise?

Mr. DAY. At that particular time the N. R. A. was in effect and we were notified that we would have to get permission from the N. R. A. before we could establish a glass factory.

Mr. Cox. Did you get that permission?

Mr. DAY. We did.

Mr. Cox. I want to ask you this before we go on with the story, Mr. Day. Were there any particular circumstances aside from the interest of these men you have mentioned a moment ago which made Detroit a good site for the operation of a glass factory?

Mr. DAY. I think I should qualify my statement. The glass factory was to be located in the village of Trenton, which is located 20 miles south of Detroit. It is ideally located because of the presence of the ingredients which go into the making of glass bottles. Silica sand was within 2 miles of our proposed location; soda ash; paper boxes for containers were all located within an area of 5 miles.

Mr. COX. Did you have fuel there?

Mr. DAY. Fuel was to be supplied by the Socony Vacuum Co. who had what was known as a waste gas which could have been supplied to us at a very low cost and which did contain a higher B. t. u. value than natural gas.

Mr. COX. Were you successful in raising capital for this venture?

Mr. DAY. We were successful in raising capital.

Mr. COX. Can you tell us approximately how much capital you had available for the enterprise?

Mr. DAY. We had the land turned in to the proposed corporation—we did not incorporate, we didn't get that far—and in addition we had approximately \$120,000 in cash.

Mr. COX. What steps did you take to carry on this enterprise after you had gotten approval from the N. R. A.?

Mr. DAY. We then met a gentleman by the name of William Schwenzfeier who was brought to my office. At that time he was an employee of Hartford-Empire Co. He was brought into my office by a former salesman of Obear-Nestor Co.

Mr. COX. And you discussed this project with Mr. Schwenzfeier?

Mr. DAY. We did. Prior to this time, of course, we had considerable work in getting our plans laid, what would be the cost of materials, and so forth. Mr. Schwenzfeier proved to be a very valuable man to us as far as advice was concerned.

Mr. COX. You were attempting at that time, I take it, to obtain glass-making machinery.

Mr. DAY. That is right.

Mr. COX. And as a result of your conversations with Mr. Schwenzfeier, did you talk to any other representatives of Hartford-Empire?

Mr. DAY. Not prior to that time, no. Mr. Schwenzfeier advised us it would be necessary for us to obtain a license agreement to operate glass-forming machinery anywhere.

Mr. COX. Did you attempt to get glass machinery from any other source except Hartford-Empire?

Mr. DAY. We had some glass machinery prior to the time we talked to Mr. Schwenzfeier. We obtained that through this man, Howard, who at that time was on our pay roll.

Mr. COX. What was that machinery?

Mr. DAY. We had two Lynch machines and one O'Neill machine.

Mr. COX. Did you have enough equipment to start the plant in operation?

Mr. DAY. We did, with the exception of a couple of lehrs which could have been obtained very easily.

Mr. COX. You could have obtained the lehrs?

Mr. DAY. That is right.

Mr. COX. So you had the machinery and your only problem was to obtain the right to use that.

Mr. DAY. That is right.

Mr. Cox. After you talked to Mr. Schwenzfeier, did you talk to other representatives of Hartford-Empire at any other time or place?

Mr. DAY. No; Mr. Schwenzfeier related our problem and story to Hartford-Empire direct, and after his conversation, I presume by correspondence, I received a wire from the sales manager of Hartford-Empire stating he would give us a further report.

Mr. Cox. Were you at any time invited to Hartford?

Mr. DAY. I was invited to Hartford; yes.

Mr. Cox. Now tell us what happened when you were invited to Hartford. Just tell us generally what happened.

Mr. DAY. I wanted to give the date. I was in Hartford, Conn., I think on February 9, 1936. At that meeting was Mr. Smith, Mr. Brown, Mr. Eldred, and Mr. Pease. The discussion, of course, was as to the advisability of going into the glass business, and the conversation throughout was very discouraging.

Mr. Cox. What did they tell you?

Mr. DAY. They told us, to begin with, that there was an over-capacity, and that there were no beautiful profits as we had anticipated, although we didn't anticipate "beautiful" profits.

Mr. Cox. What did you say in reply to this discouraging comment?

Mr. DAY. I had reports there of the past profits of various glass concerns and I told them that because of our location and the market, no freight rates to contend with, we could operate at a reasonable profit.

Mr. Cox. And you asked them at that time for a license?

Mr. DAY. I did.

Mr. Cox. And what did they say in reply to that request?

Mr. DAY. They indicated that they would not refuse us a license, but that they would rather not extend a license to us, pointing out that Owens-Illinois was very close to us, that if we did start a factory they no doubt would put in a warehouse and the competition would be too strong and we of course would be wiped out.

Mr. Cox. How long would you say in point of time this conference lasted?

Mr. DAY. I would say a couple of hours. They were very cordial.

Mr. Cox. And did you ask them more than once for a license?

Mr. DAY. I asked them directly just prior to the breaking up of that meeting and then later on directly in the form of a letter.

Mr. Cox. And they said they wouldn't refuse you a license, but when you left the meeting you didn't have a license.

Mr. DAY. That is true. However, they made a suggestion that they would not care to grant us a license direct but we could go out and buy up a couple of broken-down glass factories who had a license and we could obtain it that way.

Mr. Cox. What did you say in reply to that?

Mr. DAY. Of course, that is expensive. We didn't have the money to buy a plant and move it to Detroit.

Mr. Cox. Those were glass factories outside the State of Michigan?

Mr. DAY. That is right. I have some notes on a letter, taken at the meeting, and they were the Hart Glass Co., Dunkirk, Ind., and another one at Paden City, W. Va.

Mr. ARNOLD. You didn't need the equipment of these plants.

Mr. DAY. We needed a license agreement only.

Mr. ARNOLD. They knew you didn't need the machinery or equipment.

Mr. DAY. That is right.

Mr. ARNOLD. They were in effect suggesting you buy their license.

Mr. DAY. That is true.

Mr. COX. Now, I am going to hand you a photostatic copy of a letter and ask you if this is a letter which you in fact received from Mr. Pease of the Hartford-Empire Co. in 1936?

Mr. DAY. Yes, sir; that is a copy.

Mr. COX. This letter was received after the conference which you have just described?

Mr. DAY. No; that was just prior to the conference.

Mr. COX. This letter reads follows [reading from "Exhibit No. 154"]:

Since first receiving a report from Mr. Schwenzfeler relative to your proposition for a glass plant in Detroit, we here at Hartford have been giving the matter some serious thought.

Possibly we do not have the full story but from what we know of the glass industry in general being greatly overcapacitated, it does not seem to us feasible nor advisable to increase the tonnage that already exists.

If you and your associates care to come to Hartford, we will be more than pleased to get your story first-hand, but doubt whether our ideas will be altered.

I should like to offer this letter as an exhibit and call the chairman's attention to the fact that the handwriting on the side of the photostatic copy is a note the witness made.

Mr. DAY. That is true.

Mr. COX. It was not made by the department.

The CHAIRMAN. The witness testifies that this note on the side of this photostatic copy is one that he made in his handwriting upon the original copy?

Mr. COX. That is right.

The CHAIRMAN. The letter may be received.

(The letter referred to was marked "Exhibit No. 154" and is included in the appendix on p. 798.)

Mr. COX. Now, after this conference, did you have any more negotiations with Hartford-Empire Co.?

Mr. DAY. At the time that meeting broke up, Mr. Pease suggested that we give the matter further consideration. I returned to Detroit and my associates got together and we decided once more to ask them directly for a license for feeding devices. Then in reply to that letter, of course—that is my letter of February 28, where they want all of the available information which they already had in their hands, but it was a repetition of information that they had—

Mr. COX (interposing). I think that is not quite clear on the record, Mr. Day. You wrote them a letter asking directly for a license and they replied in a letter asking you for information which you had already given, is that correct?

Mr. DAY. That is true.

Mr. COX. Then thereafter did you obtain a license?

Mr. DAY. We did not.

Mr. COX. Why didn't you go ahead and operate the machinery which you had, anyway?

Mr. DAY. Well, the men going into the formation of that corporation didn't desire to continue with the proposal when we could

not receive a license agreement. That would be inviting, so we considered, a lawsuit.

Mr. COX. You didn't want to buy into a lawsuit.

Mr. DAY. That is true.

Mr. COX. And you have never at any time received a license from Hartford-Empire?

Mr. DAY. Never.

Mr. COX. Is this group in Detroit still interested in starting a glass factory?

Mr. DAY. They are still interested.

Mr. COX. Is the capital still available?

Mr. DAY. It is still available. I had a visit to my office yesterday of the same group of men who are interested in forming that company.

Mr. COX. These men are all Michigan men?

Mr. DAY. All Detroit men.

Mr. COX. And the capital is Michigan capital?

Mr. DAY. That is right.

Senator KING. Did they assign as a reason for refusing to give you a license that they had given exclusive licenses to other persons, and therefore they could not give you one?

Mr. DAY. No; that matter was not discussed. There was some discussion of the location of Owens-Illinois, that it was so close. However, there is not a warehouse or storage in the city of Detroit, or Michigan, that I know of, for glassware.

Senator KING. I had in mind whether or not they considered that as a valid excuse, namely, that they had given exclusive licenses to others and therefore were prohibited from giving you licenses.

Mr. DAY. No; that matter was not discussed.

Representative SUMNERS. What explanation was made as to why they wanted you to buy up a plant that was not operating as distinguished from giving you the right to operate under their license?

Mr. DAY. That then would give us a license agreement without interfering with their relationship between themselves and Owens-Illinois, or any other licensee.

Representative SUMNERS. Let's get that clear. Here are two plants you mentioned that are not operating. It was suggested that you buy one of the two nonoperating plants in order to have the privilege of operating their machinery in your plant at a different place.

Mr. DAY. What we would do is this: We would have to buy up that broken-down plant and move it to Detroit.

Representative SUMNERS. I know it, but what interest did Hartford have in requiring you to buy a plant that wasn't producing competition for anybody?

Mr. DAY. That would allow them to let us operate under that license agreement.

Representative SUMNERS. I am trying to find out why and how. Did they have an exclusive contract with one of these concerns that was not operating?

Mr. DAY. I couldn't say.

Representative SUMNERS. Did you go into that?

Mr. DAY. I did not. Their whole conversation was that they did not want to conflict with Owens-Illinois who was their licensee.

Representative SUMNERS. But how would you avoid conflicting with Owens-Illinois if you bought up the licenses of plants not operating and moved the license privilege to your own territory?

Mr. DAY. I don't know, unless that license agreement gives us the privilege of moving to Detroit, and I suppose it would.

Representative SUMNERS. That would conflict with the other glass people, wouldn't it?

The CHAIRMAN. If you had purchased the plant as was suggested to you, then the Hartford-Empire would have been in a position to say to Owens-Illinois and to Hazel-Atlas and to the Ball Bros. that it had not issued a new license.

Mr. DAY. That is right.

The CHAIRMAN. But had merely consented to the transfer of an old license.

Mr. DAY. That is right.

Mr. OLIPHANT. There would be no increase in outstanding licenses.

Mr. DAY. No.

Mr. ARNOLD. In mentioning the difficulties you might have in competing with Owens-Illinois, did they inform you one of the difficulties was that Owens-Illinois might share your royalties?

Mr. DAY. They did not.

The CHAIRMAN. Are there any other questions?

Mr. COE. I would like to ask the witness this question. Did you explore the possibilities of any other equipment at that time?

Mr. DAY. Yes; we did.

Mr. COE. What conclusions did you reach as to that?

Mr. DAY. The only possibility of securing any other machinery would of course be used machinery; no other new machinery.

Mr. COE. Did you explore the possibility of using the Owens suction feeder?

Mr. DAY. No; we did not.

The CHAIRMAN. The witness may be excused. Call the next witness please.

(Mr. Day was excused.)

Mr. COX. Mr. Kingsland. I am going to ask Mr. Cottone, of my staff, to examine him.

The CHAIRMAN. That will be quite acceptable.

Do you solemnly swear the testimony you are about to give in this proceeding will be the truth, the whole truth, and nothing but the truth, so help you God?

Mr. KINGSLAND. I do.

**TESTIMONY OF LAWRENCE C. KINGSLAND, PATENT ATTORNEY,
OBEAR-NESTER GLASS CO., ST. LOUIS, MO.**

Mr. COTTONE. Will you give your name and address?

Mr. KINGSLAND. Lawrence C. Kingsland. St. Louis, Mo.

Mr. COTTONE. What is your occupation, Mr. Kingsland?

Mr. KINGSLAND. I am a lawyer, specializing in patent practice.

Mr. COTTONE. What has been your connection with the glass industry, Mr. Kingsland?

Mr. KINGSLAND. I have represented the Obear-Nester Glass Co. since approximately 1928. I have been consultant in some other liti-

gations, including the Shawkee litigation, and in connection with the so-called Swindell litigation on the lehrs.

Mr. COTTONE. The Obear-Nester Co. is in the business of manufacturing glass containers, is it not?

Mr. KINGSLAND. That is correct.

RECORD OF AN INDEPENDENT

Mr. COTTONE. Can you tell us where the company operates?

Mr. KINGSLAND. They have a plant at East St. Louis, Ill.

Mr. COTTONE. And in what territory do they do business?

Mr. KINGSLAND. Widespread from that point, but, of course, mainly within that general area of the Middle West.

Mr. COTTONE. Can you tell us what position the Obear-Nester Co. occupies in the industry in terms of production?

Mr. KINGSLAND. My understanding is that they have approximately 2 percent of the container production.

Mr. COTTONE. Do you know how many people they employ?

Mr. KINGSLAND. I wouldn't know that.

Mr. COTTONE. Would about 450 be somewhere near the correct figure?

Mr. KINGSLAND. I would say, roughly, that would be correct.

Mr. COTTONE. Does the Obear-Nester Co. own any patents relating to glass machinery?

Mr. KINGSLAND. They have a number of patents. They have the so-called Stuckey patent on an air feeder; they have a construction that they are now using under that patent. They have some few additional improvements in shears, other apparatus relating to glass feeding.

Mr. COTTONE. The company is not a licensee of Hartford-Empire?

Mr. KINGSLAND. They are not.

Mr. COTTONE. They are shown on that chart, "Exhibit No. 113,"¹ over on the right-hand side.

Mr. KINGSLAND. That is correct. They never have been under a license under the present system of licenses.

Mr. COTTONE. Can you tell us what type of feeders the company uses?

Mr. KINGSLAND. At the present time they are using the so-called air feeder.

Mr. COTTONE. That is the so-called Stuckey air feeder?

Mr. KINGSLAND. It is represented by the Stuckey patent generally.

Mr. COTTONE. You own this machinery outright, do you not? You are not under any license arrangements with respect to it?

Mr. KINGSLAND. No; the machinery, the title, is owned by the company; it was constructed by the company under contract.

Mr. COTTONE. Over the past 12 years, the Obear-Nester Co. has been involved in certain litigation with the Hartford-Empire Co., has it not?

Mr. KINGSLAND. That is true.

Mr. COTTONE. And you have represented the Obear-Nester Co. in all this litigation?

Mr. KINGSLAND. I represented the company in all of the litigation except the initial stages of the first suit. That was in 1926.

¹ See appendix, p. 762.

Mr. COTTONE. Can you tell us about that first suit, Mr. Kingsland? Tell us when it was started.

Mr. KINGSLAND. The date of that first suit, the bill of complaint, as I recall it, was filed April 1926. That involved the so-called plunger feeder.

Mr. COTTONE. That feeder was in use by your company at that time?

Mr. KINGSLAND. The plunger feeder was in use and had been since 1922. The feeder had been installed early in 1922 and the suit was filed in 1926. There were two patents involved. There was a so-called phase-change patent, and the Steimer patent which was mentioned. The phase-change patent had to do with the timing of the shearing with relation to the extrusion of the gob. The Steimer patent related to the adjustment of the plunger.

Mr. COTTONE. Now, before that suit came to trial, did you do anything with respect to changing your equipment and machinery?

Mr. KINGSLAND. The equipment was changed about the time the suit was filed. As a matter of fact, it was in the process of change before there was any notice of the patent, and by the summer of 1926 the Obear-Nester Glass Co. had adopted the air feeder.

Mr. COTTONE. Did the Hartford Co. know of the installation of the air feeder?

Mr. KINGSLAND. They had a number of physical inspections of the air feeder. The fact of the matter is that in the original suit that was tried in 1928 the defendant at the time sought to involve the air feeder.

Senator KING. Did what?

Mr. KINGSLAND. Sought to involve the air feeder as it was then used, and bring that in so that the whole litigation would relate to what they were then presently using.

Mr. COTTONE. What was the purpose in involving the air feeders in that suit?

Mr. KINGSLAND. It was an effort to get this issue cleared in one litigation.

Mr. COTTONE. To prevent any new litigation on that issue?

Mr. KINGSLAND. That is right.

Senator KING. You contended that the air feeder was not in conflict with any legitimate patent that the Hartford Co. had?

Mr. KINGSLAND. That was the position.

Senator KING. Was that one of the Stuckey patents?

Mr. KINGSLAND. That was the air feeder, generally represented by the construction shown by the disclosure of the Stuckey patent.

Mr. COTTONE. Can you tell us now what the result of this suit was in the district court, the first suit?

Mr. KINGSLAND. The first suit resulted in a decree in favor of the plaintiff—that is, in favor of Hartford-Empire.

Mr. COTTONE. In other words, Obear-Nester was held to infringe the phase-change patent and the Steimer patent of Hartford-Empire.

Mr. KINGSLAND. That is correct.

Mr. COTTONE. And your company was enjoined?

Mr. KINGSLAND. Injunction was issued as against that construction, although at that time we were not using it.

Mr. COTTONE. Now, while this appeal was pending a second suit was filed?

Mr. KINGSLAND. That is correct. A second suit was filed involving four patents. All of the patents were predicated upon an air-feeder disclosure.

Mr. COTTONE. There were three Peiler patents involved in this suit?

Mr. KINGSLAND. Three Peiler patents and the Ferngren patent.

Mr. COTTONE. Can you tell us the date of that suit?

Mr. KINGSLAND. That suit, as I recall, was filed in 1929.

Mr. COTTONE. About February 25, would you say?

Mr. KINGSLAND. That date is correct.

Mr. COTTONE. And none of these patents had been involved in that first suit?

Mr. KINGSLAND. None of the air-feeder patents had been involved in the first suit.

Mr. COTTONE. And the suit was directed against the air feeder?

Mr. KINGSLAND. That is correct.

Mr. ARNOLD. Did you say you had tried to get the air-feeder patents inserted in the first suit?

Mr. KINGSLAND. We did.

Mr. ARNOLD. And were unsuccessful?

Mr. KINGSLAND. Yes, sir.

Mr. ARNOLD. Over the objection of the plaintiff?

Mr. KINGSLAND. Yes, sir; and that is shown in the subsequent litigation.

Mr. COTTONE. Was the Peiler phase-change patent that had been included in the first suit included in the second suit?

Mr. KINGSLAND. It was not included in the second suit.

Mr. COTTONE. Was there any attempt to include it?

Mr. KINGSLAND. Not on our part. They had selected, as we thought, the four air-feeder patents that were directed to what we were then currently using.

Mr. COTTONE. Did you feel that it should have been included in the second suit?

Mr. KINGSLAND. I felt all along there was no justification of directing it as against the air feeder.

Mr. COTTONE. What was the result of this suit?

Mr. KINGSLAND. The second suit resulted in favor of the defendant. Patents were held invalid in that by the district court. That case was appealed and on appeal was affirmed.

Mr. COTTONE. Do you have the citations?

Mr. KINGSLAND. I recall it, I believe, as 71 F. (2d) 539. I can check it.

Representative SUMNERS. Was there any attempt to bring that case to the Supreme Court?

Mr. KINGSLAND. In the second case the attempt was made to get to the Supreme Court on a petition for certiorari, and that was denied.

Senator KING. Those four last patents, the validity has been affirmed?

Mr. KINGSLAND. I think perhaps you have the wrong impression of my testimony. We were defending, and the four glass feeder patents

were held invalid. In other words, the decision was in favor of the Obear-Nester Glass Co., and the air feeder was thereby cleared from infringement of those patents.

Senator KING. I thought you said it was held valid, your patents.

Mr. KINGSLAND. Invalid.

Representative SUMNERS. When Mr. King interrupted—the first suit was directed against the use of machines which you were not at that time using; is that true?

Mr. KINGSLAND. At the time the suit was filed there were some of those machines in operation, but change-over to the air feeder, which we found to be more efficient, had been completed before the first suit was tried.

Representative SUMNERS. By the terms of the injunction issued?

Mr. KINGSLAND. We were not using the plunger feeder.

The CHAIRMAN. And what was the air feeder?

Mr. KINGSLAND. The air feeder was a feeder that is generally represented by the Stuckey patent, the Stuckey patent being a patent owned by the Obear-Nester Glass Co.

The CHAIRMAN. Issued when?

Mr. KINGSLAND. That patent was issued in 1928, but the application had been filed early in 1926, so that they were installed under the application before the patent issued.

The CHAIRMAN. That patent doesn't expire until 1945?

Mr. KINGSLAND. That is correct.

Representative SUMNERS. But the Stuckey patent issued to you— or did you have to acquire it?

Mr. KINGSLAND. We had the rights under the invention from the beginning and are now owners of the Stuckey patent. Stuckey was an engineer who installed or supervised the installation of the air feeders that we installed in 1926.

Representative SUMNERS. And that installation meant the right to use the machine, of course?

Mr. KINGSLAND. In a sense.

Representative SUMNERS. What I mean to say is, you were not in any conflict with Stuckey?

Mr. KINGSLAND. Oh, no; we were not in conflict with Stuckey. We were under the Stuckey patent.

Senator KING. He was the inventor, and you acquired his rights?

Mr. KINGSLAND. That is correct.

The CHAIRMAN. You were not under any license from Stuckey?

Mr. KINGSLAND. We had at the beginning a right to install the feeders and later acquire title to them. He was at that time an employee of the company.

The CHAIRMAN. So there was no limitation imposed upon the exercise or the use of this machine?

Mr. KINGSLAND. Not at all.

Representative SUMNERS. Now, have you ever licensed anybody else to use the Stuckey machine?

Mr. KINGSLAND. We have not; no.

Representative SUMNERS. Have you had any suits with reference to infringement?

Mr. KINGSLAND. As to the Stuckey patent?

Representative SUMNERS. Yes.

Mr. KINGSLAND. None.

Representative SUMNERS. Are they being used generally by anybody else?

Mr. KINGSLAND. I think that that specific form is probably only used, as far as we know, by the Obear-Nester Glass Co.

The CHAIRMAN. Is it now free of any threat of infringement suit?

Mr. KINGSLAND. No; that resulted in litigation that has recently been filed. I might explain that in this way, that after the air-feeder suit had been won by the Obear-Nester Glass Co. there was an effort made, after the accounting began, to throw the air feeder back in to the original suit. That was denied by the district court and was also denied by the court of appeals. Following the final decision in the air-feeder suit, which was the second suit, there was a motion filed in the first suit to extend the injunction to include the air feeder upon the contention that the air feeder had carried over certain apparatus that had been in the plunger feeder and that was denied and was taken to the court of appeals and again denied. Following that a new suit has now been filed against us in August of this year making the same contentions, although the air-feeder suit had been determined a number of years ago; but we are still under suit and have been with respect to that structure since 1926.

Mr. ARNOLD. You have been continuously sued since 1926?

Mr. KINGSLAND. Under continuous suits since 1926, with a brand-new suit now confronting us still in its initial stages.

Mr. ARNOLD. And one which, on the average of the other suits, will last several years, you think?

Mr. KINGSLAND. Beg pardon?

Mr. ARNOLD. Your guess is this new suit will last several years more?

Mr. KINGSLAND. Judging the future by the past, there will be a matter of a number of years before that suit may be determined.

Mr. COTTONE. The first suit is still pending, isn't it?

Mr. KINGSLAND. The first suit, I may say, is still pending on accounting and is in its initial stage on accounting on a reference.

Mr. COTTONE. In connection with that accounting, Mr. Kingsland, did you make any attempt to procure or bring into the proceedings the license contracts of the Hartford-Empire Co.?

Mr. KINGSLAND. In that accounting I made an effort to bring in the license contracts. I obtained an order from the master upon the theory they would be relevant because at the time there was a contention being made that a reasonable royalty would apply as a damage measure of recovery. The order was entered by the master and the plaintiff at that time entirely withdrew their claim for damage recovery. As a result of that the master held it to be irrelevant and we did not follow it.

Mr. COTTONE. In other words, as a result of their abandoning that attempt, the contracts were not brought into the proceedings?

Mr. KINGSLAND. On the matter of damages; but the case proceeded to one report and that report was set aside, and is back now for a re-reference and has been in that stage for the last 2 years.

Representative SUMNERS. May I ask this question? It is not clear to me yet. This accounting, is it with reference to the use of these patents prior to the time of the changes to which you refer?

Mr. KINGSLAND. That is correct. That goes back to the use in 1926.

Representative SUMNERS. Your answer was complete. Now, then, what is the chief ground upon which this last suit is based?

Mr. KINGSLAND. Well, it is an allegation that the air feeder as now presently used is an infringement of the first Peiler patent, the so-called phase-change patent. The contention is that we have carried over the phase change, although I might say that the Court of Appeals for the Sixth Circuit and my interpretation of the Court of Appeals of the Eighth Circuit is that that phase change is limited to a change while the machine is in operation. This last construction does not have that.

Representative SUMNERS. I didn't want to take too much time. Thank you.

Mr. COTTONE. Congressman Sumners brought up the question of the patents involved in the third suit; could that phase-change patent have been brought into the second suit? In other words, did the procedure or rules of the court permit the Hartford Co. to declare on that patent in the second suit?

Mr. KINGSLAND. Undoubtedly, it could have been involved in that case because the same situation existed then with respect to their allegation of infringement.

Mr. COTTONE. But the defendant would not be in a position to compel the inclusion in a situation like that?

Mr. KINGSLAND. As the law stood at that time, that is true.

Mr. COTTONE. There could have been an adjudication, in your opinion, of that patent in the second suit?

Mr. KINGSLAND. Had the plaintiff brought it in, we could not have forced it into the suit at that time.

Senator KING. As a matter of right, were you entitled to have that brought into the suit, or was it a matter of discretion for the court?

Mr. KINGSLAND. It was a matter of discretion whether the plaintiff should include it, because they had the patent with the same situation with respect to the alleged infringement at that time, as they have at the present day.

Senator KING. Was any abuse of the discretion involved, do you think? I don't want to lead you into criticism of the court.

Mr. KINGSLAND. I, of course, couldn't say what the policy was. My assumption is that they had four air-feeder patents, and since the device that we were then using at that time was an air feeder, I assume they felt they had sufficient in the air-feeder patents to support their allegation of infringement. But that issue was fought out, and, as I have indicated, was determined in favor of the defendant. It was only since that time that the allegation with respect to the first patent has been revised.

The CHAIRMAN. You may proceed.

Mr. COTTONE. Mr. Kingsland, have any attempts been made to settle these suits?

Mr. KINGSLAND. There have been no attempts as far as I know in any serious way to settle the suits. There have been conversations from time to time, but nothing you could really characterize as negotiations.

Mr. COTTONE. You have never been invited to go to Hartford?

Mr. KINGSLAND. No.

Mr. COTTONE. Now, do you have any opinion as to why these suits have been dragged out over a period of 12 years, Mr. Kingsland? Can you account for it in any way?

Mr. KINGSLAND. Well, I, of course, do not know what the reason is, except that we are outside of the fold of licensees; it is a fair assumption that to keep the licensees satisfied there have to be suits pending against those that do not happen to be within the fold. That is pure surmise.

Mr. COTTONE. I was thinking in terms of the length of time. Do you consider that the different strategic moves that have been made are designed as a harassing device?

Mr. KINGSLAND. It has resulted certainly in that, because we have been under constant litigation since 1926, substantially against the same construction we were using since that date.

Senator KING. Was there any delay by the plaintiff or by the defendants in that suit?

Mr. KINGSLAND. I would not say that there was any extraordinary delay in that suit. I think it was tried about on the schedule of the ordinary patent suit—that particular suit.

Senator KING. As defendant you wouldn't be interested in dragging it out—or would you?

Mr. KINGSLAND. We have been, Senator, from the very beginning, anxious to clear this issue of infringement.

Senator KING. I assumed that you were.

Mr. COTTONE. Has this litigation affected in any way the operations of the Obeart-Nester Co.?

Mr. KINGSLAND. I have no way of judging that, other than the difficulty of defense of litigation of this magnitude. They have gone right ahead with their business.

Mr. COTTONE. It does take the time of many employees, does it not, in the preparation of cases and trial of cases?

Mr. KINGSLAND. There is no question about that.

The CHAIRMAN. About how many employees are required to defend these suits?

Mr. KINGSLAND. Oh, engaged in the defense—that is, taking the employees—I should say that during the preparation of the case 8 or 10 major employees would be consulted.

The CHAIRMAN. It is continuous work, is it?

Mr. KINGSLAND. I would not say that; no. They continue to perform their ordinary functions.

The CHAIRMAN. Some witnesses who have appeared here have given an estimate as to the annual cost of litigation. Could you undertake to give that?

Mr. KINGSLAND. I could give the committee a general idea as to what this litigation over a period of 12 years has cost. It has cost in the neighborhood of \$200,000, exclusive of the time of the corporate employees, for experts, lawyers' fees, and matters of that kind.

Mr. ARNOLD. Is the fact that no one has asked you for licenses on your machine, do you think, due to this continued litigation?

Mr. KINGSLAND. I should say that would be a deterrent, certainly, to anyone who would attempt to go into the business.

Mr. ARNOLD. It is a pretty clear inference that if they took one of your machines they would also be subject to continued suit?

Mr. KINGSLAND. Because we are sued with respect to that construction.

Senator KING. Are you sufficiently advised to determine whether your patents and the products of your patents are as good as the products of the patents held by the Hartford Co.?

Mr. KINGSLAND. I am absolutely satisfied that they are, and our statistics show approximately a 5-percent increase in production.

Senator KING. So that your vendees, in buying your products, would be getting as good, if not better, products than those from the Hartford licensees?

Mr. KINGSLAND. I would not say a better product. The product is comparable, but the speed of production is somewhat increased by our air-feeder process, in my judgment, and as we have established by our own statistics and to our own satisfaction.

Mr. COE. Have all of these suits been confined to the sixth circuit?

Mr. KINGSLAND. They were all in the eighth circuit. The Obear-Nester Glass Co. is a Missouri corporation, and the suits have all been filed in Missouri.

Mr. COTTONE. The Obear-Nester Co. has been in a financial position to withstand this litigation over this 12-year period?

Mr. KINGSLAND. They are a strong company financially.

Mr. COTTONE. Did you know that the Owens Co. was contributing to the expense of prosecution of these suits against Obear-Nester?

Mr. KINGSLAND. No; that was never known.

Mr. COTTONE. Do you now know it?

Mr. KINGSLAND. I know it from reading the transcript of the testimony here.

The CHAIRMAN. May I interrupt? The chairman has been called away and I shall ask the vice chairman to preside in my absence. It is my understanding that you hope to be able to conclude with this witness in about 10 or 15 minutes.

Mr. COTTONE. Mr. Kingsland, in addition to the patents on which you have been sued, you have also been notified by the Hartford Co. that you have been infringing a number of other patents, have you not?

Mr. KINGSLAND. That is true. Subsequent to the time that the Obear-Nester Glass Co. succeeded in the second litigation, there was an additional notice sent to that company, including some 14 or 15 patents, part of them on the feeder section of the glass fabricating units and part of them on the so-called forming-machine section of the units.

Mr. COTTONE. Do you recall the date of that notice?

Mr. KINGSLAND. I can check it. My recollection is—

Mr. COTTONE (interposing). Is it August 2, 1934?

Mr. KINGSLAND. That is correct.

Mr. COTTONE. Has any suit ever been filed on the patents that were included in these various notices? Oh, by the way, do you know how many patents in addition to those on which you have been sued were included in those notices?

Mr. KINGSLAND. I think there were some 14 or 15. I haven't checked them because there were two notices. There was a 1928 notice and this last notice, but I think altogether about 14 or 15 patents that we have been notified about on which there has been no suit filed.

Mr. COTTONE. In that 1928 letter of infringement, was there included in phase-change patent, which was made the subject of the third suit?

Mr. KINGSLAND. The phase-change patent was included.

Mr. COTTONE. And that letter was dated prior to the second suit?

Mr. KINGSLAND. That is correct. I am saying that without checking those numbers, but that is my memory of it.

Mr. COTTONE. I have here the notices of infringement. These are documents that were supplied to us by the Obear-Nester Co., which consist of two notices of infringement dated February 14, 1928, and August 2, 1934. I am referring to that first letter, dated 1928.

Mr. KINGSLAND. In the 1928 letter was included the so-called phase-change patent.

Mr. COTTONE. That was prior to the institution of the second suit?

Mr. KINGSLAND. Yes. I do not recall whether that was repeated in the 1934 notice. I think it was not.

Mr. COTTONE. You said there were certain forming-machine patents that were included in that second notice. Is that so?

Mr. KINGSLAND. That is correct.

Mr. COTTONE. What kind of forming machines had the Obear-Nester Co. been using?

Mr. KINGSLAND. They are using a Lynch machine.

Mr. COTTONE. Where had it obtained these machines?

Mr. KINGSLAND. The Lynch machine had been obtained as early as 1922 on the market.

Mr. COTTONE. Purchased outright, not under any license?

Mr. KINGSLAND. Under no license.

Mr. COTTONE. Did you hear the testimony this morning with respect to the Lynch-Hartford-Empire contract relating to forming-machine patents?

Mr. KINGSLAND. I did.

Mr. COTTONE. Were you familiar with the arrangements under that contract?

Mr. KINGSLAND. I did not know the details. I knew that the Lynch Co. would not furnish machines.

Mr. COTTONE. Before you come to that, Mr. Kingsland, did you attempt to obtain any additional forming machines from the Lynch Corporation at any time?

Mr. KINGSLAND. We did, I think, in 1935-36.

Mr. COTTONE. Can you tell us the results of those efforts?

Mr. KINGSLAND. We were unable to obtain them. There was some correspondence covering the details of those negotiations.

Mr. COTTONE. I show you the correspondence to which you have referred, Mr. Kingsland, and ask you, without reading it into the record, to identify those documents and to indicate what they state.

Mr. KINGSLAND. The letter of June 29, 1935, to the Lynch Corporation, from the Obear-Nester Glass Co., asks that the Lynch Co. quote them on Lynch machines, three additional machines.¹ The reply to that was a quotation. The reply is dated July 1, 1935, and is a quotation with respect to the units inquired about, and the statement that a license would be required, not stating to whom application for the license should be made.²

¹ Subsequently entered as "Exhibit No. 155, see appendix p. 798.

² Subsequently entered as "Exhibit No. 156," see appendix p. 799.

Then, on July 6, 1935, the Obear-Nester Glass Co.—I should say on July 3, 1935—the Obear-Nester Glass Co. wrote again to the Lynch Corporation asking whether or not it was a prerequisite to the obtaining of the machines that a license be obtained,¹ and the reply on July 8 was that it would be necessary to obtain a license before we could purchase the machines.²

Senator KING. Was there any indication to whom you should apply for the license?

Mr. KINGSLAND. We applied to the Lynch Corporation, because they were the manufacturers of this machine at that date.

Mr. COTTONE. There was no indication in these replies of the Lynch Corporation as to the party to whom you were to apply for a license, was there?

Mr. KINGSLAND. No; but we knew generally what the situation in the trade was. We assumed it was Hartford.

Mr. COTTONE. You know the arrangements that existed between the Lynch Corporation and the Hartford Company?

Mr. KINGSLAND. We didn't know the details, but we knew there was some arrangement whereby a Hartford license would be required.

Mr. COTTONE. Did you attempt to obtain a license from the Hartford Co.?

Mr. KINGSLAND. We did not.

Mr. COTTONE. Will you tell us why?

Mr. KINGSLAND. Because we had been in controversy with them with respect to the feeders. We knew the licenses were coupled together and we were unwilling at that time, and still are, to come under that license system. We went out to the open market and bought second-hand machines to supply our needs at the time, and we are using those machines today.

Mr. COTTONE. You stated that there was no suit started on these forming-machine patents.

Mr. KINGSLAND. There were no suits filed on the forming-machine patents.

Mr. COTTONE. Have you received any information or indication that suits might be filed by virtue of your use of these old Lynch machines?

Mr. KINGSLAND. Nothing further than the notice, and that was dated—I believe you gave the date—August 2, 1934.

Mr. COTTONE. That is all, Mr. Chairman.

May I offer these four letters which Mr. Kingsland has identified?

The VICE CHAIRMAN (Representative Sumners). For the record?

Mr. COTTONE. They need not be printed.

Senator KING. Is there any controversy there? Should they be set out in the extension of the record?

Mr. COTTONE. I am perfectly willing that they should be identified and kept in the files.

(The letters referred to were marked "Exhibits Nos. 155 to 158" and are included in the appendix on pp. 798-800.)

Mr. COE. Mr. Chairman, there is one point I would like to have the witness clear up in my own mind. I understand the litigation against you has been confined to the eighth circuit. These patents

¹ Subsequently entered as "Exhibit No. 157," see appendix, p. 796.

² Subsequently entered as "Exhibit No. 158," see appendix, p. 800.

forming the basis of the suits against you—have they been litigated in any other circuit?

Mr. KINGSLAND. The phase-change patent has been litigated and the Steimer patent has been litigated. They were litigated in the sixth circuit in the Nivison-Weiskopf litigation, and also in the third circuit.

Mr. COE. Is there any conflict as to the validity of those patents?

Mr. KINGSLAND. There is a conflict, I understand. Even as between the eighth and sixth, the construction of the claims and the claims held valid do not agree. There is a contrariness of opinion between the two circuits with respect to the scope of the claims involved.

Senator KING. In those suits to which reference has just been made, was there an adjudication in favor of the validity of certain patents and the invalidity of certain other patents?

Mr. KINGSLAND. Claims of patents. Certain claims were held valid and certain claims were held invalid.

Senator KING. Were the Steimer patents held invalid?

Mr. KINGSLAND. It was held invalid in the sixth circuit and valid in the eighth circuit.

Senator KING. This isn't germane, but it seems to me it is very important to aid the committee in determining what sort of legislation, if any, is required. Don't you think that it is a very unfortunate thing that we have a system under the terms of which there may be different opinions with respect to the same patents in different Federal courts?

Mr. KINGSLAND. I think it would be a happy solution of the matter if it could be final, but as to the means of obtaining that I have no opinion at the present time.

Senator KING. Have you any objection to stating whether this plan would have merit, to provide that suits may be filed in the district courts, the Federal district courts, in any jurisdiction, and an appeal taken from that court directly to a court of patent appeals whose decision would be final unless a writ of certiorari or some constitutional question is raised, when the case might be carried to the Supreme Court?

Mr. KINGSLAND. That, of course, is quite a controversial subject at the patent bar, and I have no definite opinion on it. I see considerable advantage in it. I see some detriment. Taking and balancing the favorable outcome that would result from that and that that would not be favorable, I would say that it would probably be the best way to get this litigation terminated more quickly. I do feel, however, that if a plaintiff has a group of patents, that the simplest solution is to require him to put all of his patents into one suit against the single accused structure, which is a very simple way to handle it. That is my judgment about it.

Senator KING. Disassociating yourself—there is some facetiousness in this; it isn't meant by way of criticism—from the lawyers' cult, and considering only the interest of the inventor and the public, do you not think some plan should be devised under the terms of which these patent cases might be more expeditiously and cheaply determined?

Mr. KINGSLAND. I most heartily approve of that idea.

Senator KING. Would you have any objection to sending to the committee a memorandum making such suggestions in the light of your long practice, and of course your desire to serve the public, your views as to what changes should be made in the present patent laws? ¹

Mr. KINGSLAND. I should be very glad to give it real consideration and do what the Senator asks.

Senator KING. I would be very happy, and I think I can speak for all my brethren, for you to do that.

The VICE CHAIRMAN. It is a rather interesting thing, but that is exactly the thing I was going to ask you to do for the Committee on the Judiciary and for this committee, and I would like for the gentlemen here, the lawyers who have views and have been trained, to give us the benefit of their views in a fairly comprehensive memorandum, especially on the point that you suggested first, and that is, compelling the plaintiff to incorporate in his first suit all claims of known infringement—I mean, infringement that he knows as much about then as later on.

Mr. KINGSLAND. I feel very strongly that that would be a solution.

The VICE CHAIRMAN. That would have to be safeguarded, I suppose, but I think with proper safeguards you could do that, and I would like for the gentlemen who have other views to do that. I speak as the chairman of the Committee on the Judiciary in doing that. We get the picture of what this is all about, but the next thing, what are we going to do about it?

Senator KING. Mr. Chairman, may I say that the two bar-association committees, the national and the other (and they have committees on patents), have been asked by the chairman of the committee and myself to submit to this committee their views in regard to changes in the substantive law and particularly in regard to procedural matters, so that the committee may have the advantage of their views in the consideration of the testimony which will be adduced.

Mr. ARNOLD. And may I add to that a suggestion which the Anti-trust Division is peculiarly interested in, and that is the question of whether, under any patent law which provides for an equitable distribution between the inventor and the employer, there should not be the power to bring in the antitrust proceeding such uses of patents which actually restrain trade and competition to a serious and substantial degree, and I wish you would consider that, and I wish you would consider in that the fact that under the antitrust proceeding (and I think it is the only proceeding that I know about) each case of restraint on competition can be taken up on its own facts, and one at a time, which is, of course, not true under the more general matters of patents.

Mr. KINGSLAND. If there is anything I can add, I shall be very happy to do it.

The VICE CHAIRMAN. There is another thing that we haven't had time to go into, and won't take the time, and that is whether or not there ought to be compulsory issuance of a license. That is a pretty big question in this picture.

Mr. KINGSLAND. That is quite controversial at the present time.

Senator KING. There is a bill pending in Congress to that effect now.

¹ See memorandum subsequently submitted by Mr. Kingsland which appears in appendix, A29.

The VICE CHAIRMAN. Are there any other questions? Has anybody any questions to ask? If not, we will stand in recess until 2 o'clock. (Whereupon, at 12:22 p. m., a recess was taken until 2 p. m. of the same day.)

AFTERNOON SESSION

(The committee resumed at 2:10 p. m. on the expiration of the recess.)

The VICE CHAIRMAN. Are you ready, Mr. Cox?

Mr. COX. Mr. Meyers is going to do the questioning this afternoon.

Mr. MEYERS. I would like to call at this time the following representatives of the Corning Glass Works: Mr. Houghton, Mr. Falck, and Mr. Curtiss, and I would like them to be sworn in at this time.

Mr. HOUGHTON, will you please give your name and address to the recorder?

TESTIMONY OF AMORY HOUGHTON, PRESIDENT, CORNING GLASS WORKS, CORNING, N. Y.; TESTIMONY OF ALEXANDER D. FALCK, CHAIRMAN OF THE BOARD, CORNING GLASS WORKS, CORNING, N. Y.; AND TESTIMONY OF WILLIAM H. CURTISS, VICE PRESIDENT, CORNING GLASS WORKS, CORNING, N. Y.

Mr. HOUGHTON. Amory Houghton, Corning, N. Y., president, Corning Glass Works.

Mr. MEYERS. And Mr. Falck, will you do likewise?

Mr. FALCK. Alexander D. Falck, Elmira, N. Y., chairman of the board, Corning Glass Works.

Mr. MEYERS. Mr. Curtiss.

Mr. CURTISS. William H. Curtiss, Corning, N. Y., vice president and secretary, Corning Glass Works.

Mr. MEYERS. Mr. Houghton, you have been president of the Corning Glass Works since 1930?

Mr. HOUGHTON. Since February 1930.

Mr. MEYERS. You are also general manager of that company?

Mr. HOUGHTON. That is correct.

Mr. MEYERS. You are a director of the Empire Machine Co.?

Mr. HOUGHTON. Yes, sir.

Mr. MEYERS. The American Blank Co.?

Mr. HOUGHTON. Yes, sir.

Mr. MEYERS. And the Hartford-Empire Co.?

Mr. HOUGHTON. Yes, sir.

Mr. MEYERS. Mr. Falck, you are at present chairman of the board of directors of the Corning Glass Works?

Mr. FALCK. That is correct.

Mr. MEYERS. You were president of that company during the period 1920 to 1928?

Mr. FALCK. Yes.

Mr. MEYERS. You are president and director of the Empire Machine Co.?

Mr. FALCK. Yes.

Mr. MEYERS. The American Blank Co.?

Mr. FALCK. Yes.

Mr. MEYERS. You are director of the Hartford-Empire Co.?

Mr. FALCK. Yes.

Mr. MEYERS. Have you held any other position with the Hartford-Empire Co.?

Mr. FALCK. I am a vice president—have been since the Hartford-Empire Co. was organized.

Mr. MEYERS. Mr. Curtiss, you are vice president and secretary and a director of the Corning Glass Works?

Mr. CURTISS. That is correct.

Mr. MEYERS. And in addition to your duties as secretary you have general executive responsibilities, including supervision of the legal and patent departments?

Mr. CURTISS. Correct.

Mr. MEYERS. Contracts, licenses, and relations with all subsidiaries and affiliated companies, domestic and foreign?

Mr. CURTISS. Correct.

Mr. MEYERS. You are also a director of the American Blank Co.?

Mr. CURTISS. Yes.

Mr. MEYERS. Do you hold any position with the Hartford-Empire Co.?

Mr. CURTISS. I do not.

Mr. MEYERS. Mr. Houghton, what is the relationship between the Corning Co. and the American Blank and the Empire Machine Co.?

Mr. HOUGHTON. Do you wish me to give the American Blank first?

Mr. MEYERS. Please.

Mr. HOUGHTON. Corning Glass Works is an 80-percent holder of the common stock of the American Blank Co.

Mr. MEYERS. Who holds the remaining 20 percent?

Mr. HOUGHTON. The Empire Machine Co.

Mr. MEYERS. Does the Corning Co. own any stock in the Empire Machine Co.?

Mr. HOUGHTON. None.

Mr. MEYERS. Who owns that company, do you know?

Mr. HOUGHTON. There are seven stockholders; the control is in the hands of the Houghton family. Ninety percent of the common stock, including the stock I have just mentioned, is in the hands of stockholders of the Corning Glass Works, and 10 percent is held outside.

Mr. MEYERS. Who are the stockholders, generally speaking, of the Corning Glass Works? Would that be the Houghton family?

Mr. HOUGHTON. There are 403 stockholders of the Corning Glass Works.

Mr. MEYERS. Well, in terms of ownership, how much does the Houghton family own of the Corning Glass Works?

Mr. HOUGHTON. As you will see on your chart,¹ they own 40 percent. That added to the other stock coming from the estate of my grandfather adds up to a total of 52.2 percent, I believe, of the common stock of the Corning Co.

Mr. MEYERS. Now, who owns stock in the Houghton Associates?

Senator KING. Whom do you call the Houghton Associates?

Mr. MEYERS. That also is on the chart.¹

¹ See legend for "Exhibit No. 113," appendix, p. 763.

Mr. HOUGHTON. Houghton Associates is really an association of the stock in the Corning Glass Works from my grandfather's estate, entirely owned by my family.

Mr. MEYERS. Do you personally own any stock in the Hartford-Empire Co.?

Mr. HOUGHTON. Yes, sir; 500 shares, to be exact, I think.

Mr. MEYERS. Does the Empire Co. own any stock in the Hartford-Empire Co.?

Mr. HOUGHTON. Yes, sir.

Mr. MEYERS. What percentage of the total outstanding stock is owned by the Empire Machine Co.?

Mr. HOUGHTON. Forty-three percent.

Mr. MEYERS. Can you tell me how many directors on the board of Corning are also on the board of Hartford-Empire Co.?

Mr. HOUGHTON. Four of the Corning directors are on the board of Hartford-Empire.

Mr. MEYERS. And how many directors are there on the board of Hartford-Empire Co.?

Mr. HOUGHTON. There have been as a rule nine. I believe that due to a recent resignation, today there are only eight.

Mr. MEYERS. Mr. Falck, the Hartford-Empire Co. and the Corning Glass Works entered into a cross-licensing contract in 1922, did they not?

Mr. FALCK. They did.

Mr. MEYERS. Other parties to this agreement were the Empire Machine Co. and the Hartford-Fairmont Co.?

Mr. FALCK. Yes.

Mr. MEYERS. The Hartford-Fairmont Co. was the predecessor company of the Hartford-Empire Co.?

Mr. FALCK. Yes.

Mr. MEYERS. And the Empire Machine Co. is the company that we have just been discussing.

Mr. FALCK. Yes.

Mr. MEYERS. Now this 1922 agreement made a division between Hartford and Corning of certain pooled rights in glass formulas, machine patents and patent applications, then held and thereafter to be acquired by the parties to the agreement.

Mr. FALCK. Yes, sir.

Mr. MEYERS. Article 4 of that agreement sets forth the apportionment of the glassware divisions between Corning and Hartford, does it not?

Mr. FALCK. It is set forth in, I presume, article 4.

Mr. MEYERS. I believe you will find that on page 69 of the contract.

Mr. FALCK. Yes, article 4 contains the statement of apportionment of fields. It is called apportionment of fields, meaning the division or assignment to one company or the other of rights in a certain field of production of glassware.

Mr. MEYERS. Will you please explain, Mr. Falck, in layman language the nature of the ware fields in which Corning received exclusive and royalty-free rights?

Mr. FALCK. I can give you the nature of the fields in which Corning received exclusive rights, but I can't couple with that the statement that they were royalty free, because that is not correct.

THE SPECIALTY GLASS FIELD

Mr. MEYERS. Will you please give us the exclusive fields first?

Mr. FALCK. The exclusive fields, to paraphrase the lengthy description of them contained in the contract, were these: The first ware division was bulbs for electric lamps and other similar electrical uses. The second field related chiefly to the railway business, called the field of signal and optical glassware.

Senator KING. That wouldn't come under the category of the ware we have been discussing heretofore.

Mr. FALCK. Not at all.

The third field in which Corning has under the contract exclusive rights is what may be called the field of special resistance glasses—heat resistance, chemical resistance, and other special properties.

Mr. MEYERS. You have a trade name for that product, have you not?

Mr. FALCK. We have a trade-mark relating to heat-resisting glass, Pyrex.

Senator KING. Pyrex?

Mr. FALCK. Pyrex is the trade name generally applied to resistant glasses.

Senator KING. From whom did you get the exclusive right?

Mr. FALCK. That is dealing with the exclusive rights under the contract between Corning Glass Works and Hartford-Empire Co.?

Senator KING. Did the Hartford-Empire Co., as patentee or assignee of patents, have the rights under which you might obtain rights; under which the Corning Co. might obtain rights?

Mr. FALCK. We obtained exclusive rights under whatever Hartford's rights were in machines.

Senator KING. You conceded its superior rights to yours and became then an assignee or licensee of a company which you regarded as paramount to yours in that field.

The VICE CHAIRMAN. What you did, isn't it, was to pool your patents and then divide the right to use?

Mr. FALCK. There was no issue as to paramount rights. We granted exclusive rights under our patents for certain fields and took from them exclusive rights under their patent. It was a cross-license.

Mr. MEYERS. Will you proceed, Mr. Falck?

Mr. FALCK. The third field, as I have said, was the resistance glasses, and the fourth was specifically glassware intended for use as cooking vessels, for cooking food.

There were several other subdivisions where some of the rights were exclusive and some were nonexclusive. One of the exclusives was for a field of our operations, that is laboratory and chemical glassware, and the rest were minor, except for the field of drawn tubing and cane.

Mr. MEYERS. And drawn tubing and cane is the small glass container which houses the filament in a large electric bulb?

Mr. FALCK. That is small tubing or cane. It isn't limited to use in electric bulbs. We don't speak of it in the glass industry as a container; it is a tube or rod of glass; a stick of glass, if it is not hollow. If it is hollow, it is tubing.

Mr. MEYERS. These fields cover so-called specialty glassware as differentiated from glass container ware?

Mr. FALCK. Yes.

Mr. MEYERS. Will you please explain the nature of the fields in which Hartford received exclusive rights?

Mr. FALCK. It received under Corning's inventions the exclusive right to use them for the production of pressed ware and blown ware, and ware that is both pressed and blown, and the field was discussed between us as the container field. Generally speaking, that was the intention, to give Hartford Corning's right to use its inventions in the container fields.

Mr. MEYERS. And they got these exclusive rights from Corning to use certain patents that Corning had pooled in that agreement.

Mr. FALCK. They got the right to use whatever inventions Corning then owned or might make during the period specified in the contract, for the containers.

Mr. MEYERS. And that contract is still in force today?

Mr. FALCK. Yes.

Mr. MEYERS. And it has been amended from time to time.

Mr. FALCK. There have been minor amendments. Basically, there has been very little change.

The VICE CHAIRMAN. Does that right to exclusive use include the right to grant licenses to others to use?

Mr. FALCK. Yes.

Senator KING. Did the Corning Co. have a patent which would authorize them to manufacture milk bottles and beer bottles?

Mr. FALCK. The Corning Co. at the time this contract was made had no machine on which bottles could be manufactured. We had inventions that might by ingenuity be applied in the construction of some sort of machine. We had no machine working on the production of bottles or jars.

Senator KING. If you produced bottles or jars you would have to resort to the machines of the Hartford-Empire Co.?

Mr. FALCK. I should qualify what I have already said when I said that Corning gave to Hartford exclusive rights under its inventions for the container business; Corning retained a shop right to use its own inventions in its own shop, but gave to Hartford the rights beyond that and the right to sublicense others.

Mr. MEYERS. In other words, Hartford agreed to refrain from licensing others to manufacture on Hartford equipment those products which fell within Corning's exclusive fields, such as electric bulbs and heat-resisting ware.

Mr. FALCK. Generally speaking, the line of special glassware that we were then producing.

Mr. MEYERS. And likewise Corning disabled itself from manufacturing or licensing others to manufacture under the patents it contributed to the pool, products which fell within Hartford's exclusive fields, namely, any glass container products.

Mr. FALCK. No, Corning did not part with any right of manufacture in its own plants. It gave to Hartford-Empire the entire right except for that retained by Corning to use its own inventions in its own plant for any purpose, the container field or otherwise.

Mr. MEYERS. That is the shop right you have just mentioned.

Mr. FALCK. The shop right.

Mr. MEYERS. But Corning could not license others under its patents to manufacture, let us say—

Mr. FALCK (interposing). Not in the container field.

Mr. MEYERS. Mr. Falck, I wonder if you would explain briefly the factors which influenced the execution of this agreement in 1922.

Mr. FALCK. I shall try to be brief. It was a growth of acquaintance with the development work being conducted and accomplished by Hartford which began in 1916. In 1915 interferences were declared in the Patent Office between Chamberlin, who was an inventor employed by the Empire Machine Co., which was a Corning company, and Peiler, who was making inventions for the Hartford-Fairmont Co. The two groups then first learned of each other's existence through the interferences in the Patent Office and found after sufficient contact that our two inventors, widely separated geographically, were also interested in two quite different branches of the glass industry, Hartford being interested in developing apparatus for that part of the glass industry making containers which had no mechanical feeding devices, and Corning and the Empire Co. with its inventors particularly interested at the time in trying to develop automatic machinery for the production of bulbs which had all been hand production to that time. We found, therefore, that the ideas of these two men working for two different objectives had been declared by the Patent Office to conflict.

The two groups of executives and patent counsel in their meetings thereafter found that apparently Hartford-Fairmont Co., it then was, could be given our rights insofar as they conflicted with theirs in the Patent Office for use in the container field without depriving us of anything in which we were interested, and that likewise Corning could take from Hartford rights for bulbs and laboratory glass and signal glass, and so forth, without taking anything in which Hartford was interested. We therefore made a cross-license in 1916 which covered only the subject matter of those patent interferences, inventions then in existence and in the office.

From that time on we had contacts and began talking about this sort of contract as early as 1919, at which time Hartford had a better feeder and Corning very badly needed a feeding device for a fully automatic—and which was the earliest fully automatic-blowing machine for the production of bulbs, but which in Corning's hands had no feeding system, and needed one to supply the glass from the tank to the machine. As a result we made this contract which was again a division of rights along the lines of the fields of production in which Corning was interested on the one side, and the licensees of Hartford, the container industry, on the other.

Mr. MEYERS. Would you agree with what the writer of this memorandum said about that combination, that agreement? This memorandum is certified to by the Hartford-Empire Co., bearing the initials of F. G. S., dated January 30, 1919. Paragraph 4 reads:

Hartford or Empire, working alone as individual units will to some degree block each other on the question of patent rights. Whereas, working together on a basis of exchange of patent rights, the position of each singly or together would be greatly strengthened.

Mr. FALCK. That is not my statement of the situation, no; but substantially there is a great deal of truth in that. As I have already said, we made our first agreement because we were in interference in the Patent Office. We made our second agreement because there were other interferences in the Patent Office in sight. We thought that it would be wise to combine our small development organization with

Hartford's larger organization and have one organization whose efforts would be directed toward general glass machine development, and that we could safely contract to give Hartford container rights, Corning special glass rights, and it would strengthen both companies in that way.

Mr. MEYERS. I shall not ask you whether you agree with this statement. This is also from a memorandum certified to by the Hartford-Empire Co., bearing the name of F. G. Smith, dated March 16, 1920; it is entitled "Hartford-Empire Agreement." Paragraph 8 reads:

Any concern which can offer the use of automatic machinery and special formulas ought to eventually control the key to the glass industry in this country and foreign countries. Noncontrol of the formulas might permit formulas to be licensed to manufacturers not using our machines. Such manufacturers then might capture a large part of the trade of our licensees because of the superior quality of glass, and thus work untold injury to us.

Mr. FALCK. Well, if that is a fair question, I can't answer it. It is a complicated statement containing several thoughts. I have not seen it; I have not looked at it. If you want me to answer it in detail, I will try to do so.

Mr. MEYERS. What this statement means, does it not, is that if one company—

Mr. FALCK (interposing). I couldn't tell you what it means without its being read again, or my reading it carefully.

Mr. MEYERS. I show you that document.

Mr. FALCK. Do you want me to take these eight items, one by one, and say whether they represent my views?

Mr. MEYERS. You might read that document and tell me whether you have ever seen that statement before.

Mr. FALCK. Not to my knowledge; no. It may be quite all right, but I, off-hand, can't say that I agree with what you have read rapidly, and, so far as I know, I have never heard before.

Mr. MEYERS. That is perfectly all right, Mr. Falck.

Mr. FALCK. I don't know whether you read the first paragraph marked "1." Mr. Smith has written this, apparently, and it says—

1. Will strengthen our patent situation and preclude future differences of opinion regarding Empire and Corning rights under Empire agreement as well as under ownership of Steimer application.

I think that is all quite true and desirable. We had no wish to have patent litigation with Hartford so long as we could obtain, under their inventions as well as our own, rights to go ahead with our glass business, and we were quite willing, as we were not in the container business or interested in it in any way, to give them rights under our inventions for the container business.

Mr. MEYERS. I don't want to be argumentative about that document. It represents the thought of one of the responsible officers of a company which was a party to that agreement. You may disagree with it, and if you do, say so.

Mr. FALCK. I don't know, until I read what the sentences say.

The VICE CHAIRMAN. I think the witness has a right to make an examination of each of the statements and indicate his attitude on each of the statements.

Mr. FALCK. I have no objection to answering any of your questions, but this document was written in 1920 by Mr. Smith, 2 years before we made the contract, and is apparently directed to William

H. Honiss, his patent counsel. I don't know whether I ever saw it or heard it read before—probably not; but I think I am entitled to know what it says before I agree to it. Do you wish me to go on with it?

Mr. MEYERS. Yes.

Mr. FALCK (reading):

Second. If we proceed alone, is our present patent situation as strong as it should be and as we would like to have it?

I can't answer that. I suppose that was a question to their patent counsel in 1920. [Continues reading:]

Third. Will not the combined ownership of the patent rights dominate the Federal situation so as to preclude the Federal feeder becoming a competitor here in the States as well as across the water?

That also is a question to his patent counsel about which I know nothing. I am apparently reading parts that you didn't.

Mr. MEYERS. The other material is apparently extraneous to the point under issue, since your company had glass formulas, and the Hartford Co. did not.

Mr. FALCK (reading):

Any concern which can offer the use of automatic machinery and special formulas ought to eventually control the key to the glass industry in this country and foreign countries.

To the extent that that machinery and those glass formulas are all there were of machinery and formulas for use, I think it would control it.

Senator KING. Is that directed to your patent counsel?

Mr. FALCK. No; to the patent counsel of the Hartford-Fairmont Co., 2 years before we made the contract.

Mr. MEYERS. The report to the Department of Justice shows that the bulb and tubing division accounted for sales in the amount of approximately \$6,780,000.

Mr. HOUGHTON. That is correct for the year 1937.

Mr. MEYERS. And that accounts for what percentage of your total business—about 35 percent, roughly?

Mr. FALCK. I think that is approximately correct.

Mr. MEYERS. Your company manufactures clear-glass bulbs and inside frosted-glass bulbs to be used for incandescent electric lamps?

Mr. HOUGHTON. Yes, sir.

Mr. MEYERS. Can you tell me, Mr. Houghton, approximately what percentage of the sales of the bulb and tubing division is represented by the sale of bulbs to be used for incandescent electric lamps? Your bulb and tubing division is indicated in the answer to our questionnaire as taking in manufacture of incandescent electric lamps, radio tubes, and Neon signs, and I would like to know the volume of sales of electric bulbs for use in incandescent lamps.

Mr. HOUGHTON. I cannot give you that from my figures here, Mr. Meyers, in dollars. I can give it to you in thousands of bulbs, which I should think would probably be satisfactory. I have that figure here. In 1937, bulbs for use in incandescent electric lamps, 233,435,000.

Senator KING. Is that the total production in the United States or just the production of your company?

Mr. HOUGHTON. That is just the production of Corning Glass Works.

The VICE CHAIRMAN. What percentage of the domestic production or consumption is that?

Mr. HOUGHTON. That is 39.2 percent, sir, of the domestic production.

The VICE CHAIRMAN. How many other manufacturers are there of incandescent lamp bulbs?

Mr. HOUGHTON. We are talking about bulbs, Congressman—only one substantial one, so far as I know.

The VICE CHAIRMAN. Who is that?

Mr. HOUGHTON. That is the General Electric Co.

The VICE CHAIRMAN. You and the General Electric manufacture the bulbs used in the United States?

Mr. HOUGHTON. Yes, sir.

Representative REECE. What percentage of bulbs used in the United States are manufactured in the States?

Mr. HOUGHTON. Practically all of them. I think the last figure I saw was imports of maybe a million bulbs out of a total of 600-odd million, or 760,000,000.

Senator KING. Has the price of bulbs decreased from year to year?

Mr. HOUGHTON. Yes, sir; in 1913, for example—I just put these figures down thinking they might be asked for—a bulb for a 40-watt lamp was \$16 per thousand bulbs; in 1921 it was \$30; in 1925 it was \$18; and in 1938 it was \$8.10, roughly just a little more than a quarter of what it was in 1921.

Senator KING. As there has been a material decrease in the price has there been an improvement in the quality of the product?

Mr. HOUGHTON. Decidedly. In fact, the equipment that is being used today has to be designed for very accurate distribution of the glass as it is made so that the bulb can in turn be put on automatic lamp-making machinery.

Senator KING. Measured, if you may measure it, by the quantity of light which would be obtained by a bulb in 1913, how much would be obtained now by a bulb?

Mr. HOUGHTON. Senator, I would like to answer that, but I am not in the lamp business. We are only glass makers. The glass is substantially the same in transmission, possibly somewhat better, but that would be a question of what the lamp manufacturer did.

Senator KING. The improvement is largely in the carbon used in the manufacture—

Mr. HOUGHTON (interposing). I would rather not answer because I would just be guessing.

Dr. LUBIN. May I refresh myself on those figures you used? In 1913 it was \$16 and in 1935 it was—

Mr. HOUGHTON (interposing). In 1921 it was \$30. I haven't the 1935 figure here. In 1938 it is \$8.10.

Dr. LUBIN. When did the Japanese competition hit you people seriously?

Mr. HOUGHTON. I could not answer that, Dr. Lubin. It was several years ago.

Dr. LUBIN. About the time the price fell markedly?

Mr. HOUGHTON. Oh, no, sir; no sir. Our prices had almost a yearly coming down as we have been able to improve our efficiency.

Dr. LUBIN. Apparently sometime in '30 you were charging the same price you did in 1913, so the decline was from \$16 in '13—

Mr. HOUGHTON (interposing). The reason I showed the 1913 and the 1915 figures was that so often we talk of what things cost before the war and what they cost now. In the use of the modern machinery, your '21 figure, I think, is far more indicative, which shows a decline from \$30 to \$8.10 per thousand.

(Senator O'Mahoney, the chairman, resumed the chair.)

Mr. ARNOLD. Are these bulbs protected by a fairly substantial tariff?

Mr. HOUGHTON. No, sir. There is a tariff; I don't know what it is, but it is very small on electric-light bulbs. I want to be sure that I am talking the same language, because I am only talking about the glass that goes into the lamps. We are glass manufacturers and not lamp manufacturers.

Mr. ARNOLD. I may be going far afield here. I am simply interested in the point raised by Mr. Lubin about the Japanese competition. Was that competition in completed incandescent bulbs or in glass?

Mr. HOUGHTON. Practically entirely in the completed lamp.

Mr. ARNOLD. And it was the completed lamp thereafter that was protected by a substantial tariff?

Mr. HOUGHTON. I can't answer that, sir.

Mr. MEYERS. Does the manufacture of inside-frosted bulbs exceed the manufacture of the clear-glass bulb today? Is the inside-frosted bulb today a more popular bulb than the clear-glass bulb?

Mr. HOUGHTON. Yes, sir.

Mr. MEYERS. What is the percentage, would you say, in terms of sales?

Mr. HOUGHTON. I can give you our percentage, which I think is low, and that is—well, it is 121,000,000 frosted as against 111,000,000 unfrosted or clear.

Mr. MEYERS. Who controls the patent, who owns the patent, for making the frosting device which attaches itself to the bulb?

Mr. HOUGHTON. You mean who controls—I think the question is who controls the inside frost process, the patent on that. The General Electric Co.

Mr. MEYERS. And you are a licensee of General Electric Co. for that purpose?

Mr. HOUGHTON. Yes, sir. We have a limited license from them to manufacture.

Mr. MEYERS. Limited in what sense?

Mr. HOUGHTON. Limited in that we are—there is a specific list of lamp manufacturers whom we are licensed to sell. We are not prohibited from selling anyone, but we have not elected to take that chance.

Mr. MEYERS. That is, you are not prohibited if you want to encourage patent infringement action, or to fight patent infringement action?

Mr. HOUGHTON. I can answer that; yes.

Mr. ARNOLD. Let me get that perfectly clear. General Electric claims the right to—the exclusive right to the process, do they?

Mr. HOUGHTON. They have a patent covering the inside frosted bulb.

Mr. ARNOLD. And if you with any of your devices which you now have, do frost the inside of the bulb you would run into one of their claims?

Mr. HOUGHTON. I think it is not a question of device as much as it is a question of the basic etching, the method of etching the inside surface of the bulb. It is a product patent.

Mr. ARNOLD. Then they have agreed to allow you, without any threat of patent infringement, to sell to certain people?

Mr. HOUGHTON. Correct.

Mr. ARNOLD. And only to certain people?

Mr. HOUGHTON. Yes, sir.

Mr. ARNOLD. What is the reason for the limitation? Did they give any—

Mr. HOUGHTON (interposing). I will give you my reason. I can't give the General Electric's, but I think it is correct. We are licensed to sell to the General Electric Co. licensees in their lamp business.

Mr. ARNOLD. I think the reason is obvious, then, from that statement. I won't ask any further. And to no others except General Electric licensees?

Mr. HOUGHTON. Yes; to no others. But again I would like to point out that it is not a prohibition. It is purely a limited license to us to do certain things.

Mr. ARNOLD. I don't quite understand that. Why isn't it a prohibition? They claim that if you sell to other people you will be violating their patent, don't they?

Mr. HOUGHTON. They have not made that claim, but I think we would, sir.

Mr. ARNOLD. You think you would. Well, then isn't it in effect a prohibition?

Mr. HOUGHTON. I think not. I think it is an election of ours.

Mr. ARNOLD. You don't want to violate the patent, do you?

Mr. HOUGHTON. No, sir.

Mr. ARNOLD. And you have to make—

Mr. HOUGHTON (interposing). And that is the reason we haven't—may I take a minute?

Mr. ARNOLD. I am not trying to argue with you. It just isn't clear.

Mr. HOUGHTON. It is a fairly interesting situation. We had this license under the patent granted in 1928 and we sold only to this group, to whom we were licensed to sell. The lower court in Ohio decided against the patent and we immediately sold to anyone who wanted to buy inside frosted bulbs. The circuit court of appeals of that same district, which district I can look up if you are interested in it, sustained the patent at which time we decided to go back to our position of selling to only those to whom we were licensed to sell.

Mr. ARNOLD. I think I understand the situation. It is a choice between further litigation and accepting this limited license, isn't that it?

Mr. HOUGHTON. It is a choice, I suppose, made by us, that we do not want to infringe a patent.

Mr. ARNOLD. You are not convinced yet that the lower court was wrong and the court of appeals was right, are you?

Mr. HOUGHTON. I would rather express no opinion on that.

Mr. MEYERS. Mr. Houghton, your report for 1937 indicates the second highest sales division in your company is your housewares division, which accounts for sales in the amount of approximately \$2,269,000?

Mr. HOUGHTON. Our housewares division consists principally of ovenware, Pyrex. We market it under the trade-mark Pyrex. It is a glass cooking dish that can be used in the oven. There are other items in that line, number two being flame ware, which is a new development of ours for use over the top of the stove. That is really in its incipient stage; and then teapots and nursing bottles, and other miscellaneous items, but broadly speaking, Pyrex baking ware is the bulk of that business.

Mr. MEYERS. Yes; and that accounts for, as I said, something like \$2,269,000?

Mr. HOUGHTON. The total field which I described.

Senator KING. The gross sales, you mean?

Mr. MEYERS. Yes, sir.

Mr. HOUGHTON. That is the net sales to Corning, net return to Corning.

Mr. MEYERS. You mention the heat-resisting glass sold under the trade-mark Pyrex. Is it true that the two important patents owned by Corning on this ware expired in 1936?

Mr. HOUGHTON. Yes, sir; in May of 1936.

Mr. MEYERS. Now that these patents have expired, can licensees of Hartford-Empire go into the business of manufacturing heat-resisting ware on Hartford equipment?

Mr. HOUGHTON. No, sir; unless we license them, because we in the 1922 contract acquired exclusive rights in the heat-resisting field.

Mr. MEYERS. Do you recall the request made by the Indiana Glass Co. in 1937 to manufacture heat-resisting ware on Hartford machinery?

Mr. HOUGHTON. I don't, but I would like to look at my papers, if I may.

Mr. MEYERS. Here are certified copies from your files.

Mr. HOUGHTON. Yes, sir.

Mr. ARNOLD. I don't think the record is entirely clear as to why the Hartford licensees cannot manufacture Pyrex, in view of your statement that the patent on heat-resisting wares had expired.

Mr. HOUGHTON. In answer to that question they can. In answer to Mr. Meyers' question, he added Hartford.

Mr. ARNOLD. Then to make the record clear, the reason is that Hartford equipment is limited in its use to other wares by the Hartford license.

Mr. HOUGHTON. Because we have the exclusive rights in that particular heat-resisting field to the Hartford equipment; yes, sir.

Mr. ARNOLD. And therefore if they desire to manufacture heat-resisting wares on the expired patents, they would have to buy new machinery.

Mr. HOUGHTON. I don't quite understand your question.

Mr. ARNOLD. I don't either, quite; I mean I don't quite understand the situation. May I go back to clarify my own mind? The patents on the Pyrex—that is a trade name, the patents on heat-resisting ware have expired, have they not?

Mr. HOUGHTON. Yes, sir.

Mr. ARNOLD. Can machinery be purchased in the United States so that that process on which patents have expired may now be generally used?

Mr. HOUGHTON. I think the best way that I can answer that, I do not know whether it could be gotten, but our principal competitor is making heat-resisting glassware on automatic machinery that is not, I understand, under any Hartford-Empire patents.

Mr. ARNOLD. But it would have to be made on some machinery not furnished by Hartford-Empire.

Mr. HOUGHTON. Unless we elected to license.

Mr. ARNOLD. Unless you elected to license.

Senator KING. Did you manufacture the machinery which you use for your Pyrex, and if not, where was it obtained?

Mr. HOUGHTON. That is a question that would cover quite a bit of ground, Senator King. If we are talking of the baking ware alone, I think most of our equipment has been purchased outside. We use standard presses and we use the Hartford feeder, but it is an interesting sidelight, while we are on this, that only 32 percent of our total heat-resisting volume is made by Hartford equipment.

Senator KING. And the rest is made by—

Mr. HOUGHTON (interposing). The rest is made mainly by hand and some on our own equipment that we have developed.

The CHAIRMAN. And is that equipment of yours in use by any competitor?

Mr. HOUGHTON. I think not, sir.

Senator KING. But a competitor or some competitors do manufacture the same product.

Mr. HOUGHTON. Yes, sir.

The CHAIRMAN. And what devices do they use in addition?

Mr. HOUGHTON. I can't answer that.

Mr. MEYERS. In other words, Mr. Houghton, you did not grant Indiana Glass Co. permission to manufacture heat-resisting ware on Hartford equipment.

Mr. HOUGHTON. No, sir.

Mr. MEYERS. Do you recall, Mr. Houghton, that the Anchor Hocking Glass Co. attempted to engage in the manufacture of heat-resisting ware?

Mr. HOUGHTON. I have heard that they were contemplating it.

Mr. MEYERS. I would like to read at this time a letter to your company, dated November 20, 1937, signed "Goodwin," and addressed to you [reading from "Exhibit No. 159"]:

Eldred and Pease spent a day at Lancaster with Ike and Bill Fisher. Ike was in a pretty ugly mood about a number of things and, incidentally, he had samples of various kinds of baking ware and hard glass ware which had a bluish tint such as your top-of-the-stove ware.

All these samples had been made up by hand, and he had named this line of ware Fryrock.

Ike is going to defy us all in this kind of ware and use the same tactics that he is now using when he defies Hartford-Empire Co. on forming machine patents.

Do you know who Ike is, referred to in this letter?

Mr. HOUGHTON. Mr. I. J. Collins.

Mr. MEYERS. I should like to offer that letter for the record.

The CHAIRMAN. It may be received.

(The letter referred to was marked "Exhibit No. 159" and is included in the appendix on p. 800.)

Mr. MEYERS. Another letter certified as a true copy by your company, dated December 6, 1937, signed Bunn, bearing the heading

"Charles B. Belknap," addressed to "My dear Am." I suppose that is you, sir.

Mr. HOUGHTON. Correct.

Mr. MEYERS (reading):

With reference to the Pyrex situation, which you talked to me about in New York at our last meeting, have secured a promise from Ike that he would not start to market in that line without first discussing it with you and your associates.

Mr. Houghton, apparently Mr. I. J. Collins was interested in making heat-resisting ware.

Mr. HOUGHTON. Oh, Mr. Meyers, yes; you don't need to bring out those letters. Mr. Collins and myself have talked it over together.

Mr. MEYERS. Apparently you spoke to Mr. Belknap and Mr. Goodwin Smith about I. J. Collins' interest in manufacturing heat-resisting ware.

Mr. HOUGHTON. I had talked with Mr. Goodwin Smith because Mr. Collins had come to him, and Mr. Goodwin Smith had told Mr. Collins that he had no right, that it was entirely up to Corning. In the case of Mr. Belknap, I can remember one day asking him if he saw Mr. Collins to tell him I would like to have a talk about it when we next got together.

Mr. MEYERS. Anchor Hocking did not manufacture heat-resisting ware?

Mr. HOUGHTON. So far as I know.

Mr. MEYERS. If Anchor Hocking decided to use Hartford equipment in manufacturing heat-resisting ware, would it have been open to a patent-infringement action by the Hartford Co.?

Mr. HOUGHTON. By the Corning Co.?

Mr. MEYERS. No; by the Hartford Co.

Mr. HOUGHTON. Corning has exclusive rights. I suppose both might have been parties to suit.

Mr. MEYERS. At least Hartford could have revoked the license for engaging in the manufacture of a product which was in its schedule of exclusions.

Mr. HOUGHTON. I can't answer what Hartford's powers were; I do not know.

Mr. MEYERS. I think that is substantially so.

We introduced earlier this week a license agreement which indicated a schedule of exclusions,¹ and one of the most frequent exclusions is the heat-resisting-ware field.

As a practical matter, then, Mr. Houghton, the patent-pooling agreement, executed in 1922 between Hartford and Corning, permits Corning to maintain an exclusive position in the manufacture of heat-resisting ware, although the ware-formula patents have expired.

Mr. HOUGHTON. With the provision—under Hartford patents; yes.

Mr. MEYERS. It seems that this kind of arrangement is the one that was discussed in a memorandum dated August 13, 1930, entitled "Glass Revision. Rough Summary, to August 8, 1930," certified as a true copy by your company, and I read from page 6.

Now for practical purposes, I am, as I see it now, willing to support Corning's monopoly in bulbs, tube and cane, signal and optical, and cooking ware, with the backing of our patents—

¹ "Exhibit No. 120," supra, p. 408.

and "our" refers to the Hartford-Empire patents,

regardless of whether those divisions are at a given time covered by a Corning patent or whether the patent has expired. Equally I think it proper that our field, namely, the container field, broadly defined so as to cover practically all hollow ware except bulbs, signal, optical, and cooking ware, should likewise be supported by Corning's patents regardless of whether our feeder or other patents have expired or not.

Senator KING. Have you asked the witness whether he assents to that?

Mr. MEYERS. I am going into that. It seems that one of the most important advantages derived from a patent pooling arrangement is the protection afforded the parties when their own patents which they have contributed initially have expired. For example, you had a patent on a formula covering heat-resisting ware. That patent has expired, yet no licensee of the Hartford-Empire can manufacture heat-resisting ware on Hartford equipment because Hartford originally disabled itself from licensing its equipment for that ware in the original pooling agreement. Is that not true?

Mr. HOUGHTON. That is a very long question. Will you repeat that?

Mr. MEYERS. What we have are some patents on machine equipment. Your patents on ware formulas expired before the patents on machine equipment.

Mr. HOUGHTON. Correct.

Mr. MEYERS. Ordinarily, once a patent is expired, anybody can produce what was covered under that patent. Is that not true?

Mr. HOUGHTON. Anybody can produce what was covered under that patent.

Mr. MEYERS. Not Hartford licensees.

Mr. HOUGHTON. Hartford didn't invent the heat-resisting glass. That was an invention of Corning as a typical type of development. It was an entirely new business that was created by Corning, and Corning at a certain time in its development acquired exclusive rights for that field, for more modern methods of making it.

It made it possible for it over a period of years to widen that market very largely.

Mr. ARNOLD. This in effect extends the period of the heat-resisting ware patent, doesn't it?

Mr. HOUGHTON. No, sir.

Mr. ARNOLD. Well, if you are going to make heat-resisting ware, you have got to duplicate your machinery if you happen to be a Hartford licensee. Isn't that right?

Mr. HOUGHTON. If you are going to use Hartford equipment; yes, sir.

Mr. ARNOLD. And most of these people are using Hartford equipment, aren't they?

Mr. HOUGHTON. Most of what people?

Mr. ARNOLD. The people on that chart.¹

Mr. HOUGHTON. But we are talking now of an entirely different field, Mr. Arnold. This is not the container field at all. It is a special-glass field.

Mr. ARNOLD. But none of those people can enter into competition with you, although your patents expired, without going to enormous

¹ Exhibit No. 113, appendix, p. 762.

expense in duplicating machinery and getting machinery from some other source than Hartford?

Mr. HOUGHTON. I can't answer how enormous that expense is. Again I repeat that our largest competitor is adequately making it automatically, not under Hartford license.

Mr. ARNOLD. But at least these people are excluded without considerable expense. You will admit it must be considerable?

Mr. HOUGHTON. Unless we see fit to license them.

Mr. ARNOLD. Now, I am not saying this is illegal, because that is not the purpose of this inquiry, but, frankly, as a matter of fact, doesn't that, in effect, extend this expired patent so far as its practical effects are concerned?

Mr. HOUGHTON. It depends entirely on whether you are talking of the Hartford-Empire patent—yes; because we have exclusive rights. If they want to use other methods, they can do so, or if we see fit to grant a license if there should be reason therefor, it would change that picture.

Mr. ARNOLD. And you do have a very substantial control in the Hartford-Empire Co.?

Mr. HOUGHTON. Forty-three percent, I think I said.

Mr. ARNOLD. And four directors?

Mr. HOUGHTON. Correct, sir.

Mr. ARNOLD. Out of eight?

Mr. HOUGHTON. Nine, as a rule; eight now, but nine generally.

Mr. ARNOLD. So, admitting the question of legality, which I am not raising, this particular combination between the two companies has the effect of eliminating competition from a vast number of possible competitors who could come in if the combination did not exist.

Mr. HOUGHTON. May I go back again, Mr. Arnold, to my statement originally, that 32 percent of our dollar volume of sales in heat-resisting glass was made on Hartford equipment; the other 68 percent is open to any of those people, or any other glass manufacturers.

Mr. ARNOLD. If they will buy more machines.

Mr. HOUGHTON. No, sir. I am not talking about machinery now. I am talking about 68 percent of this heat-resisting business that is now open to anybody.

Mr. ARNOLD. I am not trying to argue, because I am honestly puzzled. You mean that there are other people not shown on that chart who have machines already which they can use to manufacture?

Mr. HOUGHTON. I am afraid I am clumsy in this.

Mr. ARNOLD. I may be clumsy. I am trying to get the facts.

Mr. HOUGHTON. What I am trying to say is that 32 percent of our heat-resisting business is made on the Hartford equipment.

Mr. ARNOLD. That is the Corning?

Mr. HOUGHTON. There is another 12 that is made on our own equipment, and the remaining 56 percent is not made on any patented equipment of any kind. It can be made by anybody, at any time, if they have the "know how" and want to put the investment into the making of heat-resisting glass which is entirely different from any other glass manufacturing.

Mr. ARNOLD. I think we are in agreement then, but to make it absolutely clear, let me restate it. The only hazard which you put on these people to prevent them from manufacturing heat-resisting

equipment is the fact that you compel them to go outside and buy new machinery for it and prevent them from making it on their existing machinery.

Mr. HOUGHTON. Well, they don't make it on their existing machinery because the entire development of the heat-resisting glass game has required very definite modifications of the existing machinery that you have been talking about most of the week.

Mr. ARNOLD. Then you would be willing to give up that provision limiting their licenses?

Mr. HOUGHTON. No, sir; I would not, because there is a patent right that we have. We have, however, Mr. Arnold, considered very seriously this question of licensing, and the last time that I talked with Mr. Collins I decided at that time we did not want to do it because we had made a very large investment in additional capacity, we had lowered our prices drastically, we were adequately taking care of the market in the business we had, and I could see no reason why we should be asked to grant a license to a person, whether it be the Anchor Hocking or somebody else just because they wanted it.

Mr. ARNOLD. I can quite understand that. I was thinking from the point of view not of Corning Glass Co. but a person interested in establishing the maximum competition. There would be a good reason from that point of view, wouldn't there, for establishing a policy different from what you have expressed?

Mr. HOUGHTON. You see, Mr. Arnold, in a business of the type we are in, I feel we are on the fringe of glass development; we are spending a good deal of money in development and this baking ware is typical of the kind of thing that is being done. Naturally other people would like to have licenses under that, and we have granted licenses in some cases, but we still hope we can reserve the right to decide whether we should license under our patents, but we try to look at it very broadly and make sure we are adequately covering the market and not holding it for the sake of holding it.

Mr. ARNOLD. Are you familiar with the cartel system in Europe?

Mr. HOUGHTON. In a very, very slight way.

Mr. ARNOLD. Those are substantially the reasons given for the existence of that system, allowing people to make agreements between each other to adequately cover the market, stabilize their business, and so forth.

Mr. HOUGHTON. I should hate to dispute that, Mr. Arnold, but I am talking now only of the rights under patents that we own. There is a distinction, I think.

Mr. ARNOLD. There is a distinction. In other words, the thing you are now doing is only possible under contract. I was only suggesting that you had something under patents which was very similar to the European cartel system under contracts. Do you think so?

Mr. HOUGHTON. I can't answer, although I am inclined to say no.

Senator KING. I am a little in doubt as to those who manufacture the other percent of this frosted glass. As I understood it, you manufacture with your own machinery and that which you are utilizing which has been furnished by the Empire, about 40 or 50 percent, and perhaps a little more, I don't recall. I was wondering where the machinery is obtained for your competitor who manufactures the same kind of glass.

Mr. HOUGHTON. Are you talking about bulbs again now?

Senator KING. Yes; the frosted bulb.

Mr. HOUGHTON. The frosting is a subsequent operation made on clear bulbs. The machinery on which we make clear bulbs was developed by Corning and is used by Corning and General Electric. That is not heat-resisting glass.

Dr. LUBIN. Mr. Houghton, I am a bit fuddled and I wonder if you can clarify this subject. You just said a minute ago to Mr. Arnold that you have seriously considered licensing your competitors in the field of what you call Pyrex glass, heat-resisting glass. You seriously considered licensing them to do what?

Mr. HOUGHTON. To manufacture and sell in that field.

Dr. LUBIN. But you say your patent has expired.

Mr. HOUGHTON. They can manufacture by any means except the Hartford equipment which we have exclusive rights to.

Dr. LUBIN. In other words, you seriously considered giving them a license to use machinery, patents on which are owned by somebody else?

Mr. HOUGHTON. That is correct, sir.

Mr. MEYERS. Mr. Chairman, I think that concludes the testimony of the Corning witnesses, if the committee has no further questions.

The CHAIRMAN. Mr. Houghton, may I ask you, so as to clear a situation in my own mind, with respect to the heat-resisting glass, assume a manufacturer which does not have a license under the Hartford-Empire machine, nor under your machine, is enabled to operate only under and by virtue of these other methods which you describe as being free to the industry, to what extent would such a manufacturer be able to compete with your organization?

Mr. HOUGHTON. I think I can best answer that, Mr. Senator, by saying that our largest competitor in this heat-resisting field—I am speaking specifically of baking ware because that was the one that Mr. Meyers started with—is manufacturing that on equipment that is not under Hartford-Empire license, I am sure, and he seems to be able to meet our competition and sell below us in many instances, and I have seen no signs of distress or unhappiness.

The CHAIRMAN. If there are no other questions—

Dr. LUBIN (interposing). May I ask one other question. This competitor you just mentioned, does he use Hartford-Empire equipment on making other types of products?

Mr. HOUGHTON. No, sir.

Dr. LUBIN. In other words, what if he were a licensee of Hartford, let's say, in making packers' ware and he wanted to produce heat-resisting glass under a process that he developed, an independent process, or by hand, would he be infringing upon the patents of Hartford-Empire?

Mr. HOUGHTON. Using Hartford-Empire equipment?

Dr. LUBIN. He is using that equipment, not in making heat-resisting glass, but in making other products. Then he goes into the development of heat-resisting glass and makes it by hand, let's say, hand presses; would he have that right and still retain the use of Hartford-Empire equipment in making packers' goods?

Mr. HOUGHTON. If I understood you correctly, under heat-resisting glass we have exclusive rights and he would not. The answer, I am told, is "yes."

MR. ARNOLD. Mr. Houghton, I want to ask you a question of policy which I only wish you to answer if you have thought it over because it is hypothetical. I am, however, interested in it if you can answer it. Suppose that your large competitor who is now happy should find his machinery has become obsolete because of a new invention which the Hartford-Empire Co. controlled, in that situation you are in a position of very substantial power with the Hartford-Empire. You would then be in a situation of refusing him a license and bettering the condition of your own company by limiting that competition. Do you think you would refuse him a license?

MR. HOUGHTON. Well—

MR. ARNOLD (interposing). That is so hypothetical I am perfectly willing to excuse you from answering.

MR. HOUGHTON. I will answer equally indirectly. You are talking now of our competitor?

MR. ARNOLD. I am talking about a chance of eliminating him because of your—

MR. HOUGHTON (interposing). We have offered him a license on baking ware which he has not seen fit to take.

MR. ARNOLD. Now, you would, however, discourage by your control over the Hartford Co. any other competitors than that one; that is your present policy?

MR. HOUGHTON. That is our present policy, for reasons which I think I have stated.

MR. ARNOLD. And the reason you would discourage them is that you think that you are in a position to look over this industry, determine the proper demand, determine the proper supply, and fix that according to your own judgment?

MR. HOUGHTON. I believe in the patent system, sir.

MR. ARNOLD. But do you think it should be extended that far, so you as a private individual could have all that power?

MR. HOUGHTON. I do, sir. When you come into the position of development like the glass game is in, if you recall it is within the last 40 years that the entire complexion of this game has changed; it has become mechanized, prices have gone down, and there is—any stimulus you can give to development in it, I think, is very important. I do think the man in the industry is in the best position to judge.

MR. ARNOLD. Therefore you think that the history of the glass industry is a closed book so far as other new competitors springing up?

MR. HOUGHTON. On the contrary, sir.

MR. ARNOLD. Well, insofar as you can make it a closed book?

MR. HOUGHTON. No, sir.

MR. ARNOLD. I am sorry; I thought your policy was not to grant licenses to these new people who would spring up.

MR. HOUGHTON. Mr. Arnold, you are generalizing, and I have been trying to talk about a specific problem.

MR. ARNOLD. I know; I am generalizing.

MR. HOUGHTON. I can't answer a general question like that, because I think each case must be specifically looked into.

MR. ARNOLD. You would say, however, that as we go to press, in the present situation it would be your policy to keep the people manufacturing heat-resisting ware down to the two who are now making it?

Mr. HOUGHTON. Well, as we go to press, yes; but I am not at all sure whether it will be tomorrow or the day after tomorrow, or a month from now, when there may be some different situation.

Mr. ARNOLD. You see, I am making a distinction. I can quite understand that representing stockholders, and from that point of view making all the money you can for them, the policy of keeping the competition out, if it is a legal thing to do, is perfectly explainable. I was talking to you from the point of view of public policy, whether you should have that power, and you think you should, as we go to press?

Mr. HOUGHTON. Yes, sir.

Mr. MEYERS. Mr. Houghton, in answering Mr. Lubin's question, whether you have a competitor, you said you have in the field of manufacturing heat-resisting ware; what is the name of that company?

Mr. HOUGHTON. McKee Glass Co.

Mr. MEYERS. They do not use Hartford-Empire equipment?

Mr. HOUGHTON. I believe not.

Mr. MEYERS. Do they operate under the same formula covering a heat-resisting ware that you operate under?

Mr. HOUGHTON. I can't answer that. They are free to. The basic patents expired in 1936.

Mr. MEYERS. But you have licensed them, have you not?

Mr. HOUGHTON. Those licenses expired in 1936.

Mr. MEYERS. Have you a trade-secret agreement with them?

Mr. HOUGHTON. None, sir.

Mr. MEYERS. That is all.

The CHAIRMAN. The witnesses may be excused.

(The witnesses were excused.)

Mr. Cox. Mr. Belknap.

The CHAIRMAN. Mr. Belknap, do you solemnly swear the testimony you are about to give in this proceeding shall be the truth, the whole truth, and nothing but the truth, so help you God?

Mr. BELKNAP. I do.

TESTIMONY OF CHARLES B. BELKNAP, EXECUTIVE VICE PRESIDENT, OWENS-ILLINOIS GLASS CO., TOLEDO, OHIO

The CHAIRMAN. You may be seated, Mr. Belknap.

Mr. Cox. Will you tell the reporter what your present occupation is, Mr. Belknap?

Mr. BELKNAP. Executive vice president, Owens-Illinois Glass Co.

Mr. Cox. Mr. Belknap, are you a director of the Owens-Corning Fiberglas Corporation?

Mr. BELKNAP. I am.

Mr. Cox. To satisfy my curiosity, Mr. Belknap, will you tell me why Fiberglas is spelled with one "s"?

Mr. BELKNAP. It was a coined name.

Mr. Cox. Is this document which I hand you a true and correct copy of the contract between the Owens-Illinois Glass Co. and Corning Glass Works for the formation of the Owens-Corning Fiberglas Corporation?

Mr. BELKNAP. It is.

Mr. COX. If you have no objection, I should like to have this marked as an exhibit. I have no desire on my part to have it printed.

The CHAIRMAN. The contract may be marked as an exhibit and filed with the committee.

(The contract referred to was marked "Exhibit No. 160" and is on file with the committee.)

Mr. COX. Will you tell us, Mr. Belknap, what the business of the Owens-Illinois Fiberglas Co., or rather, the Owens-Corning Fiberglas Co., is?

GLASS FIBER AND WOOL

Mr. BELKNAP. The Owens-Corning Fiberglas Corporation was formed to carry on the development work with the hope of making a commercial operation which would support itself and develop a new industry in the United States in making fiber glass.

Mr. COX. Do you have some samples here that the committee may see so that they can understand what fiber glass is?

Mr. BELKNAP. I have.

Senator KING. It is like silk, isn't it?

Mr. BELKNAP. It is, Senator.

Senator KING. Is that the product of this company?

Mr. BELKNAP. It is.

The CHAIRMAN. Are these the price marks?

Mr. BELKNAP. No, sir; I am not a salesman.

The CHAIRMAN. You may proceed.

Mr. COX. It is true, is it not, that the stock of the Owens-Corning Fiberglas Co. is owned in equal shares by the Corning Glass Works and Owens-Illinois? Is that approximately correct?

Mr. BELKNAP. That is approximately correct. I think in the organization papers 15 percent was set aside for the management.

Mr. COX. That is a Delaware corporation?

Mr. BELKNAP. It is.

Mr. COX. Prior to the organization of the corporation, Mr. Belknap, is it true that the Owens-Illinois Co. had for some period of time been engaged in developing and doing experimental work in connection with the production and use of this material?

Mr. BELKNAP. We started in '30 or '31 to develop this.

Mr. COX. What is the material designed to be used for? Can you tell us, Mr. Belknap?

Mr. BELKNAP. It is designed to be used for places where the dielectric qualities of glass are useful, where the chemical-resistant qualities of glass are useful, where the heat resistant qualities of glass are useful. It may eventually go into other uses, such as draperies, but because it is a higher-priced material than most of the material that it is competing with, we attempt to confine its use to those places where its qualities give it a chance to succeed against cheaper materials.

The CHAIRMAN. What are these small balls?

Mr. BELKNAP. They go into the forming machines and become 98 miles of fiber.

Mr. COX. That process which the chairman described is covered by certain patents, is it not?

Mr. BELKNAP. It is covered by certain patents and a great many applications which our employees have made, and some 30 issued patents.

Mr. COX. Would it be accurate to say that most of the patents prior to the organization of the Fiberglas Co. were owned by Owens-Illinois Co.?

Mr. BELKNAP. That is correct.

Mr. COX. Under the organization agreement would it also be accurate to say that the Owens-Illinois Glass Co. and the Corning Glass Works transferred to the new company, the Fiberglas Co., all of their patent rights so far as they related to the production of this material, and all rights which they might have under contract relating to patent rights?

Mr. BELKNAP. That is correct.

Mr. COX. Prior to that time, it is true, isn't it, that the Owens-Illinois Glass Co. had interests in certain contracts with foreign interests with respect to patents relating to the production of this material. Is that correct?

Mr. BELKNAP. We have entered into contracts with foreign people to use this particular process.

Mr. COX. And under those contracts, would it be accurate to say that you grant them a license under your patents and patent rights, and they in turn have granted you a license under their patents and patent rights?

Mr. BELKNAP. Yes; we considered that that type of license is necessary to protect not only our own investment but our own employees in this country.

Senator KING. What is the status of the law? I think there is a Federal statute under the terms of which licenses between nationals, American nationals, may be made; that is, reciprocity between other companies and the United States in the matter of patents. Do you recall?

Mr. BELKNAP. I don't recall any law which makes it any different than a contract between citizens of the United States, excepting something that would relate to national defense, or something of that sort.

Mr. COX. Mr. Belknap, would it be accurate to say that under those contracts you obtained an exclusive license under the patents of the foreign interests which I shall hereafter refer to as the foreign patents, with your permission, and that you gave them an exclusive license under your patents for the particular material which is involved?

Mr. BELKNAP. That is correct. We not only give them an exclusive license but we also give them our technical knowledge and have, as a matter of fact, had our employees in Europe for months training operators.

Mr. COX. I want to be sure I am clear about this. Under those contracts you obtain exclusive right for certain territory under their foreign patents. Is that correct?

Mr. BELKNAP. That is correct, as to the people we license.

Mr. COX. One of those license agreements is with a Dutch company, is it not, Mr. Belknap?

Mr. BELKNAP. It is.

Mr. COX. Mr. Belknap, I am now going to take an unfair advantage of you. I want you to tell me what the name of that Dutch company is. I have been waiting to hear somebody pronounce it.

Mr. BELKNAP. After about 4 years, I am still unable to pronounce it.

Mr. COX. We will just call it the Dutch company, then.

The CHAIRMAN. You might spell it.

Mr. COX. I am not sure I want to try that.

One of those contracts was with an Italian company, was it not?

Mr. BELKNAP. It is.

Mr. COX. And one of them is with a French company, is it not?

Mr. BELKNAP. It is.

Mr. COX. And one of them is with a company which is located in Scotland, is that correct?

Mr. BELKNAP. It is. That is Chance Bros.

Mr. COX. I spoke a moment ago of a Dutch company. As a matter of fact, there are two Dutch companies with whom you have such contracts.

Mr. BELKNAP. There are. One of them is a licensee for Holland alone, and the other is a general licensing company, located in The Hague.

Senator KING. You in return get licenses from foreign countries to utilize their patents in the United States?

Mr. BELKNAP. Yes, sir; we do, Senator.

Senator KING. And do other manufacturers in the United States obtain patents obtained in foreign countries, so far as you know?

Mr. BELKNAP. I think that is quite customary.

Mr. COX. Mr. Belknap, just so the record may show now the exact standing and scope of these contracts, would it be true to say that with one of the Dutch companies you have a contract which gives them an exclusive license under your patents for Germany and Holland and its colonies, in return for which you obtain an exclusive license from them under their patents?

Mr. BELKNAP. That is correct.

Mr. COX. And in the case of the Italian company, the exclusive license you grant to them is for Italy, its colonies and possessions?

Mr. BELKNAP. It is.

Mr. COX. And in return you get an exclusive license from them under their patents?

Mr. BELKNAP. Yes, sir.

Mr. COX. And in the case of the French company the exclusive license you grant is for France and its colonies and possessions, and in turn you receive an exclusive license from them?

Mr. BELKNAP. From those companies that hold our license; yes, sir.

Mr. COX. And in the case of Chance Bros. & Co., Ltd., you have granted an exclusive license for the British Empire and British mandated territories with certain named territory excluded; is that correct?

Mr. BELKNAP. That is correct. Canada is the one I chiefly think of.

Mr. COX. And in the case of the other Dutch company you have granted an exclusive license for the remainder of the world, is that correct?

Mr. BELKNAP. We have granted them the right as a licensing company to grant licenses in the remainder of the world.

Mr. COX. That is in all parts of the world, not covered by your other license agreements?

Mr. BELKNAP. That is correct.

Mr. COX. And that is an exclusive right on their part?

Mr. BELKNAP. It is.

Mr. COX. And in return in each of these cases the license which has been granted to you is an exclusive license for certain designated territory, is it not?

Mr. BELKNAP. Yes; to this extent, we provide in the license that anyone who gets the advantages of our machine and our technical knowledge, we must get their patents back for the United States and Canada, and I believe Mexico.

Mr. COX. South America included, or do you recall?

Mr. BELKNAP. No; South America is licensed by the Dutch company, but we do share in the royalties.

Mr. COX. So your rights are exclusive under the foreign patents for Canada, United States, and Mexico, but not for South America?

Mr. BELKNAP. That is correct.

Mr. COX. And in the case of South America the Dutch company may license there and you divide the royalties, is that correct?

Mr. BELKNAP. That is correct.

Mr. COX. Now, Mr. Belknap, I have here a document which we obtained from your files and which has been certified by your company, which purports to be a copy of your contract between your company and the Italian company. I wish you would examine it and see if you are satisfied that it is a true and correct copy of that contract.

Mr. BELKNAP. It is.

Mr. COX. Mr. Belknap, I want to read to you a provision from this contract and then ask you a question about that provision in relation to the other contracts, so I will try to read it as carefully as I can. It is contained in section 13 [reading from "Exhibit No. 161"]:

Modigliani agrees that it will not export and will use its best endeavors to prevent the exportation from its territory of—

(a) Fibers as such made under rights covered by any part of this agreement.

(b) Fabrics, the major part of which are fibers made under rights covered by any part of this agreement.

(c) Articles, in which the value or mass of fabrics contained therein or forming part thereof and under such agreement constitute more than 25 percent of the value or mass of the completed article.

And further agrees that in granting licenses in the field of this agreement it will impose the above obligations.

Fabrics or articles falling within the field of this agreement, the exportation of which are not to be prohibited by this article, may be imported into any country notwithstanding that either party hereto holds a patent on an invention within the field of this agreement covering such article or the fiber contained therein or processes of producing the same.

You understand that article?

Mr. BELKNAP. I understand it, but I would like to make an explanation about it, if it is satisfactory.

Mr. COX. I would be glad to have you do that. May I ask one question before you do, Mr. Belknap? Would it be accurate to say that the other contracts to which we have referred contain a provision, either identical with or similar to, that provision?

Mr. BELKNAP. That is correct.

Mr. COX. That is correct. Now, Mr. Belknap, if you wish to make a statement about the provision, it is perfectly all right.

Mr. BELKNAP. The inclusion of a nonexport clause back into the United States is one of the things which is very difficult in trying to

deal with foreign licensees. The American patent system requires the full disclosure when you file your application. Therefore, if you do not file abroad the issuance of the United States patent throws all of your work open to people in Europe, who can in turn come back into the United States. We select our licensees with the idea that we will give them our knowledge and that in return for that we get the benefit of the developments which they make, and we have included the nonexport clause so as to prevent our being estopped from certain United States patents against them. It is a problem that has bothered me for several years, as to how to deal fairly on that particular subject.

Mr. Cox. I should like to have this contract admitted in evidence and again I suggest that it not be printed, but merely be certified.

(The contract referred to was marked "Exhibit No. 161" and is on file with the committee.)

The CHAIRMAN. It may be so admitted. You have read into the record the material or a section of this contract.

Mr. Cox. I want to be sure that I understand that to the effect of that provision. Mr. Belknap, would it be correct to say that under that provision the prohibition against imports from the territory covered by the license agreement extends to articles made not only under your patents in foreign countries, but under the patents of the company with which you have the agreement?

Mr. BELKNAP. That is correct in this particular art. The technical knowledge as to the glass and surface treatments of the glass is probably much more important than the patented part. We are trying to develop not a patenting system but a business, and I think that some provision is necessary to prevent the people who obtain your know-how from taking that and using it on some other process and thereby turning back into America the results of the American's work.

Mr. Cox. Now one more question and I think I shall have finished, Mr. Belknap. Whatever the reasons may be for the inclusion of those provisions in the contract, if I should suggest to you that it seems to me that the effect of the provision is to establish a kind of private tariff system, would you object to that characterization?

Mr. BELKNAP. I think I would, for this reason, Mr. Cox. Glass fibers have been known in America, at least prior to the World's Fair in Chicago in 1893, and they have been manufactured both in America and abroad for probably—well in excess of 50 years, and we have taken during the depression years and invested about three or four million dollars in a new industry, and I think we have a right in licensing other people not to do what they will do with things other than our own licensees, but I think we not only have that right but that we have that duty.

Mr. Cox. One more question, Mr. Belknap. You speak of glass fiber having been manufactured for a considerable number of years. The old process, in your opinion, is not as efficient or likely to be as commercially successful, is it, as the process which is covered by your patents?

Mr. BELKNAP. I would not think so.

Mr. Cox. I think that is all I have to ask.

The CHAIRMAN. Mr. Belknap, I have been reading this section to which Mr. Cox called your attention. The first paragraph reads as follows [reading from "Exhibit No. 161"]:

Modigliani agrees that it will not export and will use its best efforts to prevent the exportation from its territory of (a) * * * (b) * * * (c) * * *

What did Owens expect the Italian company to do under that provision, by which it was bound to use its best efforts to prevent exportation?

Mr. BELKNAP. We expected that if they licensed the Fiat Co., for example, which is engaged in making electric wire, among other things, in Italy, if they sold this fiber to them that they would not take that produce, that they would require the licensee to follow that insofar as the laws of their country will permit. I think their country will permit the question of control of resale. I do not think that is true in the United States.

The CHAIRMAN. Of course there is another provision in this section which reads [reading further from "Exhibit No. 161"]—

and further agrees that in granting licensees in the field of this agreement it will impose the above obligations.

So apparently there are two covenants made by the Italian company; well, there are three. One, that it will not export these items itself; two, that it will use its best efforts to prevent the exportation of these items; and three, that in granting licenses in the field it will impose this obligation upon the licensees, so that apparently the covenant is much broader than licensees', is it not?

Mr. BELKNAP. I think that is correct, Senator. It is quite customary in Europe to form sales companies which handle the selling rather than the manufacturing company, even though they may be owned by the same people.

The CHAIRMAN. Was the Italian company expected by the terms of this contract and by your understanding of it to go outside of its own licensees and try to prevent generally, by competitors or others, the exportation of these items?

Mr. BELKNAP. No; not by any competitors there. Solely by the people that they furnish the materials to. I might use as an example, if this material becomes efficient for curtains, draperies, where fire-proofing is needed, as in hospitals, if the Italian company could take our material and sell it to a company which made drapes in that country without anything, I question if the American textile companies would have any business; if they can make fibers by any other process than those that we have in this country, we are perfectly willing.

The CHAIRMAN. Now, in explaining the adoption of this contract, you testified, as I understood you, that when a United States patent is issued it becomes in effect open to all the world, unless the patentee files for a patent in the other country?

Mr. BELKNAP. I didn't intend to give that impression. I meant that it became open to everybody, and the people in the other country could manufacture under it and ship the product into the United States if we hadn't taken a patent whereby we could control.

The CHAIRMAN. In other words, the situation which you describe is this: That Congress, to which the Constitution of the United States

has given the power to regulate foreign commerce, has not imposed any restriction upon foreign countries, and in this particular field you have undertaken by this contract to impose that regulation of foreign commerce which Congress has not imposed?

Mr. BELKNAP. We have attempted to do so, and I hope rightly, but if it is not a proper provision, then I think an American company has no alternative but to keep their processes secret and not deal with foreign countries.

The CHAIRMAN. I think that inference is quite justified. I was just developing the situation. Thank you very much.

Mr. PATTERSON. Mr. Belknap, the evidence during the past few days has revealed that the glass industries in this country are the lowest cost producers. What, in your judgment, is the main reason for this?

Mr. BELKNAP. Because they are willing to spend the money to hire technical graduates to develop their machinery to a higher extent than they are abroad. We have had license with the German people on bottle machines abroad for a great many years, and I do not recall receiving a single invention from them that we have incorporated in our machines. There may have been one or two minor things.

Mr. PATTERSON. In other words, it is research work?

Mr. BELKNAP. It is research work.

Mr. KING. And you have more efficient employees, do you not, and utilize a larger amount of electric energy in your plants than they do in other countries?

Mr. BELKNAP. I think that is true, Senator. In this particular glass wool field, we probably have 100 graduates of technical colleges working on this one problem.

Mr. KING. My recollection, since I looked into it, is that assuming that Germany or England utilizes one—I will give that as a unit to follow—in an activity, we utilize three or four.

Mr. BELKNAP. Probably greater than that. Certainly it is in the glass industry.

Mr. ARNOLD. Mr. Kettering, of General Motors, testified, as I remember, in regard to the patent law that a concern of any considerable size interested in manufacturing would have to do this research work anyway and would do it anyway. Would you agree with that statement?

Mr. BELKNAP. I would agree with him if he was referring to an established business, but we would have to go out of business; we couldn't afford to put three or four million dollars into a new business.

Senator KING. This corporation of which you have been speaking was organized only for the purpose of manufacturing this glassware that you have exhibited to us here?

Mr. BELKNAP. That is the sole purpose, to develop that product and manufacture it.

Senator KING. And the expenditure was made of several million dollars in order to bring about that result?

Mr. BELKNAP. That is correct.

Senator KING. Are you continuing your experiments?

Mr. BELKNAP. We are continuing our development work and experiments and making what commercial sales we can to help carry part of the cost.

Senator KING. Have you found sufficient sales yet to compensate you in part at least for the expenditures which you have made?

Mr. BELKNAP. I think that was true in 1937. We had enough volume so that we carried about \$375,000 of the \$750,000 experimental cost in that year.

Senator KING. Was there any purpose in your foreign patents to build up a system under the terms of which the tariff laws might be ineffective?

Mr. BELKNAP. I think not, Senator. I think our sole interest is to be freed from interference with patents and be able in the United States to manufacture and sell this product.

Senator KING. Did you fear any competition in this product from foreign corporations, assuming there was no tariff? In other words, did you consider that your production, your development of the industry, of the art, had reached such a high degree of perfection that you had no fear of any foreign competition, even though you might give them your patents or permit them to utilize your patents?

Mr. BELKNAP. Unfortunately our contracts provide for the technical information and therefore their people have the right to it. If we didn't have that I wouldn't fear it at all.

Mr. COX. Mr. Belknap, you have testified that this glass fabric—do I understand you to mean your patents include your methods of producing that old article?

Mr. BELKNAP. They cover not only the method but they cover the form of the peculiar surface treatment of the glass which enables it to be drawn into a much finer form than it was ever drawn, and we have some patents which cover the finest of the fiber itself.

Mr. COE. Does an American patentee have protection, one who has a patent on a process only, have protection against the fabrication of that article by that process abroad and importation into the United States?

Mr. BELKNAP. That is the question that I believe is unsettled. I think there have been one or two cases in which we have stopped in the tariff the admission of material made abroad on a process which would be covered in the United States, but I would question that that is an established law in this country, although it is in most foreign countries.

Representative REECE. If you were unable to restrain the production of a commodity under your patented process then the product could be produced by a foreign concern and imported into this country in competition with your plant here, and further American capital, American technicians, and American machinery, which as you say is more highly developed than machinery made for this purpose abroad, could be exported and produce this product which could be reimported in competition to yours.

Mr. BELKNAP. I think that is peculiarly true in a material of this type. A boatload of that would have an entirely different value from a boatload of bottles.

The CHAIRMAN. It amounts to saying that when the patent law was originally passed, Congress did not foresee the wonder of technical development which has taken place in our time and made no provision to protect American genius and American inventions from such a condition, and you have undertaken to do it by a contract of this kind.

Representative REECE. And if you were unable to do so you might lose the enjoyment of the benefits of your patent.

Mr. BELKNAP. If we were unable to do so I think we would have to operate strictly on a secret process.

The CHAIRMAN. I think that inference is quite justified.

Mr. COX. Have you applied for any patents in foreign countries under your processes for producing this material?

Mr. BELKNAP. A great many of them.

Mr. COX. Of course, if you had a patent in a foreign country except for the engineering services which you offer the foreign interests that patent in the foreign country would afford you protection against the use in the foreign country of your process, would it not?

Mr. BELKNAP. Yes, it would.

The CHAIRMAN. Are there any further questions? We are very much indebted to you, Mr. Belknap. You may be excused.

Mr. ARNOLD. Mr. Chairman, that concludes the presentation, that is the oral presentation by witnesses of the material which the Department of Justice desired to present under the resolution. I want to say in that connection that our idea was to select a typical example of an aggressive use of the patent privilege, and a nonaggressive use of the patent privilege. That we have selected the glass industry is not because we considered it outstanding or because we considered it the only example of this kind of practice, but because we considered it a typical example.

To fill out the entire picture within the limits possible in a committee of this kind, we would like to have leave to submit memoranda concerning other industries which can be considered by the committee, keeping the practices we have gone into detail here in mind, and we hope by that means to fill out the general picture of the patents used in restraint of trade.

I want finally to say that we appreciate the attitude of the glass people particularly because, of course, there has been no secret about a very pronounced difference in point of view of the social utility of the restraint of trade indicated here between the glass people and not the committee but the Department of Justice in the courts, of the antitrust laws, and in spite of that they have given us every cooperation, they have let us into their files and they have come here at considerable trouble, and we are sorry, of course, that they had to be selected but some industry had to be picked and we can assure them that they were not picked because they were the worst.

Mr. COX. Before the committee adjourns, the chairman will recall that Mr. Safford, of the Hartford-Empire Co., and I had a colloquy this morning with respect to a letter which that corporation addressed to the Lynch Corporation in 1936.¹

I offered at that time, if I could find a copy of the letter, to introduce it in the record. I was successful at the noon interval in finding a copy of the letter, which I now offer. It is a letter dated March 11, 1936, to the Lynch Corporation, Anderson, Ind., signed by the Hartford-Empire Co., and apparently prepared by R. D. Brown, their patent counsel.

Mr. Goodrich has agreed with me—

¹ *Supra*, p. 605, et seq.

Mr. GOODRICH (interposing). That is the one we saw right after the recess?

The CHAIRMAN. You had better identify Mr. Goodrich. He has not been called as a witness.

Mr. COX. He did some little testifying yesterday afternoon.

The CHAIRMAN. For the benefit of the record let it be shown that Mr. Goodrich is an attorney for the Hartford-Empire Co.

Mr. GOODRICH. I'm sorry; I don't think that is the one.

Senator KING. While they are making that investigation I would like to make this comment upon the suggestion made by Mr. Arnold. It seems to me that is a very wise provision which he has suggested, but it seems to me that in all fairness, when the memoranda have been submitted and examined, I assume they will be made public, and if so, the companies or individuals to which the same may relate should have the opportunity, if they desire, to appear before the committee or submit such countervailing testimony as they may desire.

The CHAIRMAN. The resolution, Senator King, as I understand it, authorizes the various departments which are represented upon this committee to present evidence to the committee, either by way of public hearing or by way of memorandum or report. That is a proceeding authorized by section 3 (b), and, of course, the committee in its executive session, when it was considering the method of procedure, seemed to be of the unanimous opinion that when the time came to determine what the future course of the committee would be under section 2 it would consider to what extent further public hearings would be necessary to present countervailing evidence; but I think it is quite agreed that all of these reports which may be submitted will be public and can be examined by all persons who are interested.

Senator KING. I did not want the idea to become prevalent that we were having testimony in camera and denying persons to whom the testimony referred presenting their views.

Mr. ARNOLD. I am glad you made that clear, Senator. It may make a further observation on my part useful for the record. Any memoranda which we submit to supplement the picture which we have now given will be fully documented. We will try to so arrange them that any parts of those memoranda about which the committee may desire further testimony may be taken up in part. We are adopting that method only because it is obviously impossible to conduct on all industries as elaborate a hearing as we have on this.

Mr. COX. I think you should state, also, Mr. Arnold, that we have not at all exhausted the evidence which we have collected upon the glass industry; that we propose to file a report which will cover not only the material which has been presented orally here, but other material which we have collected, and the observation that Senator King made will, of course, apply to that material.

Senator KING. May I say that when the matter was first under consideration by the committee I indicated that it seemed to me that very much of the matter that we were investigating might be brought to our attention by memoranda, by statements which the various departments might prepare and present, but at the same time I stated that if that were the case and we were not satisfied with the testimony, that it needed clarification or it related to industries which perhaps might desire to make reply, that the opportunity should be

offered them; that we did not want the public to understand or any industry to understand that we were taking advantage of them in having secret hearings and denying them the opportunity to present to the committee whatever information they desired, to challenge any data or information that was presented to us outside of the open hearings.

Mr. Cox. That is my understanding.

The CHAIRMAN. I think it may be definitely stated that the committee and each member of the committee is desirous of seeing this problem from every possible aspect, and will therefore welcome comment and suggestions and reports from any interested person.¹

Mr. Cox. Mr. Goodrich and I have now agreed upon the letter.² It is a letter dated March 31, 1936, addressed to Lynch Corporation, Anderson, Ind., signed by the Hartford-Empire Co., R. D. Brown, patent lawyer.

The CHAIRMAN. This letter may be admitted. I suggest to the reporter, however, that it be printed in the record in connection with the testimony of Mr. Safford at that point in the record.

(The letter referred to was marked "Exhibit No. 162" and is included in the appendix on p. 801.)

The CHAIRMAN. I am very glad that Mr. Arnold took occasion to express his satisfaction with the attitude of the witnesses who have been called before the committee. I am sure he expressed the opinion of every member of the committee. We feel very grateful to all of the witnesses for the very candid attitude which they have adopted. It is only by this candor that we can hope properly to study the very difficult problem that is before us. And I think it would not be proper to close this phase of the study without expressing, Mr. Arnold, the appreciation which the members of the committee feel for the excellent work that has been done by Mr. Cox and the staff of the Department of Justice. We are all grateful to you.

Mr. GOODRICH. May I thank you, Mr. Chairman, on behalf of the gentlemen of our company, for the unfailing courtesy and kindness of this committee, individually and collectively, throughout these hearings.

The CHAIRMAN. Mr. Goodrich, you have just capped a very pleasant afternoon.

The committee stands in recess at the call of the Chair.

(Whereupon, at 4:10 p. m., an adjournment was taken subject to the call of the chairman.)

¹ Mr. E. G. Ackerman, of the Glass Container Association of America, subsequently submitted, for inclusion in the record, a pamphlet entitled "Survey of Glass Container Industry," which was entered at hearings, February 18, 1939, as "Exhibit No. 303," and is included in the appendix, *infra* p. 803.

² *Supra*, pp. 605, et seq., and 665.

APPENDIX

EXHIBIT No. 90

[Submitted by Mr. Edsel Ford, President, Ford Motor Co.]

Patent threats received by Ford Motor Company, 1926 to date

(Car)

<i>Subject Matter</i>	<i>Case No.</i>	<i>Subject Matter</i>	<i>Case No.</i>
Anchorage.....	45	Brakes.....	333
Automobile Top.....	133	Conductors (Electrical).....	37
Air Preheating.....	86	Connecting Rod.....	42
Apparatus for Drawing Wire.....	167	Curtains.....	52
Axle Shaper.....	172	Cowl Ventilator.....	65
Alloys (Meehanite Metal).....	186	Carburetor (Choke & Needle).....	64
Armature Winding.....	202	Carburetor (Fordson).....	8
Adjustable Seat.....	220	Chassis.....	67
Air Silencer.....	236	Combustion of Fuels.....	113
Automobile Body.....	237	Cafeteria (Weston).....	122
Automobile Top.....	252	Carburetor Choke Control (Lincoln)	138
Air Filter.....	289	Clutch & Drum Lugs.....	139
Ammeter.....	297	Casket Table Arrangement.....	148
Automobile Body.....	304	Curtains.....	150
Air Nozzles.....	305	Carrier (Spare Wheel—Lincoln).....	158
Bumpers.....	5	Chassis and Drive Shaft.....	77
Brake (Oiling of Bands—"T").....	11	Cowl Drip Trough.....	84
Bearing & Clip.....	19	Cowl Ring (Diehl vs. Hicks Interference).....	168
Bumperettes.....	28	Clay Gun.....	188
Battery Box Cover.....	39	Centrifuge (Cleaning Paper).....	200
Balancing Device.....	9	Curtains (Door).....	212
Brakes (Landry Patent).....	85	Cooling System.....	293
Bumper Bar (Front).....	90	Connector.....	303
Bodies K. D.....	100	Combustion Process (Gruetter).....	322
Brake Construction.....	127	Contour Curtain (Weidhaas).....	323
Block (Water Tunnel).....	130	Combustion Chamber Design.....	345
Bakelite.....	92	Coin Machine.....	53
Belt Pulley Clutch Control for Tractors.....	176	Driving Seat.....	18
Bumpers.....	175	Dock (Reinforced Concrete).....	17
Brake, Front Wheel.....	177	Distributor.....	41
Bumper Arm.....	179	Distillation Oven.....	71
Ball Joints.....	195	Drop Pit Jack.....	95
Brake Drums.....	204	Doors.....	105
Baffle Plates.....	206	Dash Drip Trough.....	144
Bumper.....	226	Dust Shields.....	149
Bearings.....	268	Door Latch.....	159
Brakes.....	275	Doval Furnace.....	170
Baffle Plates.....	284	Drive Mechanism (Free Wheeling).....	191
Battery Box Clamps.....	286	Double Entry Bodies.....	201
Beach Spraywater Automatic Machine.....	301	Diaphragm, Flexible.....	227
Bearing (See Dual Thrust Bearing).....	307	Door Lock.....	299
Belt Control (See Tractor Belt Control).....	310	Defroster, Windshield.....	312
Brake Drum Construction.....	316	Exhaust (Lincoln Motor).....	63
Brake Controlling Means.....	344	Electric Furnace Practice.....	109
Brake Mechanism.....	350	Electric Furnaces.....	111
		Electrical Lighting System.....	147

Patent threats received by Ford Motor Company, 1926 to date—Continued

Subject Matter	Case No.	Subject Matter	Case No.
Electrical Switches	82	Intake Air Pre-heating Device	272
Engine (V-8)	196	Ignition System	279
Electric Switch Locks	244	Ignition System	341
Engines (Eight cylinder V-type)	245	Joining (Machines)	154
Engine Hood-Radiator Shell Interconnection	249	Jigs	169
Emergency Brake Construction	257	Knockdown Body	101
Engines (Internal Combustion)	283	Key Case	338
Enamel Finish	313	Lathe (Camshaft & Crankshaft Throws)	27
Fan Pulley & Hub	14	Locks (Nut)	35
Floor Board	20	Lubricating	50
Fan Blade	23	Locks (Door)	7
Fan Shroud	29	Lens	115
Filter (Gasoline)	34	Liner for Wheel Rim	124
Fan (Shroud Attachment)	40	Lock for Ignition Circuits	165
Fender Guards	62	Latches	103
Fog (Electric Generated)	68	Liquid Nickel Polish	208
Frame Brace	118	Louvres (Lincoln)	217
Free Wheeling (Ramsey-Martin Corp.)	126	Lock Washers	233
Free Wheeling (Stokes)	132	Locks	234
Free Wheeling (Mechano)	134	Lubricator	255
Front Cross Brace	78	Lubricant Flow Check	72
Fuel Supply Pipe	87	Laminated Glass	273
Fuel Tank	164	License Plate Frame	340
Fuel Pump	210	Money Changing Machine	49
Furnace	241	Metal Cleaner (Liquid)	187
Fuel Tank	248	Motor Support—Front	213
Fender Design	264	Muffler	223
Fenders, Braces & Supports	290	Means for Lowering Height of Chassis of Motor Vehicles	225
Fuel Pump Shield	306	Mufflers	266
Fender Design	308	Manifolding on Multiple Cylinder Engines	274
Gas Tank	25	Motor Vehicle	292
Gasket (Cowl Ventilator)	24	Mine cars	321
Gauge (Oil)	55	Nut	102
Gear (Speed Change)	91	Nickel Plating	253
Glass (Safety)	106	Oil Retainer for Steering Gear	247
Grinding Valves	161	Packing Ring	48
Glass Turning	192	Pistons (Ribbed)	135
Grinding (Edge)	192	Paint Grinding Machine	198
Gear Grinding	203	Passenger Compartment	207
Grease Gun	199	Pickling Coils	238
Gearing—Starting Mechanism	232	Projectors	278
Gauge	261	Penetrators	314
Governors	270	Power Take-off	354
Glare Shields	276	Piston	22
Gears	298	Rubber (Vulcanizing)	26
Glare Shields	302	Rust Proofing	54
Gear Chucks	330	Ring Gear	59
Gasoline Tanks	336	Radiators	104
Food Hinges	114	Rear View Mirror Bracket	125
Hood Pads	131	Radiator Protector	137
Hood	152	Rubber Compounds	81
Horn (Motor Driven)	174	Rudder Constructions	89
Hobbing Machines	180	Radiator Caps	197
Hobbing Machines	221	Radiator Condenser	205
Hub Cap (Spare Wheel Lock)	263	Reamers—Cutting Blades	211
Hardened Metals	329	Radiator Grill	218
Ingots	66	Radiator Grill—Snap-on Type	219
Index System	56	Radius Rod	231
Ignition Devices	136	Resin	129
Ignition Spark Coils	155	Radio	259
Intake Manifold (Swan)	184	Rear Axle	269
Ignition System	189	Roof Construction	256
Ignition System	215	Radio (Receiving Circuit)	282
Intake Manifold (Down Draft)	224		

Patent threats received by Ford Motor Company, 1926 to date—Continued

<i>Subject Matter</i>	<i>Case No.</i>	<i>Subject Matter</i>	<i>Case No.</i>
Radiator Mounting.....	285	Transmission Bands.....	151
Radiator Units.....	287	Trough.....	156
Roof Construction.....	348	Tire Structure.....	76
Sound Records (Dyer).....	325	Truck Frame.....	94
Spring Lubricating Means.....	339	Tire Rack Brace.....	99
Stabilizer for Crankshaft (Pajet).....	349	Transmission.....	183
Spring Oiling Device.....	353	Tail Lamps.....	194
Starter Switch.....	356	Tuyereage Construction.....	229
Spark Controlling Switches.....	260	Twist Drill Machines.....	262
Seal (Trunk).....	320	Trunk Lock.....	309
Spring Construction (Knee Action).....	317	Triplex Safety Glass.....	311
Starter Clutch.....	334	Transmission Synchronizer.....	342
Steering Column Lock.....	355	Universal Joints.....	216
Spray Gun.....	1	Underslung Attachment for Motor Vehicles.....	240
Steering Wheel.....	3	Universal Joint.....	265
Steering Wheel (Spider Arms).....	4	Uncurling Films—Means of.....	315
Steering Gear.....	10	Vacuum Tubes.....	96
Seamless Pipe Connection.....	47	Ventilating Equipment.....	141
Spark Plugs.....	58	Vaporizer.....	88
Spring Shackles.....	112	Valve Stem.....	235
Steel Ingots (Pouring).....	123	Visor.....	32
Starting Device.....	153	Visor.....	246
Spring.....	157	Vehicle Wheel.....	258
Standrive.....	160	Wheels (Disc).....	60
Steering Range for Automobiles.....	74	Wheels (Wire).....	15
Starter Mechanism.....	171	Wheels (Wire).....	70
Spring Shackle.....	178	Wheels (Wire).....	33
Sun Glare Visors.....	182	Windshield Wing Clamp.....	38
Steering Gear—Boats.....	185	Wind Guards.....	36
Spray Booth Application.....	193	Wind Guards.....	43
Steering Mechanism.....	209	Welding (Arc).....	46
Shaft Coupling—Steering Gear.....	230	Wheel (Fordson).....	51
Seepage—Intercepting Cowl.....	243	Windguards.....	57
Strainer for Gasoline Tank.....	44	Wheel Structure.....	97
Steering Wheels.....	250	Welt (Hidem).....	121
Starting Device.....	251	Windshield Wiper.....	140
Steering Gear.....	254	Windshield Construction.....	142
Steel—Chrome Nickel Molybdenum.....	267	Water Pumps.....	143
Shock Absorbers.....	271	Welding Equipment.....	146
Shock Absorbers.....	288	Windshield Wing Clamp.....	75
Seat Arrangement.....	291	Water-proofing Paper & Cardboard.....	163
Sash Regulator.....	294	Water Pump.....	228
Stop Light & Tail Lamp.....	295	Water Pump.....	242
Soy Bean Oil.....	296	Wheels.....	73
Stabilizers.....	300	Window Regulator.....	277
Ship Construction.....	318	Wrist Pin Connection.....	281
Stabilizer.....	319	Windshield Defroster (Grant).....	324
Shackle Bolt.....	352	Wheel Alignment Machine (Duby & Creagmile).....	327
Truck Chassis.....	6	Water Pump.....	351
Transmission (Lincoln).....	21	Wheel Alignment Machine.....	326
Tire Carrier.....	31	Window (Rear).....	337
Top Bows.....	61	Windshield.....	343
Transmission (Fordson Clutch).....	69		
Tube Connection & Nut.....	110		
Thrust Bearing Sleeve (Propeller Shaft).....	119	Total Threats received (Car and Aeroplane).....	346

EXHIBIT No. 91

ARTICLES OF INCORPORATION, CONSTITUTION, AND BY-LAWS

Automobile Manufacturers Association, Inc., New York. Printed February 1938

AUTOMOBILE MANUFACTURERS ASSOCIATION, INC.

A corporation duly organized under the MEMBERSHIP LAWS OF THE STATE OF NEW YORK, Chapter 35, of the CONSOLIDATED LAWS OF NEW YORK, 1909, ARTICLE XII, Section 180, entitled "BOARDS OF TRADE," CONSOLIDATED LAWS OF NEW YORK, 1909, Volume III, page 3444.

CERTIFICATE OF INCORPORATION OF *AUTOMOBILE CHAMBER OF COMMERCE, INC.

We, the undersigned, all being of full age and citizens of the United States, and at least one of us a resident of the State of New York, desiring to form a corporation commonly called a board of trade, pursuant to the provisions of the Membership Corporation Laws of the State of New York, do hereby make, sign, acknowledge, and file this certificate for that purpose as follows:

FIRST.—The name of the proposed corporation is *"AUTOMOBILE CHAMBER OF COMMERCE, Inc."

SECOND.—The particular objects for which the corporation is to be created are:

To foster the interest of those engaged in the trade or business of manufacturing automobiles and all other self-propelling vehicles;

To reform abuses relative thereto;

To secure freedom of its members from unjust or unlawful exactions;

To diffuse accurate and reliable information as to the standing of merchants and others dealing with members, as to all inventions, patents, processes, or devices designed or intended for use in, upon, or in connection with such vehicles and the manufacture thereof, as to the state of the art relative thereto, and as to the condition and development of the trade in which the members are engaged, in the United States and foreign countries;

To procure uniformity and certainty in the customs and usages of such trade;

To promote the construction of better highways;

To advocate the enactment of just and equitable laws affecting members;

To settle differences between members;

To promote a more enlarged and friendly intercourse among business men engaged in such trade or dealing with persons engaged therein;

To acquire by grant, gift, purchase, devise, or bequest, to hold and to dispose of such property as the purposes of the corporation shall require, subject to such limitations as may be prescribed by law, including inventions, letters patent and processes, or rights thereunder, for the benefit of its members and not for pecuniary profit.

THIRD.—The city in which its principal office is to be situated is Borough of Manhattan, City and County of New York, N. Y.

FOURTH.—The names and places of residence of the persons to be its directors, until its first annual meeting are:

Charles Clifton.....	Buffalo, N. Y.
Charles C. Hanch.....	Indianapolis, Indiana
Hugh Chalmers.....	Detroit Michigan
Sidney D. Waldon.....	Detroit, Michigan
Samuel T. Davis, Jr.....	Bridgeport, Connecticut
W. C. Leland.....	Detroit, Michigan
Windsor T. White.....	Cleveland, Ohio
Wm. E. Metzger.....	Detroit, Michigan
H. O. Smith.....	Indianapolis, Indiana
Albert L. Pope.....	Hartford, Connecticut
L. H. Kittredge.....	Cleveland, Ohio
R. D. Chapin.....	Detroit, Michigan
G. W. Bennett.....	Toledo, Ohio
H. H. Rice.....	Indianapolis, Indiana

* Footnote on p. 673.

*FIFTH.—The number of its directors is to be fourteen.

SIXTH.—The first annual meeting of the corporation shall be held on June 4, 1914. Thereafter the time for holding its annual meetings shall be on the first Thursday after the first Wednesday of June in each year.

*SEVENTH.—The duration of this corporation shall be twenty-five years.

CONSTITUTION OF AUTOMOBILE MANUFACTURERS ASSOCIATION, INC.

ARTICLE I

Name of the Corporation

Section 1. The name of this corporation shall be AUTOMOBILE MANUFACTURERS ASSOCIATION, INC.

Principal Office

Section 2. Its principal office shall be situated in the Borough of Manhattan, City and County of New York and State of New York.

ARTICLE II

Objects of the Corporation

Section 1. The purposes and objects of this corporation are:

To foster the interests of those engaged in the trade or business of manufacturing automobiles and all other self-propelling vehicles;

To reform abuses relative thereto;

To secure freedom of its members from unjust or unlawful exactions;

To diffuse accurate and reliable information as to the standing of merchants and others dealing with members, as to all inventions, patents, processes, or devices designed or intended for use in, upon, or in connection with such vehicles and the manufacture thereof, as to the state of the art relative thereto, and as to the condition and development of the trade in which the members are engaged, in the United States and foreign countries;

To procure uniformity and certainty in the customs and usages of such trade;

To promote the construction of better highways;

To advocate the enactment of just and equitable laws affecting members;

To settle differences between members;

To promote a more enlarged and friendly intercourse, among business men engaged in such trade or dealing with persons engaged therein;

To acquire by grant, gift, purchase, devise, or bequest, to hold and to dispose of such property as the purposes of the corporation shall require, subject to such limitations as may be prescribed by law, including inventions, letters patent, and processes, or rights thereunder, for the benefit of its members and not for pecuniary profit.

ARTICLE III

Membership

Section 1. Members of the Corporation shall consist of "Manufacturing Members" and "Representative Members." Any individual, co-partnership firm, or corporation actually engaged in the manufacture and sale of self-propelled vehicles shall be eligible for membership as a "Manufacturing Member." Each co-partnership firm and corporation "Manufacturing Member" shall be entitled to designate, in form and manner prescribed by the Directors, one Member of such co-partnership firm, or one Director, Officer, or Stockholder of such corporation, as the case may be, as a "Representative Member," and upon such designation the person so designated shall be enrolled as a "Representative Member" (in such case the "Manufacturing Membership" shall be known as "simple"); provided, however, that in case such "Manufacturing Member" shall produce at separate plants, respectively, different "makes," so-called, of self-propelled vehicles to be sold under distinctive generic trade names, then such "Manufacturing Member" shall be entitled to designate as aforesaid one "Representative

*The original Certificate of Incorporation was approved by the Supreme Court on the 17th day of March, 1913, and filed in the office of the Secretary of State, on the 18th day of March 1913, and in the office of the Clerk of New York County, on the 19th day of March 1913.

Thereafter Certificates of Changes were filed, changing the number of directors to fifteen, and later to twelve, and the name of the corporation to "National Automobile Chamber of Commerce, Inc.", and later to "Automobile Manufacturers Association, Inc.", and extending the existence of the Corporation a further twenty-five years to the 18th day of March 1963.

Member" for each such distinctive "make" of self-propelled vehicle manufactured by it (in such case the "Manufacturing Membership" shall be known as "multiple").

Type of Membership

Section 2. (1) In case of an application for membership by an individual, co-partnership firm, or corporation, the Directors of the Corporation shall determine whether the applicant shall take "simple" or "multiple" membership.

(2) Where the status of a "Manufacturing Member" shall change with respect to the production of different "makes" of self-propelled vehicles to be sold under distinctive generic trade names and produced at separate plants, the Directors of the Corporation shall have the power to determine whether such "Manufacturing Member" shall continue to hold membership of the existing type or to require said "Manufacturing Member" to change from the "simple" to the "multiple" or from the "multiple" to the "simple" as the case may be.

Termination of Representative Membership

Section 3. The membership of a "Representative Member" shall cease:

(1) Upon the termination of the membership of the "Manufacturing Member" so designating him;

(2) Upon the revocation of such designation by such "Manufacturing Member";

(3) Upon a change in membership of the "Manufacturing Member" from "multiple" to "simple" or vice-versa.

Voting Power

Section 4. At any meeting of the members of the corporation each "Manufacturing Member", whether an individual, co-partnership firm or corporation shall be entitled to cast on each and every question as many votes as it has "Representative Members" which votes may be cast by the designated "Representative Members" representing said "Manufacturing Member" if said "Representative Members" be present, and in the absence of any designated member, his vote may be cast by any duly authorized agent or proxy or other "Representative Member" of said "Manufacturing Member." Cumulative voting shall not be allowed.

Quorum

Section 5. At all meetings of the members of the corporation, one-third of the members, whether "Manufacturing" or "Representative Members" present in person or by proxy, shall constitute a quorum for the transaction of business, but a less number shall have power to adjourn to a future date, which date shall be stated.

ARTICLE IV

Directors

Section 1. The general affairs of this corporation shall be managed by twelve Directors, who shall be members of the corporation, of whom at least one shall be a resident of the State of New York. The first Board of Directors shall be classified into three classes, whose tenure of office shall be respectively one, two and three years. Hereafter at each annual election, four members shall be elected by ballot for a term of three years to take the place of those four members whose terms of office expire on the date of such annual election. All members of the Board of Directors shall hold office until their successors are elected.

Section 2. Included in the list of Directors as herein provided shall be at least one from each active Division of the industry, such divisions to be determined from time to time by the Directors.

Section 3. Upon any Director ceasing to be a Member of the corporation, he shall thereby cease to be a Director, and the vacancy thus caused shall be filled by the Directors until the next annual meeting, when a Director for the unexpired term shall be elected by the members.

Section 4. Said Directors shall organize by the election of a Chairman, and Vice-Chairman, who shall be of their own number, and a Secretary and Treasurer, who need not be Directors. The officers so chosen shall respectively be, President, First Vice-President, Secretary, and Treasurer of the corporation.

Section 5. The Board of Directors shall annually elect from its membership a Second Vice-President from each active Division of the industry, and one or more, but not over three, Third Vice-Presidents, who need not be elected from

the Board of Directors, nor from an active Division of the industry. A majority of the Directors shall constitute a quorum for the transaction of business.

Section 6. The Directors shall make a report at each annual meeting of the members in accordance with Section 11 of the Membership Corporation Laws of the State of New York.

Contracts

Section 7. No Director or other officer of this corporation shall be interested directly or indirectly in any contract relating to the operations conducted by the corporation, nor in any contract for furnishing supplies thereto, unless expressly authorized so to do by the concurring vote of all the Directors.

Contracts Involving Over \$10,000

Section 8. No contract for any purpose involving the expenditure of a sum of money in excess of ten thousand dollars in any one matter, shall be made or entered into by the Officers or Directors of the corporation, except upon the approval by a vote of at least two-thirds of the members present and voting at a regular or special meeting duly called and held as provided in the By-Laws, but the corporation shall have no power or authority to make any member a party to a contract and the approval by a member of any contract, expressed by the members' voting to approve the same, shall be merely an approval of proposed action by the corporation and shall not constitute a consent or grant of authority to the corporation to make a member a party to a contract or to give power to the corporation to represent or act as agent for the approving member in respect to such contract in any way whatever.

ARTICLE V

Dues of "Manufacturing Members"

Section 1. The Directors shall fix and determine the dues to be paid by the "Manufacturing Members" during the current fiscal year, which dues shall be based on, but not necessarily in proportion to the sales of the "Manufacturing Members," respectively of self-propelled vehicles sold or otherwise disposed of during the then fiscal year; but in no case shall such dues be fixed or determined at a greater amount than one-tenth of one per cent. of such sales, which sales shall be the list price of the vehicles sold, less the commission or discount allowed to dealers or to any selling branch controlled by the "Manufacturing Members." The dues so fixed and determined shall be payable quarterly. Subject to the limitations herein provided, the Directors may, subsequently to fixing the amount of said dues during the current fiscal year, increase or diminish the amount thereof. The dues of any "Manufacturing Member" for any fiscal year beginning July first, shall be not less than five hundred (\$500) dollars net cash, but shall automatically cease for the balance of that year when the member shall have paid into the treasury as dues, the sum of forty thousand (\$40,000) dollars net cash during the year; provided however, in the case of "Manufacturing Members" holding "multiple" memberships and producing different "makes" so-called, of self-propelled vehicles to be sold under distinctive generic trade names, the minimum sum of \$500, and the maximum sum of \$40,000 shall apply separately to each such distinctive "make" of self-propelled vehicle.

Reports by Members

Section 2. Each "Manufacturing Member" shall render to the corporation within the first fifteen days of January, April, July and October of each year, written reports under oath setting forth the number and kinds of self-propelled vehicles made and sold or otherwise disposed of, by such member, during the preceding three calendar months, and the aggregate net amount charged therefor, not including, however, any sales of parts or any repairs, and shall within fifteen days thereafter pay to the corporation on account of annual dues, the just and true percentage thereof, not exceeding one-tenth of one percent, which shall have been so fixed and determined by the Directors, except as otherwise provided in Section 1 of Article V; provided, however, that "Manufacturing Members" producing more than one "make" so-called of self-propelled vehicles to be sold under distinctive generic trade names shall render separate reports for each such "make." These reports shall cover all self-propelled vehicles primarily intended to operate upon the road, and shall not apply to self-propelled machinery primarily intended for use on the farm, farm tractors, self-propelled boats or other water-

borne vessels, or self propelled aircraft. A discount of ten percent, shall be allowed to each "Manufacturing Member" if payment accompanies report within the time above specified. Each "Manufacturing Member" shall keep true and accurate records of the number and kinds of such vehicles made and sold or otherwise disposed of by it and accurate books of account of all its sales of such vehicles, and shall permit a reasonable inspection thereof by the duly authorized representative or representatives of the corporation for the purpose of verifying any report so made by such member or obtaining the information required to be reported in case a member shall neglect or refuse to make such a report, and such right of inspection for the purposes named, shall survive the termination of membership of such "Manufacturing Member."

ARTICLE VI

Defense of Suits

Section 1. Upon advice of counsel of the corporation that it would promote the purposes and objects of the corporation so to do, and upon the recommendation of the Directors, approved by a vote of two-thirds of the members of the corporation present and voting at a regular or special meeting of the corporation called and held as provided in the By-Laws, the corporation shall undertake the defense of any suit brought by a member or a non-member against any "Manufacturing Member" thereof, or other party, based upon any patent claim or claims. The Directors shall thereupon make provision for defending such suit upon such terms and conditions relative to the control and management of the defense of said suit as the Directors shall determine, and the corporation shall pay all disbursements and expenses, including fees of counsel, which shall be incurred in and about the defense of such suit except so far as the defendants may otherwise agree but such payment by the corporation shall not include any sum awarded to the complainant by the decree of the Court as either damages or costs.

In the defense of any suit, the corporation shall not have the power to act as agent for any member other than a member named as defendant in the suit and formally of record; and it shall obtain in writing from the member or other party sued authority to control the defense of the suit. No member not named as defendant in the suit and formally of record shall have any authority or power to control or intermeddle in any way with the defense of the suit; and no member not so named and formally of record as a party to the suit shall be liable for any part of the expenses of such suit, all of which, so far as payable by the corporation, shall be paid by the corporation out of its general funds. The approval by a member of a recommendation of the directors of the corporation in respect to the defense of a suit, expressed by the member's voting to approve the same, shall be merely an approval of proposed action by the corporation and shall not be consent or grant of authority to the corporation to represent or act for the approving member as to the patent or patents in suit or in any way whatever.

Suits Now Pending

Section 2. The benefits of this corporation as herein contemplated may be granted to its members in respect to patent suits and claims now pending against them as well as those which may hereafter be presented or prosecuted, to the extent only of any future proceedings to be taken.

ARTICLE VII

Licenses and Shop Rights

Section 1. Upon the acquisition of any patent or transferable rights thereunder, the corporation, so far as it shall have the lawful right to do so, shall, upon a resolution being adopted by an affirmative vote of not less than a majority of the Directors and duly approved by the affirmative vote of two-thirds of the members present, and voting at a regular or special meeting called and held as provided in the By-Laws, grant to each then "Manufacturing Member" of the corporation in good standing desiring it, a license or shop right thereunder, upon such terms and conditions as shall be determined by the affirmative vote of two-thirds of the members present and voting at such meeting, but the terms and conditions shall be alike to each then "Manufacturing Member"; and grant to each subsequent "Manufacturing Member" of the corporation in good standing desiring it, a license or shop right thereunder, upon such terms and conditions as shall be determined by the affirmative vote of not less than a majority of the Directors and duly

approved by the affirmative vote of two-thirds of the members present and voting at such regular or special meeting.

ARTICLE VIII

Dissolution

Section 1. Upon dissolution of this corporation the "Representative Members" shall not be entitled to participate in the distribution of the funds or assets of this corporation. Each then "Manufacturing Member" in good standing shall be entitled to share in the distribution of the funds and assets of the corporation in proportion to the aggregate amount of money paid by him to the corporation from time to time as dues or assessments.

ARTICLE IX

Obligations of Members

Section 1. The Constitution and By-Laws and any amendments thereof hereafter made shall be deemed a contract with the corporation and among the members, for the benefit of each and all, and shall be observed and adhered to by each member, and each member of this corporation by virtue of his membership covenants and agrees with the corporation and with each and every member thereof that he will observe, adhere to and be bound by the same.

ARTICLE X

Amendments

Section 1. This Constitution or any article thereof may be altered, amended or repealed at any regular or special meeting of the members of the corporation by the affirmative vote of three-fourths of the members of the corporation present and voting, provided that written notice of the alteration, amendment or repeal signed by not less than eight members of the corporation shall have been served upon the corporation at least forty days prior to the meeting at which the alteration, amendment or repeal is to be considered. Notice of any proposed amendment shall be given the members at least fifteen days prior to the meeting at which the amendment is to be considered.

BY-LAWS OF AUTOMOBILE MANUFACTURERS ASSOCIATION, INC.

ARTICLE I

Annual Meeting

Section 1. The annual meetings of the members of the corporation and the election of Directors shall be held at the office of the corporation in the City of New York in accordance with the Articles of Incorporation. Notices of the time and place of the meetings, signed by the Secretary, shall be mailed to each member of the corporation at least ten days before such annual meetings, and such other notice shall be given as may be required by law.

Special Meetings

Section 2. Special meetings of the members shall be convened by order of the Directors or of the President at the corporation's office in the City of New York or elsewhere upon notice signed by the Secretary and mailed to each member of the corporation at least ten days before such meeting. It shall be the duty of the Directors or of the President to call a special meeting of members whenever requested in writing by one-tenth of the manufacturing members so to do.

ARTICLE II

Admission to Charter Membership

Section 1. The Directors of this corporation, at any regular or special meeting held within ninety days after the incorporation of this corporation shall, upon application, elect to manufacturing membership any member in good standing of the Automobile Board of Trade or National Association of Automobile Manufacturers.

Applications for Membership

Section 2. Applications for Manufacturing Membership in this corporation by others than those who may be elected in pursuance of the foregoing section of this article must be made in form to be prescribed by the Directors, addressed to the corporation, signed by the applicant and endorsed with the approval of at least two members in good standing.

Election to Membership

Section 3. Except as provided in Section 1 of this Article, no individual, co-partnership firm, or corporation shall be elected a member of this corporation except by the affirmative vote of not less than a majority of the Directors. In case an applicant for membership shall fail of election by the Directors, the corporation may elect such applicant by a two-thirds vote of the members present and voting at any meeting.

Conditions of Membership

Section 4. The Corporation may, by contract or agreement duly entered into with any one or more "Manufacturing Members" of the Corporation, bind itself to impose upon future applicants for membership any conditions not in themselves unlawful; and while such contract or agreement is in force, no applicant shall be eligible for membership except upon fulfilling the conditions so imposed, provided always that such contract or agreement is authorized and approved by the affirmative vote of not less than a majority of the Directors.

Qualification of Members

Section 5. No individual, co-partnership, firm, or corporation elected a "Manufacturing Member" shall be deemed to have become a member of the corporation unless and until he or it shall have qualified by paying to the Treasurer, within fifteen days after notice of his or its election, the sum of One Thousand Dollars (\$1,000) to apply upon his or its dues.

Delinquency

Section 6. Any "Manufacturing Member" whose dues or any part thereof are in arrears shall be deemed not in good standing. Any "Manufacturing Member" who shall continue not in good standing for a period of twenty days after due notice thereof that he or it is not in good standing and that he or it is in danger of the forfeiture provided in this section, shall be deemed to have forfeited his or its membership, and such member can only be reinstated by the affirmative vote of not less than a majority of the Board of Directors after full settlement of any delinquent dues. In case a delinquent shall fail of reinstatement by the Board of Directors, the corporation may reinstate such delinquent by a two-thirds vote of the members present and voting at any meeting. The notice to be served on a member not in good standing shall quote this section and shall be delivered to the member personally or served by mail in a postpaid envelope addressed to him or it at his or its last known place of business.

Expulsion

Section 7. Any "Representative" or "Manufacturing Member" who shall do any act in the judgment of the Directors amounting to a wilful violation or breach of any of the terms of the Constitution or By-Laws, may be expelled from membership by a two-thirds affirmative vote of all the Board of Directors, provided, however:

(1) That notice in writing of the proposed expulsion shall have been mailed to each member of the Board of Directors at his last known address, ten days before such action shall be taken;

(2) That formal charges drafted by a committee appointed for that purpose stating the name, address, and description of the business of the accused member, the charges in full detail and the grounds for the same shall have been presented to the corporation at least thirty days before such action be taken;

(3) That there shall have been posted by registered letter to the member under charges at his address appearing on the books of the corporation a statement of the charges at least fifteen days before final action thereon be taken; this state-

ment shall be accompanied by a notice of the time and place when and where the Board of Directors is to take action in the premises;

(4) That the said member shall have been given an opportunity to present his or its defense at the time and place mentioned in such notice.

Votes upon questions of expulsion shall be by secret ballot.

If the member on trial is a member of the Board of Directors he shall have no right to be present and vote when ballots are passed upon the question of his expulsion, and in such case all questions of quorum, ratio of votes cast, etc., shall be determined as though the Board of Directors consisted of one less than the stated number.

By application for or acceptance of membership in the corporation every "Manufacturing Member" shall be deemed to have waived and does thereby waive for himself or itself, as the case may be, in case of his or its expulsion from the corporation as hereinbefore provided, all further rights and privileges of membership and all claims of every nature and description to any fees, dues or charges paid to the corporation and to any participation in its assets or benefits, and to any and all claims for damages for or because of such expulsion.

Termination of Membership

Section 8. In case any member shall cease to have the qualifications making him or it eligible for membership in this corporation as provided in the Constitution and By-Laws, such person shall thereby cease to be a member of the corporation, subject, however, to reinstatement upon restoration of eligibility and payment of all arrears in dues.

Effect of Termination of Membership

Section 9. The right of a member to vote, and all the right, title and interest of a member in or to the corporation or its property shall cease upon the termination of his membership therein unless otherwise provided by law or by the Constitution or By-Laws of the corporation, or by a vote of the Board of Directors or of the members.

ARTICLE III

Powers of Directors

Section 1. The Directors may appoint such officers, agents, attorneys, and counsel as they may judge proper, prescribe their compensation and fix the amounts of such bonds as they may require. They may fill vacancies in their own body. In the absence of the President and First Vice-President they may appoint a Chairman pro tem. During a prolonged absence or inability of the President and First Vice-President they may appoint substitutes pro tem. On the death or resignation of any officer they shall fill the vacancy. A majority of the Directors shall be required to constitute a quorum for the transaction of business, but less than a quorum may adjourn from time to time.

Meetings of Directors

Section 2. The regular meetings of the Board of Directors for the transaction of business shall be held at the office of the corporation or elsewhere, as designated by the Board of Directors, on the first Wednesday of every month, unless such day is a holiday, in which case the meeting shall occur on the same day of the following week, or unless a meeting of Representative Members is scheduled on that day, in which event the Directors shall meet the day before. The President, and in his absence the First Vice-President, shall preside at all meetings of the Directors and in their absence a Chairman pro tem. shall be appointed.

Section 3. Special meetings shall be held at such times and places as the President may direct or upon the written request of any two Directors.

Rules

Section 4. The Directors shall make such rules or regulations for the calling of special meetings of their body as they deem proper.

Absence from Meetings

Section 5. Any Director absenting himself from three consecutive meetings of the Directors, unless his absence is excused by the board, shall be deemed to have resigned his directorship, and the vacancy thus created shall be filled by the Directors.

Divisions

Section 6. Any group of "Manufacturing Members" producing a distinct type of vehicle may, with the consent of the Directors, form a Division of the membership, for the purpose of fostering the particular interests of such Division.

Committees

Section 7. The President, subject to the approval of the Directors, may appoint such special committees as he deems necessary to protect and further the interests, purposes, and objects of the corporation and its members. The members of such committees need not be Directors.

Order of Business

Section 8. The Directors may by resolution prescribe the order of business at their meetings.

ARTICLE IV

President

Section 1. The President shall preside at all meetings of the Members and Directors. He shall have power to call meetings of the Directors or Committees from time to time, when he shall think proper, and it shall be his duty to call such meetings, when requested in writing to do so by any two Directors. He shall have the general care, supervision, and direction of the affairs of the corporation under the direction of the Directors and shall have such powers and perform such duties as may from time to time be conferred upon him or be prescribed by such Directors. He shall discharge the duties of the Treasurer in case of his absence or inability or during a vacancy in the office.

First Vice President

Section 2. The First Vice President shall discharge the duties of the President in case of his absence or during a vacancy in the office.

Second Vice Presidents

Section 3. The Second Vice Presidents shall be Chairmen of their respective Divisions and shall discharge such duties as may be prescribed by the Directors.

Third Vice Presidents

Section 4. The Third Vice Presidents shall discharge such duties as may be prescribed by the Board of Directors.

ARTICLE V

Treasurer

Section 1. It shall be the duty of the Treasurer to receive all the moneys, checks, and drafts paid in on behalf of this corporation and immediately endorse the same for deposit, and enter the same in the books of the corporation, and immediately deposit the same in a bank or banks designated by the Directors to the credit of the corporation. He shall render such accounts and present such statements to the Directors as may be required by them, and his books and accounts shall always be open to the inspection of any Director. Disbursements shall be made by him only under resolutions of the Directors. He shall be required to give bond for the faithful performance of his duties, and the expense thereof shall be paid by the corporation. He shall hold his office until his successor shall have been appointed and shall have qualified. He shall make a report to the members of his receipts and disbursements at each regular meeting of the members. His accounts shall be audited from time to time, and at least annually, by an auditor or auditors appointed by the Board of Directors. The President shall discharge the duties of the Treasurer in case of his absence or inability or during a vacancy in the office.

Checks

Section 2. All checks, drafts, and orders for the payment of money shall be signed by the Treasurer or the President or the First Vice President or any person who shall be thereunto authorized, from time to time, by general or special resolution of the Board of Directors.

Notes

Section 3. All notes negotiable or non-negotiable, shall be signed by the President, or the First Vice President, and the Treasurer or such other person as the Board of Directors shall from time to time authorize by general or special resolution.

ARTICLE VI

Secretary

Section 1. It shall be the duty of the Secretary to give notice of all meetings of the members of the corporation and of all meetings of the Board of Directors and when required so to do by the President or by resolutions of the Board of Directors to attend such meetings when practicable, keep true records of the proceedings thereof, attest such records after every meeting by his signature, and safely keep all documents and papers which shall come into his possession. He shall also perform such other and further duties as shall be required by the President and Board of Directors.

The seal on all instruments requiring a seal shall be affixed and attested by the Secretary.

ARTICLE VII

Seal

Section 1. The seal of the corporation shall be a circle containing the name of the corporation around the inner edge thereof, and the word "SEAL" and the figures "1913" in the center thereof, and the words "NEW YORK" on the bottom thereof.

ARTICLE VIII

Order of business

Section 1. The order of business of all regular meetings of the members of the corporation shall be as follows:

1. Roll call.
2. Action upon Minutes of previous meeting.
3. Reports of officers.
4. Reports.
5. Unfinished business.
6. Election of new members.
7. New business.

ARTICLE IX

Amendments

Section 1. These By-Laws may be altered, amended, or repealed by a two-thirds vote of the members of this corporation, present at a regular or special meeting, provided that written notice of the alteration, amendment, or repeal, signed by not less than eight members of the corporation, shall have been served upon the corporation at least forty days prior to the meeting at which the alteration, amendment, or repeal is to be considered. Notice of any proposed alteration, amendment, or repeal shall be given to the members at least fifteen days prior to the meeting at which the alteration, amendment, or repeal is to be considered.

EXHIBIT No. 92

[Source: Automobile Manufacturers Association magazine]

MEMBERS OF THE AUTOMOBILE MANUFACTURERS ASSOCIATION
CORRECTED TO NOVEMBER 1938

NEW YORK

366 Madison Avenue at 46th Street

General Motors Building
DETROITTransportation Building
WASHINGTON

PASSENGER CAR MANUFACTURERS

Trade Name	Member or Manufacturer	Address
Buick.....	Buick Motor Division*	Flint, Mich.
Cadillac.....	Cadillac Motor Car Division*	Detroit, Mich.
Chevrolet.....	Chevrolet Motor Division*	Detroit, Mich.
Chrysler.....	Chrysler Sales Division†	Detroit, Mich.
De Soto.....	De Soto Division†	Detroit, Mich.
Dodge.....	Dodge Division†	Detroit, Mich.
Graham.....	Graham-Paige Motors Corporation	Detroit, Mich.
Hudson.....	Hudson Motor Car Company	Detroit, Mich.
Hupmobile.....	Hupp Motor Car Corporation	Detroit, Mich.
LaSalle.....	Cadillac Motor Car Division*	Detroit, Mich.
Nash.....	Nash-Kelvinator Corporation	Detroit, Mich.
Oldsmobile.....	Olds Motor Works Division*	Lansing, Mich.
Packard.....	Packard Motor Car Company	Detroit, Mich.
Plymouth.....	Plymouth Division†	Detroit, Mich.
Pontiac.....	Pontiac Motor Division*	Pontiac, Mich.
Studebaker.....	The Studebaker Corporation	South Bend, Ind.
Willys.....	Willys-Overland Motors, Inc.	Toledo, Ohio.
Hudson Terraplane.....	Hudson Motor Car Co.	Detroit.

TAXICAB MANUFACTURERS

Checker.....	Checker Cab Mfg. Corporation	Kalamazoo, Mich.
G. M. C.....	Yellow Truck and Coach Manufacturing Company	Pontiac, Mich.

AMBULANCE AND FUNERAL VEHICLE MANUFACTURERS

Cadillac.....	Cadillac Motor Car Division*	Detroit, Mich.
Packard.....	Packard Motor Car Company	Detroit, Mich.
Studebaker.....	The Studebaker Corporation	South Bend, Ind.

MOTOR FIRE APPARATUS MANUFACTURERS

Corbitt.....	The Corbitt Company	Henderson, N. C.
Mack.....	Mack Brothers Motor Car Company	Long Island City, N. Y.
Walter.....	Walter Motor Truck Company	Ridgewood, N. Y.
White.....	The White Motor Company	Cleveland, Ohio.

MOTOR TRUCK MANUFACTURERS INCLUDING LIGHT COMMERCIAL VEHICLE AND
STATION-WAGON MANUFACTURERS

Autocar.....	The Autocar Company	Ardmore, Pa.
Chevrolet.....	Chevrolet Motor Division, General Motors Corp.	Detroit, Mich.
Corbitt.....	The Corbitt Company	Henderson, N. C.
Diamond T.....	Diamond T Motor Car Company	Chicago, Ill.
Dodge.....	Dodge Division†	Detroit, Mich.
Federal.....	Federal Motor Truck Company	Detroit, Mich.
G. M. C.....	Yellow Truck and Coach Manufacturing Company	Pontiac, Mich.
Hudson Terraplane.....	Hudson Motor Car Company	Detroit, Mich.
Indiana.....	The White Motor Company	Cleveland, Ohio.
International.....	International Harvester Company	Chicago, Ill.
LaFrance-Republic.....	Sterling Motor Truck Company	Milwaukee, Wis.
Mack.....	Mack Brothers Motor Car Company	Long Island City, N. Y.
Plymouth.....	Plymouth Division†	Detroit, Mich.
Reo.....	Reo Motor Car Company	Lansing, Mich.
Sterling.....	Sterling Motor Truck Company	Milwaukee, Wis.
Stewart.....	Stewart Motor Corporation	Buffalo, N. Y.
Studebaker.....	The Studebaker Corporation	South Bend, Ind.
Walter.....	Walter Motor Truck Company	Ridgewood, N. Y.
White.....	The White Motor Company	Cleveland, Ohio.
Willys.....	Willys-Overland Motors, Inc.	Toledo, Ohio.

† Chrysler Corporation.

* General Motors Corporation.

TRUCK TRAILER MANUFACTURERS

Trade Name	Member or Manufacturer	Address
Corbitt.....	The Corbitt Company.....	Henderson, N. C.
G. M. C.....	Yellow Truck and Coach Manufacturing Company.....	Pontiac, Mich.
Mack.....	Mack Brothers Motor Car Company.....	Long Island City, N. Y.
Reo.....	Reo Motor Car Company.....	Lansing, Mich.

MOTOR BUS MANUFACTURERS

Diamond T.....	Diamond T Motor Co.....	Chicago, Ill.
Federal.....	Federal Motor Truck Company.....	Detroit, Mich.
G. M. C.....	Yellow Truck and Coach Manufacturing Company.....	Pontiac, Mich.
Indiana.....	The White Motor Company.....	Cleveland, Ohio.
I. H. C.....	International Harvester Company.....	Chicago, Ill.
Mack.....	Mack Brothers Motor Car Company.....	Long Island City, N. Y.
Reo.....	Reo Motor Car Company.....	Lansing, Mich.
Stewart.....	Stewart Motor Corporation.....	Buffalo, N. Y.
Studebaker.....	The Studebaker Corporation.....	South Bend, Ind.
White.....	The White Motor Company.....	Cleveland, Ohio.

OFFICERS

<i>President</i>	ALVAN MACAULEY, Packard Motor Car Company.
<i>First Vice President</i>	ALFRED P. SLOAN, Jr., General Motors Corporation.
<i>Vice-President</i>	CHARLES W. NASH, Nash-Kelvinator Corporation.
Passenger Car Division	
<i>Vice-President</i>	ROBT. F. BLACK, White Motor Co.
Commercial Car Division	
<i>Vice-President</i>	ALFRED REEVES, New York.
<i>Vice-President</i>	PYKE JOHNSON, Washington, D. C.
<i>Secretary</i>	BYRON C. FOY, DeSoto Motor Corporation.
<i>Treasurer</i>	F. J. HAYNES, Detroit, Michigan.

BOARD OF DIRECTORS

A. EDWARD BARIT.....	Hudson Motor Car Company.
R. F. BLACK.....	The White Motor Company.
WALTER P. CHRYSLER.....	Chrysler Corporation.
E. C. FINK.....	Mack Bros. Motor Car Company.
BYRON C. FOY.....	DeSoto Motor Corporation.
ROBERT C. GRAHAM.....	Graham-Paige Motors Corporation.
PAUL G. HOFFMAN.....	The Studebaker Corporation.
WILLIAM S. KNUDSEN.....	General Motors Corporation.
ALVAN MACAULEY.....	Packard Motor Car Company.
WILLIAM F. McAFEE.....	International Harvester Company.
CHARLES W. NASH.....	Nash-Kelvinator Corporation.
ALFRED P. SLOAN, Jr.....	General Motors Corporation.
<i>Vice-President and General Manager</i>	ALFRED REEVES.
<i>Assistant General Manager</i>	JAMES S. MARVIN..

"EXHIBIT No. 93", introduced on p. 287, is on file with the Committee.

"EXHIBIT No. 94", introduced on p. 287, is on file with the Committee.

"EXHIBIT No. 95", introduced on p. 296, is on file with the Committee.

"EXHIBIT No. 96", introduced on p. 296, is on file with the Committee.

"EXHIBIT No. 97", introduced on p. 296, is on file with the Committee.

"EXHIBIT No. 98", introduced on p. 296, is on file with the Committee.

EXHIBIT No. 99

Percent Automotive to Total Patents Issued

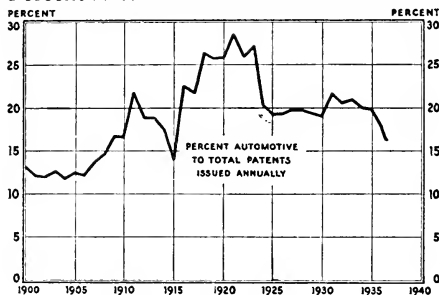

Number of patents issued declining in recent years

[Source: Automobile Facts magazine]

[In general it takes 2 to 3 years for an application to become a patent]

	Total patents issued ¹	Automotive total ²	Percent automotive		Total patents issued ¹	Automotive total ²	Percent automotive
1899.....	25,435	3,681	14.5	1920.....	39,649	10,146	25.6
1900.....	26,418	3,451	13.1	1921.....	41,162	11,642	28.3
1901.....	27,292	3,250	11.9	1922.....	40,041	10,268	25.7
1902.....	27,776	3,288	11.8	1923.....	40,561	10,982	27.0
1903.....	31,582	4,006	12.7	1924.....	45,265	9,167	20.2
1904.....	30,824	3,578	11.6	1925.....	49,274	9,370	19.0
1905.....	30,270	3,682	12.2	1926.....	47,352	9,034	19.1
1906.....	31,806	3,850	12.1	1927.....	44,118	8,624	19.5
1907.....	36,469	4,996	13.7	1928.....	45,564	8,941	19.6
1908.....	33,514	4,854	14.5	1929.....	48,191	9,336	19.3
1909.....	37,261	6,184	16.6	1930.....	47,955	9,118	19.0
1910.....	35,807	5,915	16.5	1931.....	54,703	11,911	21.8
1911.....	33,927	7,289	21.5	1932.....	56,417	11,552	20.5
1912.....	37,573	7,073	18.8	1933.....	51,197	10,679	20.8
1913.....	35,624	6,713	18.9	1934.....	47,348	9,408	20.0
1914.....	41,660	7,296	17.5	1935.....	44,502	8,334	18.7
1915.....	44,752	6,221	13.9	1936.....	44,349	7,905	17.9
1916.....	45,729	10,352	22.6	1937.....	42,832	7,264	17.0
1917.....	42,581	9,335	21.9	Total.....	1,564,951	298,923	19.1
1918.....	39,776	10,380	26.1				
1919.....	38,395	9,788	25.5				

¹ Source: Patent Office Gazette. Figures include design patents.

² Represents patents selected for Research Library, Automobile Manufacturers Association, which include patents concerning the construction, design, and use of motor vehicles.

EXHIBIT No. 100

Source: Automobile Manufacturers Association Magazine]

THE FOLLOWING PARTICIPATED IN THE CROSS-LICENSING AGREEMENT 1915-1925.

Allen Motor Company.
The American Electric Car Company.
Anderson Electric Car Company.
Anderson Motor Company.
Apperson Bros. Automobile Company.
Auburn Automobile Company.
Austin Automobile Company.
Barley Motor Car Company.
The Bartholomew Company.
Bethlehem Motors Corporation.
Brewster & Company.
Briggs-Detroit Company.
Briscoe Motor Company, Inc.
Briscoe Motor Corporation.
Buick Motor Company.
Cadillac Motor Car Company.
Cartercar Company.
J. I. Case Threshing Machine Company.
Chalmers Motor Company.
The Chandler Motor Car Company.
Checker Cab Manufacturing Corporation.
Cleveland Automobile Company.
Cole Motor Car Company.
Commonwealth Motor Company.
Consolidated Car Company.
Crow Motor Car Company.
James Cunningham Sons & Company.
Daniel Motor Car Company.
Daniels Motor Company.
Geo. W. Davis Motor Car Company.
Detroit Electric Car Company.
Detroit Motors Company.
Dodge Brothers.
Dorris Motor Car Company.
Dort Motor Car Company.
duPont Motors, Inc.
Durant Motor Company of Indiana, Inc.
Durant Motor Company of Michigan.
Durant Motor Company of New Jersey.
Durant Motor Company of New York, Incorporated
Elgin Motor Car Corporation.
Elkhart Carriage & Harness Manufacturing Company.
Empire Automobile Company.
Essex Motors.
The Gardner Motor Company, Incorporated.
Grant Motor Car Corporation.
Gray Motor Corporation.
Great Western Automobile Company.
Hackett Motor Car Company.
Hal Motor Car Company.
The Handley Knight Company.
Hanson Motor Company, Atlanta, Georgia.
The Haynes Automobile Company.
H. C. S. Motor Car Company.
Hewitt Motor Company.
Holmes Automobile Company.
Hudson Motor Car Company.
Hupp Motor Car Company, Michigan.
Hupp Motor Car Corporation, Virginia.
Imperial Automobile Company.
Jackson Automobile Company.
Jackson Motors Corporation.
The Thomas B. Jeffery Company.
Jones Motor Car Company.
Jordan Motor Car Company.

King Motor Car Company.
The Kissel Motor Car Company.
Kline Motor Car Corporation.
Kline Car Corporation.
Krit Motor Car Company.
LaFayette Motors Company.
The Lexington-Howard Company.
Lexington Motor Company.
Liberty Motor Car Company.
Lincoln Motor Company, a Michigan Corporation.
Lincoln Motor Company, Delaware.
Lincoln Motor Company, Michigan.
Locomobile Company of America, West Virginia.
The Locomobile Company, Delaware.
Locomobile Company of America, Inc., New York.
Lozier Motor Company.
Maxwell Motor Company, Inc., Delaware.
Maxwell Motor Corporation, West Virginia.
McFarlan Motor Company, Indiana.
McFarlan Motor Corporation, Delaware.
Mercer Automobile Company, New Jersey.
Mercer Motors Company, Delaware.
Mitchell-Lewis Motor Company, Wisconsin.
Mitchell Motors Company, Incorporated, New York.
Monroe Motor Company.
Moon Motor Car Company.
The Motor Car Manufacturing Company.
Mutual Motors Company.
The Nash Motors Company.
National Motor Vehicle Company.
National Motor Car and Vehicle Corporation.
Nordyke & Marmon Company.
Oakland Motor Car Company.
Olds Motor Works.
Paige Detroit Motor Car Company.
W. A. Paterson Company, Flint, Michigan.
The Pathfinder Company.
The Peerless Motor Car Company.
Riedmont Motor Car Company, Incorporated.
Pierce Arrow Motor Car Company.
Pilot Motor Car Company.
Premier Motor Manufacturing Company.
Premier Motor Corporation, Delaware.
Premier Motors Incorporated, Indiana.
Pullman Motor Car Company.
The Rauch & Lang Carriage Company.
Rauch & Lang, Incorporated.
Regal Motor Car Company.
Reo Motor Car Company.
Rickenbacker Motor Company.
Roamer Motor Car Company.
The Rollin Motors Company.
Root & Van Dervoort Engineering Company.
R & V Motor Company.
Saxon Motor Company, Detroit, Michigan.
Saxon Motor Car Corporation, New York.
Scripps Booth Company.
Scripps Booth Corporation.
Simplex Automobile Company.
William Small Company.
F. B. Stearns Company.
Stephens Motor Car Company, Incorporated.
Stevens-Duryea Company.
Stevens-Duryea, Incorporated.
The Studebaker Corporation.
Stutz Motor Car Company, Indiana.
Stutz Motor Car Company of America, New York.
The Templar Motors Corporation.

Templar Motors Company.
 The Touraine Company.
 United Motor Company.
 Velie Motor Vehicle Company.
 Velie Motors Corporation.
 The Waverley Company.
 Westcott Motor Car Company, Indiana.
 Westcott Motor Car Company, Ohio.
 C. H. Wiils & Company.
 Wills Sainte Claire, Incorporated.
 The Willys-Overland Company.
 The Winton Company.
 Yellow Cab Manufacturing Company.

TRUCK MEMBERS

Acme Motor Truck Company.
 American-LaFrance Fire Engine Company, Inc.
 Argo Motor Company, Incorporated.
 The Argo Electric Vehicle Company.
 Atterbury Motor Car Company.
 The Autocar Company.
 Avery Company.
 The Borland Grannis Company.
 Brockway Motor Truck Company.
 The Clyde Cars Company.
 The Commerce Motor Car Company.
 Corbett Motor Truck Company.
 Denby Motor Truck Company.
 Diamond T Motor Car Company
 Duplex Truck Company.
 Federal Motor Truck Company.
 General Motors Truck Company.
 General Vehicle Company, Incorporated.
 Graham Brothers.
 Gramm Motor Truck Company.
 International Harvester Corporation.
 Inter-State Motor Company.
 Kelly-Springfield Motor Truck Company.
 Kentucky Wagon Manufacturing Company.
 Kleiber & Company, Incorporated.
 Lewis Spring and Axle Company.
 Lyons-Atlas Company.
 Maccar Truck Company.
 Mack Brothers Motor Car Company.
 Maibohm Motors Company.
 Mason Motor Truck Company.
 The Milburn Wagon Company.
 The Moline Automobile Company.
 Moline Plow Company.
 Moreland Motor Truck Company.
 Oneida Motor Truck Company.
 Rainier Motor Corporation.
 Republic Motor Truck Company.
 Rowe Motor Manufacturing Company.
 Sanford Motor Truck Company.
 The Sayers & Scovill Company.
 The G. A. Schacht Motor Truck Company.
 Selden Motor Vehicle Company.
 Selden Truck Corporation.
 Service Motor Truck Company.
 Service Motors, Incorporated.
 Standard Motor Truck Company.
 Standard Steel Car Company.
 Sternberg Motor Truck Company.
 Stewart Motor Corporation.
 Traylor Engineering and Manufacturing Company.
 Walter Motor Truck Company.

Ward Motor Vehicle Company.
 The White Company.
 The White Motor Company.
 J. C. Wilson Company.

MEMBERS OF THE ASSOCIATION WHO SIGNED THE EXTENSION OR SUBSTITUTE
 CROSS-LICENSING AGREEMENT 1925-1930

Anderson Motor Company.
 Apperson Automobile Company.
 Auburn Automobile Company.
 Brewster and Company.
 J. I. Case Threshing Machine Company.
 Chandler-Cleveland Motors Corporation.
 The Chandler Motor Car Company.
 Checker Cab Manufacturing Corporation.
 Cleveland Automobile Company.
 Chrysler Corporation.
 Cole Motor Car Company.
 James Cunningham, Son and Company.
 George W. Davis Motor Car Company.
 Dodge Brothers.
 Dodge Brothers, Incorporated (a Maryland Corporation).
 duPont Motors, Incorporated.
 Durant Motor Company of Indiana, Inc.
 Durant Motor Company of Michigan.
 Durant Motor Company of New Jersey.
 Elcar Motor Company.
 Falcon Motors Corporation.
 H. H. Franklin Manufacturing Company.
 The Gardner Motor Company, Inc.
 General Motors Corporation.
 Gray Motor Corporation.
 Haynes Automobile Company.
 H. C. S. Cab Manufacturing Company.
 H. C. S. Motor Car Company.
 Hupp Motor Car Company, Inc.
 Jordan Motor Car Company, Inc.
 The Kissel Motor Car Company.
 Kleiber Motor Company.
 Lincoln Motor Company.
 Locomobile Company of America, Inc.
 Maxwell Motor Corporation.
 The McFarlan Motor Corporation.
 Mercer Motor Car Company.
 Moon Motor Car Company.
 The Nash Motors Company.
 Nordyke and Marmon Company.
 Paige-Detroit Motor Car Company.
 Peerless Motor Car Company.
 Peerless Motor Car Corporation.
 The Pierce-Arrow Motor Car Company.
 Premier Motors, Inc.
 Rauch and Lang, Inc.
 Reo Motor Car Company.
 Rickenbacker Motor Company.
 Roamer Motor Car Company.
 Rollin Motors Company.
 The F. B. Stearns Company.
 The Studebaker Corporation.
 Stutz Motor Car Company of America, Inc.
 Velie Motors Corporation.
 The Westcott Motor Car Company.
 Wills Sainte Claire, Incorporated.
 The Willys-Overland Company.

TRUCK MEMBERS

Acme Motor Truck Company.
 American-LaFrance Fire Engine Company, Incorporated.
 Atterbury Motor Car Company.
 The Autocar Company.
 The Clydesdale Motor Truck Company.
 Commercial Truck Company.
 Corbitt Motor Truck Company.
 Diamond T Motor Car Company.
 Duplex Truck Company.
 Fageol Motors Company.
 Federal Motor Truck Company.
 The Garford Motor Truck Company.
 Garford Truck Company.
 General Motors Truck Corporation.
 Graham Brothers.
 The Kelly-Springfield Motor Truck Company.
 Kleiber Motor Truck Company.
 LaFrance-Republic Corporation.
 Larrabee Deyo Motor Company, Incorporated.
 Mason Motor Truck Company.
 Mcreland Motor Truck Company.
 The National Cab and Truck Company.
 Rainer Trucks, Incorporated.
 Relay Motors Corporation.
 Republic Motor Truck Company, Incorporated.
 Sanford Motor Truck Company.
 The Sayers and Scovill Company.
 The G. A. Schacht Motor Truck Company.
 Selden Truck Corporation.
 Service Motors, Incorporated.
 Standard Motor Truck Company.
 Stewart Motor Corporation.
 Traylor Engineering and Manufacturing Company.
 Walke Vehicle Company.
 Walter Motor Truck Company.
 Ward Motor Vehicle Company.
 The White Motor Company.
 Yellow Cab Manufacturing Company.

MEMBERS OF THE ASSOCIATION WHO SIGNED THE SECOND EXTENSION CROSS-LICENSING AGREEMENT 1930-1935

Acme Motor Truck Corporation.
 American-LaFrance and Foamite Corporation.
 Atterbury Motor Car Company.
 Auburn Automobile Company.
 The Autocar Company.
 Checker Cab Manufacturing Corporation.
 Chrysler Corporation.
 Continental Automobile Company.
 Corbitt Truck Company.
 James Cunningham, Son & Company.
 Diamond T Motor Car Company.
 Duesenberg, Incorporated.
 Duplex Truck Company.
 duPont Motors, Incorporated.
 Flear Motor Company.
 Fageol Motors Company.
 Federal Motor Truck Company.
 H. H. Franklin Manufacturing Company.
 The Gardner Motor Co. Incorporated.
 Graham-Paige Motors Corporation.
 General Motors Corporation.
 Hupp Motor Car Corporation.
 Jordan Motor Car Company, Incorporated.

The Kissel Motor Car Company.
 Kleiber Motor Company.
 LaFrance-Republic Corporation.
 The LeBlond-Schacht Truck Company.
 Lincoln Motor Company.
 Locomobile Company of America, Incorporated.
 Macear Truck Company.
 Marmon Motor Car Company.
 Meon Motor Car Company.
 Moreland Motor Truck Company.
 The Nash Motors Company.
 Peerless Motor Car Corporation.
 The Pierce-Arrow Motor Car Company.
 Plymouth Motor Corporation.
 Reo Motor Car Company.
 The Sanford Motor Truck Company.
 The Sayers & Seovill Company.
 Selden Truck Corporation.
 Standard Motor Truck Company.
 The F. B. Stearns Company.
 Stewart Motor Corporation.
 S. P. A. Truck Corporation.
 The Studebaker Corporation.
 Stutz Motor Car Company of America, Incorporated.
 Walker Vehicle Company.
 Ward Motor Vehicle Company.
 The White Motor Company.
 The Willys Overland Company.

MEMBERS OF THE ASSOCIATION WHO SIGNED THE THIRD EXTENSION CROSS-
LICENSING AGREEMENT 1935-1940

The Autocar Company.
 Auburn Automobile Company.
 Checker Cab Manufacturing Corporation.
 Chrysler Corporation.
 The Corbitt Company.
 Diamond T Motor Car Company.
 Duesenberg, Incorporated.
 Federal Motor Truck Company.
 General Motors Corporation.
 Graham-Paige Motors Corporation.
 Hudson Motor Car Company.
 Hupp Motor Car Company.
 International Harvester Company.
 The Le Blond-Schacht Truck Company.
 Lincoln Motor Company.
 The Nash Motors Company.
 Pierce-Arrow Motor Corporation.
 Reo Motor Car Company.
 Stewart Motor Corporation.
 Studebaker Corporation.
 Stutz Motor Car Company of America, Incorporated.
 The White Motor Company.
 The Willys-Overland Company.

EXHIBIT No. 101

[Source: Automobile Manufacturers Association magazine]

GROWTH OF MEMBERSHIP, AUTOMOBILE MANUFACTURERS ASSOCIATION

Number of members by years

Year:	<i>No. of Members</i>	Year:	<i>No. of Members</i>
1913 (Charter Members) ---	75	1926 (Charter Members) ---	102
1914 -----	97	1927 -----	77
1915 -----	98	1928 -----	76
1916 -----	104	1929 -----	74
1917 -----	108	1930 -----	72
1918 -----	121	1931 -----	65
1919 -----	120	1932 -----	61
1920 -----	129	1933 -----	53
1921 -----	128	1934 -----	44
1922 -----	131	1935 -----	39
1923 -----	127	1936 -----	36
1924 -----	129	1937 -----	34
1925 -----	110	1938 -----	34

"EXHIBIT No. 102", introduced on p. 362, is on file with the Committee.

"EXHIBIT No. 103", introduced on p. 362, is on file with the Committee.

EXHIBIT No. 104

[Prepared by James McEvoy, Patent Counsel, General Motors Corporation]

REASONS FOR TAKING OUT OR ACQUIRING PATENTS; ALSO, LIST OF CORPORATIONS PATENTS OTHER THAN THOSE HELD UNDER LICENSE NOW USED IN THEIR PRODUCTS (NOT INCLUDING DELCO PRODUCTS, FRIGIDAIRE AND SOME OF THE OTHER DAYTON GROUP) APPLICATIONS, LIBRARY, SEARCHES AND INVESTIGATIONS

The Corporation owns a large number of patents which were acquired in various ways: namely,

1. Patents owned by companies whose stock or property it acquired,
2. Patents which it purchased,
3. Patents which were applied for by its employees and assigned to it.

Many of the patents owned by the companies it acquired, such as Delco-Remy, Harrison Radiator, New Departure, etc., were of considerable value. None of them, however, owned any patent which prevented a competitor from making a like product, although to avoid the patent a more costly or inefficient device might have been necessary.

Neither the Corporation nor any of its subsidiaries ever purchased any patent unless it was felt necessary to do so to protect some article or device, or part thereof, they intended to manufacture. No attempt has ever been made to "build up" a patent situation or acquire all of the patents which might relate to a particular thing so that no one else could manufacture something like the article it was proposed to produce. Nothing has ever been manufactured that could in any sense be considered as a "monopoly." The nearest that it has ever come to this is "Ethyl Gas" and "Freon Gas." Ethyl Gas is not the only anti-knock fuel that can be made, but it is the cheapest and most practical. No one is obliged to use it and it might really be considered as a luxury. It might be noted, however, that General Motors has never itself marketed these products but granted licenses to the two corporations which are doing so. The same might be said of the Freon Gas used by Frigidaire.

All of the mechanical and electrical devices upon which patents are held only cover details of construction, some of which are of course very valuable, but none of them control the only way to do the job, so to speak. Probably the three most valuable mechanical patents the Corporation now owns are the Fisher Ventilation System, the Synchronesh and the Fuel Pump patents. Although I believe it is generally agreed that the Fisher window is a considerable improvement over any other type of window, the only automobile company which has, so far, infringed on it is Chrysler.

The Synchronesh, in some form, was used by nearly all competitive cars without the Corporation's consent and without any of them asking for a license except Packard. These transmissions were made by Borg-Warner who undertook to hold their customers harmless against our patents, but after suit was instituted, a settlement was made by granting them a license. I might say here that charges of infringement were served on all of the automobile companies purchasing the transmission from Borg-Warner, but none of them were made parties to the suit.

The patents the Corporation owns covering the starting, lighting, and ignition situation are also quite valuable, particularly the vacuum ignition control patent, but a license has been given under all these patents to its only real competitor, The Electric Auto-Lite Company. (I will deal with the Frigidaire situation in a separate memorandum.)

The many patents taken out by its employees are upon structures or devices which were mostly invented in the course of the development of the article to which they apply. They were taken out, not because the Corporation intended to exploit them against its competitors, but to protect itself against persons who might think of the same thing and obtain a patent thereon and then sue the Corporation for infringement. The Corporation's patents have proven to be very valuable from this aspect alone as many charges of infringement have been abandoned upon the complainant's being shown our patents; also, a good many of the suits filed against the Corporation were abandoned after consideration by the Plaintiff of the patent the Corporation held on the device or article involved.

The Corporation has been involved in four hundred and forty-six interference proceedings since 1922 in the Detroit office. (The interferences at Dayton, Frigidaire, Delco-Remy, etc., I will deal with in a separate memorandum.) Every one of these, of course, related to an invention made by one of the employees of the Corporation, or in a few cases, to applications which it acquired from outsiders. In almost all of these cases, except those which have not as yet been determined, a settlement was made to the advantage of the Corporation, that is, it was successful in the proceedings or settled them by taking a license in most of the cases and paying no royalty. The few proceedings which have been decided against the Corporation have, so far, given us no trouble as the article or device covered thereby is not being used. If it had not filed these applications, a patent, of course, would have been granted to the other party and the Corporation would have been faced with a charge of infringement and doubtless a good many suits would have been brought against it. The Corporation, of course, has not used all of its patents. The larger majority of them are ineffective to cover its actual products for various reasons. Many applications are filed for experimental devices which never go into production because of failure to give satisfactory results. Many others are filed to cover devices going into production but which later become obsolete by reason of changes and improvements. It, of course, might happen that an improvement amounting to invention is made, especially in respect to a machine or method of manufacture which is very good, but the use thereof would require the scrapping or discarding of a large quantity of machinery, the replacing of which would be so costly as to make it unprofitable to use the invention. I do not believe, however, that there are many such cases and I cannot at the moment think of any instance of the kind within the Corporation. It is a point, however, which the Government will, in all probability, lay some stress upon, and it may attempt to use the testimony of Frazer which I have dealt with in a separate memorandum as well as some of the other persons who testified in a similar manner before the House Committee. I think the only thing to do is to wait and see what they say regarding this matter, and I will be much surprised if they will be able to produce anything that cannot be refuted.

A large number of the Corporation's patents are used in its various products and some are being infringed. These infringements mostly relate to accessories or parts, such as replacement parts for Delco-Remy starters, certain types of bearings, fuel pump injector, spark plugs, etc. While charges of infringement have been served on most of these infringers, it has not been deemed wise to institute but few suits, because the number of infringing articles produced is not great enough to cause serious competition, also the greater number of infringements relate to parts, and the Corporation's experience with this type of litigation has not been very happy and the results accomplished have not at all been commensurate with the expense. Further, the patents covering these infringements are, in most cases, not so strong as to make the Patent Section feel confident that they will be sustained.

The Patent Section has never thought it worth while to keep a record of all the Corporation's patents used in its various products. I have what I believe to be a fairly complete list of these patents but, to maintain an absolutely accurate

one would seem to serve no good purpose, particularly as a large number of such patents merely cover very minor details, also the design of the products is being continually changed. The same thing applies to our competitors, and while we could make and maintain such a list by constant revision, it would profit us very little if any. This does not apply, of course, to any important patents. We would know if any such was being used, but I am referring to patents relating to small details of slight importance and little value.

The Patent Section watches very closely all structures covered by patents under the license agreements held by the Corporation, so as to be sure that it does not pay royalty upon something it is not using.

The licenses held by the Corporation and those it has granted are dealt with in a separate memorandum.

I am also enclosing a separate memorandum setting forth what I believe to be most of the Corporation's patents (other than those it has purchased or holds under license) used in its present projects, or which have been used at various times during the past few years. It is, of course, obvious from the number of patents relating to some of the products (i. e. headlights) that all of them could not be "controlling" but relate to details of construction in most cases and which are frequently changed.

Delco-Remy and Frigidaire patents, as well as some of the other Dayton group, are not included and these will be treated in another memorandum.

DEVICES OR ARTICLES COVERED BY CORPORATION'S OWN PATENTS (OTHER THAN FRIGIDAIRE AND DELCO) AND NOW BEING USED IN ITS VARIOUS PRODUCTS OR WHICH MAY HAVE BEEN USED DURING THE PAST FEW YEARS

Headlights, Taillights and Devices used in connection therewith. (Design patents, Testing Apparatus, etc.)

1,471,679 P	Bell	1,913,196 GM	Falge et al.
1,531,307 GM	Persons	1,927,319 GM	Michel et al.
1,591,572 L	Stimson	1,954,806 GM	Falge and Godley
1,615,548 GM	Michel	1,987,697 GM	Mead and Michel
1,640,831 GM	Hunt	2,014,429 GM	Falge and Godley
1,671,086 L	Stimson	2,014,592 GM	Schwarze
1,743,834 L	Stimson	2,033,381 GM	Koubek & Michel
1,795,940 GM	Falge	2,033,382 GM	Koubek
1,807,350 L	Stimson	2,033,387 GM	Michel
1,812,476 GM	Godley	2,061,001 GM	Michel
1,848,675 L	Stimson	Des. 104,009 GM	Agramonte
1,859,674 GM	Michel	Des. 106,925 GM	Mead
1,871,505 L	Falge & Brown	1,894,910 P	Morgan et al.
1,874,138 L	Stimson	1,894,911 P	Morgan et al.
1,884,076 GM	Michel	1,919,200 P	Childs
1,896,887 GM	Falge et al.	2,111,585 GM	Falge
1,902,997 GM	Godley	2,050,724 GM	Mead & Michel
2,086,345 GM	Winkelmeyer	2,054,919 GM	Anibal
2,050,726 GM	Michel		

Engine Crankcase Ventilation Patents

1,529,188 GM	Kettering	1,849,000 GM	Ellis
1,682,998 GM	Summers	1,869,553 GM	Ellis
1,683,039 GM	Hack	2,056,755 GM	Welch
1,713,262 GM	Cochrane	2,056,762 GM	Bar
1,761,944 GM	Taylor		

Balancing Machine Patents

1,731,833 GM	Van Degrift	1,839,134 GM	Van Degrift
1,750,608 GM	Summers	2,008,161 GM	Van Degrift
1,761,945 GM	Van Degrift et al.	2,037,443 GM	Van Degrift
1,822,860 GM	Summers et al.		

Plain Bearing Patents

1,761,926 GM	Landers	1,783,438 GM	Landers
--------------	---------	--------------	---------

Instrument Panel Patents

1,668,521 GM	Zubaty	1,967,548 P	Bartels
--------------	--------	-------------	---------

Valve Lash Adjuster Patents

1,571,175 P	Bazzoni	1,996,807 GM	Hallett
1,950,590 GM	Berry		

Spark Plug Insulators and Method and Apparatus Used in Their Manufacture

2,069,059 GM	Fessler	1,458,376 P	Anderson
2,106,598 GM	Fessler	1,710,995 GM	McDougal
2,122,960 GM	Schwartzwalder	1,713,851 GM	McDougal

Spark Plug Electrodes

1,872,065 GM	Duffendack & Ra- bezzana	1,976,295 GM 2,001,888 GM	Raldolph Raldolph
--------------	-----------------------------	------------------------------	----------------------

Spark Plug Manufacture

1,609,735 GM	Rabazzana	Re.15,585 P	Sauereisen
1,862,981 GM	Rabazzana	2,071,571 GM	Rabazzana, Ford & Kirk
1,619,969 GM	Champion		
1,358,116 GM	Schmidt		

Plastic Bronze Bearing Development

1,581,073 P	Gilman	2,106,590 GM	Boegehold et al
2,033,321 GM	Boegehold et al	2,126,660 P	Pogue
2,044,897 GM	Boegehold et al		

Engine Mounting Patents

2,108,515 GM	Summers		
--------------	---------	--	--

Lock Patents

2,020,606 GM	Harris		
--------------	--------	--	--

Ventilating Windows

2,087,821 GM	Simpson	1,542,595 P	Anibal
2,048,605 GM	Fisher	Re. 18,866 P	Wright

Winton Diesel Engine

1,581,083 P	Gilman	2,014,932 GM	Hallett
1,981,913 GM	Fielden	2,043,014 GM	Shoemaker
1,996,807 GM	Hallett	2,126,609 GM	Brill

12-cylinder Airplane Engine

2,054,926 GM	Caminez	2,098,718 GM	Caminez
2,024,334 GM	Caminez	2,011,855 GM	Gilman
2,001,866 GM	Caminez		

Electro-Motive

1,871,163 GM	Dilworth	106,919 GM	Hamilton et al
2,104,787 GM	Blomberg	106,920 GM	Hamilton et al
Des. 106,918GM	Hamilton et al		

Clutches

2,045,557 GM	Almen et al	2,073,146 GM	Gardiner
1,930,276 GM	Lenz & Adams	2,100,464 GM	Almen
1,930,277 GM	Lenz & Adams	2,045,557 GM	Almen et al

Brakes

1,937,997 GM	Townsend		
--------------	----------	--	--

Valve Manufacture

1,644,021 GM	W. S. Knudsen	1,351,949 L	Renault Company
1,679,977 GM	W. S. Knudsen		

Radiator Cores

2,011,853 GM	Emons	2,071,584 GM	Shippy
--------------	-------	--------------	--------

Electric Gages and Ammeters

2,047,763 GM	Bacon	1,791,786 GM	Bacon
1,942,529 GM	Bacon	1,761,917 GM	Helgeby
1,919,504 GM	Eshbaugh	1,761,909 GM	Eshbaugh
1,847,251 GM	McKinley	1,761,908 GM	Eshbaugh
1,805,447 GM	Eshbaugh	1,749,366 GM	Zubaty
1,742,697 GM	Eshbaugh	1,723,035 GM	Helgeby
1,737,303 GM	Eshbaugh	1,685,992 GM	Eshbaugh
1,735,919 GM	Eshbaugh		

Bourdon Tube Gages

2,079,914 GM	McKinley	1,937,879 GM	Eshbaugh
2,079,913 GM	McKinley	1,922,616 GM	Chisholm
1,937,928 GM	Wedin	1,909,857 GM	Eshbaugh
1,937,888 GM	Harada		

Temperature Indicators

1,847,438 GM	Moulding		
--------------	----------	--	--

Cable Winding Machine

1,847,453 GM	Webb	1,847,455 GM	Webb
1,847,454 GM	Webb	1,848,982 GM	Webb

Oil Filters

2,047,793 GM	McKinley	1,830,742 GM	McKinley
1,940,316 GM	McKinley	1,806,560 GM	McKinley

Liquid Level Gages

1,930,546 GM	Bacon	1,902,933 GM	Zubaty
--------------	-------	--------------	--------

Odometer

1,919,493 GM	Zubaty		
--------------	--------	--	--

Fuel Pumps

1,695,534 P	Carter	2,003,420 GM	Babitch et al
1,847,445 GM	Randolph et al	2,104,446 GM	Babitch et al
1,957,753 GM	Babitch	2,104,448 GM	Babitch et al

Paint Spraying Machines

2,083,633 GM	Brackett.	2,083,634 GM	Brackett.
--------------	-----------	--------------	-----------

Independent Suspension and Adjustments Thereof

2,063,704 GM	Slack.	2,092,611 GM	Olley.
2,083,627 GM	Youngren.	2,092,612 GM	Olley.

Radio

2,104,800 GM	Grandy & Doane.	2,108,530 GM	Ellis & Archer.
--------------	-----------------	--------------	-----------------

Car Heaters

2,034,228 GM	Darrah & Hardiman.	2,034,252 GM	Schutt & Darrah.
--------------	--------------------	--------------	------------------

Frames

2,096,996 GM Parker.

Rear Axle Construction

2,061,009 GM Rothrock. 1,993,912 YT Austin.

The following is a list of patents used on a number of the Corporation products which are not mentioned above, none of which are of any great importance:

1,916,520 GM	Manning (Valve Guide).
1,746,220 GM	Manning (Valve Spring Vibration Damper).
1,905,925 GM	Manning (Connecting Rod).
2,069,066 GM	Harbour (Pedal Pad).
2,004,258 GM	Waterbury (Radiator and Front Fender Support).
1,942,550 GM	Helgeby (Heat Treatment of Cables).
1,694,770 GM	Cram (Oil Pump Screen).
1,684,550 P	Mallory (Carburetor).
1,983,606 GM	Geise (Fans).
1,991,567 GM	Morgan (Crankshaft Twisting Machine).
2,058,932 GM	Wilson (Muffler).
2,063,743 GM	Kamrath (Filter Element).
2,071,583 GM	Schutt (Method of Making Bellows).
2,126,643 GM	Kamrath (Air Cleaner and Silencer Assembly).
1,826,403 GM	O'Brien (Tube Bending Apparatus).
2,081,237 YT	Jantsch (Propeller Shaft Center Bearing).
1,967,548 P	Bartels (Arrangement for producing multiple total reflections)
1,973,847 GM	De Orlow & Lakin (Rear View Mirror Mounting).
1,976,360 GM	Neuman (Painting mask).
1,979,989 GM	Neuman (Painting mask for wheels).
1,991,582 GM	Sterling (Valve Tappet).
1,998,703 GM	Bramley-Moore (Vehicle Jack).
2,004,298 GM	Shoemaker (Universal Joint).
2,030,647 GM	McMillin & Taub (Splash Oiling System).
2,047,771 GM	Dolza (Body Stabilizer).
2,050,723 GM	McMillin (Splash Feed).
2,069,052 GM	Webb (Casing Machine).
2,069,059 GM	Fessler (Method of Producing Ceramic Ware).
2,018,524 GM	Burton (Combined Shock Absorber and anti-roll device).
2,093,859 YT	Austin (Vehicle Body).
2,018,547 GM	Nyland (Gear Lapping Mach.).
2,027,577 GM	Crane (Anti-roll device).
2,083,718 GM	Kull & Rasmussen (Steering Lever Joint).

(200 patents in all.)

It is to be noted that the Corporation had outstanding a number of licenses taken from various individuals and corporations during the years 1924 to 1937 inclusive and which were used in connection with some of the patents above mentioned.

The Corporation owns a large number of patents relating to processes, machinery, and designs. Many of these are very valuable from a practical standpoint but are not controlling, nor could we prevent anyone from accomplishing the same result, so far as the processing and machinery patents are concerned, although perhaps in some cases our structures are superior. The design patents are not of very much account except in the case of some of the hardware (hinges, doorknobs, radiator ornaments, etc.) produced by Ternstedt, except in a good many cases I have no doubt the patents have prevented some competitors from using a similar design. The legal position regarding design patents is so weak in the United States, where if a very slight change is made in the design, the patent is held not to infringe, that really only patents on small articles can be maintained.

APPLICATIONS

There are now pending in the United States Patent Office 489 applications relating to the group of units handled by the Detroit office and 561 for Dayton, New Departure and Frigidaire, or 1,050 in all. About two hundred of the structures covered by these applications are now being used, none, however, are of any real importance, and by the time the patents are issued, in all probability

the structures will be so changed as to take them out of the patents. The principal value of the applications and the patents issued thereon will be to prevent someone else from getting a patent on a similar structure thereby rendering the Corporation liable to a charge of infringement.

LIBRARY, SEARCHES AND INVESTIGATIONS

The Detroit Office maintains a very extensive library of patents and its collection thereof of things relating to the automobile is very complete and numbers about eight hundred thousand (800,000) United States and Foreign patents. At the Dayton and Bristol offices, the collection of patents on the articles they look after is also very complete and they possess about four hundred thousand (400,000). These patents are supplemented by English, Canadian, and German publications showing in very brief form each patent granted in those countries. France has no such publication but we have all the French patents of importance relating to the automobile. The patents of the other countries are not of sufficient importance to warrant maintaining a complete collection thereof, but on all of the more important searches and investigations, they are examined.

We possess a number of books of value from a patent standpoint and also maintain and keep up to date a digest of all articles appearing in the leading United States and European Journals relating to the automobile and the other products of the Corporation, particularly radio.

While the Patent Section maintains a search office in Washington, the maintaining of the library is of the utmost importance as with the great number of investigations it is required to make, if it were not for the library, we would be compelled to send all searches to Washington which would mean increasing the force there from six men to probably twenty-five or more; also, the delay in receiving reports on the searches would in many cases not only be embarrassing but frequently might prove quite dangerous as we are very often required to make a search of something which it is desired to put into production almost immediately, and we have sufficient material in the Library to come to a conclusion without sending it to Washington.

EXHIBIT No. 105

[From files of General Motors Co.]

LITIGATION INSTITUTED ON BEHALF OF GENERAL MOTORS CORP.

Twenty-five suits (treating the suits instituted by Delco-Remy as one, which is practically the case as only one was tried, see explanation on page 2 of the memorandum immediately following—entitled "List of Patent Suits in which General Motors or its Subsidiaries were Plaintiffs").

Eight of these suits were instituted, really, to protect our licensees and largely because of their insistence, as they did not think it fair that they should be paying royalties while a number of other concerns were infringing. The cases so brought were:

1926—*Harrison Radiator Co. vs. Trenton Auto Radiator Works.*

1927—*Frigidaire vs. A. L. Namm & Sons.*

1930—*Frigidaire Corp. vs. Fedders Mfg. Co.*

1931—*Frigidaire Corp. vs. Zerozone Corp.*

1933—*Frigidaire Corp. vs. Adams & Tagliabue Mfg. Co.*

1933—*General Motors vs. Brooklyn Union Gas Co.*

1933—*Frigidaire Corp. vs. A. I. Namm & Sons, Inc.*

1934—*General Motors vs. S. Davidson & Bros.*

1934—*General Motors vs. Younker Bros.*

None of the above cases ever came to trial, all were settled by defendants' taking license or ceasing to infringe.

The suit of the *Corporation vs. The Horten-Knodel Distributing Company* is against a Norge Refrigerator dealer in Dayton under certain Frigidaire patents. This suit is really a counter one to the one instituted by Norge against General Motors.

Three of the cases were really not instituted by General Motors. These were:

1. *General Motors and Laminated Shim Co. vs. Lehr Auto Supply, Inc.* The Laminated Shim Company held an exclusive license under this patent and brought the suit, the Corporation being joined because title to patent is in its name.

2. *General Motors Research Corp. and Dayton Rubber Mfg. Company vs. B. F. Goodrich Company.* Dayton Rubber Mfg. Co. holds an exclusive license and instituted the suit, General Motors being joined as owner of patent. (The title to patent was originally in the Research and it was the original plaintiff; when patent transferred to G. M., bill was amended.)

3. *Berry and General Motors vs. Bohn Aluminum and Brass Co.* Berry owns patents and G. M. has exclusive license, but must grant sub-licenses at request of Berry.

The Corporation is taking no part in the trial of any of the three above cases. It is not contributing to their expense, nor will it profit from any recoveries, except if Berry recovers, he will pay back expense of interference case advanced by General Motors.

The two suits on Radiator ornaments brought against Franklin Die Casting Company and Faith Manufacturing Company were brought because these two concerns are copying the ornaments and selling them at very low prices. These are not of much importance except a number of the Corporations dealers have complained that their replacement sales are being affected. Both suits are pending.

The Ternstedt suit against Nyers on Window Regulators was lost, the patent being held invalid. The structure was deemed quite important and Nyers was selling, I understand, a large number of the devices.

The other Ternstedt suit is against the Motor Products Corporation under the Window Ventilation patents. It is set for trial in October, the day not definitely determined.

AC Spark Plug Company vs. Cooper, who was a dealer for Motor Improvements. We decided to sue him on several of the AC Filter patents but afterwards concluded to discontinue the suit.

Delco-Remy Cases

For years Delco-Remy has been much disturbed over the great number of parts of the starting system that were being made by concerns all over the country and sold at a price very much less than that charged by it, also some of these parts were not as good as they should be. It, therefore, decided to bring suit against the principal manufacturers under the patents covering these parts. About 125 separate suits were filed. The defendants joined together and after negotiations, it was determined to try one case in New York which was illustrative of all of them. The Lower Court held the patents valid and infringed but the Court of Appeals for the Second Circuit held them invalid. The real reason, however, as to why the suit was lost was because the Court, and particularly Judge Hand, felt that the owner of a car had the right to repair the starter if one of the parts broke or wore out and that he could buy these from anyone he chose or have them made and irrespective of whether or not the parts were patented. This viewpoint is not reflected in the opinion but Judge Hand dwelt upon it at great length at the hearing. A very similar suit brought by Auto-Lite and decided a few weeks before ours was decided against it by that same Court so that now, at least in the Second Circuit, the "gyp" parts business is on a firm foundation and we can do nothing about it. One of the cases was instituted in Chicago and we have not as yet determined whether to try it or not. I, personally, have very little hope of winning it.

Most of the suits instituted by the Corporation were brought to protect its licensees, as mentioned above, or to try to prevent the defendants from making "gyp" parts. The only ones which in any way could be considered as an attempt on the part of the Corporation to set up a "monopoly" were the suits on the Wolf patent, the Thompson Synchro-mesh and the Oil Pump.

A brief statement of each of these might be helpful—

Wolf patent.—This was one of the patents purchased from the old "Isko Refrigerator Co." which went bankrupt in Chicago. Wolf was the chief engineer and really the originator of the company; Mr. Henry Joy, I believe, was the principal financial backer. Wolf took out a good many patents covering various features of the refrigerator, but the one we sued on was a very broad patent covering the general idea of a Household Refrigerator which had never been done before. He did not originate anything really new, his invention consisting in reducing well known refrigerator parts to a size that could be used for household purposes and he employed SO₂ gas instead of ammonia as a refrigerant. All of the refrigeration companies except Electro-Lux and General Electric were using the Frigidaire construction and most of them, including Copeland and General Necessities, had copied the Frigidaire refrigerator without any change at all.

Mr. Rector felt that the Wolf patent was too broad to sustain, but after his death, his partner, Mr. Samuel Hibben, made a study of this patent, as well as some six or seven others which Frigidaire owned, and came to the conclusion that they were all valid and should be sustained. It was, therefore, determined to bring suit although I felt very doubtful of the outcome in the face of Mr. Rector's opinion. Suit was instituted against both Copeland and General Necessities as these presented the best cases, their refrigerators being exact copies of Frigidaire. Before the suits were reached, Mr. Hibben died and Drury Cooper was substituted in his place. After considering the matter, Cooper came to the conclusion that we should be able to sustain the Wolf patent, but he did not believe the others were strong enough to warrant going to trial upon them. So they were withdrawn. (These patents are detailed under the Delco-Light Company vs. Copeland Sales in the list of suits. The patents were, at the time this suit was brought, in the name of Delco-Light, but were transferred to Frigidaire before the General Necessities suit was instituted). The case was tried before Judge Tuttle who felt that while Wolf had done a very clever job, it did not amount to invention and this was also the attitude of the Court of Appeals. Of course, if this patent had been sustained, the Corporation would have contested this type of refrigerator and concerns like General Necessities, Copeland, Nizer, etc. would have been enjoined and forced to take a license. As I have said before, however, General Electric and Electro-Lux did not infringe, also Kelvinator had been given a license, so with Frigidaire's three principal competitors either not infringing or holding a license, it would seem that not much could be said about "monopoly." Upon losing this case, the suit against Copeland Sales Company was discontinued.

The Thompson Transmission.—This was brought to the attention of the Corporation in January 1924 by Mr. Henry Crane upon whom Thompson had called and shown his device. From a patent standpoint, there was nothing especially new about it except some improvements, mostly controls, which he had originated, but which apparently made it much more efficient than any previous similar device. The transmission, however, as Thompson had it in 1924 was not perfected sufficiently to install it in a car and arrangements were made with him to develop it with the assistance of the Research and Cadillac. This was finally done in the latter part of 1928 and in December of that year, an agreement was made with him whereby the Corporation possessed an exclusive license for three years and thereafter either exclusive or non-exclusive at its election. Thompson was to be paid a minimum annual royalty of \$65,000, \$75,000 and \$85,000 for the years 1929, 1930 and 1931 respectively, and \$100,000 per year thereafter if the license remained exclusive. In 1929 Thompson received \$65,849.25 in royalties. In 1930 he became an employee of the Corporation and the patents were purchased for \$360,000; he was also to receive one-half of any royalties collected by the Corporation up to \$150,000. He did receive about \$15,000 and then they were compounded for \$50,000.00.

While a very careful search of the prior art was made at the time the agreement with Thompson was made, it afterwards developed that a number of applications were filed in the Patent Office which went into interference with some of his applications. It was thought wise to acquire some of these applications as well as certain English patents to protect some improvements made in the device. Others of the interferences we contested and were successful in all of them except one of no importance. The cost of these proceedings and the purchase of applications and patents amounted to something over \$100,000. The entire development, including patent expense, amounted to more than \$1,000,000. The transmission was a very distinct advance over anything else on the market and while the Corporation felt that its investment and initiative should be protected it was not averse to granting licenses and did grant the same to Packard, Rolls-Royce and Peugeot. It would have granted others had it been approached, but Borg-Warner, without contacting at all with the Corporation, through its subsidiary, Detroit Gear and Machine Company, approached all of the other automobile companies and told them it could make the transmission for them and would protect them against any possible patent complications. When these transmissions began to appear, we complained to both Detroit Gear and Machine Company and Borg-Warner and had a number of interviews but could make no headway with them whatever. They contended that our patents were of no account and that they were dominated completely by a group of patents issued to one Murray and that the best they would do would be to exchange licenses. The Murray patents had been offered to the Corporation several times and we had made an exhaustive study of them and could see no merit whatever in any

of them. At the last interview we had with Murray we did offer \$100,000 as we felt to get rid of their nuisance value, it would be worth that amount.

Fuel Pump.—For many years (at least since 1924) the Research and AC Spark tried to discover some form of pump that would take the place of the Vacuum Tank. Both organizations found that the essential element of the pump was the diaphragm. All kinds of metals and other things were tried, but none of them would "stand up" long enough to be practical, either cracking or becoming crystallized. All of this work cost a great deal of money. Finally, when the development looked rather hopeless, a man named William C. Carter came to AC with a diaphragm made of a very good grade of linen impregnated with linseed and upon which he had a patent recently granted (1932). This diaphragm proved satisfactory and the patent was purchased for \$100,000. Stewart-Warner had also been working for years on pumps and had produced an electrical pump which I understand is quite good but more expensive than the AC pump.

As soon as the AC pump was introduced, it met with immediate favor, both on account of its cheapness as well as its efficiency, and the greater number of cars were equipped with it. No licenses were granted except to Ford Motor Company who paid no royalty but promised (no binding contract) to give AC its business. Stewart-Warner deliberately infringed. AC did not discuss giving it a license and I do not think the corporation would have granted it one even if asked. Suit was instituted and while Judge Tuttle decided in favor of the Carter patent and disregarded some patents of Stewart-Warner which they had set up in a counter claim, before the decree was signed, we made a settlement with them by their agreeing to quit making pumps which infringed. AC also took over the equipment which was being used, and paid, I believe, \$50,000 for it.

The suit of Guardian Trust Company of Cleveland, Ohio, against Anthony Cottone is included because, while the Corporation is not a party, it holds a license from the Trust Company under certain refrigeration patents. The Trust Company agreed to sue infringers of these patents and, Frigidaire, ascertaining that such infringement existed, insisted that suit be brought. The Corporation is taking no part in the case nor contributing anything to the expense thereof.

The suit instituted by Frigidaire and Penn Electric Switch Company (one of its licensees) against Moore was under its so-called Cold Control patents. These patents were believed good and a number of refrigeration companies had taken licenses. The Court held the patents not infringed.

EXHIBIT No. 106

[Prepared by James McEvoy, Patent Counsel, General Motors Corporation]

SCHEDULE OF LITIGATION COSTS OF GENERAL MOTORS CORPORATION

1924	Litigation	-----	\$103,320.32	1931	Litigation	-----	199,910.94
1925	"	-----	29,325.14	1932	"	-----	369,821.86
1926	"	-----	28,354.29	1933	"	-----	224,315.77
1927	"	-----	124,885.03	1934	"	-----	220,323.53
1928	"	-----	136,493.77	1935	"	-----	332,679.64
1929	"	-----	174,193.97	1936	"	-----	209,521.84
1930	"	-----	112,152.25	1937	"	-----	262,711.74

"EXHIBIT No. 107," introduced on p. 367, is on file with the Committee.

"EXHIBIT No. 107-A," introduced on p. 367, is on file with the Committee.

"EXHIBIT No. 108," introduced on p. 369, is on file with the Committee.

"EXHIBIT No. 109," introduced on p. 369, is on file with the Committee.

EXHIBIT No. 110

HISTORY OF THE GROWTH OF THE LONG PENDING PATENT APPLICATION EVIL
Prepared and Distributed by the Patent Section of the General Motors Corporation

The charge against the long pending application, repeated by court after court and commissioner after commissioner, is that it stifles progress of science and the useful arts instead of promoting it. Fundamentally the principles of the tactics involved are:

1. A patent right hidden from the public during a long period of development of the art.

2. Asserting that right when the development has enriched the trade to a point where exploitation of the patent promises to be most profitable.

The objections to the practice, aside from the unpleasantness of surprise attack, are—

1. The reward which should go to the inventor of a successful device is too often wholly or partially diverted to an applicant who has done nothing but make an unsuccessful attempt. Unfortunately the bounds of an invention are set by words. The applicant with the unsuccessful device need but employ an adroit patent attorney, keep his application pending many years, and when a successful device appears on the market, have his attorney make a careful search for words that will describe real or fancied similarities between the successful development and the abandoned attempt. The man who promoted progress of the useful arts must then pay tribute to the man who contributed nothing, but whose attorney is adept in discovering analogies.

2. Owing to the secrecy of the proceeding the public is unable to find out what may be manufactured without fear of domination by patents. This seriously hampers legitimate business.

3. The period of monopoly is increased beyond that authorized by Congress, and the ones that benefit the most are the very ones that most abuse the patent system.

These tactics have been employed in at least three different ways in the past century. Two of these ways have been cut off, one by legislation, and one by judicial legislation. The third has so far been unsuccessfully attacked.

1. THE FIRST METHOD: THE REVIVED APPLICATION

Under the law of 1836 there was no time limit within which the applicant must reply to the Office action. The result was that many applications were presented anew after a lapse of years, given the benefit of the early filing date of the original case, and issued as patents to dominate industries that had grown up in the meantime. This procedure was brought to an end by the Patent Act of 1870, setting two years as the time within which an applicant must reply to an Office action.

2. THE SECOND METHOD: THE BROADENED CLAIM REISSUE

Under the reissue statute a patent issued with narrow claims could be reissued at any time with broadened claims and asserted against industry which had developed without its aid. This evil was cut off by the decision of the Supreme Court in *Miller vs. Brass Company* (104 U. S. 783), holding that claims may not be broadened by reissue unless the reissue is applied for within two years of the grant of the original patent.

3. THE THIRD METHOD: WILFUL DELAYS BY APPLICANTS IN PROSECUTION OF PATENT APPLICATIONS

This is the method now in vogue. The application is simply kept pending by amending it within the time allowed by law. This has been the practice since 1870 in the Telephone case (79 O. G. 1362) an attempt was made to combat the practice by having the patent declared void on the ground that the delay in the Patent Office amounted to fraud. The charge was not sustained, and the Court established as the law that an applicant is entitled to wait until the last day of the period allowed by the law before amending his case, without being chargeable with laches or fraud. Since then in an effort to combat the evil of long pendency, the period for reply has been successively reduced to one year and recently to six months. The practice has also been attacked by several commis-

sioners of patents under their power of regulating proceedings in the Patent Office. Not only has no lasting improvement been accomplished, but the situation is worse than it has ever been.

The following record of the efforts to maintain the patent system as a system for promoting the progress of science and the useful arts is an interesting record of human struggle.

PRIOR TO THE ACT OF 1870

The examination system was adopted in 1836. This Act set no time limit for reply by applicants to Office actions. If the applicant withdrew his application, two-thirds of the filing fee was returned to him.

Robinson says (Vol. 2, p. 194):

"Prior to the act of 1861 this question of the abandonment of the application by delay was determined upon general principles regarding diligence and good faith with the public. By that act, however, it was provided that all applications must be completed and prepared for examination within two years after the filing of the petition, and in default thereof should be considered as abandoned by the applicants unless the Commissioner were satisfied that the delay was unavoidable. This provision was reenacted in the act of 1870, and appears in the Revised Statutes, with the addition that a failure to prosecute the application within two years after any action thereon, of which notice has been given to the applicant, shall also work its abandonment."

The last change was not accomplished without the usual previous abuse and a struggle to correct that abuse.

The abuse that had grown up was the practice of reviving applications after the lapse of a long period of years, asserting there had been no abandonment of the invention, obtaining a patent, and attacking enterprises that had developed in the meantime. In *Colgate vs. Western Union*, 14 O. G. 943, decided in 1878, a number of instances of the practice are set out. The Colgate case was itself an example of an aggravated form of the abuse. The inventor filed his application in 1848, withdrew two-thirds of his fee in 1851, roamed in the West for seven years, refiled his case in 1858, and finally received his patent in 1867. The invention was a very simple one—providing copper wires with an insulating coating of rubber—but the Court held the inventor had not abandoned the invention and sustained the patent.

In *Adams vs. Jones* (1 Fisher's Patent Cases 527), "an application was made in 1850, and was never withdrawn, and the patent was granted in 1857, and was sustained. Mr. Justice Grier says, that by the application filed in the Patent Office, the inventor makes a full disclosure of his invention, and gives public notice of his claim for a patent; and that the delay afterward interposed by the mistakes or obtuseness of public officers, where gross laches cannot be imputed to the applicant, cannot affect his right." The reference to public notice by filing application for patent is interesting, for according to a decision of the Secretary of the Interior in 23 O. G. 629, the rule of secrecy was not adopted by the Office until 1851. The Rules of Practice for 1852-53, published on page 445 of the Commissioner's report for that period, contain a provision for secrecy of pending applications for patent.

With the adoption of the rule of secrecy the whole basis of the reasoning on which the decision in *Adams vs. Jones* was based disappeared. But though the basis for the right disappeared, the right persisted. In *Johnsen vs. Fassman* (1 Woods 138) an application made in 1856 was rejected in 1857 for want of novelty. The applicant took no further steps until 1866, when he took an appeal which resulted in the granting of a patent. In the meantime patents for substantially the same invention were issued to other inventors. During four of the nine years the applicant was a citizen of a State in rebellion. There was no withdrawal of his application. It was held that no direct or implied abandonment was shown.

In *McMullin vs. Barclay* (5 Fisher's Patent Cases 189) an application was made in 1855, and was finally rejected in 1856 on appeal. It was not withdrawn, but nothing more was done in regard to it until 1867, when the specification was amended and patent granted. It was held there was no abandonment and that the lapse of time was satisfactorily explained.

But there were other cases in which long delays in prosecution were held fatal. In *Bevin vs. The East Hampton Bell Company* (9 Blatchford 50) application was filed in 1852 and the patent granted in 1869. During ten years of this period the

inventor watched others develop the invention, and, although able to do so, did nothing to secure his patent. The delay was held fatal.

There was a similar holding of laches in *Marsh vs. Sayles* (5 Fisher's Patent Cases 610) where 18 years' delay remained unexplained.

In 1876 the United States Supreme Court sustained a patent having a gap of eight years in its prosecution (*Smith vs. Goodyear Dental Vulcanite Co.*, 3 Otto 486), but it is very interesting to read the dissenting opinion of Justice Bradley, for it was Justice Bradley who wrote the decision in *Miller vs. Brass Company*, of which more will be said:

"I dissent from the judgment of the court in this case, on the ground that the patentee, having duly made his application for a patent in 1855, and the same having been three times rejected, must be considered as having abandoned the same, inasmuch as no further effort was made to obtain a patent until eight years afterwards, without any pretense that the patentee was engaged in perfecting his invention and in the meantime the invention which he claims as his had come into general public use. The application for patent made in 1864 was a new and independent application, and should be treated as such. As the public had enjoyed the use of the invention for more than two years prior to this application, the patent should be declared invalid. Great injustice will, in my judgment, be done to the public to allow a patent obtained under such circumstances to stand. The public had a right to suppose that no further application would be made. The levy of a tribute now on all the dentists of the country who have brought the plate into public notice and use seems to me a species of injustice. The delay of the patentee, in fact, is made to operate to his benefit instead of his prejudice, his patent being made to run eight years longer than it would have done had it been granted when first applied for: So that the public is still further injured by sustaining the patent as finally granted. It is too common a case that associated companies, in order to maintain some valuable monopoly, look about to see what abandoned invention or rejected application, or ineffective patent, can be picked up, revamped, and carried through the patent office, and by the aid of ingenious experts and skillful counsel succeeded in getting the desired protection. I think that the courts ought to be strict in maintaining the rights of the public in such cases. And the present case seems to me to be one in which we ought to hold the patent invalid as against those rights."

During the decade preceding the passage of the Act of 1870 providing two years for reply to Office actions, the Commissioners of Patents had not been idle in combating the long pendency of applications. Although the Statute of 1861 merely provided that all applications must be completed and prepared for examination within two years after filing the petition, upon penalty of abandonment, Commissioner Holloway construed the law to authorize him to hold applications abandoned in which no action was taken by the applicant for two years after a rejection by the Office. In his report for 1865 Commissioner Theaker expressed doubt as to the legality of this practice and recommended legislation authorizing it. The Commissioner, in the same report, recommends the extension of the two-year rule to broadened claim reissues:

"This period of two years is recognized in several instances as the measure by which the rights of an inventor shall be determined; and I am convinced that if the same idea is extended to another case not now within its scope, the occasion for much serious injustice will be removed. Under the existing law a patent is taken out in which the inventor makes a clearly defined claim to a particular feature. The claim, it may be, does not cover all that is described in the specification or shown in the drawing, and whatever is thus left unclaimed may be used by any person, unless protected by a previous patent. Some enterprising manufacturer, who is keen enough to recognize the value of that which the inventor did not deem it worth his while to appropriate, invests his capital and begins to furnish the public with a valuable article; and after this the inventor applies for a reissue of his patent and an extension of his claim so as to give him the monopoly of that which he had before left open to the use of the world. If it appears, upon examination, that the original specification described the art or device in question, and that the holder of the patent was actually the original inventor, he is entitled to a reissue in such terms as to preclude the use of such device, except upon such conditions as he may grant. It would not be difficult in this manner to entrap a person into such an arrangement of his business or employment of his means as to leave him at the mercy of the inventor, or to compel him to

pay an exorbitant royalty, when the patent is reissued with a broader claim. In my opinion it would be a judicious amendment of the law, and would prove an effective safeguard to the rights of innocent parties, if the privilege of reissuing a patent in such terms as to broaden the claim were restricted to the first two years of the life of a patent, leaving reissues for other purpose to be granted at any time, as at present."

Commissioner Fisher took up the fight on long pending applications. In his report for 1869 he is very emphatic in his condemnation of the practice:

"Some provision is also needed limiting the time during which applications shall be permitted to lie in the Patent Office, after adverse action, before the next step by way of appeal or amendment is taken. Much injury to the business of the country is likely to result from the construction lately given to the law by the Judge of the Supreme Court of this district, by inflicting patents upon the nation for inventions which have long been in public use. This is, in effect, to create a monopoly, instead of affording encouragement to inventors.

"There are hundreds of these cases in the Office, many of which are being bought up upon speculation, and vigorously pressed for issue. One of these, lately filed, was withdrawn in 1851, and has now been refiled, after a lapse of nineteen years, when the substance of the invention which it seeks to monopolize has gone into use in nearly every form in which a well-known agricultural implement is now manufactured."

The decision of the District Supreme Court to which the Commission referred was undoubtedly *Ex parte John W. Cochran*. Cochran's application was filed in 1859, and rejected the same year. No appeal was taken, and on February 20, 1860, the application was withdrawn and the balance of the fee was refunded. In 1868 Cochran filed a new application which was rejected by the Commissioner upon the ground of abandonment. During the eight year gap in prosecution Cochran busied himself with the making and marketing of other inventions. The Supreme Court of the District of Columbia reversed Commissioner Fisher but in spite of that fact he declined to issue the patent. Later the Act of 1870 was passed, containing a validating clause, and under it Commissioner Fisher's successor issued the patent. Commissioner Fisher was vindicated, however, for the patent was held invalid for laches in *United States Rifle Company vs. Whitney Arms Company*, 11 O. G. 373.

SINCE 1870

Undoubtedly the passage of the Act of 1870 with its two year rule put a stop to the old form of abuse. There must also have been considerable doubt as to whether an applicant was entitled to take his full two years for reply to office actions for Robinson says on page 194, Vol. 2, of his treatise, published in 1890:

"But this provision of the statutes does not confer upon the applicant a right to two years of inaction between each action of the Patent Office. Unreasonable delay for any period is still abandonment. These statutes merely declare that a delay of two years is prima facie unreasonable, and thus throw upon the applicant the burden of proving that in his particular case the delay was justified."

It remained for the Telephone case, decided in 1897, to make it absolutely safe to be dilatory in prosecuting patent applications.

In the early part of this period the favorite abuse seems to have been the broadened claim reissue. In his report for 1877, Commissioner Spear refers to the growth of this practice:

"It is perhaps unavoidable, even under our system, which provides for an examination as to patentability, that patents of little or no value, and for unimportant improvements, should be very frequently granted. Many of these patents are used more to retard the progress of the arts than to advance them, and in such ways as to tend rather to bring the patent system into disrepute. For illustration, patents are often granted for inventions more or less crude, for machines capable of operation mechanically, but not capable of profitable operation, and not valuable commercially, or for processes which, for like reason, fail to become of practical value. These patents sometimes lie dormant until, in the progress of the arts and by the efforts of more practically successful or ingenious inventors, the goal is ultimately reached, and inventions are perfected and made practically useful, in which, however, are embodied the germs found in some of these old patents.

"One of the greatest hardships, and the source of much complaint, has been the reissue of such old patents with claims covering machines subsequently invented and practically the first to operate successfully. To such an extent has this been carried, that when a man had really made a valuable invention, it was necessary for him to examine the records of the Office, and ascertain what old patents could be found which might be reissued to cover his invention; and it has been a matter of prudence to secure such patents before investing in the manufacture of an invention liable to be dominated in that way."

Five years later, in 1882, Justice Bradley delivered the opinion of the United States Supreme Court in *Miller vs. Brass Company*, 104 U. S. 783, holding invalid a broadened claim reissue applied for more than two years after the grant of the original patent. His appreciation of the injustice of this situation was just as keen as in the *Vulcanite case* in which he handed down the strong dissenting opinion quoted above. He says:

"Patents have been so expanded and idealized, years after their first issue, that hundreds and thousands of mechanics and manufacturers, who had just reason to suppose that the field of action was open, have been obliged to discontinue their employments, or to pay an enormous tax for continuing them. * * * * Every independent inventor, every mechanic, every citizen, is affected by such delay" (in applying for reissue), "and by the issue of a new patent with a broader and more comprehensive claim. The granting of a reissue for such a purpose, after an unreasonable delay, is clearly an abuse of the power to grant reissues, and may justly be declared illegal and void. It will not do for the patentee to wait until other inventors have produced new forms of improvements, and then, with the new light thus acquired, under pretense of inadvertence and mistake, apply for such an enlargement of his claim as to make it embrace these new forms. Such a process of expansion carried on indefinitely, without regard to lapse of time, would operate most unjustly against the public and is totally unauthorized by the law. In such a case, even he who has rights, and sleeps upon them, justly loses them."

This decision closed the door to the second method of abuse.

THE MODERN FORM OF LONG PENDING APPLICATION EVIL

In his report for 1887, Commissioner Hall gives a good description of the third and modern method of procedure:

"Under Section 4894 R. S., applicants who desire to prolong their applications and postpone action therein have an ample opportunity to do so. There are two classes of persons who apply for patents, one composed of those who are exceedingly anxious to obtain their patents at the earliest practical moment, the other, of those who desire to prolong the issue of their patents and to keep the application pending in the Patent Office to the very latest date possible. The second class embraces the more powerful, rich, and influential parties, who are either the inventors or the assignees of the inventors. This section of the statute enables the second class of persons to keep their applications pending in the Office for years before their patents issue. In the meantime they are engaged in manufacturing and putting upon the market the article or improvement, but warning the public that the patent is applied for, the effect of which is to give them the absolute control and monopoly of the invention and to deter all other inventors from entering upon the same field of invention and from manufacturing the article.

"The manner in which this delay is effected may be briefly explained: The applicant files his application and is allowed two years within which to complete or perfect it. Any action of the Office requiring change or modification or some formal correction can be followed under this section by a further delay of two years before the applicant is required to take any action in response. At the expiration of the two years he perhaps makes some amendment or change in the character of his claims. This involves a corresponding action on the part of the Office, and, however prompt and speedy this action may be, the applicant is permitted another two years before any responsive action can be compelled from him; and so the matter may be continued. There are applications now in the Office which have been kept alive nine or ten years, and the Office is powerless to compel speedier or earlier action on the part of the applicants."

Obviously the practice was still in its infancy, for nine or ten years no longer represents the extreme length to which this practice is carried.

Commissioner Hall's remedy is much the same as that favored by Commissioner Robertson today:

"I earnestly recommend that Section 4894 be so modified that there shall be vested in the commissioner of patents a discretion to declare any application forfeited for want of prosecution whenever he shall be satisfied that such order should be entered. This power is possessed by all tribunals who have the control of litigation and matters of this character."

In 1891 Commissioner Simonds recommended the following legislation to cure the abuse:

"An amendment compelling an applicant to take action upon his application at least once in every six months, in lieu of once in two years, as at present; and a further provision that a patent shall in no case live for more than twenty years from the date of the first application therefor. The adoption of such amendments would put an end to keeping applications for patents pending many years prior to issue."

Commissioner Seymour remarked upon the abuse in his reports for 1894, 1895, and 1896. On April 15, 1895, he put into effect amendments to the rules of practice providing that if applications were not amended within six months after an Office action, the Examiner should reexamine them on his own motion, and, presumably, make the action final. The amendments also provided that in every case pending more than five years in which the record raises the presumption of intentional delay in prosecution, the Examiner may require the applicant to show cause why the case was not more rapidly prosecuted, and if he determines that the delays have been intentional and unreasonable, he may reject the case for that reason. Commissioner Seymour had some doubt as to the legality of the new rules and on June 18, 1897, following the decision in the *Telephone case*, they were dropped.

The *Telephone case* (79 O. G. 1362) was a suit by the United States to cancel the Berliner patent No. 463,569 on the ground that it was delayed in issuance by connivance between the assignee and the Patent Office officials so that the Telephone Company would get the benefit of the extended period of monopoly. It was held that no fraud was shown, and that an applicant was entitled to take the full two years specified by statute in amending his application.

Commissioner Duell was very active in his efforts to shorten the period of pendency of patent applications. In his report for 1898 he recommended the following legislation:

"An amendment to limit the life of all patents so that they shall expire not later than twenty years after the applications for the same are filed.

"At the present time it is possible to keep applications alive for an indefinite number of years. That this practice does not promote the progress of invention is self-evident."

He again attacks this practice in his report for 1899:

"At the present time an application can be kept alive in the Office for an indefinite number of years, although there is no good reason why at least ninety per cent of all patents cannot be issued within one year after filing applications therefor. The practice of keeping applications pending in the Patent Office is, in my opinion, reprehensible, as it certainly does not promote the progress of invention, but rather tends to stifle it. If an application does not become involved in an interference it should not be permitted to remain in the Patent Office more than three years without abridging its life of seventeen years. Were it not for the number of appeals, all interferences could be disposed of within that time. To meet any case of unusual hardship discretion might be lodged with the Commissioner of Patents to extend the proposed limit of three years."

Although the Act of 1897 changed the time for amendment from two years to one year, and it was hoped that this would remedy the situation, in his next report Commissioner Duell is even more emphatic that the situation demands remedy:

"The most serious defect, however, follows from the power to keep applications in the Office for indefinite times through delays in amending the same. The Act of March 3, 1897 (decreasing the time for amendment from 2 years to 1 year), was intended to prevent or check this evil; but it has failed of its

purpose. At the present time about 75% of the patents granted are issued within one year after being filed, and were it not for the fact that applications are unduly delayed at least ninety per cent would issue within that time. The rights of the public would be protected and very seldom would an injustice be done to an inventor if a provision was incorporated into the patent laws providing that unless an application became involved in an interference it should not be permitted to remain in the Patent Office more than three years without abridging its life of 17 years.

"The records of the Office show that there are pending 4,829 applications filed prior to Jan. 1, 1898. Three of these applications were filed in 1880, 1 in 1881, 4 in 1882, 3 in 1884, 3 in 1885, 13 in 1886, 7 in 1887, 13 in 1888, 19 in 1889, 23 in 1890, 45 in 1891, 64 in 1892, 103 in 1893, 154 in 1894, 368 in 1895, 992 in 1896 and 3,011 in 1897.

"It will be seen, therefore, that an application may be kept alive indefinitely, if it be desired. While the list above given embraces only such applications as were filed under the law as it existed prior to Jan. 1, 1898, yet 10 years from now a similar list will undoubtedly be given, provided the statutes are not amended, for the only difference lies in the fact that amendments now have to be made within a year after the official action instead of 2 years under the prior Act. A law which permits this should be corrected."

Commissioner Duell's prophecy as to the condition of work in the Patent Office at the end of the next decade was amply fulfilled.

In 1911 Commissioner Moore takes up the battle, confident that changing the time for amendment from one year to six months will solve the difficulty:

"I also respectfully recommend the passage of the bill * * * * requiring that an application for patent shall be prosecuted within six months after any action by the Patent Office. The present period within which the applicant is allowed to amend is one year, and under the existing practice there have been many instances of cases being amended just within the one year limit in order to keep them alive, they thus serving as drag-nets in many cases to catch inventions along similar lines which may be subsequently applied for, thereby involving inventors in expensive interference proceedings. It has been the effort of the Office to get the old cases out of the Office whenever possible consistent with good work. The Office has been severely criticized recently, especially in the last year or two, for allowing applications, particularly those owned by corporations, to rest in the Office for such long periods as to really have the effect of extending the patent period in case such applications are later passed to issue. Instructions have been repeatedly given to the examining corps to as far as possible get rid of all such cases as are delayed intentionally by the applicant or his attorney. Had this bill passed it would have almost entirely overcome that criticism."

Commissioner Ewing's crusade against the long pending application is fresh in the minds of practicing attorneys. The following quotations from his reports declare his purpose, and set forth his methods of attack:

"I hope to be able to make it impossible for an applicant to prosecute his application by dilatory or time-consuming amendments by refusing to enter amendments which are not proper responses to Office actions, and in appropriate cases holding the applications to be abandoned. I am also considering the propriety and wisdom of making these old applications public. The statute contains no provision against it. There is, however, a rule of the Office, under which they have all been filed, which declares that the applications shall be preserved in secrecy.

"Little advantage will result from getting rid of the old cases now pending if others are permitted to take their places. I believe that with proper administration it is possible to limit the time during which an application may be kept pending in the Office to less than 5 years, and perhaps to less than 3 years, without unduly reducing the applicant's right to consideration of his case.

* * * * *

"Few applicants who keep their cases in the Office for many years deliberately are entitled to favorable consideration. It is believed that the consequence of the application of this conviction on the part of the Commissioner to the delayed cases will satisfy applicants of the wisdom of prosecuting their cases promptly. Every effort will be made to eliminate this evil of long pending applications. If during the course of a year this has been substantially accomplished, it is believed that no legislation will be necessary to

prevent the recurrence of the evil. Should my efforts, however, along this line prove to be ineffectual, I shall in my next report to Congress recommend appropriate corrective legislation.

"In conclusion it may be stated that on an average applications are in the Office about two years, and in the vast majority of cases this length of time is sufficient for thorough consideration of the applicant's claims (Report for 1913).

"I believe that it is possible with proper administration so to limit the time during which applications are kept in the Office that very few will exceed three years, and this without impairing an applicants' right to consideration of his case. * * * The progress made toward eliminating the evil of long-delayed applications has been sufficiently encouraging to warrant the present belief that legislation is unnecessary." (Report for 1914.)

Commissioner Ewing was very sanguine about the results to be obtained by employment of his methods. In his report for 1916 his tone was triumphant:

"When the Supreme Court began the reformation of the practice respecting reissues with the decision in *Miller v. Brass Company*, it had to deal with an abuse quite analogous to that of delayed applications in the Office. One result of the line of decisions in which they corrected these abuses was that a smaller number of reissue applications were filed and that the applications were more carefully scrutinized by the Patent Office. Down to 1882 there had been granted 250,000 patents and 10,000 reissues, or about 1 in 25. From 1882 to 1916 there were granted 900,000 patents and less than 4,000 reissues, or about 1 in 225.

"It will be found from the foregoing tables that when the Office began to reform the conditions respecting old cases there were about 4,300 which had been on file 5 years or longer. It will be seen that they have been reduced to less than 1,700. I believe that during the coming year this number will be reduced by another thousand and the evil be substantially eliminated.

"The reform in the treatment of applications in the Office to prevent long delay is believed to be as extensive and as important as the reform effected by the Supreme Court respecting reissue patents. It is, in fact, an application of the spirit of the decision in *Miller v. Brass Company* in dealing with another development of the same evil tendency which the Court there combated."

After his resignation no comment on the evil of long pending applications appears in the Commissioners' reports. For a few years the number of old cases is faithfully reported and then that, too, disappears. The campaign is dropped. The stream of business in the Patent Office drifts back into its old channels. Patent applications again become stagnant in the Office, at times for almost a generation. In 1927 a fresh effort is made to cure the condition. Again the remedy applied is to shorten the time for reply to Office actions, this time to six months. The following charts show the success achieved in a half century of effort by many Commissioners, many Congresses and many organizations of the patent bar:

CHART No. 1
 APPROXIMATE PERCENTAGE OF CASES PENDING 3 YEARS OR MORE IN PATENT OFFICE 1880 TO 1930

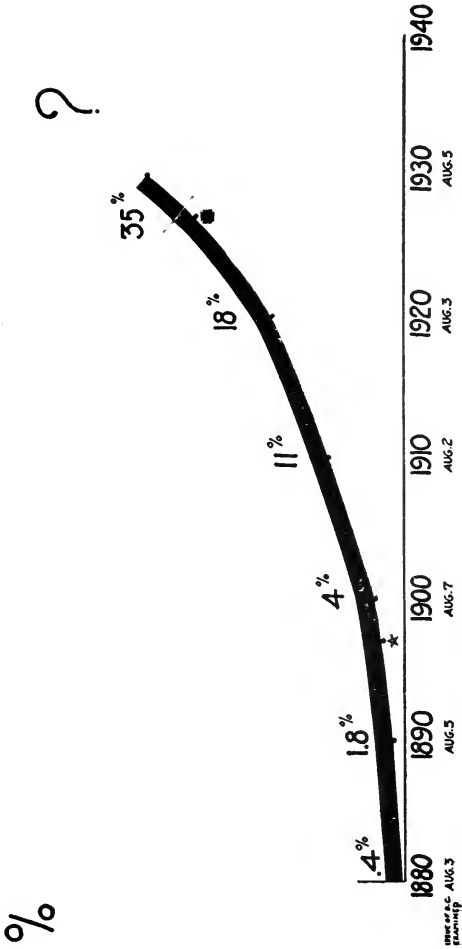

* TIME FOR AMENDMENT REDUCED FROM 2 YRS. TO 1 YR.
 • TIME FOR AMENDMENT REDUCED TO 6 MO.

CHART No. 2

A STUDY OF 143 IMPORTANT PATENTS SHOWING, BY DECADES, THE AVERAGE LENGTH OF TIME THE APPLICATIONS WERE PENDING

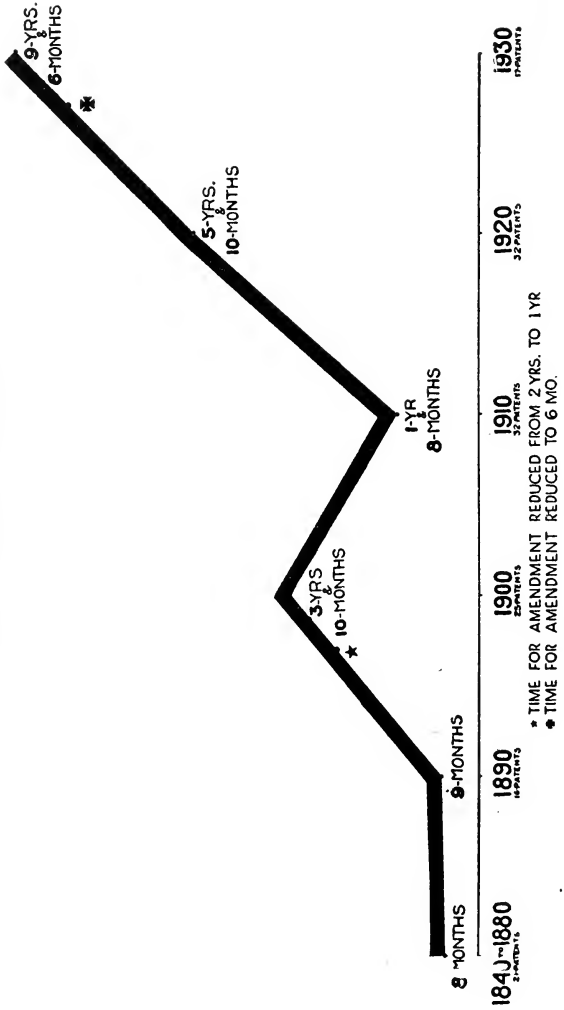

Chart No. 1¹ is submitted, not as statistically complete, but as accurately depicting a trend. Substantially the same trend is shown by Chart No. 2.²

The reports of the Commissioners of Patents throw some light on the subject: In 1880, Commissioner Marble was disturbed by this condition in the Patent Office:

"Some of the examining divisions are several months behind with their work, which accounts in some measure for the proportionately less number of patents granted as compared with former years, many of the applications filed during the year remaining undetermined at its close. This is a serious difficulty, because inventors as a class are impatient of delay."

In 1900 Commissioner Duell reports that 75% of the patents granted issue within one year.

In 1913 Commissioner Ewing reports that applications are in the Office two years on an average.

Mr. W. D. Shoemaker is responsible for the following figures:

AVERAGE TIME OF PENDENCY OF PATENT APPLICATIONS

1917-----	1 year, 9 months.
1921-----	1 year, 10 months.
1928-----	2 years, 7 months.
1929-----	2 years, 10 months.

The patents from which the data to plot Chart No. 2 was obtained are listed at the end of this report. They were obtained from a number of sources. It is believed that the list is thoroughly representative of the important patents issued during the periods indicated. The average for the decade ending in 1930 may be attacked on the ground that too few patents are included in the study and too many of them are aggravated cases of long pendency. This may prove to be a fair criticism. It is, however, a difficult matter to ascertain what are the important patents among those so recently issued. It is quite likely that a more liberal selection would reveal a lower average of pendency, possibly seven years or eight years, instead of nine or ten. But it is not believed that any representative selection of important patents will do other than confirm what this curve shows—that the length of time important patents are pending in the Patent Office is much greater than the average,—the data available indicates they are pending two or three times as long; and that that length of time is rapidly increasing.

The Court of Appeals of the Seventh Circuit in the recent litigation on the Cowles patent 1,103,567, accurately depicted the situation in a decision, later withdrawn, from which the following is quoted:

"This tendency to thus extend the monopoly period seems to be a growing one. Not how promptly may a patent be secured, but rather how long may the proceedings in the Patent Office be extended, seems to be the 'preferred' mode of procedure. And this is particularly true if the patent is to be operable in a rapidly developing art. During the pendency of the application, the inventor enjoys, to a limited extent the privileges and advantages arising from his 'patent applied for' notices and warnings. When demand for the article is established, he presses his application, and a patent issues. Frequently, amendments to the claims and specifications appear several years after the original application is filed, and strangely enough, these amendments particularly fit some other devices or combinations that have just appeared on the market and give promise of extensive use."

Is it not fair to draw the following conclusions from the facts presented?

1. The evil of the long pending application has its roots deep in the history of the patent system.
2. The abuse is more prevalent now than ever before.
3. Remedies previously applied have proven utterly inadequate.

Is it not also proper to deduce that the criticism of the patent pool springs largely from the great prevalence of the long pending patent application evil? It is true the United States Supreme Court has approved the principle of the patent pool, but this will not save it from attack in Congress. There can be no question but that the long pending patent application greatly aggravates the condition complained of. A seventeen year monopoly as a reward for invention is accepted as desirable for the general welfare, but is it accepted that a pool of patents, some of which may have been pending in the Patent Office anywhere from

¹ Supra, p. 709.

² Supra, p. 710.

five to twenty-five years, really promotes the progress of science and the useful arts and is a benefit to the country?

In 1925 Mr. Arthur C. Fraser, of New York, then Chairman of the Section of Patent, Trade-Mark, and Copyright Law of the American Bar Association, addressed the members on the subject of Patent Law Reform in these words:

"For many years the general feeling in our profession was adverse to any suggestion for amendment of the patent laws. The idea prevailed that if we were to start something in this direction, it would be seized upon by the enemies of patent monopolies and made the occasion of legislation which would seriously injure our patent system. I long shared that opinion; but I now have reached the view that the growing evils which have become excrescences upon our patent system must be abated or the system itself will be in danger. It is better that it be amended at the instances of its friends than left to the tender mercies of its enemies."

Is it not time that the patent profession put its own house in order whether by changes in the Rules of Practice or in the Patent Statutes?

Prepared and distributed by the

PATENT SECTION OF THE GENERAL MOTORS CORPORATION.

DETROIT, MICHIGAN, May 26, 1931.

The important patents upon which Chart No. 2¹ is based

Patent No.	Name	Subject	Granted	Time pending
1, 647	Morse.....	Telegraph.....	June 20, 1840	2 yrs. 8 mo.
3, 633	Goodyear.....	Vulcanizing Rubber.....	June 15, 1844	5 mo.
4, 750	Howe.....	Sewing Machine.....	Sept. 10, 1846	11 mo.
6, 162	Corliss.....	Corliss Valve Gear.....	Mar. 10, 1849	6 mo.
9, 041	Wilson.....	Sewing Machine.....	June 15, 1852	4 mo.
11, 766	Tilghman.....	Decomposing Fat.....	Oct. 3, 1854	2 mo.
36, 163	McKay.....	McKay Stitcher.....	Aug. 12, 1862	2 mo.
36, 836	Gatling.....	Machine Gun.....	Nov. 4, 1862	2 mo.
79, 265	Sholes.....	Type-Writer.....	June 23, 1868	1 mo.
88, 929	Westinghouse.....	Air Brake.....	Apr. 13, 1869	2 mo.
105, 338	Hyatt.....	Celluloid.....	July 12, 1870	½ mo.
111, 197	Goodyear, Jr.....	Goodyear Welt.....	Jan. 24, 1871	6 mo.
124, 465	Westinghouse.....	Air Brakes.....	Mar. 5, 1872	3 mo.
127, 568	Chesebrough.....	Vaseline.....	June 4, 1872	2 yrs. 2 mo.
130, 661	Robinson.....	Electric Train Signaling.....	Aug. 20, 1872	8 mo.
138, 405	Jaunsey.....	Car Couplings.....	Apr. 29, 1873	1 mo.
157, 124	Glidden.....	Wire Fences.....	Nov. 24, 1874	1 yr. 1 mo.
174, 465	Bell.....	Telephone.....	Mar. 7, 1876	1 mo.
200, 521	Edison.....	Phonograph.....	Feb. 19, 1878	2 mo.
206, 112	Hyatt.....	Reinforced Concrete.....	July 16, 1878	1 mo.
219, 208	Brush.....	Arc Light.....	Sept. 2, 1879	3 mo.
223, 898	Edison.....	Electric Lamp.....	Jan. 27, 1880	2 mo.
224, 573	Berliner.....	Telephone Transmitter.....	Feb. 17, 1880	5 mo.
239, 659	Houston et al.....	Centrifugal Separator.....	Apr. 5, 1881	3 yrs. 5 mo.
240, 546	Reece.....	Button Hole Sewing Machine.....	Apr. 26, 1881	10 mo.
252, 576	Firman.....	Telephone Switchboard.....	Jan. 17, 1882	1 yr.
259, 054	Seely.....	Electric Flat Iron.....	June 6, 1882	6 mo.
271, 363	Ritty et al.....	Cash Register.....	Jan. 30, 1883	11 mo.
274, 290	Edison.....	Three Wire System for Distributing Electricity.....	Mar. 20, 1883	3 mo.
297, 382	Golding.....	Expanded Metal.....	Apr. 22, 1884	7 mo.
313, 849	Brown.....	Blast Furnace Charger.....	Mar. 17, 1885	1 yr. 4 mo.
341, 214	Bell et al.....	Wax Record for Phonograph.....	May 4, 1886	10 mo.
347, 140	Thomson.....	Electric welding.....	Aug. 10, 1886	4 mo.
372, 786	Berliner.....	Lateral Cut Phonograph Record.....	Nov. 8, 1887	6 mo.
332, 280	Tesla.....	Induction Motor.....	May 1, 1888	6 mo.
393, 323	Condict.....	Controller for Electric Motors.....	Nov. 20, 1888	6 mo.
400, 665	Hall.....	Production of Aluminum.....	Apr. 2, 1889	7 mo.
421, 797	Wellman.....	Open Hearth Furnace Charger.....	Feb. 18, 1890	10 mo.
424, 695	Van Depoele.....	Trolley Switch.....	Apr. 1, 1890	3 yrs.
436, 532	Mergenthaler.....	Linotype.....	Sept. 16, 1890	10 mo.
441, 831	Eastman.....	Photographic Film.....	Dec. 2, 1890	1 mo.
463, 569	Berliner.....	Telephone Transmitter.....	Nov. 17, 1891	14 yrs. 5 mo.
486, 909	Strowger.....	Automatic Telephone.....	Nov. 29, 1892	9 mo.
493, 426	Edison.....	Kinetoscope.....	Mar. 14, 1893	1 yr. 6 mo.
495, 341	Ives.....	Half Tone Process of Printing.....	Apr. 11, 1893	1 yr. 8 mo.
495, 443	Van Depoele.....	Trolley.....	Apr. 11, 1893	6 yrs. 1 mo.
536, 569	Jenkins.....	Motion Picture Machine.....	Mar. 26, 1895	4 mo.
537, 693	Malignani.....	Evacuating Incandescent Lamps.....	Apr. 16, 1895	8 mo.
549, 160	Selden.....	Automobile Drive.....	Nov. 5, 1895	16 yrs. 6 mo.
550, 288	Penhman.....	Photographic Film.....	Nov. 26, 1895	9 yrs. 8 mo.
557, 994	Lanston.....	Monotype.....	Apr. 7, 1896	5 yrs. 7 mo.
560, 291	Acheson.....	Carborundum.....	May 19, 1896	1 yr. 10 mo.
566, 968	Curtis.....	Steam Turbine.....	Sept. 1, 1896	7 mo.

¹Supra, p. 710.

The important patents upon which chart No. 2 is based—Continued

Patent No.	Name	Subject	Granted	Time pending
566, 969	Curtis.....	Steam Turbine.....	Sept. 1, 1896	7 mo.
586, 193	Marconi.....	Wireless Communication.....	July 13, 1897	7 mo.
587, 441	Knight et al.....	Street Car Controller.....	Aug. 3, 1897	5 yrs. 2 mo.
587, 442	Knight et al.....	Street Car Controller.....	Aug. 3, 1897	5 yrs. 2 mo.
589, 168	Edison.....	Motion Picture Camera.....	Aug. 31, 1897	6 yrs.
596, 923	Tirrill.....	Automatic Voltage Regulator for Dynamos.....	Jan. 4, 1898	8 mo.
610, 861	Goodwin.....	Photographic Film.....	Sept. 13, 1898	11 yrs. 4 mo.
620, 514	Tirrill.....	Voltage Regulator for Dynamos.....	Feb. 28, 1899	10 mo.
621, 195	Zeppelin.....	Airship.....	Mar. 14, 1899	1 yr. 2 mo.
643, 595	Dyer.....	Automobile Transmission.....	Feb. 13, 1900	5 mo.
652, 230	Pupin.....	Loading Coils for Long Distance Telephony.....	June 19, 1900	6 mo.
660, 066	Sprague.....	Multi-Control for Electric Trains.....	Oct. 16, 1900	2 yrs. 5 mo.
663, 777	McFeely.....	Pulling Over Machine Used in Making Shoes.....	Dec. 11, 1900	1 yr. 2 mo.
668, 269	Taylor et al.....	High Speed Steel Tools.....	Feb. 19, 1901	1 yr. 4 mo.
472, 013	Lubbers.....	Cylinder Glass Making.....	June 10, 1902	1 yr. 8 mo.
735, 304	Sangster.....	Motor Vehicle Drive.....	July 22, 1902	5 mo.
707, 791	McCurdy.....	Daylight Developing Tank for Roll Films.....	Aug. 26, 1902	2 yrs. 4 mo.
708, 553	Holland.....	Submarine.....	Sept. 9, 1902	1 yr. 1 mo.
721, 117	Wood.....	Automatic Stereotyping.....	Feb. 17, 1903	4 yrs. 11 mo.
754, 058	Fessenden.....	Radio Wave Production.....	Mar. 8, 1904	7 mo.
745, 157	Coleman.....	Electric Starter for Automobiles.....	Nov. 24, 1903	2 yrs. 9 mo.
762, 561	Seiberling et al.....	Machine for Making Automobile Tires.....	June 14, 1904	6 mo.
763, 772	Marconi.....	Wireless Telegraphy.....	June 28, 1904	3 yrs. 7 mo.
763, 768	Owens.....	Bottle Making.....	Aug. 2, 1904	1 yr. 3 mo.
776, 524	Lundquist.....	Automatic Telephone Exchange.....	Dec. 6, 1904	4 yrs. 7 mo.
775, 134	Gillette.....	Safety Razor.....	Nov. 15, 1904	2 yrs. 11 mo.
783, 168	Baker.....	Motor Vehicle Drive.....	Feb. 21, 1905	1 yr. 9 mo.
794, 086	Eastwood.....	Lifting Magnet.....	July 4, 1905	6 mo.
803, 684	Fleming.....	Two Element Vacuum Tube.....	Nov. 7, 1905	6 mo.
811, 859	Marsh.....	Electric Resistance Element.....	Feb. 6, 1906	11 mo.
821, 393	Wright Bros.....	Aeroplane.....	May 22, 1906	3 yrs. 2 mo.
836, 070	DeForest.....	Radio Tube Detector.....	Nov. 13, 1906	9 mo.
837, 616	Dunwoody.....	Crystal Detector.....	Dec. 23, 1906	8 mo.
841, 387	DeForest.....	Amplifying Radio Tube.....	Jan. 15, 1907	2 mo.
858, 383	Haefely.....	Wrapping Electrical Conductors.....	July 2, 1907	2 yrs. 9 mo.
876, 267	Colburn et al.....	Sheet Glass Making.....	Jan. 7, 1908	3 yrs.
879, 532	DeForest.....	Radio Tube with Grid.....	Feb. 18, 1908	1 yr.
885, 986	Dyer.....	Automobile Transmission.....	Apr. 28, 1908	2 yrs. 3 mo.
895, 729	Cottrell.....	Smoke and Fume Arrester.....	Aug. 11, 1908	1 yr. 1 mo.
911, 553	Edeleanu.....	Treating Petroleum.....	Feb. 2, 1909	8 mo.
942, 809	Bakeland.....	Bakelite.....	Dec. 7, 1909	2 yrs. 1 mo.
952, 467	Reynders.....	Electrical Insulator.....	Mar. 22, 1910	1 yr. 8 mo.
952, 513	Dow.....	Electrical Insulator.....	Mar. 22, 1910	2 yrs. 8 mo.
968, 136	Knighl.....	Sleeve Valve Engine.....	Aug. 23, 1910	6 yrs. 4 mo.
984, 062	Seager.....	Automobile Vacuum Tank.....	Feb. 14, 1911	3 yrs.
996, 529	Sears et al.....	System of Motor Control.....	June 27, 1911	8 mo.
1, 005, 575	Raney.....	Automotive Reclosing Circuit Breaker.....	Oct. 10, 1911	3 yrs.
1, 008, 577	Alexanderson.....	High Frequency Generator.....	Nov. 14, 1911	2 yrs. 6 mo.
1, 018, 502	Just et al.....	Tungsten Lamp.....	Feb. 27, 1912	6 yrs. 7 mo.
1, 030, 178	Hewitt.....	Mercury Vapor Lamp.....	June 18, 1912	14 yrs. 2 mo.
1, 049, 667	Burtcn.....	Oil Cracking.....	Jan. 7, 1913	6 mo.
1, 050, 728	Fessenden.....	Heterodyne Radio Circuit.....	Jan. 14, 1913	7 yrs. 5 mo.
1, 061, 770	Miller.....	Fabric Gear.....	May 13, 1913	3 yrs. 10 mo.
1, 082, 933	Coolidge.....	Tungsten Lamp.....	Dec. 30, 1913	1 yr. 6 mo.
1, 085, 443	Lanchester.....	Torsional Vibration Dampener.....	Jan. 27, 1914	3 yrs. 2 mo.
1, 090, 776	Boyce.....	Motometer.....	Mar. 17, 1914	1 yr. 2 mo.
1, 090, 991	Knighl.....	Sleeve Valve Engine.....	Mar. 24, 1914	7 yrs. 9 mo.
1, 103, 567	Cowles.....	Automobile Wheel.....	July 14, 1914	12 yrs. 10 mo.
1, 105, 974	Hoover.....	Automobile Bumper.....	Aug. 4, 1914	4 mo.
1, 113, 149	Armstrong.....	Regenerative Radio Circuit.....	Oct. 6, 1914	11 mo.
1, 114, 246	Furber.....	Thermostatically Controlled Automobile Radiator Shutters.....	Oct. 20, 1914	7 mo.
1, 128, 292	Colpitts.....	Radio Circuit.....	Feb. 16, 1915	1 yr. 1 mo.
1, 129, 520	Randall et al.....	Electrical Insulator.....	Feb. 23, 1915	4 yrs. 9 mo.
1, 132, 273	Jay.....	Vacuum Tank for Automobiles.....	Mar. 16, 1915	1 yr.
1, 160, 071	Gubelmann.....	Cash Register.....	Nov. 9, 1915	26 yrs. 4 mo.
1, 173, 079	Alexanderson.....	(Heterodyne) Radio Circuit.....	Feb. 22, 1916	2 yrs. 3 mo.
1, 180, 159	Langmuir.....	Gas Filled Incandescent Lamp.....	Apr. 18, 1916	2 yrs. 11 mo.
1, 198, 246	Lyon.....	Automobile Bumper.....	Sept. 12, 1916	3 mo.
1, 203, 190	Fritts.....	Recording Sound Photographically.....	Oct. 31, 1916	36 yrs.
1, 231, 764	Lowenstein.....	Telephone Relay.....	July 3, 1917	5 yrs. 2 mo.
1, 264, 560	Riker.....	Automobile Ignition Apparatus.....	Apr. 30, 1918	15 yrs. 9 mo.
1, 279, 471	Sperry.....	Gyroscopic Compass.....	Sept. 17, '18	7 yrs. 2 mo.
1, 308, 257	Ricketts.....	Arc Extinguisher.....	July 1, 1919	3 yrs. 4 mo.
1, 334, 533	Gubelmann.....	Cash Register.....	Mar. 23, 1920	20 yrs. 2 mo.
1, 344, 671	Bergius.....	Making Gasoline from Crude Oil.....	June 29, 1920	6 yrs. 4 mo.
1, 374, 998	Fortescue et al.....	High Tension Insulator.....	Apr. 19, 1921	3 yrs. 2 mo.
1, 396, 035	Gaisman.....	Autographic Camera.....	Nov. 8, 1921	2 mo.

The important patents upon which chart No. 2 is based—Continued

Patent No.	Name	Subject	Granted	Time pending
1, 415, 232	Ellis.....	Oil Cracking.....	May 9, 1922	8 yrs. 7 mo.
1, 429, 201	Gubelmann.....	Cash Register.....	Sept. 12, 1922	22 yrs. 8 mo.
1, 472, 583	Cady.....	Frequency Controller for Radio Sending Circuit.....	Oct. 30, 1923	2 yrs. 9 mo.
1, 507, 016	DeForest.....	Radio Signaling System.....	Sept. 2, 1924	8 yrs. 11 mo.
1, 507, 017	DeForest.....	Radio Circuit.....	Sept. 2, 1924	10 yrs. 5 mo.
1, 527, 556	Kadow.....	Glass Blowing Machinery.....	Feb. 24, 1925	14 yrs. 8 mo.
1, 527, 557	Kadow.....	Glass Blowing Machinery.....	Feb. 24, 1925	14 yrs. 8 mo.
1, 527, 558	Kadow.....	Glass Blowing Machinery.....	Feb. 24, 1925	14 yrs. 8 mo.
1, 537, 708	Schottky.....	Radio Tube.....	May 12, 1925	5 yrs. 8 mo
1, 558, 436	Langmuir.....	High Vacuum Radio Tube.....	Oct. 20, 1925	12 yrs.
1, 573, 846	T. Midgley, Jr.....	Ethyl Gas.....	Feb. 23, 1926	3 yrs. 10 mo.
1, 586, 884	Elmen.....	Alloy Used in Telegraph Cable.....	June 1, 1926	5 yrs.
1, 703, 234	Halliburton.....	Drilling Oil Wells.....	Feb. 26, 1929	8 yrs. 3 mo.

EXHIBIT No. 111

PROPOSED PATENT LEGISLATION—WHY IT IS NEEDED, THE ADVANTAGES OF THE PROPOSED LEGISLATION AND THE OBJECTIONS TO IT

[By GEORGE H. WILLITS in collaboration with a number of other members of the Michigan Patent Bar]

THE PATENT SYSTEM

The inventor tells what he has invented by filing in the Patent Office a written description of his invention, illustrated with drawings. He is also required to define in accurate language just what it is that he has invented. His definition of the invention constitutes the claims of the patent. The following statement regarding claims made by the Supreme Court in 1882 is just as true now as it was then:

"Those who have any experience in business at the Patent Office know the fact, that the constant struggle between the office and applicants for patents has reference to the claim. The patentee seeks the broadest claim he can get. The office, in behalf of the public, is obliged to resist this constant pressure."

After the patent issues, the inventor is held with more or less strictness to be limited in his monopoly to what is defined in the claims. If after taking out his patent he finds he has made a mistake in the claims he can correct it by reissuing his patent if the claims are not broad enough or by reissuing or disclaiming if the claims are too broad. However, if he wants to broaden his claim to cover constructions that did not previously come under it, he must be prompt about correcting it.

As a reward for telling the public about his invention, Congress grants the inventor the right to prevent others from using the invention for a period of seventeen years from the date of grant.

From the beginning of the patent system it was recognized that several inventors may seek patents on the same thing and Congress has provided that the Patent Office shall decide who is the first inventor and issue the patent to him. Under this authority the extremely technical and elaborate interference practice has been developed.

CONGRESS HAS ABSOLUTE AUTHORITY IN PATENT LEGISLATION

This authority is derived from the Constitution which provides that Congress has power to promote the progress of science and useful arts by securing for limited times to inventors the exclusive right to their discoveries.

Most attempts to get the Courts to correct abuses in the patent system by judicial legislation are met by statements that the matter is entirely within the control of Congress. This was exactly the position taken by the Supreme Court in the case of *Overland Company v. Packard Company*, 274 U. S., 417.

ABUSES OF THE PRESENT PATENT SYSTEM

1. *Holding applications in the Patent Office for years and years*

The inventor almost always wants to get his patent out promptly. Until he gets his patent he finds it practically impossible to get anyone to put money into the new enterprise. The inventor wants to get his patent quickly, interest capital, and supply the public with the new invention. Often he cannot get his patent out because he is tied up by interference proceedings. This cause of delay will be treated later.

Besides serving the bona fide inventor, the patent system affords excellent opportunity for those who wish merely to speculate in paper patents. This is best done by filing applications for patent on devices that you do not intend to make and sell, but that you think are in the line of future development, and then lying in wait for the inventor who combines with a complete and practical invention the energy to build and market it. Before the judicial legislation in *Miller v. Brass Company*, 104 U. S., 783, the patent speculator used to buy up issued patents and reissue them with broadened claims to cover inventions developed by others in the meantime. It is very easy to find similarities between dissimilar things if you have the two things before you and strain your imagination to find the similarities. You will recall the story of the three blind men examining the elephant. One felt his trunk and contended he was like a snake; another examined his tail and compared him to a piece of rope; and the last grasped his leg and likened him to the trunk of a tree. The blind men could not have made these claims without previous knowledge of the shape and feel of the snake, the piece of rope and the tree trunk. The patent speculator who bought a new article on the market and compared it carefully with prior patents was almost always able to find one prior patent that had sufficient farfetched similarity to the new article so that he could reissue the patent and obtain broad claims to cover the new product. The Supreme Court remarked in the above case that

"patents have been so expanded and idealized, years after their first issue, that hundreds and thousands of mechanics and manufacturers, who had just reason to suppose that the field of action was open, have been obliged to discontinue their employments, or to pay an enormous tax for continuing them."

The Supreme Court put a stop to this practice by judicial legislation. The Court held that you can't correct your patent by reissuing it with broader claims unless you apply for reissue within two years from the date of grant. This is purely court-made law. The court so ruled because Congress failed to correct the abuse by legislation.

By keeping patent applications in the Patent Office a long time the patent speculator can now do the same thing that he could formerly do by reissue. He can file great numbers of applications. He can keep them pending in the Patent Office by amending his application at the last minute, deliberately avoiding final action by the Examiner. He can then watch the market sharply for the appearance of new products, purchase samples of them, and make minute comparisons of the new products and his pending applications to find any imaginable similarities that may exist, and draw claims on those similarities. Or he may have broad claims in the application all the while, refraining from taking out the patent for any one of a number of reasons: Thus he may observe that his patent rights are being respected as it is, and see no need of securing the immediate issuance of his patent. Obviously the longer he can keep his patent pending the longer will his monopoly extend. Or he may conclude that the development is ahead of its time and lie in wait with his patent while more energetic business men create a market for it.

This is what Selden did with his patent on the use of a clutch in an automobile. In this famous case, *Columbia Motor Car Company v. C. A. Duerr and Company*, 184 Fed., 893, the court said:

"This patent was applied for in 1879 and granted in 1895. For over 16 years the application lay in the Patent Office and the applicant took full advantage of the periods of inactivity permitted by the rules and statutes. It is apparent that he delayed just as long as possible the issue of the patent to him. During this long time the automobile art made marked advances along different lines, and when, in 1895, the patent was granted, it disclosed nothing new. Others had then made the patentee's discovery and had reduced it to practice in ignorance of what he had done. While he withheld

his patent, the public learned from independent inventors all that it could teach. For the monopoly granted by his patent he had nothing to offer in return. The public gained absolutely nothing from his invention, whatever it was. From the point of view of public interest it were even better that the patent had never been granted. Judge Hough was quite within bounds in saying:

"No litigation closely resembling these cases has been shown to the court, and no instance is known to me of an idea being buried in the Patent Office while the world caught up to and passed it, and then embodied in a patent only useful for tribute."

"It is urged that we should regard unfavorably the patent on account of this delay in the Patent Office, should seek to avoid giving it a broad construction, and should permit the alleged abuse of the law to weigh against the standing of the complainants in a court of equity. But the patentee acted wholly within his rights. He merely took advantage of the delays which the law permitted him. He followed strictly the statutes and rules of procedure, and the courts cannot exact a greater measure of diligence from him. When the patent was granted under the authority of the law, it became entitled to the consideration accorded to any other patent. If the statutes and rules permit unnecessary delays, they should be changed; but we reject the view that this court owes any duty to relieve against their operation. This patent, even if it be useful only for tribute, must be viewed without prejudice and with absolute judicial impartiality."

In this clear statement of abuses the Court was wrong in one important particular. The situation was by no means unique. The case was but one example of a widespread condition. The only reason the Selden patent ever got into the Courts was because Henry Ford refused to recognize it. Otherwise the automobile industry would have quietly paid tribute. Such patents very often never reach the Courts. Their very age makes them proof against successful attack. The patents are usually of very broad scope so that loss of suit might easily result in destruction of the business man who had the hardihood to engage in it.

It is not possible to state how many industries are today under the domination of patents withheld in the secret archives of the Patent Office for long periods of years. There is no data available on this point. The following are but a few examples that happen to have come to our attention. Of these the Gubelmann patent and the Cowles patent are the only ones that have been adjudicated.

One of the most successful forms of talking motion picture is today under the domination of the Fritts patent No. 1,203,190 which was pending in the Patent Office 36 years. It was filed in 1880 and granted in 1916. If you built Fritts' apparatus today you would not have a talking motion picture machine. Fritts had only the idea of recording sound on a photographic film. To make talking motion pictures possible it was necessary that in the last 50 years Edison, DeForest, and countless other American inventors should make many important contributions to illumination, photography, electricity, radio and chemistry. Many of these other men contributed far more to the development of talking motion pictures than Fritts did but their patents have for the most part long since expired.

The calculating machine industry is today under the domination of the Gubelmann patents Nos. 1,160,071, 1,334,533, and 1,429,201 which were pending in the Patent Office 26 years, 20 years, and 22 years, respectively. It is only fair to say that Gubelmann's applications were tied up in the Patent Office by interference proceedings much against his will.

The automobile wheel industry is today under the domination of the Cowles patent No. 1,103,567, which was pending in the Patent Office 15 years.

The automobile starting, lighting and ignition industry is today under the domination of the Riker patent No. 1,264,560, and the Heany patents Nos. 1,287,988, 1,287,989, 1,301,053, 1,305,601, 1,347,460 and 1,525,129, which were pending in the Patent Office, 16, 8, 8, 9, 9, 10, and 14 years, respectively.

The steel industry is today threatened with domination by the Greene patents 1,185,394, 1,449,094, 1,449,319, 1,532,052, 1,616,796, 1,639,340, and 1,654,419, which were pending in the Patent Office 5, 7, 7, 16, 8, 14 and 5 years, respectively. These patents purport to cover the production of steel and other metals in the electric furnace.

The situation is now as bad or worse than it ever was. That it is worse is the contention of the Court of Appeals for the Seventh Circuit (at Chicago) in a decision handed down a few years ago in *Overland Motor Company v. Packard Motor Company*. The decision held the Cowles patent 1,103,567 invalid because of delays in the Patent Office. The Supreme Court overruled the Court of Appeals

holding that the present law permits these delays, and the decision was withdrawn but the following statement of the court on existing conditions remains unchallenged:

"This tendency to thus extend the monopoly period seems to be a growing one. Not how promptly may a patent be secured, but rather how long may the proceedings in the Patent Office be extended, seems to be the 'preferred' mode of procedure. And this is particularly true if the patent is to be operable in a rapidly developing art. During the pendency of the application, the inventor enjoys, to a limited extent the privileges and advantages arising from his 'Patent Applied For' notices and warnings. When demand for the article is established, he presses his application, and a patent issues. Frequently, amendments to the claims and specifications appear several years after the original application is filed, and strangely enough, these amendments particularly fit some other devices or combinations that have just appeared on the market and give promise of extensive use."

When Fritts filed his application for patent in 1880, the applicant was entitled to two years within which to answer actions by the Examiner. This period has been successively reduced until now it is six months. In spite of this change in the law the applicant who deliberately delays final action on his case and lurks in the shadows of the Patent Office ready to spring out at the unwary with his patent, is still with us. Mr. W. D. Grosbeck is Primary Examiner in charge of the division handling inventions in calculating machines. He was in charge of the division during most of the period the Gubelmann applications were in the Office. At a recent conference of patent law organizations in Cleveland a number of recommendations were made for improvements in Patent Office practice. One of these was that the Examiner should cite the best prior patents when making his first action on the case. In an article in the March 1930 issue of the Journal of the Patent Office Society, Examiner Grosbeck points out one of the difficulties in the way of doing this:

"Only one other practice approaches the above (presentation of too many claims) as an office irritant, and the two are closely allied. The second is comprehended in the sentence: 'Add the following claims,' when the examiner is beginning to hope the primary prosecution of a case is at an end. In properly prepared cases, it should be the exception, rather than the rule, that the inventor does not know at filing the limits of his invention. If he is aware of the limits, then the justifiable suspicion is that he adds claims merely to prevent issue as long as possible, in the hope of dominating some later filed application; but if such is not his purpose, the inevitable result is 'belated rejections on newly cited art,' which your agenda pretends to deplore."

Earlier in the same article Examiner Grosbeck states:

"It was a very recent experience of the writer that he was obliged to cite new art and require division on a case already pending more than nine years, because of a shift by counsel in the subject-matter of claims presented."

Attorneys thus continue to use these old, old tactics.

We have emphasized the case of deliberate holding of applications in the Patent Office because that is the most striking abuse. In a good many cases applications are kept in the Office for reasons of convenience only. Attorneys are busy. The patent business is continually growing. Incoming business usually makes it impossible to amend old cases until near the end of the statutory period allowed for reply. Often it does not matter to the client whether the patent is taken out or not. Or the case may be a difficult one and the attorney and the Examiner, through procrastination, defer giving it thorough treatment until it has been pending some years. Then there is the further advantage that many Examiners are apparently more liberal with an old case than with a new one. The Examiner has found that he cannot get the applicant to accept the lesser protection he would like to give him, and in an effort to dispose of a case that has been in his division for years the Examiner often takes a more liberal attitude and allows the applicant the protection he is seeking.

Whatever be the cause of delay, keeping an application in the Patent Office for long periods of time greatly prolongs the life of the patent, makes it impossible for the manufacturer to find out what is the prohibited field and what is not, and clogs the Patent Office so that other inventors cannot get their cases acted on.

In no other country in the world is this condition possible. In all other countries applications for patent must be prosecuted promptly. Usually the term

of the patent begins with the filing of application so that the corresponding foreign patents expire years before the United States patents.

2. Using Interference Proceedings to Prevent an Inventor from Getting His Patent

Industry moves very fast today. Plant and product become obsolete at a very rapid rate. An invention must be of very fundamental character indeed to dominate an industry until the very last year of its life. More often industry has gone to something different and better before the patent expires. Now, if it were possible to prevent an inventor from getting his patent until after the vogue of an invention had passed, a manufacturer could enjoy the business while it was good and the subsequent issuance of the patent would not affect him. Even if the invention is of more fundamental character it is quite natural for the manufacturer of an article on which another has patents pending to want to put off the day of reckoning by preventing the issuance of a patent to the inventor as long as he can.

It is possible under the present practice to prevent the issuance of a patent to the inventor by filing a patent application on the same or a similar construction and having the Patent Office set up an interference or contest between the two applicants to see which made the invention first. It is estimated on the basis of figures submitted by Commissioner Robertson that in 299 cases out of 300 the first to file patent application is the first inventor. Moreover, in only one case out of 900 does the later applicant now encounter serious trouble in getting his patent. The sole excuse for the tremendously technical and expensive interference practice is to enable the one man in 300, who has been negligent in applying for his patent, to be able to prevent anyone else from patenting the idea while securing the grant to himself. In protecting the rights of one laggard, actual or potential injustice is done to two hundred and ninety-nine diligent applicants by making it possible to use interference proceedings to prevent the issuance of their patents.

In spite of this high probability that he is not the first inventor the Patent Office shows the utmost consideration for the later applicant. Even though the later applicant, in his preliminary pleading in the interference, admits that he was not the first to make the invention, the Patent Office extends to him, as a member of the public, the right to oppose the issuance of a patent to the other party on the ground that the idea is not patentable, and on similar grounds which need not be discussed. Note the contrast in treatment here: If you, as a member of the public, write the Patent Office that a patent should not be granted John Smith because his invention is not patentable since it is shown in an old, expired patent or for any other reason, the Office will treat the protest in the rigorous fashion set out in Rule 11 of the Rules of Practice of the Patent Office and pay no attention to it. If, to prevent John Smith from getting a patent, you take the much more dubious course of filing a patent application in an attempt to patent the same or a very similar idea, the Patent Office will treat you with the utmost consideration; they will put your application in interference with Smith's application, allow you to attack his right to a patent, grant you hearings, and, if unsuccessful, permit you to appeal to the Board of Appeals and from there to the Court of Appeals, a process which, with the usual delays, may take anywhere from 3 to 5 years or more. During this period the market for the invention may have risen to a peak and dwindled to nothing. Here, as in the case of design applications, the delays and technicalities of the Patent Office are massed in formidable array against the inventor. Contested interference proceedings may cost anywhere from \$1,000 to \$30,000 or \$40,000, averaging, at a guess, from \$2,000 to \$5,000 for a hotly contested case where testimony is taken. This money must be raised by the inventor before he has obtained the patent which he needs to enlist capital in his enterprise. He is in a very difficult position.

If the inventor succeeds in getting his patent and the market for the invention has passed, he has no redress. If the invention is of fundamental character, and such inventions are very rare indeed, the losing party must stop manufacturing or stand suit. If he stops manufacturing, he nevertheless retains his past profits. If he cannot stop manufacturing and the market for the article has grown during the continuation of the interference, he may find himself in a very bad position—much worse than if he had not pursued obstructive tactics in the Patent Office.

In *Remington Cash Register Company v. National Cash Register Company*, 6 Fed. 2nd, 585, at pages 607 to 617, there is a very good description of how interferences are used to prevent patents from issuing. The inventor was prevented from getting his patents for a period of 15 or 20 years. The case, while an extreme one, is well worth reading. The court comments that:

"The whole situation presents a clear example of the abuses which are possible under the name of Patent Office procedure, and show how easily advantage may be taken of a meritorious, but impecunious, inventor, when opposed by learned counsel."

In *Thomson Spot Welder Company v. Ford Motor Company*, 268 Fed. Rep., 836, beginning at page 853, there is a very good description of how a patent monopoly may be extended by means of interference proceedings between applications owned by the same interests. This is a somewhat rarer abuse of the interference practice. The sole advantage is extension of the period of monopoly.

In fairness to the patent profession it should be stated that interference proceedings are seldom the result of deliberate filing by one person of a patent application claiming an invention he knows belongs to another.

Sometimes interferences are the result of the development of the same invention by independent inventors in different parts of the country in absolute ignorance of each other's activity. This is often possible because the inventions are of so feeble a character that anyone working in the art and encountering the difficulty is bound to make the same invention. This was especially the case when many applications were filed on accessories for automobiles. Every garageman knew that the front motor support on a well known car often broke in jolting over rough roads, and many of them filed applications for patent on brackets to repair the support. Another idea many people sought to cover by patent application was an extension to a passenger car chassis to enable it to carry long truck bodies. In one case where 30 applicants were claiming the same attachment, the Patent Office, with the wisdom of Solomon, held that if so many people could think of the same idea it could not possess the spark of genius essential to an invention.

In many other cases this situation arises: The modern engineer keeps abreast of his fellows through his engineering societies and through the efforts of salesmen and inventors to get him to adopt new devices. The things he hears about may arouse his imagination and he may conceive some other way of doing the same thing that is better and is an improvement on the construction that was brought to him. He may not make clear to his patent attorney just what it is that he has contributed. Patents occupy but a very minor place in the life of a busy engineer. The attorney prepares claims that cover not only the improvement but also the invention that was brought to the applicant. The ordinary applicant rarely understands the claims of a patent so he executes the application without reading the claims and it goes into the Patent Office with some claims in it covering the invention that was brought to him. Usually several years elapse before the Patent Office decides what claims may be allowed, and it then sets up an interference between the two applicants. By this time the events have become hazy in the engineer's memory, particularly in the case of the ordinary invention of somewhat microscopic proportions. The applicant has then forgotten just exactly what was brought to him and often not understanding what it is all about or to avoid the possibility of losing everything including some ideas that are his own, he makes affidavit as to the time he made the invention and goes into interference.

In the instance given above the applicant swore he made the invention brought to him by someone else. In many cases, under present practice, it is not necessary that he swear it is his invention. Often the applicant did not claim anything but his own when he swore to his original application. The claims that form the basis of the interference may have been put in his case after filing, and under present practice no additional oath is usually required. He need not file a sworn statement as to the time he made the invention if he does not want to. Nevertheless, he is entitled to pursue obstructive tactics and prevent the other fellow from getting his patent.

It is now proposed to require that an applicant swear he made the invention before he can go into interference but at best it is only the applicant's personal feeling about the sanctity of an oath that tends to prevent him from claiming that which he did not invent. As a practical matter perjury in Patent Office proceedings goes unpunished. We are not aware of a case within the last 10 or 15 years where the Office caused an indictment for perjury to be brought against any applicant for patent although unquestionably there were many instances of false swearing. The Patent Office decides the question which it conceives to be the only one before it; who made the invention first?

Once the interference is set up the opportunity is presented to block the issuance of a patent and the attorney seldom fails to avail himself of the opportunity if it aids his client. This is recognized practice.

The inventor who is prevented from getting his patent is just as badly off whether the opposing party has sworn truly or falsely and whether his motives are good or bad.

Last year 1,519 interferences were declared involving approximately 4,000 applications.

Many of the most important patents are held up in the Patent Office by interference proceedings. The commercial importance of inventions tied up in interference is far greater than their percentage of the total would indicate. The reason for this is a weakness of human nature pointed out by the United States Supreme Court in its decision on the famous Goodyear patent, on the vulcanization of rubber (*Providence Rubber Company v. Goodyear*, 76 U. S. Supreme Court Reports, 566):

The original patent was issued in 1844. The invention has since been covered by a succession of patents, the last of which, the reissues in question, are still unexpired and are the foundation of this litigation. The discovery was one of very great value. It is a mine of wealth to the possessors. Since the first patent was issued there have been numerous cases of litigation involving its validity. They were earnestly contested. In every instance the patent was sustained. This litigation was remarked upon by the counsel for the appellants, and it was added that this question is now, for the first time, presented to this court for consideration. It is a just commentary to say that such a litigation is always to be expected in cases like this. There are always those who are ready to gather where they have not sown. The number and ardor of the conflicts is usually in proportion to the value of the prize at stake.

EFFECT OF ABUSES ON THE INVENTOR AND ON THE MANUFACTURER

The interests of the inventor and of the manufacturer are inextricably entangled for the reason that the bona fide inventor wants to get his invention in use as soon as possible and make some money out of his patent and to do this he must either become a manufacturer himself or interest some manufacturer in it.

1. *It Is Impossible for the Inventor or Manufacturer to Find Out Whether They Can Market an Invention Without Infringing Some Prior Patent*

All applications filed in the Patent Office are kept secret. There is no statute requiring secrecy. The Commissioner has established this rule under his general authority to regulate proceedings in the Patent Office. It is probably a reasonable rule to prevent fraud if the period of secrecy is not too long. But where a patent application is concealed in the Patent Office for five or ten years or more the rule is utterly unreasonable, extending to the applicant a protection he no longer needs, and enabling him to lie in wait for the unsuspecting.

The following assumed case is not at all fanciful; this situation occurs time after time. It bears down particularly hard on the inventor and on the small manufacturer because their resources are slender. Suppose during the pendency of the Gubelmann patent an inventor developed a new calculating machine, patented it, and succeeded in interesting a manufacturer in it. Before investing his money, the manufacturer, exercising his usual prudence, had the prior patents thoroughly investigated, and found that the new machine did not infringe anyone else's patents. He thereupon contracted to pay the inventor a royalty, built his factory, bought his machinery, engaged in an extensive sales and advertising campaign, and developed a good business in the new machine. Two or three years later the Gubelmann patent comes out. The manufacturer is notified of infringement and ordered to desist manufacturing. He consults his patent attorney, is informed that the patent is valid, and that he must either stop manufacturing or take out a license under the patent if the owner sees fit to grant one. In any case the manufacturer feels he has been badly treated. He has gone ahead in good faith and taken every precaution. He has just gotten his business nicely started and now has to stop or pay a prohibitive royalty. He may be faced with financial ruin. It is not at all unlikely that some calculating machine manufacturer did find himself in precisely this position upon issuance of the Gubelmann patent.

The inventor of the improvement is as badly hurt. Either his royalties cease entirely or he is compelled to reduce the amount, for the business may not be able to stand the added burden.

Under the present system every time an inventor develops a new product and a manufacturer begins making it they must take this chance.

Patents are highly speculative things at best. A competitor may at any time run across some defense to a patent that may render it void, and the inventor and manufacturer may long before this have sunk their money into the enterprise. Because the patent monopoly is becoming a thing of fleeting character in this day of rapid obsolescence, the chance of making money out of patents is greatly reduced.

The unnecessary added hazard resulting from long pendency of applications in the Patent Office makes it harder for the inventor to sell his invention, and renders his patent less valuable because of the added risk.

2. *The Extension of the Monopoly Resulting From Long Pendency of the Application Cuts Down the Reward of the Inventor of Improvements, Retards Progress, and Handicaps the American Manufacturer in Foreign Trade*

When an industry is dominated by broad patents, the market for improvements is limited to the owners of the broad patents and those operating under them. This tends to reduce competition so that the inventor of an important improvement has a poor market for his invention.

There is a limit to the amount of royalty a new article can bear. There is almost always some competitive article not quite so cheap or good that offers competition if the price of the patented article is too high. This further reduces the reward of the inventor of improvements.

There is a natural continuous growth of the arts. The minds of the workers in a field build steadily from one new thing to the other. A patent which was long pending in the Patent Office is an anachronism. The development of the art has long since swept beyond it. With this patent outstanding there is no incentive for improvement in the art, because the improver is either entirely excluded from the field or must pay a prohibitive tribute to the owner of the patent. The manufacturer consequently avoids this field and development in it lags. Development work follows lines where no patent barrier has been set up.

The American inventor and manufacturer has always been at a disadvantage in dealing with foreign patents as compared with the foreign inventor dealing with United States patents. The United States is the only country that grants the inventor a patent without any strings on it. Every other country grants the inventor about three years of full protection such as the United States gives, and then taxes the patent year after year for the rest of its life, the amount of taxes during the life of the patent sometimes totaling several thousand dollars. More important, most foreign countries, and this includes the principal manufacturing countries, require that the inventor manufacture the new article in their country on pain of cancellation of his patent. In many cases American companies have established foreign branch factories for the sole purpose of continuing their patent monopolies abroad.

It is not possible to eliminate these handicaps. They are written into the patent laws of foreign countries. But in addition to these handicaps, the United States further and unnecessarily handicaps its own foreign trade by permitting the patent monopoly here to be extended by allowing the applicant to keep his case in the Patent Office five, ten and fifteen years before issuance. This means the patentee has a virtual monopoly for twenty-two, twenty-seven or thirty-two year, respectively, as the case may be, instead of the seventeen contemplated by Congress. The term of the foreign patent in almost every case begins with the date of filing of the application, and the longest term granted by any important foreign country is 18 years. As a result, in practically every case, American industry is paying royalty in the United States years after the patents have expired abroad. Foreign industry is rapidly learning American production methods that have protected this country against the effects of higher labor costs and patent handicaps. They are rapidly learning the advantages of high tariff against foreign made goods. With these temporary advantages wiped out, our export business is bound to be seriously affected by the handicaps imposed by our patent system. It will no longer be able to carry the burden. The inventor will suffer in that he will find the manufacturer less ready to assume the burden of the monopoly he has to sell. The burden of long pendency of patent applications is a self-imposed and unnecessary one that this country should cast off.

3. *Interference Delays*

The bad results of the long delays in issuance of patents resulting from the excessively technical interference practice have been pointed out. The delay may deprive the inventor of the entire value of his monopoly by granting him his patent after the market for the article has been exhausted, or after the article has

become obsolete. The commercial development of his invention may be held back many years because of his inability to interest anyone in his new device because of the lack of a patent to protect it. The inventor usually cannot collect royalties until his patent issues. If, while the interference is pending, the inventor does succeed in putting his invention on the market, he is forced to fight his way through the heavy expense of development and marketing the new product without any aid from the patent at the time he needs it most.

4. *Long Pending Applications Clog the Patent Office and Prevent the Inventor, Who is Really Seeking to Get His Patent Out Promptly, From Having the Prompt Service He Should Have*

Every applicant pays the same fee for his patent, and theoretically is entitled to the same service. In 1916, when the Office fees amounted to \$35, Commissioner Ewing estimated that about \$20 of that amount was spent in paying for the services of the Examiner who examines the application. With the recent increase in Office salaries, this figure may now be \$25 or \$30. The attorney in Washington making similar searches or examinations charges from \$25 to \$35 or more per day.

The applicant who keeps his case pending in the Office a long time, gets many times his \$25 worth of examination at the expense of the applicant who is really trying to get his patent out. There may be a dozen or more actions by the Office, each action hotly contested, the attorney, however, taking care to so prepare his amendments that final action by the Office is theoretically impossible. Rare is the Examiner who calls a halt to such tactics and summarily disposes of the case.

Often the Examiner has a number of applications for patent on very similar devices. If he could compel the oldest applicant to take his patent out promptly he could cite that patent against the others and force them to restrict their claims to improvements over the first patent or to drop their applications altogether. He cannot do this today for he cannot cite pending applications and he cannot make the inventor take out his patent promptly; if he attempts to do so by rigorous application of the Rules of Practice, he is met by complaints from attorneys and applicants. If he could get that first patent out, his work would be very greatly simplified.

5. *Long Pendency of Patent Applications Increases Interferences*

Today many interferences are set up between recently filed applications and applications that should have gone to patent years before. These contests, even with the present interference practice, would be avoided if patents were issued promptly. The time thus gained could be used to much better advantage in examining applications now piled up in the Office.

Another Unnecessary Handicap to the Inventor and Manufacturer

It is not possible to tell whether a United States patent is valid or not even after extensive study for insufficient information is given in the patent or application unless the case has been in interference. In most countries an invention must have been new at the time of filing application. If you can prove the invention was not new at that time you know the patent is invalid. In the United States it is sufficient if the invention was new at the time it was invented and it does not matter whether it was new or not at the time application for patent was filed, provided it had not been publicly used or sold for two years, published two years, or patented two years before in some other country. Unless a case has been in interference it is not possible to find out when the invention was made, and hence it is not possible to determine whether the invention was new at the time it was made. Many interferences are sought by one party just to find out when the other party made his invention. Taking rights under a patent often involves large sums of money, running into the hundreds of thousands and sometimes millions of dollars. The party who is urged to respect a monopoly and pay royalty or stay out of the field is entitled to know whether that patent is good or not. And to find out whether the patent is good or not it is necessary to know when the invention was made.

In buying land, the purchaser has the title searched, often as far back as the grant from the King of England. In purchasing bonds the banker secures the most complete facts about the character of the obligation and the collateral back of it. The attorney, before recommending the payment of thousands of dollars in royalty or for the purchase of patents, must study the patent and what went before it with the utmost care. He cannot rely upon a twenty-five dollar examination by the

overburdened Government Office. According to the law, the attorney must study not only the prior United States and foreign patents, which is all the Examiner searches, but he must in addition study all the prior publications and the prior work by people active in the particular field to make sure that the patentee was really the first inventor. The task placed upon the attorney is an impossible one. It can only be approximately done. When the attorney has finished his study, he must finally take a chance. And often he loses out, some prior use or prior publication turning up that he knew nothing of. The money spent for such patents must then be charged off to loss, and the attorney's reputation necessarily suffers through no fault of his own.

Every patent application should contain a statement by the inventor as to when he made his invention. The game of hide and seek which the present law provides simply increases litigation. No one is going to pay good money for a patent if he thinks the patent is invalid, and every human being, in ignorance of the time the inventor made the invention, is going to think and to hope that the inventor really did not make the invention before the date of some prior publication, or prior patent or public use that can be put in evidence. The result is another law suit.

REMEDIES THAT HAVE FAILED

* * * * *

Attempts of Patent Office to Limit Pendency of Applications

The most serious attempt to remedy this evil was made by Commissioner Thomas Ewing (1913-1918). Mr. Ewing stated in an address before the American Patent Law Association on February 28, 1916, that:

"To count on Congress for large improvement in conditions seems to me, in the light of experience, to be mere folly."

Accordingly, he attempted to accomplish the result by tightening up the administration of the Office. All cases over three years old were made special and given precedence over more recent cases. Cases over five years old had to be called to the attention of the Commissioner before the Examiner acted upon them.

In addition, Mr. Ewing secured a ruling of the Court of Appeals of the District of Columbia that, in case of dilatory prosecution, the ordinary rule that all doubts as to patentability be resolved in favor of applicant, should be reversed.

Mr. Ewing made this ruling initially in *Ex parte Pope*, 222 O. G., 1055, in which he made an example of a 15-year-old application in which the inventor tried to tie up the combination of an automobile engine and a magneto, emulating Selden's at that time successful attempt to cover up the combination of such an engine and a clutch. The Court of Appeals sustained him in 225 O. G. 739.

Mr. Ewing made the same ruling in *Ex parte Fritts*, 227 O. G. 737. This application had been pending 34 years, and covered making a sound record on a photographic strip. The application matured into the Fritts patent No. 1,203,190, previously referred to. The decision is worth reading.

First Assistant Commissioner Kinnan commented adversely on nine years pendency in *Ex parte Smart*, 363 O. G. 694 (1926).

The drive on long pending applications still continues although our experience indicates that the Commissioner's Orders on the subject are now but fitfully applied by Examiners.

Attempts By the Courts to Remedy the Evil of Long Pendency of Applications.

It has been noted that the Supreme Court recently had an excellent opportunity to legislate judicially in *Overland Motor Company v. Packard Motor Company* (274 U. S. 417), but declined to do it. The patent sued upon was pending in the Patent Office 14 years. The Supreme Court held the remedy should be sought from Congress, not from the courts.

Following the failure of the Supreme Court to sustain them in their attempt at judicial legislation in *Overland v. Packard*, the Seventh Circuit Court of Appeals paid no attention to a delay of almost fifteen years in the issuance of a patent in *Cline Company v. Kohler*, 27 Fed., 2nd, 638.

The Court of Appeals for the Second Circuit (New York), which is probably the most active circuit in patent litigation, has evidently disagreed with the Supreme Court and has applied its own remedy to long pending patents. Obviously one remedy is to hold the patents invalid for lack of invention and, personally, I think

this is sometimes done. But note the following judicial legislation in the Second Circuit:

In *Westinghouse Electric and Mfg. Company v. Jeffrey-DeWitt Insulator Company*, 22 Fed., 2nd, 277, decided in 1927, the Court held a patent void because a divisional application containing the claims was not filed until the new article had been on sale two years. This is new law. It is based on the Supreme Court's dicta in *Webster Electric Company v. Splittorf Company*, 264 U. S., 463.

In *Dwight and Lloyd Sintering Company v. Greenawalt*, 27 Fed., 2nd, 823, decided in 1928, the same rule was applied. The Court says:

"The evidence of a purpose to keep it in the Office to the last moment lawfully possible is very strong."

In this case the Court also applied the rule that a divisional case cannot be renewed except within two years of the date of allowance of the original case. This, too is new law, with the same purpose—that is, curing the abuse of long delays in the Office. The Court here comments on an interference proceeding:

"All this took nearly 7 years, and the question is whether anything was really settled."

The case is worth reading for it shows how far some courts will go in applying strict constructions of the law to patents long pending in the Office.

In *Weston Electrical Instruments Company v. Empire Electrical Instrument Company*, 136 Fed., 599, the same Court of Appeals held a patent invalid which was allowed on an application filed more than two years after the allowance of a prior application for the same invention. The Court really rewrote the law on renewals by judicial legislation.

The Third Circuit (Pa., N. J., Del.), Court of Appeals has likewise tried to apply a judicial remedy for long pendency:

In *Union Special Mach. Company v. Willcox & Gibbs Sewing Machine Company*, 32 Fed., 2nd, 924 (decided 1929), the District Court for the Eastern District of Pennsylvania applied the rule of that Circuit Court of Appeals that it would not give a broad construction to claims put in at the last minute in an obvious attempt to cover a competitor's device where no such claims were put in in the first place.

In *Victor Talking Machine Company v. Brunswick-Balke-Collender Company*, 8 Fed., 2nd, 41, decided in 1925, the Court of Appeals held that an invention was abandoned where the applicant struck out the claims and did not reinsert them in the application for four years. The lower Court said in 290 F. R. at page 575:

"Under the circumstances then existing the public interest required that Browning should not be lacking in diligence."

Browning's application was pending 14 years.

In *Hestonville, etc. v. McDuffee*, 185 Fed., 798, the Court held a patent void because its scope had been enlarged during prosecution to cover up later developments in the art. They took the position that long delayed applications should be carefully scrutinized for such departures. The delay here was 10 years.

The District Court for the Western District of Michigan, in *Wirebound Patents Company v. Saranac Corp.*, 24 Fed., 2nd, 872, held 9 years' delay in filing a divisional application to be fatal to the patent.

The trouble with attempts by the Courts to remedy these bad conditions is that because of the Supreme Court's ruling in *Overland v. Packard* they cannot seize upon mere delay in the Patent Office as a sufficient ground for holding a patent invalid. As illustrated by some of the above cited cases, the Courts do virtually legislate against particular patents by holding them invalid, not for failure to comply with particular provisions of the law as the law is written but as the law is changed or "interpreted" by the Court. This is done to prevent injustice in particular cases. But the changes in law thus made by the Courts relate to details that apply to a very few cases only. Viewed as legislation against applications long pending in the Office; the action of some of the courts in bearing down on patents which were long pending in the Patent Office is discriminatory and applies only to a few patents that happen to come before them.

SOME VERY INTERESTING PAPERS AND REPORTS ON ABUSES OF THE PATENT SYSTEM

Reference is made further on in this report to the following papers:

"The Patent Situation from the Standpoint of the Manufacturer" by Livingston Gifford.

"Patent Law Reform," by Arthur C. Fraser.

Mr. Fraser and Mr. Gifford are patent lawyers of the highest standing. They both point to delay in issuance of patents as the outstanding abuse of the system. Their analysis of the abuses of the Patent system is in harmony with the views expressed in this argument. Both of these gentlemen would undoubtedly be glad to appear before the Committee on Patents and give their opinion on this matter. Mr. Fraser's position has a good deal of support in the profession but it is rather radical, much more so than anything here proposed.

Reports of the majority and minority of the Committee on Interference Practice of the Patent Section of the American Bar Association are also referred to.

A REMEDY

The existing abuses of the Patent system may be ended in many different ways. There is now more agitation for improvement in conditions than there has been for many years.

The inventor wants to get his patent. He does not want to be subjected to the delays that result in no small part from the monopolizing of the time of the Office by dilatory prosecution of applications. He does not want to be held up in interference while his competitor enjoys the business that should be his.

The Examiner in the Patent Office would like nothing better than to call a stop to the applicant who drags his case along, year after year, and would like to devote his time to the applicant who eagerly awaits his patent.

The attorney's chief business is getting patents, not preventing their issuance. He could serve his clients better if he could get their patents out quickly and establish their monopoly while their business is young and their enthusiasm strong.

The present effort is devoted to getting action NOW on some proposals which hit at the fundamental weaknesses of the present patent system and do it in a way to secure the greatest possible amount of support from inventors, industry, the Patent Office and the Patent Bar. Prior proposals have been carefully studied and an effort has been made to find common ground among them, and to avoid extreme measures.

The problem has been approached primarily from the standpoint of the inventor who is seeking to get his patent out and his business started, and of the manufacturer who is engaged in marketing new products. However, the right of the patent profession to be as little disturbed as possible in the practice of a branch of the law that it takes years to learn has also been respected.

There are two major abuses and these abuses present two problems:

1. How to prevent the keeping of patent applications in the Patent Office an unreasonable length of time.
2. How to change interference proceedings so that they cannot be used to prevent the inventor from getting his patent.

The proposed legislation is aimed at destroying not only the abuse but also the incentive for the abuse.

It is fundamental that an applicant will not keep his application in the Patent Office an unreasonable length of time if he is penalized for so doing.

It is fundamental that if it is made practically impossible to use interference proceedings to delay the grant of a patent to the first inventor, applications will not be filed for this purpose and interferences will lose a good deal of their present popularity.

The specific proposals are as follows:

1. To get applications out of the Office: Force the applicant to take out his patent in a reasonable time by providing that the term of the patent shall not exceed the 17 years now provided nor extend beyond 20 years from the date of filing the application. This provides three years for prosecuting the application before the Examiner. It enacts into statute the three-year rule established by Commissioner Ewing in that, after 3 years, pressure is put on the applicant to get his case out.

2. To further strengthen the first provision and to assist the Office in disposing of the many old cases now on file, it is provided that when an application has been pending three years the Commissioner shall require the applicant to put the case in condition for final action or appeal within a period not less than thirty days nor more than 90 days, upon penalty of abandonment. At the expiration of that period, the Commissioner is under duty to dispose of the case within thirty days. The last provision applies pressure to the Examiner to decide the case within a time limit, and takes care of complaints, sometimes heard from attorneys, that the Examiner makes inconclusive actions and will not squarely meet the issue. With the exception of the time limit on the Examiner, this section enacts into

law Recommendation 95 of the Report made to the Secretary of Commerce in 1926 by the Committee on Patent Office Procedure.

With the last provision in effect, the public is assured that there will be no applications in the Office that have been pending more than three years and 10 months, with the exception of divisional cases, cases on appeal or in interference, or forfeited and subject to renewal. To give the public access to these excepted cases so that they may know what they can do and what they cannot do the next two changes are provided:

3. Publish cases on appeal, if they have been pending three years or more. In view of the change in interference practice to be discussed later this can do no harm to the applicant, and gives the public information it is entitled to have for the prudent conduct of its business. Publication is necessary for the convenience of the Office, attorneys and applicants, and this, of course necessitates an increase in the appeal fee.

4. Abolish renewals. Under the present statute an applicant may let a patent application lapse for failure to pay the final fee, and then bring it to life within a year by payment of a fee. This right to renew is historical only. It is little used. No one seems to know quite why the right was ever created. If renewals were not abolished a patent application could be concealed from the public a year longer, allowing it to remain in the Office a total of four years and 10 months.

5. If the applicant for patent wants to rely upon a date of invention prior to the filing of his application, he is required, before issuance of the patent, to submit an affidavit setting forth the salient facts relating to the time of invention and is thereafter bound by that statement. The dates required are those now required by the present interference practice. This information is absolutely essential in order to determine the validity of the patent and decide whether to pay royalty or stand suit.

6. To correct interference practice: Issue the patent to the first applicant. If an applicant filing later convinces the Commissioner, by sworn showing, that he, rather than the first to file, is entitled to the patent, let the Commissioner set up an interference between the patentee and the applicant according to the present practice. As previously pointed out, even now, without offering any inducement to an inventor to file promptly, in 299 cases out of 300, the first to file is the first inventor. With the inducement offered by this provision, it is to be expected that the percentage will greatly increase.

This proposal takes a middle ground between the reports of the majority and minority of a committee appointed by the Patent Section of the American Bar Association to study the interference practice. The majority favored retention of the interference practice with changes in the rules to relieve some of the worst abuses, but by no means all of them. The minority favored the entire abolition of interferences in the Patent Office and the trial of such issues in the Courts.

There follows a discussion of each of the provisions of the bill which gives in detail a catalogue of the advantages and disadvantages of each. In each case it is submitted that the advantages outweigh the disadvantages. The bill was framed after a careful consideration of all conceivable factors. It is not contended that it is a perfect solution but it is submitted that it strikes the best balance of any solution that has come to our attention, and would produce an immense improvement over present conditions. The bill is the work of no one person. It is a collection of ideas from a number of men and sources.

SECTION 1 OF THE BILL

If an application is pending in the Office three years or less the applicant receives his full seventeen years of protection. The great majority of applications are pending in the Office three years or less. If the applicant takes a longer time in prosecuting his application, the additional time is deducted from the life of his patent. For example, if four years is used in prosecuting the case, the resultant patent has a term of sixteen years. This provides an incentive for the applicant to get his case out. At present, by the opportunities offered to extend his monopoly, to add claims to his case to catch later inventors, and to secure more liberal treatment by the Office, the applicant is encouraged to keep his case in the Office as long as possible.

Very similar proposals are made in the papers of Mr. Gifford and Mr. Fraser, previously referred to.

OBJECTIONS

This section and all the rest of the bill are unnecessary. Everything will be corrected if the Office is given sufficient force.

This is penalizing the applicant with the complicated case.

With the Office a year behind this means that barely three actions will be made on the case by the Office and this is insufficient in most cases.

This provision will penalize the applicant who appeals.

ANSWERS TO OBJECTIONS

This means that the rights of inventors and of the public shall depend upon how generous Congress is with its appropriations, who is commissioner, and how fast the work comes in. It is a plea for the status quo. The bad conditions pointed out in this brief have prevailed for the past fifty years at least, under generous Congresses and under parsimonious Congresses, under able Commissioners and under inefficient Commissioners, under falling off of applications received and under increase in applications received.

The applicant with the complicated case now usually takes his full six months in replying to the office. Let him respond promptly while the mechanism is fresh in the mind of the Examiner, thereby saving the Examiner's time and expediting the case. This applicant pays the same small fee as the applicant with the simple case and gets several times the amount of service he is entitled to at the expense of the applicant with the simple case. Because he is asking and receiving special favors he should respond promptly, and completely.

Three actions are sufficient in the great bulk of cases. Recommendation 93 of the Committee on Patent Office Procedure recommends that the Office make a determined effort to conclude cases after the third action. With the passage of the pending bill to increase the force of Examiners, Commissioner Robertson predicts that within a year every case will be acted on in two months. This will make ten or fifteen actions possible in three years. The provisions of this section will then merely serve as a spur for a small minority of cases purposely delayed in the Office.

If he replies promptly and completely, the appeal can be heard and disposed of within three years in the majority of cases. Upon passage of the bill to increase the personnel on the Board, as well as the force of Examiners this will be possible in all cases which are handled promptly by the attorney. There may be delay in appeals to the Court. There is considerable support for the abolition of such appeals and with this effort we are generally in favor but are leaving this very exceptional condition for remedy by the patent profession.

OBJECTIONS—continued

This provision will penalize the applicant in interference.

If the Patent Office requires division in the third year of pendency of the application, the divisional case will suffer from insufficient time for prosecution.

There will be no certainty as to the term of a patent. One will run seven-teen years and another ten.

This will result in an applicant being compelled to take his patent out so promptly that if he is far ahead of his times he will receive no reward.

ANSWERS TO OBJECTIONS—continued

Under the present bill the patent will, in case of conflict, go to the first to file. The only thing the Commissioner can do is grant a second patent on the same thing to the later applicant who proves that he really invented the thing first. At present this situation arises in $\frac{1}{3}$ of 1% of the cases filed. By the present provision prompt filing would be encouraged and this percentage should be further reduced. Three or four years should be sufficient to dispose of the case, but if it is not, the applicant merely suffers from his own delay in filing. A dilatory minority as small as $\frac{1}{3}$ of 1% should not hold back everyone else.

The Commissioner can readily regulate the Office so that there would be no such tardy requirements of division.

It will be necessary to print on the patent the date of granting and the date of expiration. This should be on every patent now for the public does not remember how long a patent runs.

To promote science and the useful arts Congress is empowered by the Constitution to secure for *limited times* to inventors the exclusive right to their discoveries. It is discouraging to later inventors who make something practical and usable to find that it is tied up by an old patent that shows a construction that will not work. Fritts did not invent talking moving pictures; the inventors in many other fields helped much more than he did. Should his patent now dominate the work of the real, practical workers in that field, fifty years after he made his invention? Another thing, industry has so speeded up that it is a rare inventor who is more than a few years ahead of business in his field, let alone twenty years ahead

SECTION 2

This section requires that every applicant for patent, who wants to later claim he completed the invention before he filed his application, swear just when he completed it before he gets his patent. This is absolutely necessary in order to determine whether the patent is good or not under our laws.

Mr. Gifford makes the same proposal in his paper.

OBJECTIONS

This will encourage perjured testimony in the defense of patent suits, and in interferences in which the patent may become involved. Both the Patent Office and the Courts now require that parties simultaneously disclose their dates so that neither will be encouraged to commit perjury by knowing beforehand the other's dates.

ANSWERS TO OBJECTIONS

In practically every patent suit today the defendant, by order of court, finds out from the patentee before trial when he made his invention so that the same opportunity for perjury is now presented. By this time the parties have taken their stands. Had this information been available to the defendant at an earlier time compromise might have been possible.

OBJECTIONS—continued

ANSWERS TO OBJECTIONS—continued

Where the patent was in interference in the Patent Office, the public now knows the patentee's dates of invention.

In practically every other foreign country the public is apprised of the earliest date the applicant can claim. We do not understand there is any more perjury abroad than there is here.

The present practice encourages perjury in that applicants get into interference with the man they admit they got the invention from just to find out what his dates are. The average business man and attorney feel they are entitled to find this out and the interference practice is so arranged that it is not usually necessary to commit perjury to get far enough along in an interference to find out the other man's dates. Having found this out there is, of course, a temptation to stay in the interference and avail one's self of technicalities to prevent the other fellow from getting his patent. This may lead to perjury.

This provision is in line with the present trade-mark practice where the registrant is required to state when he first began using his mark. While there are many contests between parties seeking to register the same mark, there are no charges that perjury is prevalent.

It is much more difficult to build up a case of perjured testimony in connection with inventions than in the ordinary civil or criminal case. Inventions are often complicated. Anyone claiming to have made or used an invention before the patentee must be skilled in the art. In other words, the perjurer must come from a small, select group. There must be supporting physical evidence; drawings and models must be fabricated. There must be corroborating witnesses. Altogether, perjury is a difficult thing in a patent case and more of a bugaboo than a common occurrence.

Under the proposed legislation anyone who gets in interference with an issued patent is also subject to suit for infringement at the same time. His liability is increasing as the interference goes on. He is not likely to embark on an interference on flimsy evidence under these circumstances.

If the patent is an important one it will probably be necessary, and always be prudent to get this information during the course of the prosecution of the application in anticipation of use in the future. Valuable inventions are often subject to attack. All this section requires is that the applicant publish that which he has usually gathered together even now before his patent issues.

It will be difficult to get this information from the inventor three years or so after the case is filed.

SECTIONS 3 AND 5

When an invention has been before the Office by application for patent for three years, the Commissioner shall re-examine the application and require the applicant, on pain of abandonment, to place the case in condition for issuance of patent thereon or for appeal within a period not less than thirty days nor more than ninety days, to be set by the Commissioner. In handling old cases now, the Commissioner is compelled to coax and entreat the applicant to get his case out. These sections give the Commissioner a club to compel closing up of old cases in the interest of other inventors and of the public. At the expiration of the period set, the Commissioner is given thirty days in which to take final action on the application. It is necessary to make this duty mandatory on the Commissioner for the reason that according to Section 1, the term of the patent which may be granted applicant is being shortened day by day. The Examiner must be compelled to decide promptly. It is not enough to penalize the applicant for keeping his case in the Office. It is essential that the case be patented within a reasonable time so the other inventors and the public may know what they can do and what they cannot do.

This proposal is substantially the same as Recommendation 95 of the Committee on Patent Office Procedure that reported to the then Secretary of Commerce Hoover in 1926.

OBJECTIONS

The Office often does not find the best reference until the case is several years old, and the real prosecution of the case begins at that time. The time for prosecution is then unreasonably shortened.

What about the applicant in interference?

A divisional or continuing application filed in the Patent Office after the parent case has been pending three years becomes subject immediately to this provision and insufficient time is given for adequate examination.

ANSWERS TO OBJECTIONS

The duty of prompt and efficient examination lies squarely on the Office. The correction of poor examination necessarily lies in the hands of the Office. The Commissioner has adopted the policy of appointing supervisors to see that the best references are cited in the first actions.

The Office now unnecessarily prolongs the pendency of patent applications by refusing to act on them while the interference is going on. It will be necessary for the Office to continue the prosecution of such applications concurrently with the carrying on of the interference. Otherwise the period of the monopoly of the applicant will be cut down unnecessarily.

In such cases the Commissioner must examine the case immediately and the applicant has ninety days in which to reach some conclusion with the Examiner. This is a liberal allowance of time for the dilatory applicant. If divisional cases are not thus tied down to the time of filing of the original case the present abuse will continue but in slightly different garb; as in *Packard v. Overland*, the applicant will file continuing applications in the last days of prosecution and keep his case concealed in the Office. Other inventors and the public will continue to be in a haze of uncertainty. In practically all other countries continuing applications go back to the date of the original. Article 4 of the Convention for Protection of Industrial Property signed at The Hague on November 6, 1925, provides that divisional applications go back to the date of the original application.

OBJECTIONS—continued

The Office should not be required to dispose of a case within a time limit. Suppose after expiration of the period they find a new reference that renders the patent invalid?

ANSWERS TO OBJECTIONS—continued

It is not possible to secure anything but a sketchy examination of a patent application for the \$25 the Office has to spend whether the work is done by the Office or by outside attorneys. For a fairly thorough examination \$300 or \$400 is a reasonable figure. The Office now often fails to find the best reference. Absolute anticipations are rather rare. Frequently a better reference is now found by the Examiner after the case has been allowed and before patenting. In most cases the application is allowed to go to patent for the Office rightly feels that there must be an end to the prosecution of applications some time. Under this change in the law the Office need but continue its present practice.

SECTION 4

By this section renewal of patent applications is abolished. After the Commissioner has advised an applicant he may have his patent upon paying the final fee, the applicant has six months to pay it in. If he does not pay it within that time, the applicant may, upon payment of an additional fee within the next year, have the case reopened and reexamined. Often the reexamination is but formal and the Commissioner again notifies the applicant he may have his patent if he pays the final fee, and the applicant has six months more to pay it. The right of renewal, whatever may have been its original purpose, actually functions merely as another way to keep a case pending in the Patent Office.

OBJECTIONS

Then if an applicant fails to pay his final fee within the six months allowed, his case is dead, for the Commissioner has no right to revive it.

If an applicant fails to properly claim his invention before the first allowance, his only remedy is by reissue and this may make it impossible for him to recover against those who have in the meantime used his invention.

Then by simply filing continuing application after continuing application at six month intervals an applicant can keep his case in the Patent Office indefinitely.

ANSWERS TO OBJECTIONS

Six months is plenty of time within which to decide whether an invention is worth spending \$25 more on. In most cases if the fee is not paid, the applicant can file another application and merely loses the right to go back to the date of filing of the first application as the date of completion of his invention, or "reduction to practice" as it is called. This is no more than a proper penalty for tardiness.

If his application has been pending in the Office three years, he has had plenty of time to find out what his invention is. If it has not been pending three years, the applicant may file a continuing application after the allowance of the first, and prosecute it the same as he did the original; if three years have elapsed since the first case was filed, then by filing a continuing application the applicant has, under Section 5, from 30 to 90 days to correct his claims. In addition, he may reissue the day the patent is granted if he sees fit.

That is true, but his monopoly is expiring, and he is paying for the privilege of lying in wait by being compelled to file a new case each time and pay a new fee. It would really be better if a positive stop were erected here also but this would mean added complication.

SECTION 6

This section eliminates interferences between applicants, the patent being granted to the first to file. In 99 $\frac{3}{4}$ % of the cases the first to file is the first inventor. If the later applicant can satisfy the Commissioner by prima facie showing under oath that he made the invention before the first to file, the Commissioner conducts interference proceedings as at present to see if a second patent for the same invention should be granted the later applicant.

Mr. Arthur C. Fraser's paper and the minority report of the Bar Association Committee on Interference Revision go much further than this proposal, and recommend abolition of interferences in the Patent Office. This would make the granting of additional patents to other inventors for the same invention a mechanical act, and take away the judicial function of the Office. There is much support for this change. The present proposal is an attempt at compromise.

OBJECTIONS

This will be hard on the applicant who is unavoidably late in filing his case. The patentee will be able to prevent the applicant from getting his patent for a long time by dilly-dallying with the interference.

The American patent system has from its very beginning been conducted on the theory that the patent should be granted the first inventor. This should not be lightly overturned.

This is not necessary. Just improve the present practice.

ANSWERS TO OBJECTIONS

It is estimated that in only $\frac{1}{4}$ of 1% of the cases is the later applicant the first inventor. This section is hence much more efficient in giving substantial justice than any other legal proceeding with which we are acquainted.

The dilatory applicant is the one who should suffer for his delays. By the present system it is the prompt and enterprising inventor who is made to suffer for fear of injuring some laggard.

In interferences with patents many of the time-killing motions may not now be brought. This results in shortening the contest. Further improvement can be made by following the recommendations of the majority of the Bar Association Committee on Revision of Interference Practice.

At the beginning of the Patent system an interference was decided informally by arbitration by a Board of three men. There were no appeals, and presumably the delays were slight. Now the interference practice is so cluttered and obscured by technicalities that it does not function satisfactorily.

The present practice is the result of almost 150 years of evolution. The flower of the practice is the famous Gubelmann case in which the inventor was held up in the Patent Office 22 years. This amply demonstrates that a positive stop must be raised. Without such stop the same pressure that created the present practice will soon mold the "reformed" practice into the old distorted shape.

OBJECTIONS—continued

This provision will tend to cause inventors to run into the Patent Office with half-baked developments instead of encouraging them to really have something usable before they apply for patent.

This would result in many patents being issued for the same thing.

This would increase suits under 4912 to cancel patents where two have been issued on the same invention. Litigation would thus be increased in the now over-burdened Federal Courts.

ANSWERS TO OBJECTIONS—continued

A great many inventors now run into the Office with half-baked devices, even perpetual motion machines, and no way has been found to stop them. It is a rare inventor now that delays filling his application. The inventor almost always fears someone is going to steal his invention, and so files promptly. On the other hand, many progressive business concerns that have established departments to consider new devices submitted to them, make it a rule to recommend that the inventors file their patent applications before submitting their ideas, to avoid any misunderstanding at a later date as to what was submitted. It is good to encourage promptly filing.

In England and most foreign countries inventors are under much greater compulsion to file promptly. The first to file gets the patent. If the inventor before filing describes his invention in a lecture or publication, he is barred from getting a patent. Yet these foreign countries seem to be no more bothered by premature filing of applications than we are.

That is the case now. Every week patents are issued that should not have been issued, and, later, patents on the same inventions are issued to others after interference proceedings. By stimulating prompt filing by the first inventor there should be less accidental improper granting of patents than now.

This remedy is rarely used and there are plenty of patents now issued for identical inventions. The reason is that the better remedy is suit for infringement. Usually the party holding one of the patents knows that the other is the first inventor and does nothing with his patent, so it does not pay the first inventor to bother with him.

SECTION 7

The changes in this section permit the applicant to appeal after one rejection. This is necessary to make Section 5 workable for it may sometimes be necessary for the Commissioner, in his thirty days, to take final action on some point that, technically, has been only once considered. Even though the applicant does take his appeal after a first rejection, the Examiner can still write the applicant and suggest compromise after the appeal has been taken.

The important provision is for the publication of appeals after a case has been pending three years. The purpose of this is to let the public know within a reasonable time after a patent application has been filed, what they are forbidden to do. By publishing the cases they will be available to the Patent Office to reject other later filed cases on.

OBJECTIONS

This is a breach of the policy of keeping applications secret in the Patent Office and exposes the applicant to attack by unscrupulous persons.

ANSWERS TO OBJECTIONS

In view of the fact that the patent is issued to the first to file, by virtue of section 6 of the bill, there is nothing that any member of the public can do to prevent the grant of a patent to the applicant whose case is on appeal, except to file a reissue application and demand an interference. This contingency is very remote.

The applicant has 3 years of secrecy, and at the end of that time the public interest demands that he no longer be permitted to conceal his application in the Patent Office.

THE FULL TEXT OF THE BILL

A BILL amending Sections 4884, 4894, 4903, 4904, 4909, 4934, and to repeal Section 4897 of the acts relating to letters patent for inventions.

Be it enacted by the Senate and House of Representatives of the United States of America in Congress assembled, That Section 4884 of the Revised Statutes of the United States be amended to read as follows:

"Section 4884. Every patent shall contain a short title or description of the invention or discovery, correctly indicating its nature and design, and a grant to the patentee, his heirs or assigns, of the exclusive right to make, use, and vend the invention or discovery throughout the United States and the Territories thereof, referring to the specification for the particulars thereof. The term of such patent shall begin with the issuance thereof and shall terminate at a date not more than twenty years from the date of filing by the applicant in the United States Patent Office of his earliest application disclosing the invention covered by any of the claims of said patent; but in no case shall such term be more than seventeen years. A copy of the specification and drawings shall be annexed to the patent and be a part thereof."

SECTION 2. That Section 4892 of the Revised Statutes of the United States be amended by adding at the end thereof the following

"Before issuance of a patent the applicant may file a statement, under oath, setting forth the dates of his

(a) Original conception of the invention defined in the claims finally allowed.

(b) Completion of the first drawing of said invention.

(c) Making the first written description of said invention.

(d) First disclosure of said invention to others.

(e) Reduction to practice of said invention.

"In suits for infringement of a patent the patentee shall be restricted to dates not earlier than those set up in such statement. If an earlier date be proven such proof shall be held to establish the date alleged in the statement and none other. If no statement shall have been filed, his date of invention shall be conclusively presumed to be the date of filing the first patent application effective as a constructive reduction to practice of the invention in issue in the United States."

SECTION 3. That Section 4894 of the Revised Statutes of the United States be amended to change the phrase "of which notice shall have been given to the applicant;" to read as follows: "or upon failure of the applicant to place his application in condition for issuance of patent thereon, or for appeal, within a time limit set by the commissioner in accordance with Section 4903 of the Revised Statutes of the United States as amended, of which action notice shall have been given to the applicant."

SECTION 4. That Section 4897 of the Revised Statutes of the United States be, and the same is hereby, repealed.

SECTION 5. That Section 4903 of the Revised Statutes of the United States be amended to read as follows:

"Section 4903. Whenever, on examination, any claim for a patent is rejected, the commissioner shall notify the applicant thereof, giving him briefly the reasons for such rejection, together with such information and references as may be useful in judging of the propriety of renewing his application or of altering his specification; and if, after receiving such notice, the applicant persists in his claim for a patent, with or without altering his specifications, the commissioner shall order a re-examination of the case: Provided, however, whenever any application for

patent has been pending three years, or claims an invention disclosed in an application by the same inventor which has been on file in the Patent Office three years or more, the commissioner shall order a re-examination of the application and shall require the applicant to place his application in condition for issuance of patent thereon, or for appeal, within a period, not less than thirty days nor more than ninety days, to be set by the commissioner. And it shall be the duty of the commissioner within thirty days after the expiration of said period to take final action on said application."

SECTION 6. That Section 4904 of the Revised Statutes of the United States be amended to read as follows:

"Section 4904. Whenever an application is made for a patent which, in the opinion of the commissioner, would interfere with any pending application, he shall issue a patent to the interfering applicant who was the first to file an application disclosing the common invention, provided said applicant is entitled to rely upon the filing of said application as a constructive reduction to practice of the invention; and he shall reject the other application or applications on the patent thus issued. Should an applicant claim to be the first inventor of an invention claimed in a patent issued to another on a previously filed application and establish to the satisfaction of the commissioner by prima facie showing under oath that he made the invention before the date of filing of the earliest application on which the patentee is entitled to rely as a constructive reduction to practice of the invention, the commissioner shall direct the examiner in charge of interferences to proceed to determine the question of priority of invention. And the commissioner may issue a patent to the applicant if adjudged the prior inventor, unless an adverse party appeals from the decision of the examiner in charge of interferences, within such time, not less than twenty days, as the commissioner shall prescribe.

SECTION 7. That Section 4909 of the Revised Statutes of the United States be amended to read as follows:

"Section 4909. Every applicant for patent or for the reissue of a patent, any of the claims of which have been rejected, and every party to an interference, may appeal from the decision of the primary examiner, or of the examiner in charge of interferences in such case, to the Board of Appeals; having once paid the fee for such appeal. In the case of an application for patent which has been pending three years or more or claims an invention disclosed in an application by the same inventor which has been on file in the Patent Office for three years or more, the commissioner shall, upon payment of the appeal fee, proceed forthwith to have the said application with all of the claims thereof published with a notation that the case is on appeal, and the said application and all proceedings relating thereto shall thereafter be thrown open to public inspection. Where the application, at the time of appeal, does not have an effective filing date more than three years old, it shall, upon attaining said age, be forthwith published as in the case of issued patents and thrown open to public inspection.

SECTION 8. That Section 4934 of the Revised Statutes of the United States be amended by striking out the following words:

"On an appeal for the first time from the primary examiners to the Board of Appeals, \$15.

"On every appeal from the Examiner of Interferences to the Board of Appeals, \$25."

and substituting therefor the words:

"On an appeal for the first time from the primary examiners to the Board of Appeals, \$40.

"On every appeal from the examiner of interferences to the Board of Appeals, \$50."

SECTION 9. Section 1 hereof shall take effect upon approval of this act but shall apply only to applications thereafter filed; Sections 2, 3, and 5 hereof shall take effect one year after approval of this act; Section 4 hereof shall take effect upon approval of this act but with respect to applications then forfeited or renewed there are reserved to the applicants or other parties at interest the right to revive the applications, if forfeited, and the right to prosecute the renewed applications the same as if this section had not been enacted into law, except that such renewed applications shall be subject to the remaining provisions of this act; Section 6 shall take effect upon approval of this act, but shall not apply to interferences then pending; Sections 7 and 8 shall take effect ninety days after approval of this act but shall not apply to cases then on appeal.

EXHIBIT No. 112

THE MANUFACTURE OF BOTTLES

[Prepared by the Department of Justice for the use of the Temporary National Economic Committee]

MEMBERS OF THE COMMITTEE

- JOSEPH C. O'MAHONEY, Senator from Wyoming, Chairman.
 HATON W. SUMNERS, Representative from Texas, Vice Chairman.
 THURMAN W. ARNOLD, Assistant Attorney General.
 *WENDELL BERGE, Special Assistant to the Attorney General.
 Representing the Department of Justice.
 WILLIAM E. BORAH, Senator from Idaho.
 WILLIAM O. DOUGLAS, Chairman.
 *JEROME N. FRANK, Commissioner.
 Representing the Securities and Exchange Commission.
 EDWARD C. EICHER, Representative from Iowa.
 GARLAND S. FERGUSON, Chairman.
 *EWIN L. DAVIS, Commissioner.
 Representing the Federal Trade Commission.
 WILLIAM H. KING, Senator from Utah.
 ISADOR LUBIN, Commissioner of Labor Statistics.
 *A. FORD HINRICH, Chief Economist, Bureau of Labor Statistics.
 Representing the Department of Labor.
 HERMAN OLIPHANT, General Counsel.
 *CHRISTIAN JOY PEOPLES, Director of Procurement.
 Representing the Department of the Treasury.
 RICHARD C. PATTERSON, Jr., Assistant Secretary.
 Representing the Department of Commerce.
 B. CARROLL REECE, Representative from Tennessee.
 LEON HENDERSON, *Executive Secretary.*

* Alternates.

THE MANUFACTURE OF BOTTLES

Preliminary Statement.—This statement has been prepared by the Department of Justice for use in connection with its study of patent practices in the glass container industry. It contains (1) a description of the process of manufacturing glass containers and (2) certain general economic facts with respect to the glass-container industry in the United States.

The testimony which it is expected will be elicited in the hearings before the Committee will, in many instances, relate to the various steps in the process of manufacturing glass containers and will involve the use of terms peculiar to the technology of that process. It is believed that the explanation of the process of manufacture and the diagrams and pictures contained herein may be of material assistance in following the testimony.

Process of Manufacture.—Until the turn of the century, bottles and other glass containers were made exclusively by hand—a process which was one of the most highly skilled manual arts employed in large-scale industrial production. In the first step of the hand-blown process, the glass blower dipped the end of his PONTIL, sometimes called the "PUNTY" (a five-foot hollow steel tube), into a tank of molten glass (Fig. 1). Rapidly revolving the pontil, he gathered a mass or GOB of molten glass on its end, withdrew it from the furnace, and blew through the tube, thus forming an enlarging bubble. By swinging, twirling, and rolling the bulbous mass on a MARVER, or flat slab, the glass was worked into a hollow, pear-shaped form, hanging in suspension from the pontil. This partly shaped mass then was lowered into a hinged iron MOLD, which was closed around it, and the glass was blown up to its completed shape within the mold.



FIGURE 1.—Glass blower at work. Illustrates bottle-making methods prior to 1905.

The transition from this age-old handblown art to automatic machine methods was quite sudden. About 1905 MICHAEL J. OWENS, a glass-blower, had developed a successful and fully automatic machine for blowing bottles (Fig. 2). It could produce more than 30,000 bottles every 24 hours as compared with the six or eight hundred which a skilled handblower could turn out in an exhausting day's work.

For the common varieties of glass containers the principal raw materials are sand, soda ash, and limestone, though broken glass, called CULLET, generally is added to the mixture. These materials are melted in a FURNACE or TANK (Fig. 3). The mixture of raw materials is fed into the hottest, or melting, portion of the furnace, flows slowly into a cooler section of the furnace, and thence by way of a channel to the place from which it will be fed to the bottle-making machine.

The Owens machine (see Fig. 2) employs the so-called SUCTION PROCESS. Molten glass flows from the cooler section of the tank into a shallow REVOLVING POT. Iron molds mounted on arms radiating from a central pillar revolve so that each mold, during a part of its revolution, passes over the revolving pot. At this point the mold lowers itself until the open end touches the pool of molten glass, sucks up a CHARGE of glass, rises and moves on. As it rises, a knife slides across the bottom of the mold, closing it and cutting the glass off from that in the pool. The upper part of the cavity in the mold contains a PLUG against which the charge has been forced, thus forming the opening which later becomes the neck of the bottle (Fig. 4). In this manner the charge of glass has been shaped into a preliminary form known as the PARISON, which roughly approximates the shape of the finished bottle. This mold, termed the PARISON MOLD, then divides and withdraws and another mold, called the FINISHING MOLD, comes into place around the parison or embryo bottle which is hanging by its lip or neck. Thereupon the parison is blown into its completed shape within the finishing mold (Fig. 5). At this point in its revolution the arm passes over a CONVEYOR on which the bottle is deposited. The parison mold then swings back into operating position, to dip into the pool of molten glass once more. The machine may consist of from six to sixteen arms depending upon the type of ware to be produced and the speed of operation desired.

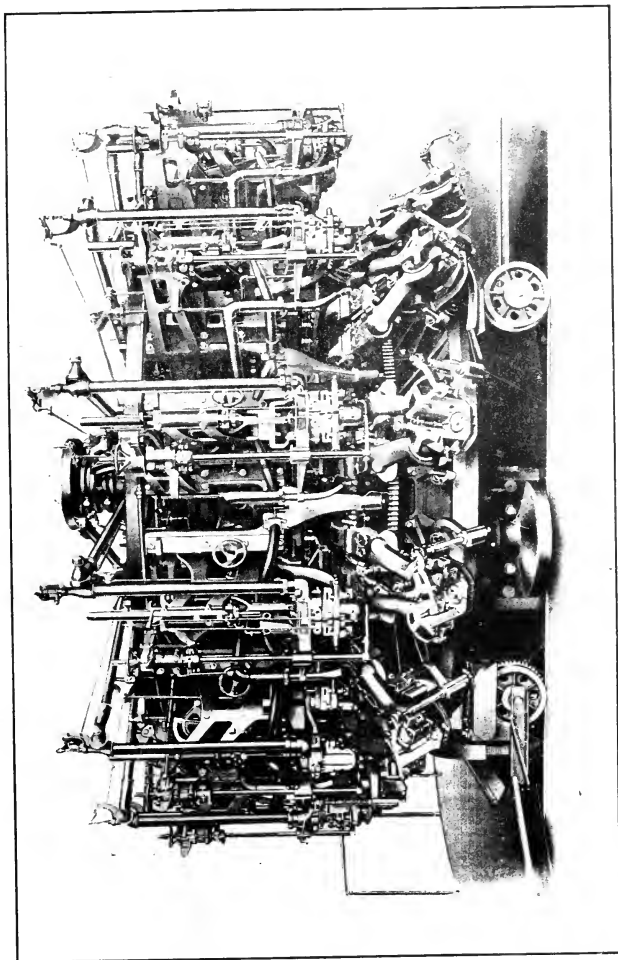

FIGURE 2.—Owens bottle machine, a fully automatic machine successfully operated in 1905.

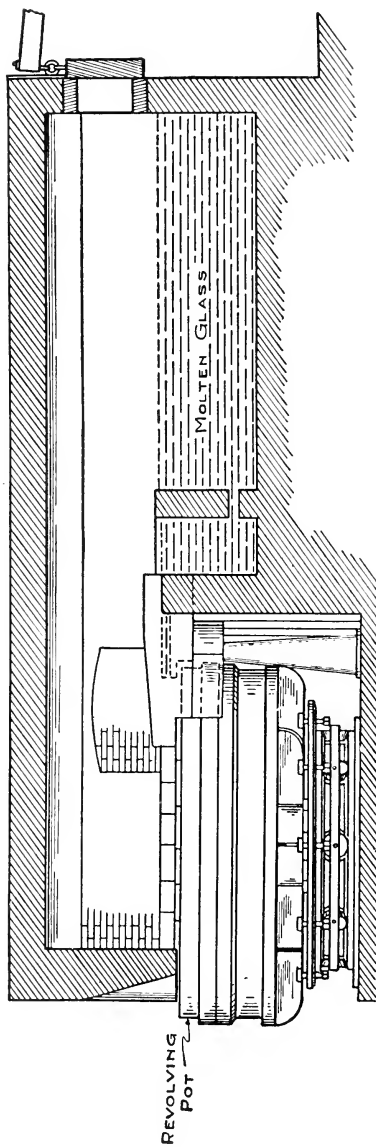

FIGURE 3.—Glass tank or furnace with revolving pot, for melting and delivering glass to the Owens bottle machine.

ACTION OF OWENS MACHINE
IN FILLING MOLD BY SUCTION

FIGURE 4.—Action of Owens machine in filling mold by suction from the revolving pot.

Since 1917 the so-called **GOB-FED PROCESS** for the automatic production of glass containers has been used in competition with the Owens suction method. The gob-fed process requires a **FOREHEARTH**—a covered channel conducting the molten glass from the tank to the device which feeds the charge of glass to the molds. Equipment for the process consists essentially of two separate mechanisms: a **FEEDER** for introducing molten glass into the molds, and a **FORMING MACHINE** for shaping the bottle. Molten glass is fed from a hole or **ORIFICE** in the bottom of the forehearth by a mechanism which causes the molten glass to be extruded in gobs, or separate drops, with a shape roughly approximating that of the molds into which they will drop. In some types of feeders (Hartford "Single Feeder") a **RECIPROCATING PLUNGER** or **NEEDLE** operates over the orifice to control the quantity and shape of the extruded gob. Just beneath the orifice is arranged a pair of **SHEARS** which is operated in timed relation to the movement of the plunger so that it cuts off the suspended gob at the desired point in the cycle (Figs. 6 and 7). In some types of plunger feeders the shape of the gob is controlled by adjustments in the operation and timing of the plunger and shears. In those types of feeders known as **AIR FEEDERS** (Stuckey, Shawkee, et al) control over the extrusion of glass from the orifice is obtained through the use of an alternate air pressure and vacuum effect rather than by a plunger.

The forming operations in the gob-fed process are similar to the same operations in the suction process, although there are many variations in the mechanics employed. In some machines (Lynch, O'Neill) the parison and finishing molds are mounted on separate revolving systems or tables with the parison being transferred from one set of revolving molds to the adjacent revolving set, by automatic means. This is the so-called **TWO TABLE MACHINE** (Figs. 8 and 9). In another type of machine (Hartford) a row of parison molds is in fixed position on a rectangular table (Fig. 10). The molds receive gobs distributed to them in turn from the feeder chutes or **DELIVERY TROUGHS**. After the parisons have been formed in these molds by an initial blowing operation they are swung in an arc and deposited in the finishing molds located on the other side of the table. The final blowing operation is accomplished in the second set of molds and the finished bottle is placed upon a conveyor by means of an **AUTOMATIC TAKE-OUT**.

BLOW AND BLOW PROCESS

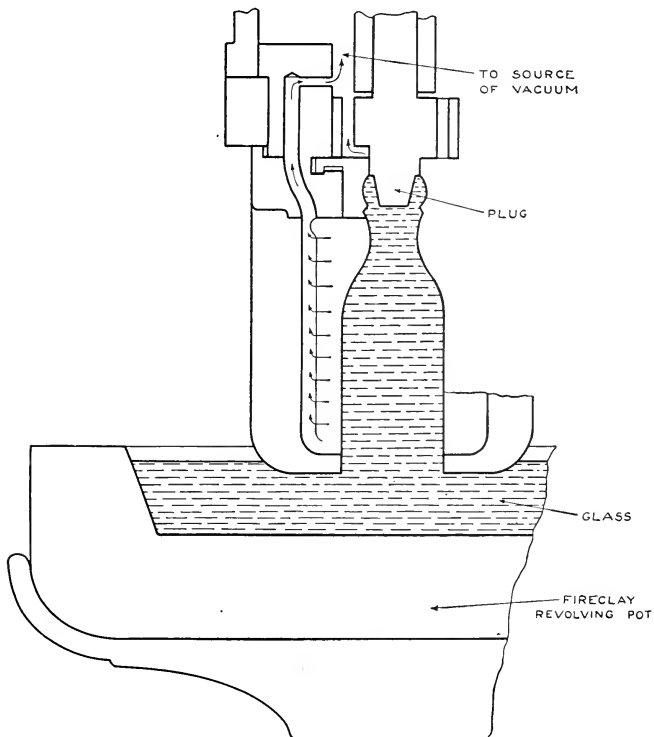
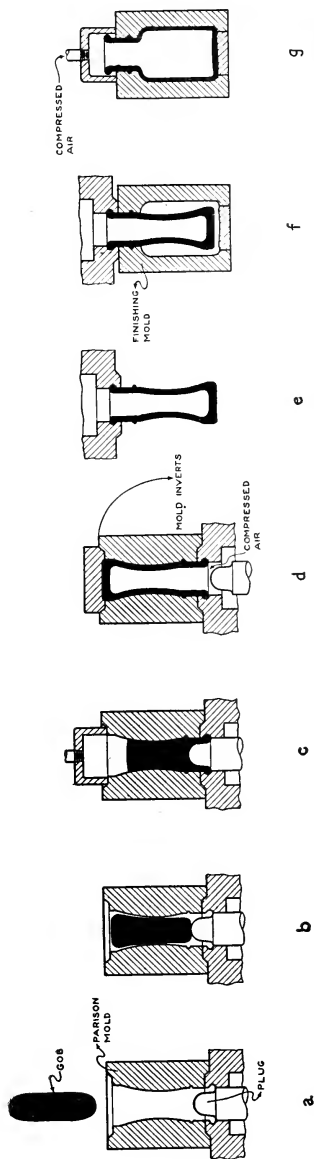

FIGURE 5.—Process of forming a bottle. In the Owens machine the mold is filled by suction and two successive "blow" operations (similar to those shown at d, e, f, and g) form the bottle. In a competitive method, called the gob-fed process, glass is dropped into the molds in gobs, as shown in operations a, b, and c.

ACTION OF HARTFORD SINGLE FEEDER

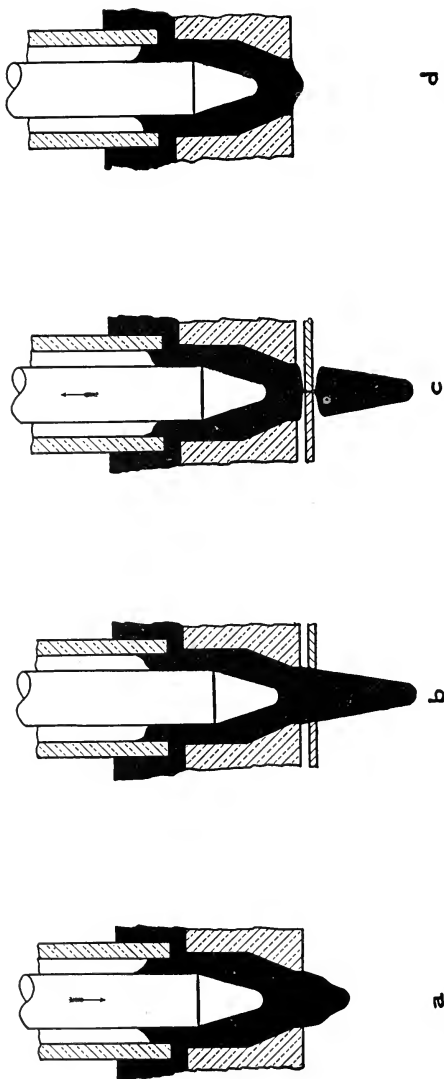

FIGURE 6.—Diagram of operation of feeder, which delivers gobs of glass from the tank to the molds of the forming machine, in the gob fed process.

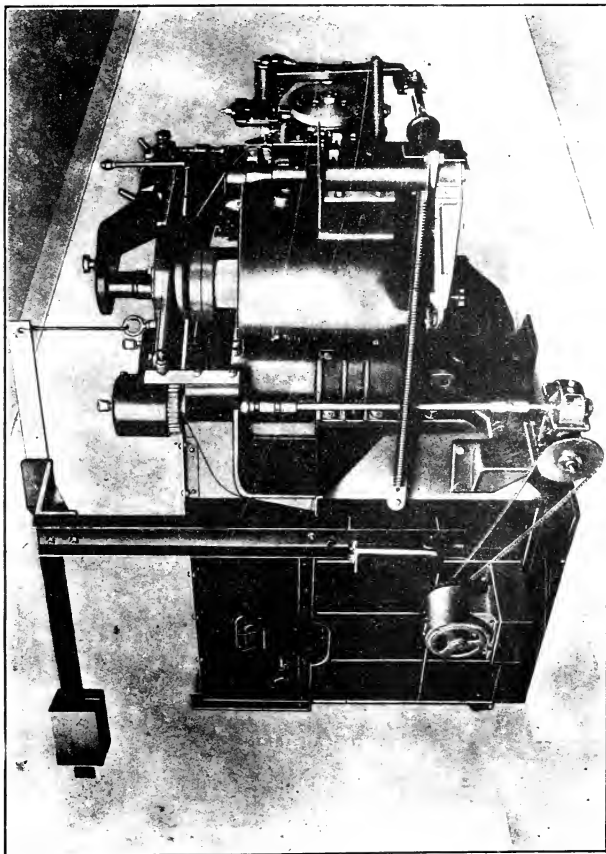

FIGURE 7.—Hartford "single feeder."

For NARROW-NECK containers the so-called BLOW AND BLOW process generally is employed (See Fig. 5) in which compressed air is used in each of the blowing operations. For machines used to make WIDE-MOUTH ware (Miller) the so-called PRESS AND BLOW method generally is employed (Fig. 11). In this process the first blowing operation is supplanted by a "pressing" operation in which a plunger is used to form the cavity in the parison (Fig. 12). Many articles, such as tumblers and dishes, are made by a PRESSING operation alone (Hartford and Miller). This method uses a plunger to perform the entire operation of forming (Fig. 13).

The completed bottles are carried by the conveyor into a LEHR or oven (Fig. 14), where they are STACKED, or arranged in closely spaced rows, on a belt which moves slowly through a long chamber or tunnel. The temperature of the bottle is lowered slowly in this oven so that internal strains in the bottle are relieved. This process of ANNEALING tends to prevent the finished product from cracking or breaking when subjected to sudden jars or rapid changes in temperature.

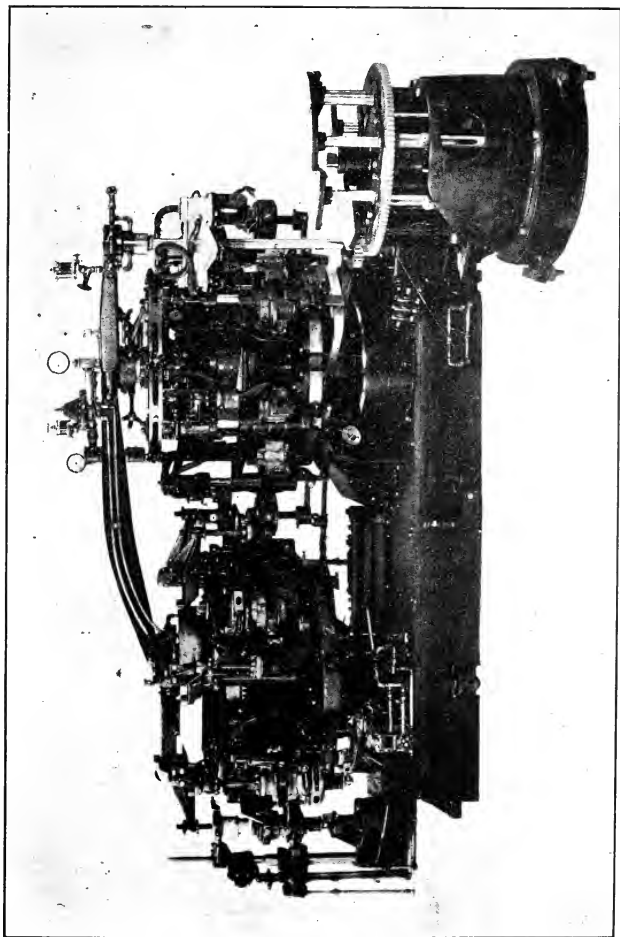

FIGURE 8.—Lynch "10" (forming) machine.

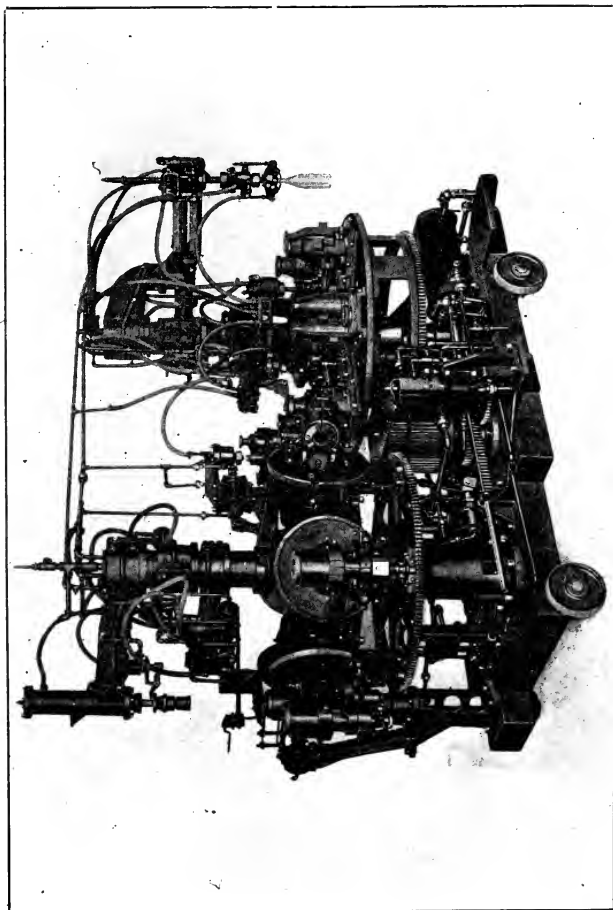

FIGURE 9 —O'Neil (forming) machine.

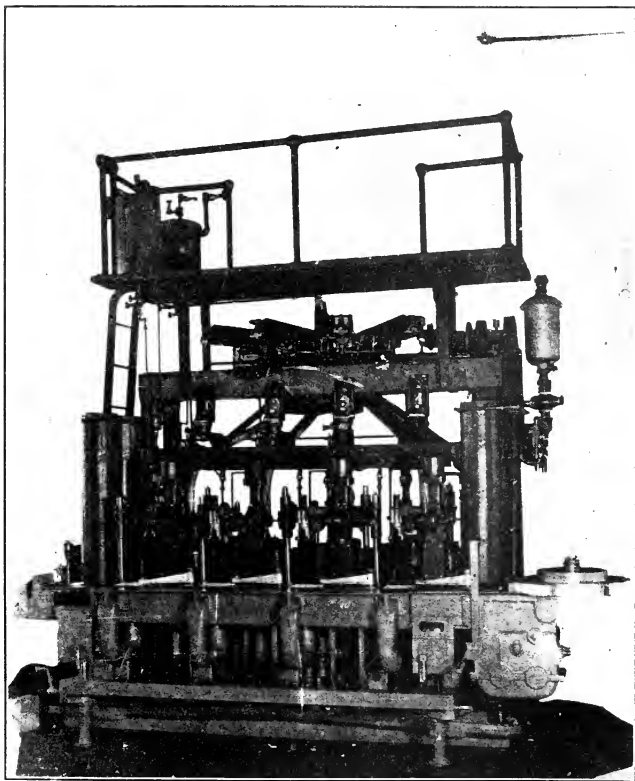

FIGURE 10.—Hartford "IS" (forming) machine.

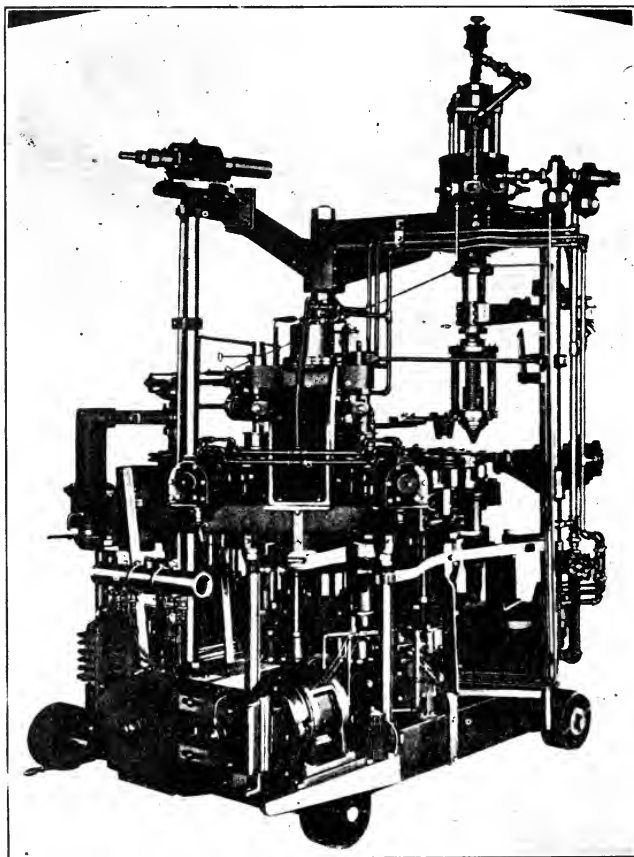

FIGURE 11.—Miller "JPM" (forming) machine.

PRESS AND BLOW PROCESS

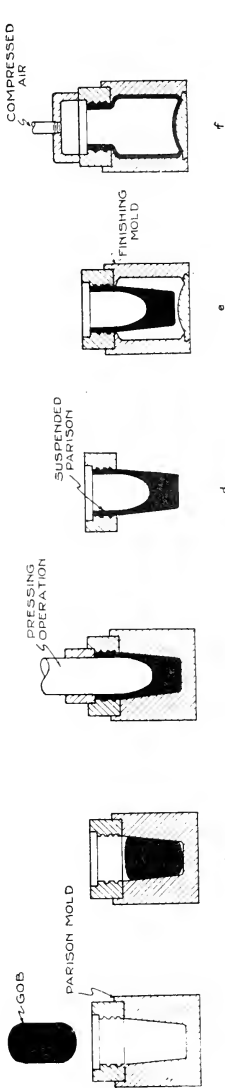

FIGURE 12.—Press and blow method of forming a bottle. This process is distinguished from the blow and blow method by the substitution of a pressing operation (at c) for the first blowing operation (at d in Figure 5).

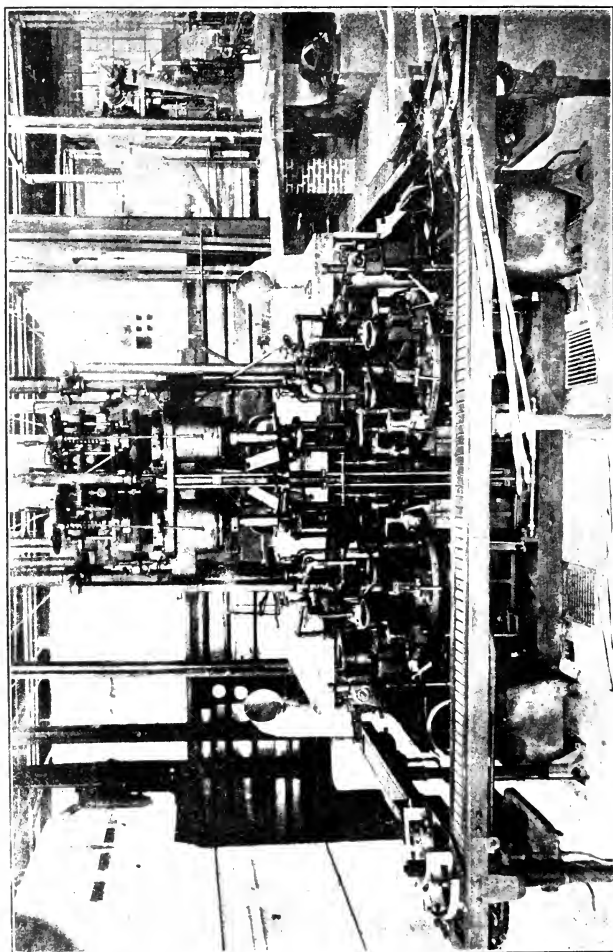

FIGURE 13.— Hartford press machine, a type used for making articles such as tumblers and tableware which require a pressing operation only.

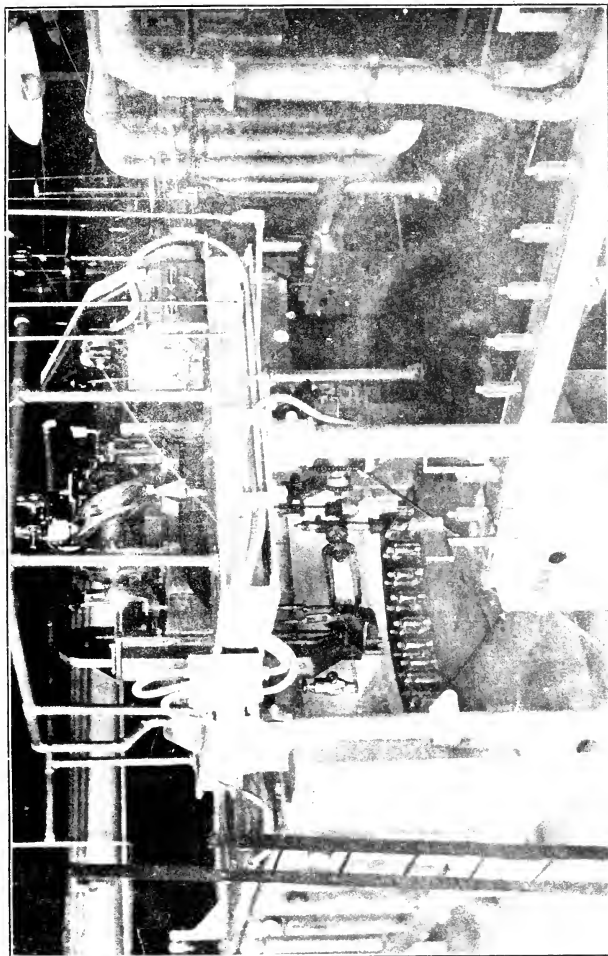

FIGURE 14.—Conveyor, stacker, and lehr. The bottles at the lower right-hand corner have just been fed from the forming machine and are being stacked automatically on the conveyor belt which will carry them through the lehr, or oven, to be cooled slowly.

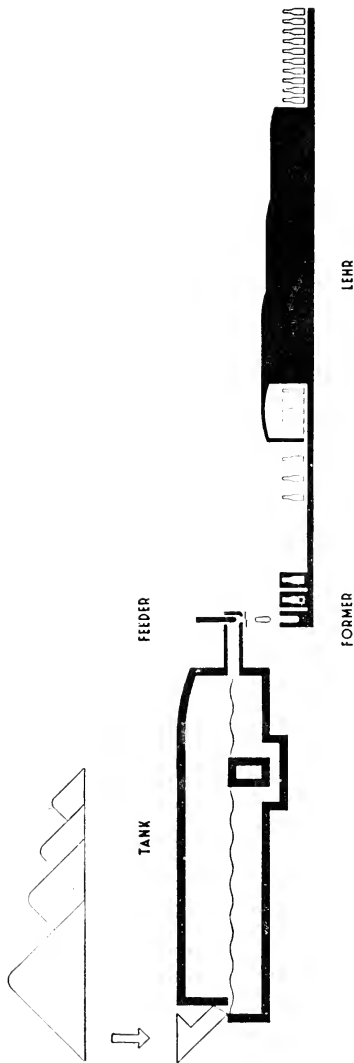

FIGURE 15. Diagram of successive operations in automatic manufacture of bottles, illustrating the gob-fed process. In the Owens suction process the "feeder" and "former" are replaced by a single Owens suction machine, which combines the feeder and former operations. The raw materials are sand, lime, soda ash, and cullet, or broken glass.

A schematic diagram of the manufacture of glass containers by the gob-fed process is shown in Figure 15.

Development of the Glass Container Industry.—The principal divisions of the glass industry are *glass containers* such as bottles and jars; *pressed and blown ware* other than containers, including electric light bulbs, tableware, etc.; and *flat glass*, comprising window glass, plate glass, and similar products. The container branch of the glass industry accounts for slightly less than half of the value of all glass produced in the United States (Fig. 16). The principal products of the division include ware for commercial packers of foods (28 percent); medicines and toilet preparations (24 percent); liquor ware (18 percent); milk bottles (9 percent); fruit jars and jelly glasses for household use (8 percent); and beer bottles (3 percent) (Fig. 17).

Increase in volume and value of the production of glass containers in the past thirty-nine years has been marked. In 1899 there were produced one billion one hundred million containers valued at twenty-one and one-half million dollars. By 1935 this production had increased to slightly less than six billion containers valued at one hundred twenty million dollars (Fig. 18). Preliminary figures for 1937 indicate there were produced more than seven and three-fourths billion glass containers having a value of over one hundred sixty million dollars. Despite this increase in production the number employed in the industry was greater thirty-nine years ago than in 1935. In 1899 there were 28,370 wage earners as compared with 24,044 in 1935. (See Fig. 18.) Consequently there has been a corresponding increase in the average production per man employed. At the turn of the century the average production per man was about 40,000 containers per year. By 1935 this figure had increased to 245,000 (Fig. 19).

Concomitant with this increase in volume and value of glass containers produced the number of companies in the industry has declined precipitously. In 1904 there were 155 companies producing glass containers. At the present time there are forty (Fig. 20). Of these forty, five produce more than two-thirds of the total, leaving less than one-third to the thirty-five smaller companies (Fig. 21).

Sources: United States Census of manufactures for divisions of the glass industry, volume and value of output in 1899 and 1935; Survey of Current Business for preliminary 1937 data on volume and value of output; United States Census of Manufactures and Bureau of Labor Statistics Bulletin No. 441 for early data on number of wage earners employed and production per man; Glass Factory Yearbook (Directory of the Glass Trade) for number of wage earners in 1935 and number of companies; Glass Container Association for production of five largest companies.

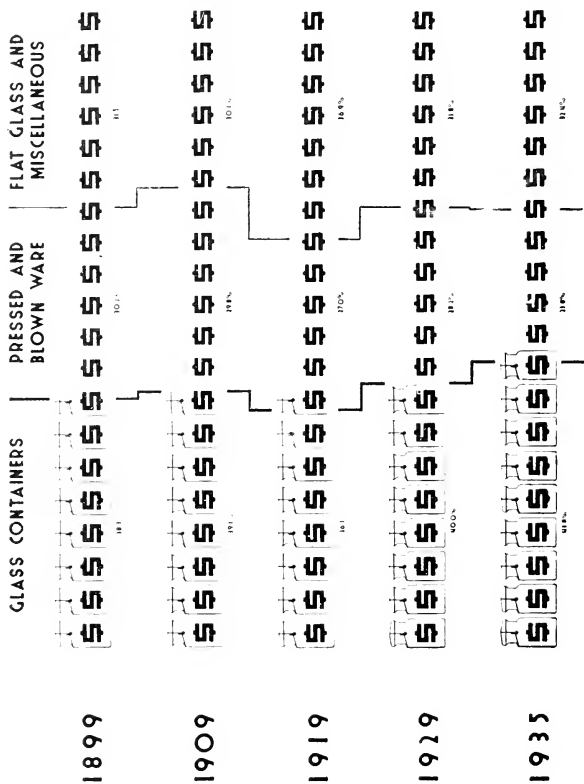

EACH DOLLAR MARK = 5 PER CENT
OF TOTAL PRODUCTION

FIGURE 16.—Divisions of the glass industry.

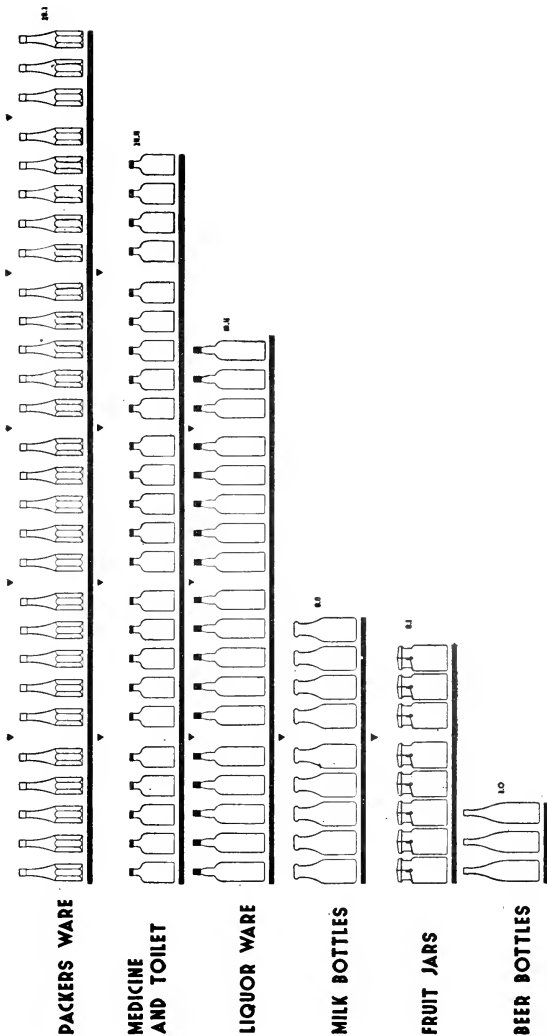

EACH BOTTLE = 1 PER CENT OF TOTAL
 FIGURE 17.—Products of the glass-container division of the glass industry.

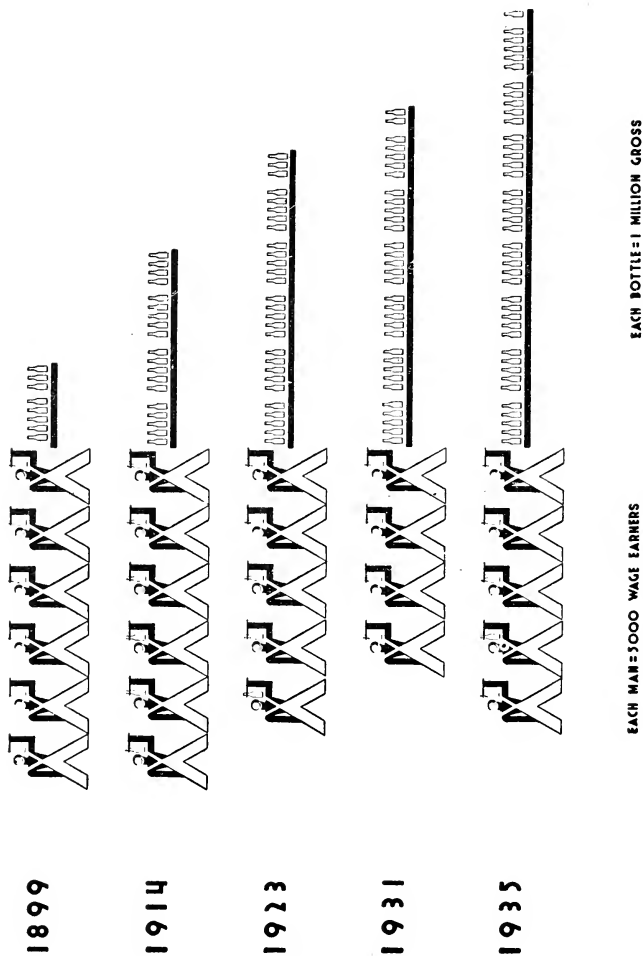
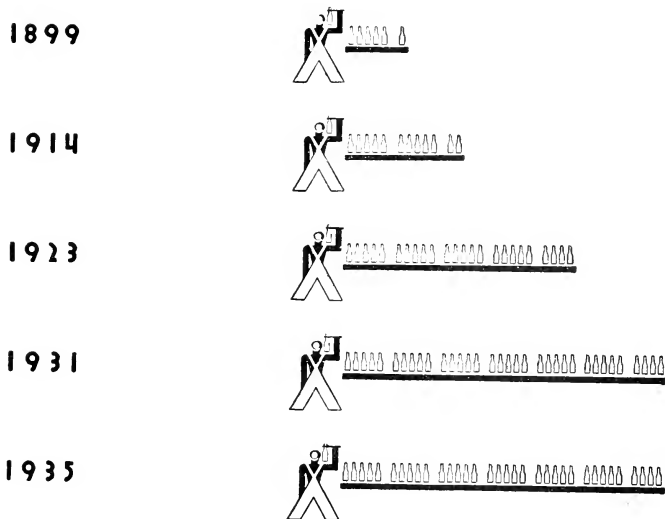

FIGURE 18.—Trend in number employed and volume of output.



EACH BOTTLE = 50 GROSS

FIGURE 19.—Production per man.



EACH SMOKESTACK = 5 COMPANIES EACH BOTTLE = 1000000 GROSS

FIGURE 20.—Trend in number of companies compared with total output.

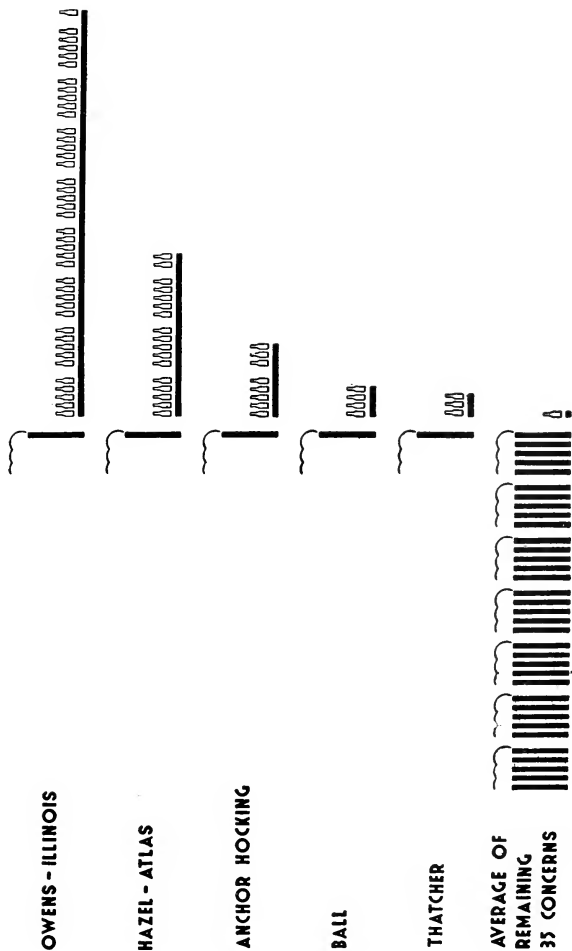

EACH SHORESTACK = 1 COMPANY EACH BOTTLE = 500 000 GROSS
 FIGURE 21.—Output of 5 large companies compared with the remaining 35.

[Legend for " Exhibit No. 113," which appears on opposite page.]

This chart indicates the more important relationships in the glass container industry. The circles on the left side of the chart represent the plants of Owens-Illinois Glass Co., the largest manufacturer of glass containers. This company has an agreement with Hartford-Empire Co., expressed in successive cross-license contracts of 1924, 1932, and 1935. The circles on the right side of the chart represent other companies manufacturing glass containers which are licensees of Hartford-Empire Co. Those on the extreme right represent manufacturers of glass containers who are not licensees of Hartford-Empire Co.

The circle in the upper center of the chart represents Houghton Associates, Inc., a holding company owning 40 percent of the stock of Corning Glass Works, which manufactures specialty glass products under license from Hartford-Empire Co. Stockholders of Corning Glass Works own 90 percent of the stock of the Empire Machine Co., a holding company for glass-machinery patents, which in turn owns 40 percent of the stock of Hartford-Empire Co. The latter licenses Corning Glass Works as well as some 30 glass-container manufacturers, under its extensive glass-machinery patents. Corning Glass Works and Owens-Illinois Glass Co. each own a one-half interest in Fiberglas Corporation, a company recently organized to develop glass wool. In the lower center of the chart is a circle representing Lynch Corporation, the largest manufacturer of glass-forming machinery. It has a cross-license agreement with both Hartford-Empire Co. and Owens-Illinois Glass Co.

Owens-Illinois Glass Co. and the other licensees of Hartford-Empire Co. manufacture approximately 96 percent of all glass containers produced in the United States, while the independents indicated on the extreme right of the chart produce about 4 percent of the total.

(This chart should be retained for use throughout the conduct of the Glass Container Industry hearings.)

EXHIBIT No. 114

[Submitted by A. T. Safford, Secretary and Counsel, Hartford Empire Co.]

RATES OF ROYALTY

The weights below specified are the weights of the finished articles

	Blown or Pressed and Blown	Purely Pressed *
	<i>Per Gross</i>	<i>Per Gross</i>
½ oz. wt. and under.....	7½ Cents	7¼ Cents
Over ½ oz. wt. and not exceeding 1 oz. wt.....	8 Cents	7½ Cents
Over 1 oz. wt. and not exceeding 1½ oz. wt.....	9 Cents	7½ Cents
Over 1½ oz. wt. and not exceeding 2 oz. wt.....	10 Cents	7½ Cents
Over 2 oz. wt. and not exceeding 4 oz. wt.....	11 Cents	8½ Cents
Over 4 oz. wt. and not exceeding 8 oz. wt.....	12 Cents	9 Cents
Over 8 oz. wt. and not exceeding 12 oz. wt.....	13 Cents	9¾ Cents
Over 12 oz. wt. and not exceeding 13 oz. wt.....	14 Cents	10½ Cents
Over 13 oz. wt. and not exceeding 16 oz. wt.....	15 Cents	11¼ Cents
Over 16 oz. wt. and not exceeding 20 oz. wt.....	16 Cents	12 Cents
Over 20 oz. wt. and not exceeding 26 oz. wt.....	18 Cents	13½ Cents
Over 26 oz. wt. and not exceeding 30 oz. wt.....	21 Cents	15¼ Cents
	<i>Per Pound</i>	<i>Per Pound</i>
Over 30 oz. wt. and not exceeding 96 oz. wt.....	½ of a Cent	½ of a Cent
Over 96 oz. wt. and not exceeding 128 oz. wt.....	¼ of a Cent	¼ of a Cent

* Purely Pressed, that is, produced by an operation which consists solely of pressing without the intervention of any air in the mold for the purpose of changing the shape of the article to be produced.

CONCENTRATION OF ECONOMIC POWER

EXHIBIT No. 115

[Compiled by Department of Justice staff from certified data taken from files of Hartford-Empire Company]

Hartford-Empire Company—Annual Receipts from royalties and license fees

Year	Royalties	License Fees	Total
1923.....	\$637, 692	\$128, 812	\$766, 504
1924.....	720, 230	169, 256	889, 486
1925.....	946, 624	428, 761	1, 375, 385
1926.....	1, 423, 956	366, 362	1, 790, 318
1927.....	1, 671, 402	491, 282	2, 162, 684
1928.....	1, 742, 386	469, 100	2, 211, 486
1929.....	1, 952, 307	379, 900	2, 332, 207
1930.....	2, 043, 388	256, 329	2, 299, 717
1931.....	1, 776, 723	108, 600	1, 885, 323
1932.....	1, 902, 000	105, 565	2, 007, 565
1933.....	3, 114, 590	197, 179	3, 311, 769
1934.....	3, 631, 943	223, 588	3, 855, 531
1935.....	3, 959, 876	329, 540	4, 289, 416
1936.....	4, 872, 325	364, 054	5, 236, 379
1937.....	5, 548, 584	516, 678	6, 065, 262
Total.....	35, 944, 026	4, 535, 036	40, 479, 062

EXHIBIT No. 116

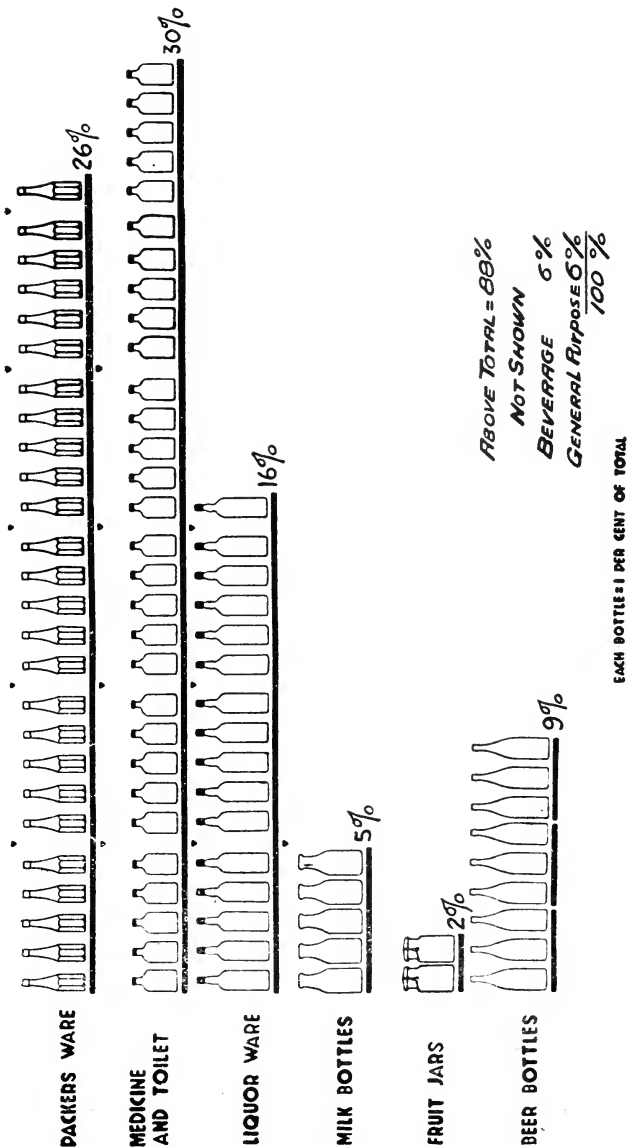

EXHIBIT No. 117

OWENS - ILLINOIS



HAZEL - ATLAS



ANCHOR HOCKING



BALL



THATCHER



REMAINING 35 CONCERNS



EACH SMOKESTACK #1 COMPANY

EACH BOTTLE = 100,000 GROSS

"EXHIBIT No. 118," introduced on p. 405, is on file with the Committee

"EXHIBIT No. 119," introduced on p. 406, is on file with the Committee

"EXHIBIT No. 120," introduced on p. 408, is on file with the Committee

"EXHIBIT No. 121," introduced on p. 410, is on file with the Committee

"EXHIBIT No. 122," introduced on p. 411, is on file with the Committee

EXHIBIT No. 123

[From files of Hartford-Empire Company]

AUGUST 26, 1932.

S. S. SEARCY,
Attorney-at-law, San Antonio, Texas.

DEAR MR. SEARCY: I received your courteous letter of August 23rd, and should like to employ you on behalf of Hartford-Empire Company in its contemplated suit against Three Rivers Glass Company.

In this afternoon's mail there came another letter from Three Rivers Glass Company, as a result of which it may be necessary for us to change our opinion but for the present we are still contemplating bringing suit.

There are a great many factors which I believe would be of considerable assistance to you in understanding the picture and in bringing the suit. For this reason I should like to meet you in St. Louis sometime between September 5th and September 10th.

If you could meet me there I could give you the contracts and the papers involved, and also explain to you the whole situation. We could also meet one another and assure ourselves to our own satisfaction as to the calibre of the persons with whom we are respectively dealing.

Therefore, would you be good enough to either wire or write me if you can possibly meet me in St. Louis between the stipulated dates, and tell me what day is best for you? I have selected St. Louis as being the half-way point between San Antonio and Hartford, but if any other business should carry you North to some other point I could perhaps meet you there.

I enclose herewith opinions of the Circuit Court of Appeals in the cases of Hartford-Empire Company v. Hazel-Atlas Glass Company and Hartford Empire Company v. the Nivison-Weiskopf Company, and also would like to refer you to Hartford-Empire Company v. Obear-Nester Company, 39 F (2d) 769 and Homer Brooke Glass Company v. Hartford-Fairmont Company, 255 Fed. 901, affirmed 262 Fed. 427. These, I believe, will give you an adequate background of the glass art and the kind of machines which we call Feeders.

Hartford-Empire Company is engaged in the development and manufacturing of machines for making glass articles, and our two principal sources of income are from what we call Feeders and Lehrs.

These machines we lease and license under a standard form in which we retain title and in which the licensee agrees to return the machinery in the event we revoke its license. The licensee pays royalties on each article of glass manufactured with the Feeder, but in the case of the Lehr there is a flat monthly amount payable for the use of the Lehr. We have a provision in the contract that if the licensee fails to pay its royalties we are entitled to revoke its license.

In August 1929 Three Rivers Glass Company was operating four machines which infringed our patents. They came to us and wanted a license under our patents and agreed to pay damages for their past infringing use. They also wanted a license to make milk bottles, but by reason of our prior commitments we were not in a position to give them a license for milk bottles.

We finally licensed them to use three Feeders, but the fourth Feeder we did not license, and since then they have continued to make milk bottles on a machine which we believe to infringe our patents. We have not brought suit against them for this infringement mainly on account of the expense involved in bringing such

a suit for just one machine, and also because we have been fully engaged in trying suits and arguing appeals in cases in the Third, Sixth and Eighth Circuits—opinions to which I have referred you above.

In 1930 Three Rivers Glass Company substituted our Hartford Single Feeders for their other Feeders. Since then they have been consistently behind in their payment of royalties. Last Fall we told them that we were going to revoke, and at that time they promised most faithfully to keep up their payment of royalties, and we permitted them to continue. They are far behind now and we have sent them notice that their license is revoked, the revocation to take effect September 1st.

We control 90% of the glass feeding machines used in this country, although there are certain other methods of making glassware. In return for the various manufacturers paying us royalties we render to them general engineering service and are in much closer contact with them than if we were merely a selling house. We get all their problems and hear all their troubles, and wherever possible try to assist them.

Three Rivers Glass Company has been a perpetual thorn in the side of all the manufacturing companies. It won't assist the other manufacturers in any manner in maintaining general price levels. It isn't because they are more efficient than any one else (which is a justifiable reason of course for lowering the price), but because they are just simply selling at an actual loss in order to stay in business.

We should like, for reasons of the general commercial situation and also because we feel there is no hope of Three Rivers ever paying us, as they should, to take the machinery out of their factory. This may, of course, seem to you to be a hard-boiled attitude, and of course it seems that way to the Three Rivers Company. We would prefer not to take such a drastic step, but the fact that they are using an infringing feeder, that they are always behind in their royalties and in their paying for spare parts, and the fact that they are a perpetual nuisance to the other manufacturers makes it imperative for us to proceed against them.

I am having prepared copies of the contracts and all of the correspondence which might possibly relate to this matter, and this material I could bring with me when I saw you.

We have also pending in the District Court for the Eastern District of Pennsylvania a similar suit which is to be tried in October, and I enclose herewith a copy of the complaint in that case.

Your suggestion that the suit be brought in Federal Court I believe is very wise, and a suit for specific performance of the contract to return the Feeders is the kind of action which seemed most advisable in Pennsylvania.

I enclose herewith a copy of our Standard Hartford Single Feeder contract which is practically the same as the one which Three Rivers entered into with for its Three Hartford Single Feeders, and I also enclose herewith a Hartford Lehr Contract. These will give you the opportunity of seeing on what basis we make our legal claims for the return of the Feeders.

You, of course, know your courts and their slant toward any particular question, so that if during the course of our dealings with you you feel it is wiser to do one thing or the other I should not want you to refrain from giving your opinion.

Very truly yours,

HARTFORD-EMPIRE COMPANY,
_____, Secretary.

(Mr. A. T. Safford, Jr., left before he was able to sign this letter. R. L. B.)

EXHIBIT No. 124

[Paper from files of Hartford-Empire Company Reproduced at request of agent of Temporary National Economics Committee. A. F. SAFFORD, Jr., Secretary.]

[Written across face: for Mr. Safford.]

MARCH 26, 1928.

MEMORANDUM AS TO HARTFORD-FAIRMONT AND HARTFORD-EMPIRE HISTORY AND POLICY

HISTORY

The Hartford-Fairmont Company was organized in 1912. You can get the best background for the history of this company by reading my brief and findings in our Board of Tax Appeals case in the appeal of the Hartford-Fairmont Company. I want to add also some further considerations of this history

(1) The glass industry (excluding sheet and plate glass, with which we have nothing to do) was in 1912 in a backward state mechanically and just about right for change to automatic machine processes in order to meet the change of American industry toward mass production. Our development, therefore, came at the moment when it was needed and the result has been that the glass industry has absorbed from us a very large amount of expensive machinery.

(2) Our process had one important rival.—The Owens Bottle Company, the most powerful glass concern in the world. Its process was entirely different from ours. It came into commercial use about 1905 and dominated the industry until about 1917 when our process began to get a foothold. Up to 1924 there was sharp conflict between us and Owens, with some patent litigation. In 1924, after long negotiation, the two companies got together in a cross-licensing arrangement and have since then worked in exceptionally close understanding. There is, however, no combination between the two.

(3) We began our commercial expansion in 1917 when our first feeders were put into production. It was at once apparent that if we put out these machines broadcast, without restriction, we would disorganize the whole industry, which was then divided into a large number of small units, and most of these manufacturers would not be able to refrain from using practically all the savings produced by these machines in fighting with each other. In fact, our first group of licensees said so expressly and urged us to take measures to prevent such a result.

(4) Consequently we adopted the policy which we have followed ever since of restricted licensing. That is to say,

(a) We licensed the machines only to selected manufacturers of the better type, refusing many licensees whom we thought would be price-cutters, and

(b) We restricted their fields of manufacture, in each case, to certain specific articles, with the idea of preventing too much competition.

(c) In order to retain more complete control of the situation, we retained title to the machines and simply leased them for a definite period of years, usually 8 or 10 years, with the privilege of renewal of a smaller additional term.

(5) In specifying the various fields of ware for a given licensee, we have, with a few exceptions, based the classification upon the use of the article rather than shape or other physical characteristic. Glass containers have so many shapes that it is practically impossible to classify them by shape and very often numerous different shapes will be used for the same purpose, so that use of the container is the basis for our classification except in a few cases.

(6) Quite early in our history we foresaw that the glass industry, like others, would doubtless go through a process of combination, which as a matter of fact has occurred. We felt it to be to our best interest, as well as for the best interest of the whole industry that we should use our influence to steady the industry as much as possible, with a long-distance view towards its general prosperity. The men at the head of our concern took this long-distance view deliberately and have ever since maintained it. For example, although the Hartford-Fairmont Company was organized in 1912, it paid its first dividend on its common stock in 1924. Up to that time it had put back into development all of its profits and considerable amount of cash received from sale of patents abroad.

(7) We have thus gradually evolved the theory of what may be called a "glass equipment concern." In this change of the industry to mechanical equipment, two courses were theoretically possible for the manufacturer—

(a) He might at his own expense develop automatic machinery and protect the same by patents for his own benefit. Such development and patent protection is an extremely expensive process and if the manufacturers generally had followed this course, there would have been a very large duplication of effort and expense.

(b) On the other hand, the manufacturer might select some outside concern, like the Hartford-Empire Company; entrust to it the work of developing and protecting machinery of the glass industry generally and support that concern in its development by paying a proportionate contribution which in this case was best measured by royalties on production.

(8) The latter course was the one which the manufacturers very wisely chose. The result has been that the Hartford-Empire Company has now become the most important glass equipment concern in this country and probably in the world. This means that H-E has a duty toward the whole industry not only of developing and supplying machines immediately needed, but of keeping in advance of that need by inventing further improvements. It also must act as a source of service and information for its licensees in all technical matters relating to their business and must help to steady, as far as possible, the general

glass industry. H-E has done this to the best of its ability; has spent enormous sums in machine development and patent litigation, as well as in research along mechanical, physical, and chemical lines.

(9) As to the foreign situation, we have pursued a somewhat different policy. In most cases we have sold our foreign patents outright, it being too difficult to establish a workable licensing system abroad where we could not be in touch with our licensees and could not give them service. We have sold foreign patents in some 15 or 20 countries and have especially close working arrangements with British Hartford-Fairmont Syndicate, a London concern, and St. Gobain Glass Company in Paris. We have still a number of foreign patents unsold, especially in Central Europe.

(10) One special line of recent development has been in refractories. Glass is melted in a large tank holding 200 or 300 tons of molten glass and the tanks built of ordinary fire brick wore out rapidly, usually lasting not more than a year, with a very large expense to the manufacturer for replacement and especially for loss of overhead and business during the replacement.

(11) In combination with Corning Glass Works—with whom we have rather close working alliance—we have gone into a development of glass tank refractories of a much higher quality and the two companies have joined in erecting a plant for making these refractories in Louisville, Ky., by means of the Corhart Refractories Company and are just beginning production.

GENERAL CONTRACT POLICY

It will be easily understood that with the foregoing history, the contract relation of H-E are very complex and numerous. They involve several different classes of contracts—

(a) The ordinary standard licenses of feeders, forming machines, lehrs, stackers, conveyors and the like which are almost always represented by printed forms which differ usually only in the field of ware permitted.

(b) Contracts which have arisen as the result of conflict or duplication of development between H-E and other important companies. These are specially represented by our contracts with Owens and with the Corning Glass Works, which, broadly speaking, are in the nature of cross-licenses.

(c) Contracts which have arisen as the result of our acquisition of other concerns and processes, illustrated by our contracts by which we purchased patents and assets of the Howard Feeder Company and the patents, assets and licenses of Tucker, Reeves & Beatty.

(d) A fourth class, which is much like the first one, or what are known as "General Agreements." These arise simply where some licensee becomes so large that instead of issuing to that licensee a separate printed license for each machine, we make a general agreement with the licensee and simply issue a short form single page license to cover each machine taken. These General Agreements usually raise two or three important special questions. For example, the licensee in such case usually wants to be assured that he will get as many more machines as he may want, and secondly, that he will be able to get on reasonable standard terms our future developments along his line.

(12) One particular feature requires considerable attention, namely the so-called "exclusives." In the early history of the Company and in order to secure business, we granted to certain interests the exclusive right in certain of our machines for particular fields of ware. For example, we granted to four milk bottle manufacturers the exclusive right in certain of our feeders and forming machines for milk bottles. These concerns were later taken over by one concern which still holds that exclusive. We also granted exclusives on certain high qualities of glass and certain special lines of ware of the Corning Glass Works, such as bulbs, glass cooking ware, signal ware, etc.; also exclusives on lantern globes and one or two other minor lines of ware.

We have had so much trouble with these exclusives when dealing with other parties that our policy is now decidedly against them. We found that in making cross-licenses and adjustments of patent conflicts, these exclusives frequently stood in the way of such adjustments and caused us a great deal of trouble. It is, in fact, necessary to have these exclusives constantly in mind in considering any proposed contract.

(13) Another special feature is the so-called most favored provision. In number of the "General Agreements" the licensee has insisted that he get as favorable rates and terms as any other licensee of ours under like conditions. Also that if we later make such more favorable terms to others, then the same shall, ipso facto, come to him.

This, as you see, means that we must constantly be on our guard in granting new licenses or in widening old ones, because whatever concessions (generally speaking) we grant to a particular licensee, must at once be granted to all those enjoying the "the most favored" provision.

EXHIBIT No. 125

Paper from files of Hartford-Empire Company reproduced at request of agent of Temporary National Economics Committee—A. T. Safford, Jr., *Secretary*

MEMORANDUM ON POLICY OF HARTFORD-EMPIRE COMPANY, FEBRUARY 18, 1930

The history of the Company shows a rapid growth. The first real royalty returns were received December, 1917—\$11,392. Gross royalty returns for 1929 were \$1,972,307.

The Company has been forced by trade and production conditions to develop many types of machines. First, the original paddle feeder—then the paddle-needle feeder—then the single feeder—then two distinct types of full automatic forming machines which greatly increased output and speed of the feeders—then an entirely new lehr—then the paste mold machine, intended for greater bulb and paste mold tumbler production—then a rather radical type of an individual section forming machine which has great merit in a limited field, but which did not prove to be "universal"—then automatic stackers, transfers, conveyors, etc., as well as very important developments of new refractory materials—then some original work in furnace design and electric melting.

The business conducted by the Hartford-Empire Company may be divided into four distinct and important divisions, as follows:

(1) THE EXECUTIVE-OPERATING DIVISION

This Division handles all negotiations, and financial and legal matters. It includes the Accounting, Service, Installation, and Manufacturing Departments.

(2) THE PATENT DIVISION

This Division handles all patent matters and inventions and patent litigation. It is responsible for the creation, filing, and prosecution of all applications to patent issue.

(3) THE DEVELOPMENT DIVISION

This Division consists of highly trained mechanical and technical engineers and inventors, as well as the drafting force. It is responsible for all invention and development work.

(4) FOREIGN DIVISION

This Division handles all foreign correspondence and shipments, and foreign patent work, and carries on preliminary negotiations for sale or license of patent rights or machines in foreign countries—thus far in seventeen such countries.

POLICY OF A DEVELOPMENT DIVISION

The question to be considered is a question as to the Development of General Equipment. How far a general development and equipment company, like Hartford-Empire, should go in spending time and money in inventing and developing machines and processes for the glass industry, *beyond* immediate and specific needs where definite savings or income can be reasonably estimated.

To put it differently, all developments may be classified as follows:

Class A

Continual minor improvements to Hartford equipment now in operation. Examples: Forehearth improvements, giving better temperature control—better shearing mechanism, feeder clay parts, lehr belts—etc. etc. (NOTE.) Licensees demand this kind of engineering work. It reduces their costs, retains their support, insures the maintenance of present royalty rates for Hartford, and often increases total royalty returns.

Class B

Machines or apparatus of new design to be used with established machines, and which will give the whole unit much greater speed and efficiency, as well as a larger range of articles. Example: Canfield H. Paste Mold Machine; Hartford Individual Section Machine; also Automatic Stackers, Automatic Conveyors, and Automatic Take-Outs. These types should invariably increase royalty income.

Class C

Specific equipment providing an entirely new source of income. Example: Hartford Lehr.

Class D

Tank design, reductions in melting cost, and glass compositions. These have a distinct relation to machine equipment. In fact, any advance in furnace construction or glass composition may require a complete change in machines and auxiliary equipment. (NOTE) It therefore seems essential that Hartford should keep in close touch with all progress in tanks, melting, and glass composition. It should be able to make contributions along these lines, as they are parts of the total production chain. Hartford has already protected itself to a degree in this field.

Class E

General Research work and study and experiments covering means of producing an entirely new or radical process of fabricating glassware, which process, if successful, will supersede present methods, and will secure higher royalty rates.

During the last five years all development undertakings of every nature by the Development Division show a direct cost of \$927,000 and an overhead expense (salaries and expenses not directly chargeable to these specific undertakings) of \$259,000. Incidentally, the lead men of this Division have assisted in an advisory capacity and otherwise to all other Divisions.

Direct charges-----	\$927,000
Indirect charges-----	259,000
Total-----	1,186,000
Direct receipts from development work put into use--	1,375,387
Total cost-----	1,186,000
Profit-----	189,387

Several of these development undertakings, to the cost of \$75,000 and more are still in process of completion; may yet have considerable earning power.

COMMERCIAL SITUATION

Prior to 1905 practically all glassware was produced by hand. At that time the Owens Suction Machine came into commercial use. By 1913 the Owens machine was producing a little less than one-third of the country's total production of containers, estimated as 19,000,000 gross.

Now that total is about 30,000,000 gross, divided as follows:

40%	made by suction machines.
35%	" " Hartford gob feeders.
25%	" " "outside" feeders and by hand.

NOTE.—"Outside" feeders are gob feeders which infringe our rights, or any other form of automatic feeders controlled by others.

Thus in the last twenty-five years, and mainly in the last ten or twelve, the whole glass industry has become mechanized. This change has carried with it all the new problems necessarily arising from such a radical advance.

SITUATIONS WHICH HARTFORD WAS FORCED TO RECOGNIZE

Class A. Division—Minor Improvements.—There can hardly be any grounds for criticism for development and engineering work falling under Class A.

Class B. Division—Forming & Handling Machines.—As regards Class B—on the success of the Hartford feeder in 1918, it became clear that the then existing Forming Machines could not meet the speeds or capacity of the feeders. The Illinois Glass Company refused to take any interest in our feeders until we had

efficient Forming Machines with the feeders. Hartford then developed two types of Forming Machines, and immediately the Illinois Glass Company entered into a general agreement with Hartford.

The paste mold bulb and tumbler machine ("H" machine) was undertaken for two reasons. *First*, as a more efficient machine to super-ede the Canfield F. machine for bulbs. *Second*, to produce at a lower cost paste mold tumblers, which tumblers then had a considerable market. During the three year development of this machine two adverse things happened: (a) the Corning 399 bulb machine came into being; and (b) the "hot mold tumbler" captured a large part of the paste mold tumbler market. The "H" machine thus became obsolete. This is a good example of the unexpected changes in the industry.

The Individual Section Forming Machine developed by Hartford was undertaken because of a demand by Hartford's licensees for a four-mold machine especially adaptable for small orders. This machine, although it earned us last year \$25,000 in royalties, has not proved to be a universal machine. It has, however, to some degree increased our feeder royalties. Certain types of ware can be made on it which can not be made on any other machine. Many original principles have been developed in it, applicable to other machines. These principles are now our property and are an important link in the development of any future Forming Machines by Hartford or by outsiders.

Some of the values of this type of machine have lately been depreciated by the Owens Plural Mold Process, for sucking up and forming of two, three, or four bottles at a time.

We do not consider this Individual Section Machine development as a loss, even though the machine itself will never show a cash profit.

Also falling under *Class B*, the Hartford company has developed Automatic Stackers (which automatically handle the ware from forming machines into lehrs) as well as Automatic Conveyors, and Take-Outs. These have proved not only profitable themselves, but have increased feeder royalties because they have insured a higher percentage of ware packed.

Because of the advent of the Knox-O'Neill machine, Hartford is again being forced to develop for its licensees a Forming Machine which, with Hartford feeders, will produce containers at less cost. Hartford would have much preferred to spend this money in more radical developments in furnaces or fabricating processes. But to meet an emergency, and to appease Hartford's licensees, it seemed to Hartford that it must furnish its licensees as soon as possible a new Forming Machine which would fulfill their requirements.

Class C. Division—Specific Equipment to Earn New Income.—The Hartford Lehr speaks for itself as an outstanding development, exceptionally profitable. Domestic lehr royalties in 1929 amounted to \$157,000. Foreign sales of lehr rights have amounted to \$204,000. This lehr development represented as much of an advance in the art of fabricating glass as the feeder did over the hand process.

Class D. Division—Tanks, Glass, Etc.—There are many sound reasons why we should apply money to Class D. The prestige of Hartford is such that many licensees have remained loyal and paid royalties without established patent protection. This is because of their belief that Hartford as a general equipment and development company stands ready to advise and assist them in all problems of fabrication of glass containers.

For example—it is recognized today that the cost of melting glass is excessive and represents far too high a ratio to the other costs. Our engineers know that substantial savings may be made by radical developments in tank design, by improved means of heat application, involving problems of combustion, by the use of improved refractories, and by the development of improved glass formulas for the increase of tensile strength and reduction of weight.

Hartford's expenditures in the development of new and better refractories seems entirely justified. Hartford has already acquired options on fairly valuable rights covering electric melting, and now owns rights for melting by revolving tanks.

Class E. Division—Research & Experimental.—Hartford recognizes that the art of fabricating glass by the gob feed method is well established, and that there is probably no chance for radical developments along this line per se.

Hartford also recognizes that the big Owens Suction Machine is well established, and that there is probably no chance for radical development there.

On the other hand, Hartford in looking towards the future has a very strong incentive for carrying on considerable research and experimental work along two distinct lines.

One line is a combination of methods somewhat approaching gob feeding, known as the Howard Auto-Blow.

Another line is a simplification of and elimination from the big Owens Suction Machine method.

The preliminary work done on these lines justifies further research and experiment. If Hartford's patent position should fail, then it should have ready a new process which so far exceeds the gob feed process that Hartford will not only maintain its licensing position, but increase the royalty rates.

Hartford always has very practical considerations for developing, if possible, a radical suction method clear from Owens patents. If this can be accomplished commercially Hartford would be relieved of paying Owens a tribute of some \$500,000 a year.

Hartford feels justified, therefore, in making a budget allowance for Division E.

REMARKS

It should be thoroughly understood that Hartford's development problems are of a universal nature. They are not confined to any one specific set of problems pertaining to any one article.

When a manufacturing company undertakes to create for itself improved machinery, that machinery merely (a) has to meet a certain specific and comparatively narrow line of product; (b) under one particular set of conditions; and (c) will be developed and used practically by the same personnel that is directing the main production work of the company.

Equipment developed by Hartford, on the other hand, must produce efficiently *all kinds of glass containers of various shapes, capacities and weights*. Hartford could not afford to consider any particular manufacturer's problem in regard to one particular article unless the manufacturer guaranteed to reimburse Hartford for the full cost of the development plus a profit.

The Hartford feeder is now delivering glass from $\frac{1}{2}$ oz. up to 5 lbs. The container manufacturers are not interested in Hartford equipment unless it will handle their entire line of ware. This adds many burdensome problems to the development and engineering staff of Hartford. You may have a most efficient means for producing a 5 oz. bottle. You may have a most efficient means for producing a 16 oz. or 20 oz. bottle. But a machine to produce both must be a compromise.

Action required to meet conditions

It is impossible to meet such diverse conditions without a very *general* (as distinguished from specific) knowledge of glass and mechanical problems. In other words, that knowledge must approach much more nearly that which results from general research.

The element of time adds a further uncertainty. The average time between the first conception of a new machine and its final commercial success is about 3 years. This period permits of important changes in the whole art. Only fairly *general* knowledge, experience, and experiment can qualify an organization to meet the contingencies that thus arise.

LACK OF PRECEDENTS FOR POLICY

It is difficult to make convincing the proper policy for the Development Division (which in itself is really a Development Company) because such companies are exceedingly rare. Precedents are almost wholly lacking, and Hartford has been obliged to chart its own course in a large and fast changing field of conditions. The main fact, however, that Hartford has come up from insignificance, beginning with a few patent applications and no income, to its present position of large income, wide range of patents, and its unique standing in the industry, all in the course of less than fifteen years, and apparently has made only a few serious mistakes, and none fatal, is a fair evidence that its policy in general has been substantially correct.

It has been by no means an easy or routine task to steer a correct course during the enormous changes in methods, combinations, and business conditions arising in this period. Hartford has followed one definite policy, namely, that the future success of the Company could not rest on feeder income alone, but that the growth and asset position of the Company could only be insured by a development of methods and equipment applicable to the entire art of fabricating glass containers. Hartford has considered that the entire ch. in comprised the furnace link, the melting link, the feeding link, the forming link, the annealing link, with

such auxiliary equipment as was applicable to each of these links, and that it would be a short-sighted policy to merely confine our efforts to the feeding link alone.

Hartford feels that this policy has justified itself, even though the profits over the past five years have probably been less than if Hartford's policy had merely concentrated on one line. Hartford is definitely convinced that the narrower policy would have been unsatisfactory to its licensees, and would not have assured Hartford of their support. Neither would Hartford's organization have developed its potential ability or knowledge of glass fabricating problems. Neither would the value of the capital stock of the Hartford-Empire Company have approached its present considered value—a recent sale in the open market having taken place at \$62 a share.

Hartford points to the example of what took place in the Owens Company.

This Company years ago thought that their suction machine would for all time dominate the industry. They therefore practically abandoned development and research work as too costly. When the original Hartford feeder came into being, they took no stock in it—did not recognize the future of gob feeding—and deliberately let gob feeding come into commercial use. They thus sacrificed welfare and profits.

After gob feeding was established the Owens Company spent \$1,000,000 in building a Forming Machine for gob feeders. A few were built, but have been abandoned.

LONG DISTANCE POLICY

The Management at Hartford feels that if we are to have the same success in the future that we have had in the past, and if we are to provide for a long future of satisfactory income, we must keep in the forefront of development.

We believe that a certain proportion of our development budget must go to pure research and experimental work.

Three years is the normal period from invention to commercial success of a machine or process. Hartford must be ready to supply improvements when needed, or others, more prepared, will get the business. Hartford must therefore look ahead and be ready.

All licensees have an inherent dislike to paying royalties, but they will pay royalties if they are assured that Hartford will apply some of those royalties to an extensive development program. They probably would prefer to have Hartford do development work for them, rather than attempt it themselves, and they recognize that Hartford has built up a strong organization, skilled and adapted to such work.

They therefore have a right to expect Hartford to be continually working on methods and equipment to reduce their costs.

It is a most difficult thing for Hartford intelligently to budget the costs or results to be obtained under Classes D and E until such developments have passed through the experimental stage, and have received the general report of the Patent Department, and a design has taken a definite form.

An example of this is the Howard Auto-Blow. Howard is now experimenting with crude and inexpensive apparatus in testing out an invention which seems to be based on sound fundamentals.

Two practical glass problems have arisen in actual experiments. Howard thinks he can overcome these problems, but just when or how remains to be seen. It may be two weeks, or it may take three months. His solution may be quite simple, or fairly complicated. No one knows. But we all agree that if successful, his contribution will be very valuable and far in excess of any cost involved during the experimental stage.

The same consideration must be given Peiler and Canfield, who have produced some very interesting preliminary experiments applied to suction.

It is quite a simple matter to make up the Development Company budget in advance, by quarters of a year. It is not a simple matter to make up the budget for the entire year, except of course we do, and always, have decided at the first of each year that we will allocate to the Development Company for the year a total amount of money. This total has been fairly rigidly adhered to barring one or two exceptional cases, but at the end of each year we have found that we have spent much more money on Projects 2 and 3 than we anticipated, and much less on Projects 4, 5, and 6.

PATENT DIVISION

The question here is: How far should we go in prosecuting inventions to patents, beyond those inventions which clearly cover machines in commercial use.

THE MAIN PURPOSE IN SECURING PATENTS

In taking out patents we have three main purposes—

(a) To cover the actual machines which we are putting out, and prevent duplication of them.

The great bulk of our income results from patents. Between a feeder protected by patents, and one not so protected, there is the cash difference between one ordinary manufacturing profit of, say, \$1,500, and a royalty return of at least \$30,000 over 8 years. This theory also applies to other equipment.

(b) To block the development of machines which might be constructed by others for the same purpose as our machines, using alternative means.

We have in mind such machines as the Hillman machine; the Roirant type of machine; the Knox-O'Neill machine; improved stream feeders; vacuum and pressure feeders; ribbon feeders; forced feeding or down suction feeding; and auto-blow methods of feeding, as well as various types of pure forming machines.

To ignore this form of protection may result in a competitor's having an estoppel or hold on our own developments.

(c) To secure patents on possible improvements of competing machines, so as to "fence in" those and prevent their reaching an improved stage.

There is also another, rather minor, purpose in securing patents. It corresponds with research in machine developments. Occasionally patentable ideas will appear which deal more with general principles. They may have no immediate and apparent application. But they may so relate to the possible future as to merit some time and expense.

Uncertainty as to Patent Futures

Nothing is more plain from our actual 17 years' experience than the uncertainty as to the future practical value of a given patent claim. In estimating this we are faced with several unknown quantities.

(a) We do not know what claims by other inventors may be in the patent office.

(b) We can not tell what "anticipations" of domestic and foreign patents may finally be cited against us when we get into Court.

(c) We can not tell what will be the final form of the machine we are trying to cover, or what form of words will best cover it.

It has happened several times that we have actually developed an efficient machine to a working stage before our Patent Department could determine and formulate its real patentable features, or decide whether the machine was free from patents owned by others.

Take our lehr. Several large concerns attempted for years to develop a self-heating lehr. Then our lehr came along and swept the market. But it was not until after it had been considerably developed that our Patent Department and inventors finally analyzed the features that were patentable and that made our lehr superior.

This shows how uncertain the future is as to patent claims, and how unsafe it is to take a particular claim and assume it will be the one which three, five, or ten years later we shall be glad to rely upon in Court.

Thus the only safe thing to do is to cover all possible forms of claims, well knowing that many of them will be superfluous.

CONCRETE EXAMPLES

The "Plunger Principle"

The following examples illustrate the foregoing. The most striking is our experience with the "plunger" principle, as exemplified by our paddle-needle feeders and single feeders—an experience which still rouses active emotion and disputes in our organization.

In the early days of 1912 and 1913, Mr. Peiler developed definite ideas as to both the paddle feeder and the plunger feeder. For various reasons, those then in charge deemed it wisest to proceed with the commercial development of the paddle feeder. Mr. Peiler had demonstrated with tests the feasibility of both paddle and plunger. It was a case in which, as it has now turned out, the poorer of two alternatives was selected for the commercial development. The better (plunger feeder) principle was pushed aside for the time by the paddle feeder development. The plunger feeder was not actively worked upon again until 1916 and later.

For various reasons unnecessary to mention, no patent application was filed during 1913, 1914, 1915 and 1916 upon the plunger feeder.

The result of this failure to file on this alternative form, gave others a chance to obtain positions in the plunger feeding art which put us to great expense in interference proceedings and made necessary the purchase of Howard and Miller, and has caused us a tremendous amount of work and added expense in our suits.

There is no doubt that had the conditions been but slightly different, we would have lost the benefit of Peiler's work on this principle.

Example 2. The Lott Patent

A different example is that of the Lott patents. We probably could have bought these in 1918 for around \$15,000. Their future importance was not seen. We turned down this purchase under definite orders to reduce expenditures. And yet these patents finally became the main inducement in forcing us to go into the "Owens General Agreement," under which we have paid Owens large sums up to date and will continue to pay still more in the future. There are a number of other patents in this class.

Example 3. Heavier Than Glass Patent

The "Heavier Than Glass Patent" which, in its inception was not given more than ordinary value, has now a quite important bearing on the entire refractory situation.

Example 4. Knox-O'Neill Machine

Whitall-Tatum, back in 1911 and 1912, practically invented and developed the Knox-O'Neill machine, but it was then completely covered by the original Owens suction patents (now expired) and they abandoned the development.

In the meantime, the inventor who was associated with them, Mr. Cox, took out a patent which lay dormant for some years. Then, on the rise of the present Knox-O'Neill machine, it became suddenly of obvious importance. We had to buy it for \$5,000, and it may become worth a great deal more than that in our general attack on the Knox-O'Neill machine.

Example 5. Peiler Punty Patent

This case is fresh in memory. This was a patent of 1926, but an invention of 1912. Suddenly its application to the Danner Tube Machine became apparent, and we realized \$350,000 on it.

Example 6. Empire Machine Company Patents

There is the case of the patents of the Empire Machine Company, based on which that Company was able to acquire a very large interest in Hartford-Empire Company after having prior to that time, secured extraordinary earning from them.

"FENCING IN"

Many further examples can be cited where applications now owned will have a distinct bearing on our future developments, as well as on developments in many lines by others, and it would seem to us to be the wisest and safest policy to protect all ideas which are so new as to have patentable possibilities.

We now have a number of applications which were filed to definitely forestall the development of competing machines by others.

Continuing the Monopoly by Us or Others

It often happens that if minor improvements are protected by patents, machines and processes licensed under the original basic patents are given a much longer earning life by the fact that the minor improvements continue the protection on the machines, and even when the basic patents expire, others are prevented from using the latest commercial form of the machine.

Example: The Owens basic patents expired several years ago. Nobody, however, dare use the present type of Owens machine because of improvements covered by minor patents. Likewise, if the original patent protection obtained on particular machines should not be sustained by the Courts, yet a second line of defense patents covering details and improvements may become a most valuable asset.

It has always been our ambition to obtain patents which will be related to furnace, melting and refining, feeding, delivery, forming, automatic handling, carrying, stacking and annealing. Conceivably we might lose patent domination of one or more important links, but still retain practical control of the whole chain by means of controlling the most efficient form of the other links.

Refractories and Furnaces

In one sense, these two items overlap, and in another they are separate.

Considering the refractories separately as refractories, we believe that they have undoubtedly a two-fold value. Obviously, better refractories for furnaces, resulting in better conditioned and better controlled glass, will give better pack, and higher feeder royalties.

The patent cases on furnaces deal primarily with furnace design, batch feeding, and furnace handling. They are primarily valuable to us as supplemental protection to feeder royalties, and are justified on such basis as well as constituting a control in fields which may hereafter become important. Many of the cases are more than merely secondary protection, as they relate as well to feeder forehearth^s.

Examples of furnace cases which are applicable to forehearths and thus are protection to our feeders are (1) Amsler case 1853 on a particular type of container; and (2) the two Raeder cases 1896 and 1897 applying to electric melting and conditioning of glass which obviously is as applicable to a forehearth as to a furnace.

PATENT APPLICATIONS 1927-1929

Analysis

The following covers primarily our commercial devices and the new cases which were filed as protection of these devices:

- (1) Feeders—including P. N.'s, Single feeders, Howard feeders, Tucker & Reeves feeders, Miller feeders, and Bethel feeders.
- (2) Lehrs—including our combustion Lehr and our new electric Lehr.
- (3) Our mechanical stacker.
- (4) Escalator buck.
- (5) Shaping machines—including our milk bottle, twin press, press and blow, narrow neck, I. S., No. 12, and F. and H.
- (6) Refractories—including the various types developed by Willetts.

Definitions

"Direct patent protection" means those patent applications which directly read upon or cover our devices, parts thereof, or proposed physical improvements thereon.

"Indirect patent protection" of a device, includes those applications which prevent the use or improvement of an existent or possible substitute for the device. This "indirect protection" seeks to block competing devices which would lessen our income.

Of the 223 cases filed in the three years 1927, 1928, and 1929, 200 are direct or indirect protection to the devices mentioned above; 88 applications being "direct protection" and 112 "indirect protection." The following chart shows these 200 cases:

	1927		1928	
	Direct	Indirect	Direct	Indirect
(1) Feeders.....	9	9	7	16
(2) Lehrs.....	7	8	9	8
(3) Stackers.....	5	1	1	1
(4) Escalator Buck.....	1	2	1	0
(5) Shaping Mach.....	2	2	8	4
(6) Refractories.....	3	0	6	0
	27	22	32	29
	49		61	

	1929		Total	
	Direct	Indirect	Direct	Indirect
(1) Feeders.....	11	48	27	73
(2) Lehrs.....	12	8	28	24
(3) Stackers.....	0	3	6	5
(4) Escalator Buck.....	1	0	3	2
(5) Shaping Mach.....	3	2	13	8
(6) Refractories.....	2	0	11	0
	29	61	88	112
	90		200	

Of the 73 applications which have been cited as "indirect protection" of feeders, 50 are directed to suction gathering machines and are aimed at the development of the Knox-O'Neill machine, Owens, Hillman, Roirant, Etc.; 6 are directed to the forced feed and down suction (Hartford process) developed by Rowe and Lorenz, which method, if developed, or a modification thereof, might offer some competition in the future with our present feeders; 6 are directed to possible improvements in the "stream feed" and 4 to other feeding methods. Two cases are directed to electric feed, and the remaining 5 cases to possible modification of gob feed.

The remaining 23 cases may be classified as follows:

Electric Melting.....	2 cases.
Forming ware by rolling.....	1 "
Our new experimental tank.....	1 "
Rotary melting.....	3 "
Shallow melting.....	9 "
Sheet glass.....	1 "
Tubing and Cane production.....	6 "

23

There is no sound ground for criticism of the Patent Department in filing the cases which have been filed during 1927, 1928, and 1929. Of course, some few of the cases filed have turned out, and may hereafter turn out, to be of less value than was expected. The reasons are two-fold.

(1) The failure of a device, as the H. machine, to make a prominent place in the art, or the physical development of the art away from the particular invention.

(2) The practice which is sometimes followed in the Patent Department of filing "light" cases without going to the expense of a complete preliminary investigation of patentability. This policy is believed sound. It is as cheap to file the application as it is to make the complete investigation.

General.—These examples all seem to lead to the conclusion that the only safe thing is to go to the limit in covering at once all inventions that have a fair appearance value, by patent applications, regardless of whether we can actually at that time figure any definite income return therefrom.

Hartford-Empire has very little "selling expense", as such item is ordinarily known. We spend very little on advertising and practically nothing on salesmen in this country.

SUMMARY

(1) *Hartford, a Development Concern.*—Hartford-Empire is mainly a development and servicing company for the glass industry. It has made its success by doing such work thoroughly and with a view to the changing future.

(2) *A Changing Industry.*—The glass industry is rapidly changing, in equipment and in business conditions. A development status, effective now, will be obsolete in a few years.

(3) *Suppose We Stopped Development.*—We could, indeed, stop development now and perhaps pay larger dividends—for a while. But in a few years Hartford would be superseded by a more progressive concern, and our sources of income rapidly dwindle.

(4) *Effect On Our Licensees.*—Half the industry are our licensees. They dislike paying royalties. They would stop paying on any good excuse. The main thing that holds them in line is the prospect of our future developments. If we ceased to develop—

(a) We would, as stated above, lose in a few years, the main sources of our income.

(b) We would almost at once, be deserted by many of our licensees. The larger combines would start their own development departments.

(5) *Patent Protection.*—Unless we thoroughly protect ourselves by patents, we will be developing chiefly for the benefit of others, and will reap little return ourselves.

(6) *Basis of Our Stock Value.*—Our stock is selling now at prices far beyond its true value on its present return. That high price is fixed by men familiar with the industry because they believe in our long distance policy, and that that policy will secure for us the future.

(7) *Means of Keeping Our Position.*—To maintain that valuable position we must develop and experiment in advance. The normal development period is three years. Unless our foresight covers at least that period, some one else who does will be ready when we are not, and will take our business.

(8) *Research.*—The "research department" is now a part of large business where the "art" is changing. For example, General Electric Company. Costs and profits are not the ruling considerations in such departments. They are directed at an unknown future. The glass industry has an unknown future and we must meet it.

EXHIBIT No. 126

Mr. R. H. LEVIS,
Illinois Glass Company, Alton, Illinois.

DEAR UNCLE HARRY: I attended the regular meeting of the Board of Directors of the Hazel-Atlas Glass Company in Wheeling on Tuesday of last week, which meeting followed their annual stockholders' meeting that was held in the afternoon of the same day. There were very few stockholders present. The meeting was well conducted and all features that required any explanation were explained fully. The existing Board of Directors was reelected. Immediately following the stockholders' meeting there was an organization meeting of the new Board and the old officers were re-elected, except that Mr. McNash was also elected Chairman of the Board, as their by-laws require a Chairman of the Board as well as a President.

Their capital expenditures, being particularly large at Clarksburg for equipping an additional furnace, were likewise approved, and the condition of their business and their earnings were discussed at length. They earned for the month of February \$144,851.17, as compared with \$222,240 for the same month last year. The difference in the earnings was largely accounted for by the decline in shipment of fruit jars and fruit jar caps during the early months of this year. I am satisfied that their prospects for the next few months are such that they will comfortably earn their dividend requirements. Their cash position is good, as usual, with a total of cash and securities of \$6,845,475 after deducting a reserve to bring the securities slightly below their present market value.

Because of the recent publicity given Owens-Illinois and our investment in Hazel-Atlas in a letter read into the Congressional Record of March 8th by Mr. Borah, I advised Mr. McNash that it would probably be desirable for me to resign as a member of their Board at either their April meeting or their July

meeting, and we discussed the advisability of having Mr. George Quay, Secretary of the Company, elected in my place, with the understanding that he would be representing us and that I would receive through him the same type of information I now receive as a Director. I will see you in the meantime and we will have a chance to discuss just what should be done in this connection.

Sincerely,

(Signed) WILLIAM.

W. E. Levis.
April 1, 1935.

This is a true copy of a document found in the files of the former Illinois Glass Company, Alton, Illinois.

Certified:

F. G. MORFOOT,
Ass't Secy.—Owens-Illinois Glass Co

EXHIBIT No. 127

[Compiled by Department of Justice staff from data taken from files of Owens-Illinois Glass Co.]

Owens-Illinois Payments to and Receipts from Hartford-Empire Company

Year	Royalties paid to Hartford	Payments received from Hartford	Year	Royalties paid to Hartford	Payments received from Hartford
1924.....		\$22, 830	1932.....	\$271, 173	\$389, 208
1925.....		125, 379	1933.....	526, 543	716, 698
1926.....		215, 915	1934.....	542, 297	877, 003
1927.....		263, 703	1935.....	585, 347	750, 859
1928.....		284, 805	1936.....	758, 632	none
1929.....	\$106, 630	391, 850	1937.....	811, 127	none
1930.....	176, 302	385, 601	Total.....	3, 962, 921	4, 815, 093
1931.....	184, 870	391, 235			

EXHIBIT No. 128

[From files of Hartford-Empire Company]

Office of the President.

OWENS-ILLINOIS GLASS COMPANY,
TOLEDO, OHIO, January 13, 1933.

[Written across letter. Devlin X8.]

Mr. F. GOODWIN SMITH,
Hartford-Empire Company, Hartford, Connecticut.

MY DEAR GOODWIN: Referring to Mr. Northend's letter of January 10th regarding the persistent letters he has received from Mr. E. C. Devlin, I am replying to you rather than to him because I feel that you should know that the old Northern Glass Company plant never was operated successfully and that I do not think we should be at all concerned regarding their thoughts of resuming operation.

We are in splendid shape to take care of Milwaukee trade from our Streator, Illinois, plant, and while I want to keep posted from time to time about people who inquire for licenses for the manufacture of beverage bottles, I think the position that you are taking—that there is at present considerable over-production in the industry—should be maintained in replies to similar requests.

Sincerely,

BILL.

W. E. Levis

EXHIBIT No. 129

[From files of Owens-Illinois Glass Co.]

OWENS-ILLINOIS GLASS COMPANY,
Toledo, Ohio.

DEAR SIR: I have under contemplation the erection of a Glass Factory with a view to manufacturing a line of goods in keeping with the requirements of such retail entities as Woolworth et al. I understand that you and Hartford-Empire

control the fabricating machinery incidental to the equipping of a plant for the output of such products and that it is necessary to arrive at terms with you before such machinery is obtainable.

I would therefore appreciate hearing from you and being advised as to the course I should pursue, initially.

Very truly yours,

[s] A. L. ROMINE,
Barr Bldg., Washington, D. C.

JUNE 8, 1935.

EXHIBIT No. 130

[From files of Owens-Illinois Glass Co.]

AUBREY L. ROMINE,
Barr Bldg., Washington, D. C.

DEAR SIR: Referring to your communication of June 8th, this company is engaged in the manufacture and sale of glass containers, but we are not licensors of glass making machinery. We do construct certain glass forming mechanisms, but such equipment is for use in our own factories exclusively. We are unable, therefore, to render the service which you require.

Yours very truly,

LEGAL & PATENT DEPARTMENT,
_____, Assistant Secretary.

JUNE 17, 1935.

E. F. Martin:c

EXHIBIT No. 131

[From files of Owens-Illinois Glass Co.]

JUNE 25, 1934.

Mrs. LEN SMITH,
960 S. Oxford Ave., Apt. 325, Los Angeles, Calif.

DEAR MADAM: Your letter of June 14th addressed to our Chicago Sales Office has been referred to this Department.

For the past several years we have not built the Owens Machines for use outside our own Company, and we regret, therefore, that we are unable to furnish you with particulars concerning this type of bottle building mechanism.

Yours very truly,

LEGAL & PATENT DEPARTMENT,
_____, Assistant Secretary.

EFMartin
C

EXHIBIT No. 132

[From files of Owens-Illinois Glass Co.]

DECEMBER 10, 1934.

SPARKS CONSTRUCTION CO. INC.,
R. C. A. Building, 30 Rockefeller Plaza, New York City.

GENTLEMEN: Referring to your communication of November 30, this company does not manufacture glass making machinery for use outside its own plants.

Yours very truly,

LEGAL & PATENT DEPARTMENT,
_____, Assistant Secretary.

EFMartin
P

EXHIBIT No. 133

[Copy]

LETTER OF WM. E. LEVIS, TO R. H. LEVIS, AUGUST 2, 1932.

This is a true copy of a document found in the files of the former Illinois Glass Company, Alton, Illinois.

Certified.

_____,
Ass't. Secy., Owens-Illinois Glass Company.

WILLIAM E. LEVIS

P. O. Box 1035, Toledo, Ohio.

AUGUST 2, 1932.

Mr. R. H. LEVIS,
Illinois Glass Consolidated Corporation,
Alton, Illinois.

Dear Uncle HARRY: The two matters that I talked with Edwin about in Chicago the other day that I think are of extreme interest to the Illinois Glass Corporation are the attached proposition that I received from Mr. Gordon, C. Kidder, Peabody & Company, to purchase a block of our Owens-Illinois 5% debentures of 1939, and some negotiations that I have had recently with a Mr. I. T. Axton regarding the possibility of the Illinois Company's making an investment in the common stock of the Hazel-Atlas Glass Company, as well as a former negotiation that I had with some other New York people with the thought of the Illinois Company's purchasing some of the convertible preferred stock of the Thatcher Manufacturing Company.

Mr. McAdoo was in Toledo to spend a day with me last week and I talked with him regarding this matter. He seemed interested in going along with the Illinois Company in making a purchase of both Hazel-Atlas Glass Company common and Thatcher Manufacturing Company preferred, if the Illinois Company were to be interested in either of these propositions.

As I see the situation now, it appears that we are on the eve of straightening out the Hartford patent situation. Hazel-Atlas has come in and taken a license, and yesterday the Knox Glass Company agreed to come in, pay back damages, and take a license. In so doing they have withdrawn from the Miller Feeder Users Defense Association, and other Miller feeder users have expressed their willingness to come in and take a Hartford license if Knox and Hazel-Atlas took a license from Hartford. The only important manufacturers who remain out of Hartford's licensing plan are Ball Brothers and the Root Glass Company. We are negotiating with both of these companies and I am quite confident that they will come in if all of the other feeder operators come in, if for no other reason than to protect fruit-jar licensing, as well as to curtail the licensing of beverage bottle manufacturers.

With the plans we now have, there is certain to be a curtailment of the promiscuous manufacture of milk bottles on nonlicensed feeders, which will result in our company's and the Thatcher Company's securing a greater proportion of the available milk-bottle business. This should stabilize the price and increase the earnings of the Thatcher Company. In a recent talk with Mr. Mandeville he advised that they have on hand sufficient cash and Government securities to retire all of their preferred stock and still have adequate working capital for the operation of their business. The stock is \$3.50, \$50.00 par value preferred, convertible into common at \$55.00. It is selling at approximately \$25.00, thereby yielding 14%.

The Hazel-Atlas common is selling as outlined in the attached memoranda prepared by Frank Morfoot and other data that I have accumulated from time to time that is interesting.

Mr. Gordon called me on the telephone this morning and advised that he would be willing to make us a definite offer of 85 for \$500,000.00 par value of Owens-Illinois 5% debentures of 1939, and after I talked with him he said that if the bond market improved he might be willing to go as high as 90.

The thought that I want to put up to you for your consideration is:

Do you think it would be a good plan for the Illinois Glass Corporation to consider selling \$250,000.00 par value of its Owens-Illinois 5% debentures at a price of 90, take the proceeds of this sale, and make an investment in the common stock of the Hazel-Atlas Glass Company at a price of approximately \$40.00 per share, and a smaller investment in the preferred stock of the Thatcher Manufacturing Company at, say \$25.00 per share, investing roughly \$150,000.00 in Hazel-Atlas common and \$50,000.00 in Thatcher preferred?

If you are at all interested in this thought, will you read the attached papers and return them to me with your comments. Should your letter indicate that you would like to go into the matter further, I would be pleased to meet you with Edwin in Chicago and work out further details of the proposition.

Edwin is willing for us to make this type of an investment, for he feels as I do, that the Illinois Glass Corporation amounts substantially to an investment trust in the glass industry, and that if we gradually increase our investment in such firms as Hazel-Atlas and Thatcher to a point where we secure representation

in their companies, we will have a better idea of the possible future of our investments in the industry as a whole, and thus probably become a more dominant factor in the glass container industry than any other investor in it.

Mr. McAdoo feels that the thought is a good one and that his people would be interested in going along with us on a joint account basis. He would not want to be identified with the purchase in any way and would want to feel that we would represent their investment so long as they cared to have us do so.

I promised Mr. McAdoo that when you had finished with the attached papers I would forward them to him, so that he would not have to gather the same information. Will you please, therefore, send them to me with a copy of your reply.

Edwin had a chance to look over the attached papers when I was in Chicago, and therefore I am not sending a duplicate set to him, although I am sending him a copy of this letter so that he will be familiar with what I have written you.

Sincerely,

(Signed) WILLIAM.

W. E. Levis

EXHIBIT No. 134

[Compiled by Department of Justice staff from patent data furnished by Hartford-Empire Company]

APRIL 12, 1930.

Mr. Wm. E. LEVIS.

STATUS OF PATENT INFRINGEMENT SUITS NOW PENDING

SUITS BROUGHT BY HARTFORD ON FEEDER PATENTS

Following the settlements arrived at between Hartford, The Owens Bottle Company, Tucker, Reeves & Beatty, and William J. Miller, Hartford was able to get a number of applications out of interference and to issue patents upon them during the winter of 1925-26, and immediately thereafter (spring of 1926) suits were brought by Hartford against Obear-Nester, Nivison-Weiskopf, Keans-Gorsuch, and the Lamb Glass Company, as follows—

I. St. Louis Suits

1. *Hartford-Empire vs. Obear-Nester* (1st suit), filed in the U. S. District Court in St. Louis, April 1926. This suit was decided by Judge Faris, October 1938, who held both patents valid and infringed, except as to the first ten claims of the Peiler patent, which he found invalid because functional. Appealed to the U. S. Circuit Court of Appeals for the 8th Circuit, which affirmed the Lower Court in an opinion filed February 24, 1930. Obear-Nester stand enjoined from using the plunger feeder which they formerly employed. Steps to extend the injunction to their air-vacuum feed are being considered (see below).

The patents sued upon in the above case were—

Steimer	No. 1,564,909	December 8, 1925
Peiler	No. 1,573,742	February 16, 1926.

The Steimer patent relates only to plunger feeders. The Peiler patent listed is known as the phase change patent, and may apply to any gob feeder, whether or not it employs a plunger.

At the time this first Obear-Nester suit was filed, defendant was using a plunger feeder, but some months later changed to an air-vacuum pressure feeder without any plunger, designed by Stuckey. When these facts developed, Hartford filed another suit against Obear-Nester, as follows—

2. *Hartford-Empire vs. Obear-Nester* (2d suit), filed in the U. S. District Court, St. Louis, February 25, 1929, charging infringement of the following—

Peiler	No. 1,405,936	February 7, 1922
"	No. 1,662,436	March 13, 1928
"	No. 1,662,437	March 13, 1928
Ferngren	No. 1,677,436	July 17, 1928.

Hartford's efforts to get a trial in this case have not as yet been successful. However the trial is now expected to take place early next fall.

II. CINCINNATI SUIT

Hartford-Empire vs. Nivison-Weiskopf, filed in the U. S. District Court in Cincinnati, April, 1926, charging infringement of the same two patents, to Steimer No. 1,564,909, and Peiler No. 1,573,742, that were involved in the first Obear-Nester suit in St. Louis. Later a supplemental bill was filed to bring in a third patent—to

Peiler No. 1,589,304 June 15, 1926

The single claim of this third patent relates to the vertical adjustability of the shears with relation to the orifice.

This Cincinnati suit (involving the above three patents) was tried last June before Judge Hickenlooper, who in October, 1929, filed an opinion in favor of Hartford on the Peiler phase change patent, but finding the Steimer and the Peiler shear adjustment patent invalid. This decision has been appealed to the U. S. Circuit Court of Appeals for the 6th Circuit, and will probably be argued before that court this spring.

Judge Hickenlooper's decision on the Peiler phase change patent was particularly noticeable in that he held the first ten claims of the patent valid and infringed, notwithstanding the decision of Judge Faris in St. Louis (subsequently affirmed by the St. Louis Court of Appeals), followed by the decision of Special Master Jones in the Columbus suits (see below), finding these first ten claims invalid as functional. It now remains for the Court of Appeals at Cincinnati to decide, among other questions, whether it will follow Judge Hickenlooper or the St. Louis courts in respect to these claims.

III. COLUMBUS SUITS

1. *Hartford-Empire v. Kearns-Gorsuch*, filed in the U. S. District Court in Columbus, May, 1926, charging infringement of the same patents, to Steimer No. 1,564,909, and Peiler No. 1,573,742, that were involved in the Pittsburgh and Cincinnati suits.

Subsequently a supplemental Bill of Complaint was filed, adding two more patents—

Peiler	No. 1,589,304	June 15, 1926.
Peiler	No. 1,631,107	May 31, 1927.

The first of these is the patent on shear height adjustment which was also introduced into the Cincinnati case, against Nivison-Weiskopf. The last mentioned patent is what is known as the "whittling" patent. It involves the shaping of the gob by adjusting the relative movements of the plunger and shears.

2. *Hartford-Empire vs. Lamb Glass Company*, filed in the U. S. District Court in Columbus, charging infringement of the same patents, to Steimer No. 1,564,909, and Peiler No. 1,573,742, and patents to—

Soubier	No. 1,574,709	February 23, 1926
Ferngren	No. 1,574,739	February 23, 1926

These patents relate to the revolving plunger. The Peiler "whittling" patent No. 1,631,107 was later introduced into the Lamb case also by a supplemental bill.

Subsequently both of these Columbus suits were assigned to Hon. Berne Jones, as Special Master, to hear the evidence and report his findings to the Court, with recommendations as to the proper decree to be entered.

After hearing the evidence, Master Jones, in May 1929, handed down decisions in both of these Columbus cases. In both cases the Peiler phase change patent No. 1,573,742, was found valid and infringed, except as to the first ten claims which, following Judge Faris of St. Louis, were held invalid as functional.

The Steimer patent No. 1,564,909, and the Peiler "whittling" patent No. 1,631,107 were found not to be infringed by either the Kearns-Gorsuch or the Lamb feeders.

In the Kearns-Gorsuch suit, the Peiler shear height adjustment patent No. 1,589,304 was held limited and not infringed.

In the Lamb case, the Soubier patent was found valid and infringed. The Ferngren patent was found not to be infringed.

Both sides filed exceptions to the Master's report, and after various delays imposed by the Court, these exceptions were argued before Judge Hough in February of the present year. As yet he has not handed down a decision on those arguments, and he has intimated his intention not to make any decision until after the Court of Appeals at Cincinnati has decided the Kearns-Gorsuch case. This would

be unfortunate, but there is no way of forcing the hand of a Federal Judge who for any reason chooses to hold back his decisions.

Hartford's lawyers felt that Hazel-Atlas should be held parties privy to the Kearns-Corsuch case, and bound by the decision to be rendered as to the four patents involved in that case, but Hartford sought to attack H-A directly and did so by a suit in Pittsburgh, listed below.

3. *Hartford-Empire vs. Lamb Glass Company* (2d suit), filed in Columbus last month, charging infringement of Peiler patent No. 1,655,391, dated January 23, 1928 (see below).

IV. PITTSBURGH SUIT

Hartford-Empire vs. Hazel-Atlas, filed in the U. S. District Court in Pittsburgh, in 1928, charging infringement of Peiler patent No. 1,655,391, dated January 3, 1928.

We generally looked upon this Peiler patent as Hartford's best bet. It was supposed to broadly cover the use of a plunger in such a manner as to bring about the shaping of the gob to fit the blank mold. The case was tried before Judge Gibson, and Hartford's lawyers seemed well satisfied with the record made up. They were greatly disappointed when Judge Gibson handed down his decision, in February of this year, finding the claims of this Peiler patent so limited as not to be infringed by the Hazel-Atlas feeder.

Hartford has taken its appeal of Judge Gibson's decision to the U. S. Circuit Court of Appeals for the 3d Circuit, sitting in Philadelphia, and the appeal is expected to come up for argument next fall. Mr. Byrnes, the lawyer who argued the case for Hartford before Judge Gibson, and who is regarded as the leading patent lawyer in the Pittsburgh district and 3d Circuit, expressed himself as fairly confident that the decision of Judge Gibson would be reversed.

Our own feeling is that Mr. Byrnes is over optimistic in his view. While Judge Gibson's decision indicates a considerably mistaken attitude on his part, particularly as to the part played by Peiler in the revolution of the industry brought about by the introduction of the gob feeder, we deem his decision, taken as a whole, to be convincingly phrased and difficult to upset. We would regard the chances of reversal no better than one to three.

V. BUFFALO SUIT

Hartford's lawyers, still believing in the merits of the Peiler plunger patent, No. 1,655,391, dated January 3, 1928, notwithstanding Judge Gibson's decision, recommended the filing of two additional suits in other districts, charging infringement of this same patent. These suits include the second Lamb case, already referred to, filed during March of this year in Columbus, and the suit of—

Hartford-Empire v. Reed Glass Company, filed last month in the U. S. District Court in Buffalo.

If the trial of either of these suits should result in a decision materially different from that rendered by Judge Gibson, it is believed that the U. S. Supreme Court will listen favorably to a writ of certiorari on conflicting decisions rendered on this patent.

Suits Against Knox-O'Neill Machine

These include—

1. *Owens-Illinois v. O'Neill Machine Company and Frank O'Neill*, filed last November in the U. S. District Court in Toledo, charging infringement of Soubier patent No. 1,705,341, dated March 12, 1929.

An essential feature of this Soubier patent, upon which the charge of infringement is based, is the transfer of the parison from the blank mold table to the blow mold table of a two-table forming machine. At the time the suit was brought, O'Neill was making his transfer by the use of a cam which caused the neck mold to travel with the blow mold about the center of the blow table during the transfer period, following the Soubier movement in this respect very closely.

But in view of the charge of infringement made in this suit, O'Neill changed the form of his cam governing the travel of the neck mold during transfer, and the question of whether O'Neill's new transfer movement will infringe Soubier's claims, is much more serious. However, the present case will be tried out on O'Neill's old construction, and Mr. C. B. Belknap expresses the opinion that we have a fifty-fifty chance of winning on this issue. He asserts, furthermore, that a favorable decision on this issue would be helpful in forcing the patent against O'Neill's new construction of transfer cam.

Defendant's answer in this case has been filed, and Mr. Belknap will ask to have the case set down for trial as soon as defendant's time for taking depositions under the rule has expired. This will be within a few days, and it is hoped to secure a trial in June or the early fall, accordingly as the engagements of the Court will permit.

2. *Hartford-Empire v. Carr-Lowrey*, filed last month in the U. S. District Court in Baltimore, charging infringement of Cox patent No. 1,212,189, dated January 16, 1917. So far as we are advised, the answer in this case has not yet been filed.

Litigation Expenses

As to all of Hartford's suits on feeder patents—at St. Louis, Cincinnati, Columbus, Pittsburgh, and Buffalo—this company is making material contributions towards Hartford's expenses by way of credits against royalties coming to us from Hartford under feeder patent agreements.

But the two suits against the O'Neill machine, which being a suction machine, outside or "licensed inventions" as defined by our General License agreement with Hartford of 1924, are being brought independently by this company on the one hand, and by Hartford-Empire on the other, without any division of expenses.

PATENT & LICENSE DEPARTMENT.

Henry W. Carter
EP

—————

"EXHIBIT No. 135," introduced on p. 534, is on file with the committee.

—————

"EXHIBIT No. 136," introduced on p. 534, is on file with the committee.

—————

"EXHIBIT No. 137," introduced on p. 534, is on file with the committee.

—————

"EXHIBIT No. 138," introduced on p. 534, is on file with the committee.

—————

"EXHIBIT No. 139," introduced on p. 534, is on file with the committee.

—————

"EXHIBIT No. 140," introduced on p. 534, is on file with the committee.

—————

"EXHIBIT No. 141," introduced on p. 534, is on file with the committee.

EXHIBIT No. 142

[Copy of telegram from D. S. Quay, vice president, Hazel-Atlas Glass Co., to Department of Justice]

DECEMBER 13, 1938.

Mr. C. L. TERREL,
Department of Justice, Washington, D. C.

Dear Mr. TERREL: You called me at my home last evening and asked that I furnish you by telegraph today, a record of payments made by this company to the Hartford-Empire Company, together with a comparative record of amounts paid by Hartford-Empire to this company.

Our telegram this morning, I trust, arrived in such form as to permit you to readily pick out the information you require.

In confirmation of the figures given in that message, we submit the following:

Amount of royalty paid to Hartford-Empire Company by The
Kearns-Gorsuch Bottle Company, a former subsidiary of this
company, for the years 1919 to 1927, inclusive..... \$265, 138. 50

A record of the parent company's transactions show—

Year	Amounts paid to Hartford-Empire	Amounts received from Hartford-Empire
1932.....	\$217,899.95	\$180,404.05
1933.....	664,164.49	715,798.15
1934.....	828,465.94	877,003.58
1935.....	920,869.53	1,006,687.67
1936.....	1,139,316.08	1,305,317.79
1937.....	1,240,958.62	1,523,634.69
1938 (9 Mos.).....	759,266.36	919,815.01
Total.....	5,770,940.97	6,528,660.94

We trust the foregoing record is in sufficient detail to fit in with your needs and fully answers your request.

Yours very truly,

G. S. QUAY,
Vice-President and Secretary.

"EXHIBIT No. 143," introduced on p. 452, is on file with the Committee.

EXHIBIT No. 144

[From files of Hazel-Atlas Glass Co.]

(Personal)

SEPTEMBER FIRST, 1932.

Mr. WILLIAM E. LEVIS,
Post Office Box 1035, Toledo, Ohio.

DEAR WILLIAM: Your letter of August 31st is in connection with Root, and so on.

Referring to that part in connection with Hazel-Atlas, enclosed is a working copy of our Assets and Liabilities statement as of July 23rd. These figures are, of course, subject to audit, as they are prepared by our own accounting department.

I hope you do not let this out of your own hands. It is all right to give your Illinois Company directors information from it, but I would not like for them to have in their possession one of our work sheets.

Since July 23rd we borrowed one million dollars for the Hartford-Empire transaction. Since then we have paid off that obligation by selling some of our short term Treasury's and Fourth Liberty 4¼% Bonds, on which we have a profit. I will be glad to answer any questions in connection with this statement.

Thank you very much for information about Root. You certainly have things progressing in fine shape and I hope you get your wishes concluded fairly soon.

About Ball, I really don't have any additional views. This Company, however, is willing to go pretty far, as I indicated in New York, to give Ball what he wants as long as that want does not actually cramp our style. I don't mean by this that your Company or this Company should actually pay Ball to come in, but I believe the Hazel-Atlas Glass Company could restrict itself in such a way that there actually would not be a penalty. For instance, have the quantity of jars that we are allowed to make under the license from Hartford-Empire for fruit jars be sufficiently large to have an excess each year to accumulate to the benefit of some year when we have a repetition of the conditions that existed in 1931. I do agree with you that it is important to have Ball take a license and I will do everything I can in that direction.

With kindest regards,

Sincerely yours,

_____, President.

J. H. McNash
MF

EXHIBIT No. 145

[From files of Hazel-Atlas Glass Co.]

HARTFORD-EMPIRE Co.—804

MEMORANDUM

FEB. 9, 1933.

The Hazel-Atlas Glass Company have a non-restricted, non-exclusive license from Hartford-Empire to make fruit jars.

Negotiations are under way looking forward to Ball Brothers' taking a license.

Hartford really offered Ball the residual rights excepting as to Hazel and Owens-Illinois. Ball really wants more than that—he wants some restriction placed upon Owens-Illinois and Hazel.

Various conversations have been had on this subject between the interested parties.

During some of these conversations the atmosphere became very tense. Even questions of good faith were involved.

All these things finally came to the top Friday, February 3, in New York. Messrs. F. C. and G. A. Ball questioned me about a quarter to six on that day, in connection with the attitude of Owens-Illinois in case an agreement could be reached.

I explained my view of the thing with respect to Owens-Illinois, and why.

Apparently there was a desire on the part of Messrs. F. C. and G. A. Ball to arrive at a satisfactory situation.

As a consequence of this I was willing to change my view to some extent with respect to Hazel's position in this matter, and restrict our license to 300,000 gross per year, without any mention in the contract of any conditions modifying this amount.

Previous to this I had been insisting upon some understanding in event of an increase in the use of fruit jars for the domestic trade; or some repetition of what took place in September of 1930 in our New England territory, which might put us over our restricted license; or, a repetition of what transpired in 1931 when, by a combination of many circumstances, an unusual demand was had for domestic fruit jars.

I told Mr. F. C. and G. A. Ball it was not necessary to have these modifications in the contract as far as I was concerned, if they (Messrs. F. C. and G. A.) would permit me to tell my story to Mr. F. Goodwin Smith in their presence, inasmuch as he would have to be the umpire under the licensing arrangement, and for them to see whether my statement was correct or not.

Mr. F. Goodwin Smith came into the room. I presented my story as outlined, particularly with respect to an increase in the use of jars generally, or some recurrence in some particular territory of what happened in New England in 1930, or a repetition of 1931 generally—and the fact that the Ball Brothers had said that in these respects a very liberal interpretation should be given to our restriction.

Messrs. F. C. and G. A. Ball confirmed my understanding in Mr. F. Goodwin Smith's presence—and I am asking Mr. F. Goodwin Smith to make a record of this, certify to it, to be in his files as a part of the atmosphere, at least of this Ball situation—so that anyone following Mr. F. Goodwin Smith will know just how the situation is to be handled.

I am certifying to this record here for the same purpose.

[Certified true copy, Hazel-Atlas Glass Co.]

EXHIBIT No. 146

[From files of Owens-Illinois Glass Co.]

DECEMBER 13, 1930.

Mr. WM. E. LEVIS.

SECTION 22, GENERAL LICENSE AGREEMENT WITH HARTFORD

The following is by way of comment upon the insistence of Hartford-Empire management on the desirability of cancelling Section 22 of the General License Agreement of April 9, 1924, entered into between Hartford-Empire Company, on the one hand, and The Owens Bottle Company, on the other:

Mr. Williams has sent me copy of his letter to you of December 9 on this subject, giving the legal reasons why he believes, with Hartford, that this section should be cancelled. These are based mostly on his consideration of the Sherman

and Clayton Acts, and the possible effect of the Dill Bill, if that measure, which has already passed the Senate, should become a law. I understand that the conclusions reached by Mr. Williams in this connection are substantially those heretofore reached by Herbert Knox Smith, General Counsel for the Hartford-Empire Company.

Both lawyers have made a particular study of the so-called antimonopoly statutes, and I assume that their position is well taken.

Will, therefore, confine my views to more practical business considerations, and am disposed to urge the difficulties which Hartford is meeting in maintaining its licensing system, in the returns from which we are so largely interested.

Hartford's lack of any established patent position leaves them open to incessant complaints from their licensees, first because these feel that Hartford is not giving them sufficient protection against competitors who are using pirate feeders and machines for which they pay no royalties, second, because they feel unduly restricted in the fields of ware which they are permitted to make under Hartford's license.

As to the first, Hartford is practically helpless to do anything further than is already being done. They now have under way and are vigorously prosecuting eight different suits in five different federal jurisdictions at an expense already of nearly a million dollars (continuing at the rate of about twenty thousand dollars a month). Until some definite conclusions are handed down in these litigations by the courts of last resort, Hartford's ability to further protect its licensees must be regarded as distinctly limited.

It is only along the second line that Goodwin Smith can accomplish anything toward keeping peace in the family, and he naturally tries to do so by conceding such additional rights as seem reasonable and are imperatively demanded. But as a practical matter he is frequently embarrassed when such a question comes up, by the fact that he cannot dispose of it without referring it to the management of this company to give or refuse its consent under Section 22. Such references usually entail more or less delay in answering the licensee, and since the licensee generally has some definite immediate business in mind in asking for the enlargement of its license, much exasperation towards Hartford results even where the request is granted. And frequently, of course, it is necessary for Goodwin Smith to refuse the request, either because of our veto, or because Hartford feels bound by its relationships with other licensees.

The result undoubtedly is that Hartford's prestige with its licensees is being continually weakened, and they are likely to be faced any day with a general revolt, threats of which, couched in no uncertain terms and in the hard language of anger and disappointment, are being faced by Hartford's management almost daily. While he has made remarkably little complaint about the situation and is taking it in a sportsmanlike manner, Goodwin Smith does not hesitate to say that if we were obliged to sit with him and continually face the insistances and threats of their licensees, we would have a much greater appreciation of what they are up against.

The removal of the limitations placed on Hartford by Section 22 of our General License Agreement, if cancelled as Hartford is now requesting, will not cure the situation by a long ways, but I believe it will go a considerable distance toward easing the strain at those critical points which are otherwise so liable to result in a definite break. At least Hartford's management could then give immediate reply, yes or no, to its licensees' demands, instead of being obliged, as now, to wait to argue the situation with us.

The objection on our part to eliminating Section 22 is the fear that Hartford, once freed of our veto, might be inclined to grant licenses recklessly and without regard to the state of the market or good of the industry. Believe that this fear is much exaggerated. We have been dealing with Hartford under our 1924 agreement for more than six years now and have never found any tendency on their part to act recklessly or in disregard of basic conditions. Believe we may safely conclude that their attitude in the future will not be different.

Moreover, it seems to me, too, that we have practically come to a parting of the ways. If we are to conserve and maintain our royalty income of really half a million dollars, we must look at the licensing question from that point of view, rather than from the opposition standpoint of what the granting or extension of any particular license rights might cost us in a competitive way. I don't believe we can much longer successfully continue to straddle these divergent policies.

If Hartford's patent position had been definitely sustained as a controlling one, things would be very different, but with the public free, up to the present time, to use such practical feeder equipment as that employed today by Hazel-Atlas, Obear-Nestor, and Nivison-Weiskopf, it is very evident that Hartford is in no

position to crack the whip. On the contrary, it seems probable that the Hartford-Empire Company will be obliged more and more to adopt a conciliatory policy toward their licensees, or the latter will break loose and resort to some such outside equipment as these other competitors are now notoriously employing, without payment of royalty or limitation as to ware. Loss of income during these hard times is putting Hartford's licensees under great pressure to thus fly the coop.

Looking the facts squarely in the face, I believe that we will be in luck if Hartford's licensees continue to pay royalties at all. And since they are certainly more likely to continue if we give Hartford a free hand in placating their complaints, I deem this another cogent reason, additional to the legal one, why it would be wise to give up our veto power under Section 22 of the General License Agreement of April 9, 1924.

PATENT & LICENSE DEPARTMENT,
HENRY W. CARTER,
Vice President in Charge.

EP
cc—F. G. Smith.
L. T. Williams.

EXHIBIT No. 147

[From files of Anchor-Hocking Glass Co.]

Cable address: Emhart.

HARTFORD-EMPIRE COMPANY

Glass Working Machinery

HARTFORD, CONN., *Thursday, August 17, 1933.*

Mr. I. J. COLLINS,
President, The Hocking Glass Company, Lancaster, Ohio.

DEAR IKE: I am enclosing copy of a letter just received from Mr. F. C. Ball relative to packers' jars sold into the domestic fruit-jar field.

We discussed this in New York and you assured me that you were using every effort to keep jars out of this field.

I feel, therefore, that in fairness to you you should be advised about this complaint from Ball, as I know you won't misunderstand my sending it to you.

When you see a chance to spend a day or two with me at Lancaster, let me know and I will make every effort to fit it into my plans.

I hope everything is fine with you.

Sincerely yours,

ROGER M. ELDRÉD.

R. M. Eldred.
GP.
Enc.

EXHIBIT No. 148

[From files of Anchor-Hocking Glass Company]

BALL BROTHERS COMPANY,
Muncie, Indiana, August 15, 1933.

Mr. R. M. ELDRÉD,
Hartford-Empire Company, Hartford, Conn.

DEAR MR. ELDRÉD: Before Mr. G. A. Ball left for Europe he had some talk with you over the telephone regarding so called packers ware supplied by General Glass Company.

I enclose herewith copies of letters regarding plain, unlettered, so called packers jars, Mason fruit jar shape that fit the regular Mason fruit jar cap that are being sold for domestic use.

One of these letters is from a customer in Stevens Point regarding the so called packers jar sold from Green Bay, Wisconsin. We are informed that the General Glass Company are supplying quantities of these jars to a Green Bay jobber and that they are sold for domestic use.

Please let us know what you can do to stop this encroachment on your license agreement which prohibits the sale of these so called packers jars for domestic use.

Awaiting your reply, we remain,

Yours truly,

F. C. BALL, *President.*

GENTLEMEN: For your information, we find in our every-day experience that we are unable to sell Mason Jars in competition with other jobbers.

They are selling Quart jars for instance at \$6.65 complete, including caps and rubbers. They are getting in car after car. It is the jar the public wants.

What are we to do for the balance of the season?

We are duty bound to meet competition, compelling us to buy a car of the same jars.

We would like to hear from you with a suggestion so as to relieve the serious situation confronting us.

THE COPPS COMPANY

Wholesale Grocers

STEVENS POINT, WISCONSIN, 8-5-33.

Refer answer to: BDC: H

BALL BROTHERS,
Muncie, Ind.

GENTLEMEN: We are surely up against it on this "packer" jar situation.

We have had correspondence with you pertaining to it at various times during this season and now they are coming into Stevens Point with these jars, some of them from Green Bay, some from Milwaukee, and some from Chicago. Isn't there something that you can do to get a few, at least, to us at the right price?

Please let us know quick.

Yours truly,

THE COPPS COMPANY.

EXHIBIT No. 149

[From the files of Ball Brothers Company]

MAY 3, 1933.

MR. GOODWIN SMITH,

President, Hartford-Empire Company, Hartford, Conn.

DEAR MR. SMITH: Since writing to you yesterday regarding Three Rivers Glass Company I have been reliably informed that a Sherman, Texas, jobber is now offering to sell to the retail trade Fruit Jars for domestic use to be manufactured by the Three Rivers Glass Company under the brand name "Crack Shot." The price at which they are offering these jars is 65¢ per gross less than the same Jobber is offering "Ball Jars." This is disturbing the other jobbing customers and they want to know what we are going to do about it.

I have learned at the Owens Illinois Dallas office this morning that Three Rivers Glass Company are operating under receivership and I presume they are intending to make these "Crack-Shot" Jars.

As I wrote you yesterday Three Rivers have in stock about fifteen carloads of plain Pint and Quart Jars that fit Mason P/L caps which they have been offering to the trade for domestic use. Possibly these plain Jars are being sold in connection with the "Crack Shot" jars. At any rate I believe that you should notify them of the exclusive license rights with us and inform them that they have no right to manufacture Fruit Jars of any kind to be sold for domestic use.

This being the beginning of the Fruit Jar season these prices that are being offered by the Three Rivers Company will more than likely disturb market conditions and I trust that you will take steps at once to stop them from manufacturing jars for domestic use by the Three Rivers Company.

I am leaving Dallas this afternoon for home and will be in Muncie next Friday.

Kindly send me a copy of your letter to the Three Rivers Company and when you receive a reply from them please let me know what they have to say.

Very truly yours,

_____, *President.*

Dictd. by Mr. F. C. Ball.

I certify that this is a correct copy of the original document, with the exception of possible typographical errors.

BALL BROTHERS COMPANY,
By A. M. BRACKEN,
Assistant Treasurer.

EXHIBIT No. 151

[From files of Lynch Corporation]

[Copy]

Cable Address: EMHART

HARTFORD-EMPIRE COMPANY
Glass Working Machinery

HARTFORD, CONN., September 20, 1933.

Mr. T. G. WERBE,
President, The Lynch Corporation,
Anderson, Indiana.

DEAR MR. WERBE: This is in answer to your letter of September 13 regarding Universal and the procedure to be followed generally in granting forming machine licenses to those persons who wish to obtain forming machines from you. If Universal advised you that they had an H-E forming machine license they are evidently laboring under some misconception as to the extent of their present license. This license is merely to cover six feeders for the production of principally milk bottles.

We shall, however, send them a forming machine license sometime this week along with our form letter and such other information in regard to their particular situation as seems necessary.

As to your new contract form, I believe that Mr. Miller has now approved of it and that he will send it to you as quickly as possible, if he has not already done so.

Mr. Parham has already explained to you that we are issuing no formal licenses for existing machines and that the license for future machines is now ready.

As our general procedure for dealing with each person who wishes one of your forming machines we suggest the following:

- (1) We will send you a list of our feeder licensees and keep it revised for you.
- (2) When you get an order for a forming machine you will advise us.
- (3) If it is from a feeder licensee we shall then forward to the licensee our standard forming machine license agreement adapted to the licensee's particular field of ware. This license he is to sign and return to us.
- (4) If he is not a licensee then you will decline to furnish the machine in such language as appears proper to you under the circumstances.
- (5) If it is to a feeder licensee to whom we are sending a forming-machine license you will send your usual sales contract for execution.
- (6) When we have advised you that our forming-machine license is signed and you have a signed copy of your own contract, you can then make delivery of the machine.

The above is merely our suggestion for handling the matter. If some part of it disturbs your ordinary routine, or you believe it will harm your delivery of machines, please write us and we will settle it in some mutually satisfactory fashion.

It may take some time to get these various details ironed out, but once we get started there will not be very much difficulty about our contractual relations and those with the people who wish to use these machines.

Yours very truly,

(Signed) ARTHUR T. SAFFORD, Jr.,
Secretary.

I certify that this is a correct copy of the original document, with the exception of possible typographical errors.

LYNCH CORPORATION,
By E. PODMORE,
Assistant Secretary.

"EXHIBIT No. 152," introduced on p. 606, is on file with the committee.

EXHIBIT NO. 153

[Compiled by Federal Bureau of Investigation from certified data furnished by Hartford-Empire Co.]

Hartford-Empire Company—Analysis of Financial Statements

	1923	1924	1925	1926	1927	1928	1929
NET INCOME FROM CAPITAL EMPLOYED IN OPERATIONS (Deductions in parentheses)							
Gross Operating Income.....	\$101,391.01	\$183,216.77	\$393,765.54	\$806,587.94	\$845,855.02	\$336,041.12	\$906,315.40
Gross Operating Income.....	9,411.44		75.00			(20,704.12)	290,564.32
Gross Operating Income.....							2,568.14
Gross Operating Income.....	12,738.24	17,715.48	1,280.51	7,492.45	11,936.67	20,704.12	18,449.19
Gross Operating Income.....	(8,478.57)	(15,056.65)	(7,808.55)	(1,472.22)	(1,000.00)	(1,000.00)	(458.50)
Interest Income.....	(18,615.27)	(20,908.85)	(7,821.14)	(8,586.84)	(12,358.89)		88,313.46
Sale of Patent Rights.....							
Special Burden.....							
Interest and Miscellaneous.....	10,616.46	851.49	(1,207.59)	(4,010.36)	(4,522.87)	2,402.57	(24,050.73)
Inventory Adjustments.....	436.55	11.61					(68.70)
Fire Loss Account.....							
(Loss) or Gain on Equipment Discarded or Sold.....	(30,824.74)	7,799.03	(14,089.22)	(17,296.13)	(9,346.71)	(33,586.05)	35.82
(Loss) or Gain on Equipment Discarded or Sold.....			(426.25)	(650.00)	(5,707.80)		(4,646.72)
(Loss) or Gain on Equipment Discarded or Sold.....					(223.06)		
Hartford Fairmount Profit and Loss a/c.....							
Adjustment of Corning Machines.....	(5,444.97)						
Royalties Payable.....		3,065.99					
Undistributed Manufacturing Expense.....		(22,830.89)	(141,243.27)	(369,319.76)	(420,662.10)	1,584.50	
Adjustment of Patent Values.....		(283.75)					
Unadjusted Income Taxes—Prior Years.....				(103,070.00)	(75,000.00)	(5,923.85)	50,000.00
Refractory Costs.....						(70,478.09)	(117,333.31)
Development Work Written Off.....							(50,820.57)
Recovery or (Loss) on Bad Debts.....							
Recovery or (Loss) on Bad Debts.....							
Depreciation.....							
Depreciation.....							
Amortization of Patents.....							
Legal and Accounting.....							
Elimination of Reserve for Litigation.....							
Amortization of License Rights.....							
Infringement Damages.....							
Foreign Commissions.....							
Federal Income Tax.....							(34,130.85)
Totals.....	70,793.60	154,005.67	222,533.03	312,730.42	336,301.43	229,040.20	324,717.28

	1930	1931	1932	1933	1934	1935	1936	1937
NET INCOME OTHER THAN FROM OPERATIONS								
(Deductions in parentheses)								
Profit or (Loss) on Sale of Investments.....	(32.81)	289.06	757.82	(1,145.00)				921.88
Income From Investments.....	8,478.57	15,056.65	7,808.55	26,000.00		1,000.00	1,000.00	452.83
Income From Investments.....				1,472.22				458.50
Totals.....	8,445.76	15,345.71	8,566.37	26,347.22		1,000.00	1,000.00	1,833.31
Total Net Income.....	79,239.36	169,351.38	231,099.40	339,077.64		337,301.43	230,040.20	326,550.59
Adjustments Not Affecting Current Income: Discount or (Premium) on Preferred Stock.....	1,210.00	(4,000.00)	(5,706.00)			(2,200.00)	(8,250.00)	
Total Net Income per Hartford-Empire Co. Statements.....	80,449.36	165,351.38	225,393.40	339,077.64		335,101.43	221,790.20	326,550.59
Total Capital and Surplus Invested:								
Capital Stock, Common.....	5,220,385.68	5,220,385.68	5,220,385.68	5,245,355.68		5,257,885.68	4,252,326.36	4,260,551.36
Capital Stock, Preferred.....	752,400.00	490,200.00	860,000.00	860,000.00		750,000.00	475,000.00	
Surplus.....	3,235.31	44,877.65	127,061.72	287,956.36		451,478.12	530,701.74	606,021.49
Totals.....	5,976,020.99	5,755,463.33	6,207,447.40	6,393,342.04		6,459,363.80	5,258,028.10	4,867,172.85
Capital Employed Other Than in Operations:								
Investments.....	325,187.50	275,554.69	127,062.50	25,000.00		25,000.00	25,000.00	386,016.38
Stocks of Associated Companies.....						58,000.00	194,899.64	197,199.64
Loans and Advances to Associated Companies.....								1,250.00
Totals.....	325,187.50	275,554.69	127,062.50	25,000.00		83,000.00	219,899.64	584,466.02
Net Capital Employed in Operations.....	5,650,833.49	5,479,908.64	6,080,384.90	6,308,342.04		6,376,363.80	5,038,328.46	4,282,706.83

	1930	1931	1932	1933	1934	1935	1936	1937
NET INCOME FROM CAPITAL EMPLOYED IN OPERATIONS								
(Deductions in parentheses)								
Gross Operating Income.....	\$1,054,195.45	\$596,793.79	\$744,963.65	\$982,850.97	\$1,169,403.54	\$1,453,680.02	\$2,756,464.70	\$3,053,869.83
Gross Operating Income.....	353,627.73	352,643.05	360,492.43	309,086.57	330,712.10	346,868.59	308,205.78	333,220.88
Gross Operating Income.....	26,415.24	26,415.24	26,915.24	34,559.60			25,950.00	
Gross Operating Income.....			7,250.00	69,416.63				
Gross Operating Income.....			76,500.00					
Interest Income.....	21,818.56	21,107.14	14,074.59	8,248.56	5,674.21	3,503.74	5,712.68	3,638.27
Sale of Patent Rights.....	29,637.73	11,097.43		15,471.59	323.54	23,216.25	75,541.18	18,941.17
Special Burden.....				(26,396.29)	(28,047.66)	(33,296.31)	(34,570.11)	(53,233.19)
Interest and Miscellaneous.....								
Inventory Adjustments.....	7,301.69	(33,493.68)	(1,682.16)	3,699.53				

Hartford-Empire Company—Analysis of Financial Statements—Continued

	1930	1931	1932	1933	1934	1935	1936	1937
NET INCOME FROM CAPITAL EMPLOYED IN OPERATIONS—COD.								
(Deductions in parentheses)								
Fire Loss Account								
(Loss) or Gain on Equipment Discarded or Sold	\$ (4,454.16)	\$ (410.46)	\$ (2,867.25)	\$ (1,704.90)				
(Loss) or Gain on Equipment Discarded or Sold	(12,449.61)	(5,663.26)	(39,831.03)	(24,808.99)				
Hartford Farmount Profit and Loss a/c	34.46							
Adjustment of Corning Machines			(2,666.64)	(8,000.00)				
Royalties Payable								
Undistributed Manufacturing Expense								
Adjustments of Patent Values								
Unadjusted Income Taxes—Prior Years								
Refractory Cos's								
Development Work Written Off	(124,018.34)	(27,356.62)	36,127.15					
Recovery or (Loss) on Bad Debts	(296,746.25)	42,741.78	(4,800.41)					
Recovery or (Loss) on Bad Debts			38,684.10					
Depreciation	(47,496.33)	(52,059.18)	(47,791.74)	(42,802.66)				
Amortization of Patents	(320,721.60)	(323,936.18)	(246,050.63)	(244,040.60)				
Legal and Accounting	(457,365.05)	(403,489.41)	(416,371.77)	(426,781.89)				
Elimination of Reserve for Litigation	(4,755.42)	(2,916.84)	(16,792.20)	(2,319.18)				
Amortization of License Rights			25,000.00	(13,073.62)				
Infringement Damages								
Foreign Commissions								
Federal Income Tax	(38,526.18)	(24,677.46)	(35,093.70)	(89,313.42)				
Totals	276,443.46	176,829.80	363,225.61	573,101.90	695,278.36	836,060.28	1,559,389.64	1,798,324.59
NET INCOME OTHER THAN FROM OPERATIONS								
(Deductions in parentheses)								
Profit or (Loss) on Sale of Investments	498.15		(91,474.74)	(6,306.27)				
Income from Investments	34,368.04	51,047.54	55,213.93	70,935.55				
Income from Investments			(36,260.81)	64,629.28				
Totals	34,866.19	51,047.54	326,964.80	637,731.18	83,876.71	128,772.37	1,682,420.36	1,795,69.69
Total Net Income	311,309.65	227,877.34	326,964.80	637,731.18	689,155.07	964,832.65	1,682,420.36	1,934,120.28
Adjustments Not Affecting Current Income: Discount or (Premium) on Preferred Stock								
Total Net Income per Hartford-Empire Co., Statements	311,309.65	227,877.34	326,964.80	637,731.18	689,155.07	964,832.65	1,682,420.36	1,934,120.28

	1923	1924	1925	1926	1927	1928	1929
Total capital and surplus invested:							
Capital Stock, Common.....	4,260,551.36	4,260,551.36	4,262,651.36	4,262,651.36	4,262,921.36	4,262,921.36	4,275,421.38
Capital Stock, Preferred.....	697,131.14	984,918.10	980,682.90	1,204,414.08	1,443,566.11	1,194,510.53	1,183,95.97
Surplus.....	4,957,682.50	5,245,469.46	5,243,334.26	5,467,065.44	5,706,487.47	5,457,431.89	5,458,717.33
Totals.....							
Capital Employed Other Than in Operations:							
Investments.....	577,102.20	886,708.75	1,483,246.58	1,912,331.93	2,053,995.02	1,865,022.66	2,176,265.44
Stocks of Associated Companies.....	197,199.64	254,249.60	2,400.00	14,516.00	14,693.49	48,000.00	161,350.00
Loans and Advances to Associated Companies.....	2,000.00	2,400.00					
Totals.....	776,301.84	1,086,308.39	1,739,896.18	1,926,847.93	2,068,689.41	1,865,022.66	2,864,346.67
Net Capital Employed in Operations.....	4,181,380.66	4,159,161.07	3,503,438.08	3,540,217.51	3,637,798.06	3,544,769.04	2,594,370.66
Total Capital and Surplus Invested.....	\$5,976,020.99	\$5,755,463.33	\$6,207,447.40	\$6,393,342.04	\$6,459,363.80	\$5,238,028.10	\$4,867,172.85
Net Capital Employed in Operations.....	5,650,833.49	5,479,908.64	6,080,384.90	6,265,342.04	6,376,363.80	5,041,328.46	4,282,706.83
Total Net Income.....	79,239.36	169,351.35	231,099.40	339,577.64	337,301.43	230,040.20	326,550.59
Net Income From Capital Employed in Operations.....	70,793.60	154,005.67	222,533.03	312,730.42	336,301.43	229,040.20	324,717.28
Total Net Income as a Percent of Total Capital and Surplus Invested (percent).....	1.33	2.94	3.72	5.30	5.22	4.38	6.71
Net Income From Capital Employed in Operations as a Percent of Net Capital Employed in Operations (percent).....	1.25	2.81	3.66	4.91	5.27	4.54	7.58
Total Capital and Surplus Invested.....	\$4,957,682.50	\$5,245,469.46	\$5,243,334.26	\$5,467,065.44	\$5,409,791.70	\$5,457,431.89	\$5,458,717.33
Net Capital Employed in Operations.....	4,181,380.66	4,159,161.07	3,503,438.08	3,540,217.51	3,637,798.06	3,233,166.45	2,594,370.66
Total Net Income.....	311,309.65	227,877.34	326,984.80	637,731.18	689,155.07	1,682,420.36	1,934,120.28
Net Income From Capital Employed in Operations.....	270,443.46	176,829.80	363,225.61	573,101.90	605,278.36	1,559,589.64	1,758,324.59
Total Net Income as a Percent of Total Capital and Surplus Invested, percent.....	6.28	4.34	6.24	11.66	12.08	17.83	35.43
Net Income From Capital Employed in Operations as a Percent of Net Capital employed in Operations, percent.....	6.61	4.25	10.37	16.19	16.64	48.24	67.77

Hartford-Empire Company—Analysis of Financial Statements—Continued

Year	Total capital and surplus	Total net income or (loss)	Return on total investment	Net capital employed in operations	Net operating income or (loss)	Return on investment employed in operations
1912-1922*	\$248,954.55	(\$69,530.27)	(27.92%)	\$248,954.55	(\$69,530.27)	(27.92%)
1923	5,976,020.99	79,239.36	1.33%	5,650,833.49	70,793.60	1.25%
1924	5,755,463.33	169,351.38	2.94%	5,479,908.64	154,005.67	2.81%
1925	6,207,447.40	231,099.40	3.72%	6,080,384.90	222,533.03	3.66%
1926	6,393,342.04	339,077.64	5.30%	6,368,342.04	312,730.42	4.91%
1927	6,459,363.80	337,301.43	5.22%	6,376,363.80	336,301.43	5.27%
1928	5,258,028.10	230,040.20	4.38%	5,038,328.46	229,040.20	4.54%
1929	4,867,172.85	326,550.59	6.71%	4,282,706.83	324,717.28	7.58%
1930	4,957,682.50	311,309.65	6.28%	4,181,380.66	276,443.46	6.61%
1931	5,245,469.46	227,877.34	4.34%	4,159,161.07	176,829.80	4.25%
1932	5,243,334.26	326,964.80	6.24%	3,503,438.08	363,225.61	10.37%
1933	5,467,065.44	637,731.18	11.66%	3,540,217.51	573,101.90	16.19%
1934	5,706,487.47	689,155.07	16.64%	3,637,798.06	605,278.36	16.64%
1935	5,409,791.70	964,832.65	17.83%	3,544,769.04	836,060.28	23.59%
1936	5,457,431.89	1,682,420.36	30.83%	3,233,166.45	1,559,589.64	48.24%
1937	5,458,717.33	1,934,120.28	35.43%	2,594,370.66	1,758,324.59	67.77%
(Average) (1912-1937)	3,330,819.94	297,009.17	8.92%	2,708,064.22	270,543.94	9.99%

* Figures for the period 1912-1922 are the average yearly figures of the Hartford-Fairmont Company, as furnished by Mr. A. T. Safford, Jr., Secretary of Hartford-Empire Company. The figures for the years 1923-1937 were arrived at through analyzing the financial statements of the Hartford-Empire Company for each of the respective years.

EXHIBIT No. 154

[From files of George E. Day, Detroit, Michigan]

(Cable address "Emhart.")

HARTFORD-EMPIRE COMPANY,
Hartford, Connecticut, February 1, 1936.Mr. GEORGE E. DAY,
27th Floor, David Stoll Building,
Detroit, Michigan.

DEAR MR. DAY: Since first receiving a report from Mr. Schwenzfeier relative to your proposition for a glass plant in Detroit, we here at Hartford have been giving the matter some serious thought.

Possibly we do not have the full story but from what we know of the glass industry in general being greatly overcapacitated,¹ it does not seem to us feasible nor advisable to increase the tonnage that already exists.

If you and your associates care to come to Hartford, we will be more than pleased to get your story first-hand, but doubt whether our ideas will be altered.

Sincerely yours,

(Signed) A. M. PEASE,
HARTFORD-EMPIRE CO.

AMP/J

[Written in margin: How come in view of users statement?]

¹Word "overcapacitated" underlined.

EXHIBIT No. 155

[From files of Obear-Nester Glass Company]

JUNE 29, 1935.

LYNCH CORPORATION,
Anderson, Indiana.
(Attention: Mr. Werbe, President)

DEAR MR. WERBE: We are contemplating the installation of two or three additional machines and we are writing you to find out if you are in a position to furnish us with two or three of your late model Lynch 10 Bottle Forming Machines.

If so, we would like to know just what price you will charge us for these machines and about how soon you can make shipment after you receive our order.

We understand that you have made some changes over the early model Lynch 10 Machines, which you have furnished to the Glass Manufacturers and we would

like for you to advise if you are in a position to furnish us machines with these latest improvements or your regular Model 10 Lynch machines.

Trusting that you can advise us at once relative to the above, we beg to remain
Yours very truly,

WAN/mhc
Copy

OBEAR NESTER GLASS COMPANY,
By _____, *Vice President.*

EXHIBIT No. 156

[From files of Lynch Corporation]

LYNCH CORPORATION,
Anderson, Ind., U. S. A., July 1, 1935.

OBEAR-NESTER GLASS COMPANY,
East St. Louis, Illinois.
(Attention Mr. W. A. Nester.)

GENTLEMEN: Replying to your letter of June 29, the price on the Model 10 Lynch machine at the present time is \$12,000.00 F. O. B. Anderson. This is the same price as previously quoted, although the cost of manufacture has been advancing. We are quoting this price, therefore, subject to change without notice.

There has been a few changes and improvements to the machine since the original model, such changes and improvements are of course incorporated in the current models.

Regarding time of shipment, this depends upon conditions at time order is received. Just at present we are extremely busy and have more than thirty machines of different models on order. We could probably make delivery of two or three Model 10 machines the latter part of August if ordered at the present time. We are usually in position to make shipment within two to three weeks from receipt of order.

The Lynch Model 10 machine, as well as all other models, require a forming machine license as the machines include a number of patented features on which the patents are held or owned by others.

If any additional information is wanted, do not hesitate to write us.

Yours very truly,

LYNCH CORPORATION,
T. C. WERBE, *Pres.*

TCW:EP
Copy

EXHIBIT No. 157

[From files of Lynch Corporation]

WM. A. RODENBERG, *Vice-President*
W. A. NESTER, *Vice-President*

JOSEPH K. NESTER, *President*

D. X. BAGBY, *Secretary*
PAUL S. ABT, *Treasurer*

Make all remittances to East St. Louis, Ill., office.

Quotations are subject to immediate acceptance or change without notice and subject to prior sale.

We do not agree to warrant as to exactness of capacity the articles to be delivered, nor that they shall be equal to any particular sample but agree only that the goods shall be merchandise for the general use for which they are designed.

We agree to take all reasonable care and diligence in fulfilling orders, but shall not be responsible for non-delivery caused by or resulting from acts of Providence, strikes, lockouts, fires, floods, or any accident or contingency beyond our control.

OBEAR-NESTER GLASS Co.

Manufacturers of Flint, Green, and Amber Bottles

FACTORY EAST ST. LOUIS, ILL.

East St. Louis, Ill., July 3, 1935.

LYNCH CORPORATION,
Anderson, Indiana.
(Attention: T. C. Werbe, Pres.)

GENTLEMEN: We have your letter of July 1, quoting us on your Model 10 Lynch machine and we note your remarks.

We would like to have you advise us, if it is necessary for us to take out a license for the forming machines as a prerequisite to your shipping us the Lynch Model 10, or if you will ship us the Lynch Model 10 machines, before we secure a

forming machine license. We would also like to know too, if these conditions will apply on your shipping us your other Lynch Model machines, such as the LA or "R" type, as it is possible that we will require some additional LA and "R" type machines.

Trusting to hear from you promptly, we beg to remain

Yours very truly,

OBEAR-NESTER GLASS COMPANY,
(Signed) By W. A. NESTER.

WAN/mhc

I certify that this is a correct copy of the original document, with the exception of possible typographical errors.

LYNCH CORPORATION,
By E. PODMORE,
Assistant Secretary

[Copy]

EXHIBIT No. 158

[From files of Lynch Corporation]

JULY 8, 1935.

OBEAR-NESTER COMPANY,
East St. Louis, Illinois.

(Attention Mr. W. A. Nester.)

GENTLEMEN: Replying to your letter of July 3rd, we would not care to make shipment of any Lynch machines until you secure a forming machine license as to do so would only result in litigation. All models of Lynch machines, including the "LA" and "R" type, require a forming machine license.

Yours very truly,

LYNCH CORPORATION,
T. C. WERBE, *Pres.*

TCW:EP

I certify that this is a correct copy of the original document, with the exception of possible typographical errors.

LYNCH CORPORATION,
By E. PODMORE,
Assistant Secretary.

[Copy]

EXHIBIT No. 159

[From files of Corning Glass Works]

HARTFORD-EMPIRE COMPANY,
Hartford, Conn., November 20, 1937.

Mr. AMORY HOUGHTON,
*President, Corning Glass Works,
Corning, N. Y.*

DEAR AM: Eldred and Pease spent a day at Lancaster with Ike and Bill Fisher. Ike was in a pretty ugly mood about a number of things and, incidentally, he had samples of various kinds of baking ware and hard glass ware which had a bluish tint such as your top-of-the-stove ware.

All these samples had been made up by hand, and he had named this line of Ware Fryrock.

Ike is going to defy us all in this kind of ware and use the same tactics that he is now using when he defies H-E Co. on forming machine patents.

Sincerely,

GOODWIN.

P. S. Bart Arkell writes me as follows: "Do you happen to know who is the President of the Steuben Glass Company? I notice the Yale University Press are offering for sale a most interesting book entitled "General Von Steuben" and I should like to present it as a Yale gift to the President of the Steuben Glass Company, particularly if he is a Harvard man."

[Stamped: Certified true copy. Corning Glass Works.]

"EXHIBIT No. 160," introduced on p. 657, is on file with the committee.

"EXHIBIT No. 161," introduced on p. 661, is on file with the committee.

EXHIBIT No. 162

[From files of Hartford-Empire Company]

[Copy]

Mr. Safford.

HARTFORD-EMPIRE COMPANY,
Hartford, Conn., March 31, 1936.

LYNCH CORPORATION,
Anderson, Indiana.
(Attention: Mr. T. C. Werbe.)

GENTLEMEN: From time to time we have discussed with you some misunderstandings which have apparently arisen as to the interpretation of the license contract between our companies, and we feel that it is worth while to sum up the matter in a letter.

We understand that it has been suggested that no glassware manufacturer can obtain forming machines from the Lynch Corporation unless such manufacturer is also a feeder licensee of the Hartford-Empire Company. Of course, this is not what the contract says and is not what was intended. As is clearly stated in Section 3 of the Forming Machine Agreement, the Lynch Corporation has a license to deliver forming machines coming under Hartford-Empire patents "to any person or concern that has obtained from Hartford a license under Hartford's *forming machine* inventions to use such forming machines." We think it will be desirable that both you and ourselves make this plain whenever the question arises as to who can obtain forming machines coming under Hartford patents.

As we now understand it, you are unwilling to eliminate from the Forming Machine Agreement the provisions of Section 8, page 9, to the effect that Hartford is required to pay license fees to Lynch for any excess of its annual production of patented forming machines over a prescribed capacity. We regret that you cannot agree with us that Section 8 should be removed from the contract but, of course, if you are not willing to have it removed, we can do nothing about it.

This letter will also confirm our understanding that the Supplemental Agreement, dated August 23, 1933, between Hartford and Lynch, is no longer in effect.

Adding to what we have already stated above, we wish to assure you that it is our policy to negotiate licenses for Lynch forming machines with any reputable glassware manufacturer, whether or not such manufacturer desires a feeder license from the Hartford-Empire Company.

Very truly yours,

HARTFORD-EMPIRE COMPANY,
R. D. BROWN.

RDB/PET.

Co Messrs. F. G. Smith, W. J. Belknap, and Safford.

 SUPPLEMENTAL DATA

The following statement was entered in the record at hearings on February 28, 1939, and is printed herewith in connection with the testimony of Alfred Reeves, see text, p. 303:

EXHIBIT No. 302

AUTOMOBILE MANUFACTURERS ASSOCIATION, INC.

Statement of Income and Expense for the Year Ended June 30, 1938

Income:		
Dues Received from Members.....		\$539, 473. 97
Interest from Securities Owned.....		16, 604. 04
Miscellaneous.....		9, 436. 18
		<hr/>
Total Income (Carried Forward).....		565, 514. 19
Expenses:		
Administrative Expenses:		
Salaries, Mileage and Fees, Directors and Members Meetings.....	\$34, 363. 11	
		<hr/>
Departmental Expenses:		
Motor Truck Department.....	11, 086. 39	
Patent Department—General Expense....	19, 963. 95	
Patent Classification.....	29, 929. 00	
Traffic Department.....	14, 960. 34	
Legislative Information Department....	24, 960. 78	
Research Department.....	19, 573. 90	
Facts and Figures Publication.....	3, 369. 57	
Export Department.....	16, 124. 62	
Information Bureau.....	7, 690. 51	
Manufacturers' Committee.....	19, 193. 36	
Public Relations Department.....	27, 276. 59	
Statistical Division.....	22, 289. 63	
		<hr/>
Total, Departmental Expenses.....	216, 418. 64	
Legal Expense.....	33, 323. 15	
Highways.....	51. 53	
International Road Congress.....	5, 782. 48	
		<hr/>
General Expenses:		
New York Office.....	51, 583. 15	
Washington Office.....	54, 423. 09	
Detroit Office.....	30, 275. 09	
Unemployment Insurance Tax.....	6, 773. 37	
Group Insurance.....	2, 345. 25	
Social Security Tax.....	1, 530. 40	
Equipment Purchased.....	1, 814. 97	
General Expense.....	3, 966. 31	
Depreciation—Library.....	18, 157. 89	
		<hr/>
Total, General Expenses.....	170, 869. 52	
Contributions:		
Automotive Safety Foundation—Harvard University Traffic Bureau.....	54, 250. 00	
National Highway Users Conference.....	40, 000. 00	
Society of Automotive Engineers:		
Safety Work.....	\$12, 500. 00	
Standardization Work.....	7, 500. 00	
Fuel Research.....	3, 102. 48	
		<hr/>
	23, 102. 48	
National Industrial Conference Board....	1, 500. 00	
Highway Education Board.....	10, 000. 00	
American Standards Association.....	500. 00	
Economic Policy Committee.....	12, 500. 00	
		<hr/>
Total Contributions.....	141, 852. 48	
		<hr/>
Total expenses.....		602, 660. 91
Excess of Expenses over Income for the Year.....		37, 146. 72

The following statement was entered in the record at hearings held February 28, 1939, and is printed at this point in connection with the glass patent story herein:

GLASS CONTAINER ASSOCIATION
OF AMERICA
19 WEST 44TH STREET
NEW YORK

See what you Buy—Buy in Glass

JANUARY 9, 1939.

Honorable JOSEPH C. O'MAHOONEY,
*Chairman, Temporary National Economic Committee,
Room 231, Apex Building, Washington, D. C.*

DEAR SIR: In compliance with your statement at the close of the Glass Container Industry hearing on patents—that “each member of the Committee is desirous of seeing this problem from every possible aspect, and will therefore welcome comment and suggestions and reports from any interested person”—we hereby submit for the record an economic survey of the industry covering the past period of from nine to eighteen years. The survey has been submitted to the Department of Justice. Copies are enclosed for members of the Committee.

This survey covers the history of the companies and plants in the industry for the past eighteen years. Some of the points disclosed are as follows:

1. At the present time there are 45 companies having 90 plants.
2. The 90 plants are located in 17 different states. Over 50% are located in towns of under 25,000 population.
3. During the eighteen years, 22 new companies have come into the industry; 29 companies have gone out of business; and 28 companies have consolidated with other companies.
4. From 5 to 28 companies compete for each line of containers.
5. Active capacity is nearly 50% in excess of any past demand. In 1937, the industry's best year, it operated at 67.43% of active capacity. For the past ten years the average operation has been approximately 55% of active capacity. Licensed capacity, or potential capacity, is much greater than this.
6. In the last ten years the small companies have increased their volume 86%; the medium-sized companies, 89%; while the five largest companies have increased their volume 40%. The industry shows an increase of 52%.
7. Milk bottles cost the dairies approximately $\frac{1}{10}$ of a cent for each trip that a bottle makes.
8. Since 1929 average selling prices have been reduced approximately 13%.
9. Since 1929 the labor cost per unit has increased approximately 13%.
10. In 1929, 27.7 employees were required to produce 1,000 gross of bottles in one week. In 1937, 29.4 employees were required to produce 1,000 gross of bottles in one week.
11. From 1929 to 1937, hours of work per week have been reduced from 49.7 to 41, or 17%. Wages per hour have been increased from \$0.501 to \$0.645, or 29%. Wages per week have been increased from \$24.88 to \$26.42, or 6%. The number of employees has increased from 17,173 to 28,293, or 65%.
12. Employment has been continuous. Labor is organized. Labor relations are good. The industry has been practically free from labor disturbances during the past nine years. Less than one hour out of every 8,000 working hours has been lost due to strikes, or approximately .012%.

Respectfully submitted.

(Signed) E. G. ACKERMAN,
E. G. Ackerman,
GLASS CONTAINER ASSOCIATION OF AMERICA.

EGA:MM

EXHIBIT No. 303

SURVEY OF THE GLASS CONTAINER INDUSTRY

Submitted to The Temporary National Economic Committee by the Glass Container Association of America, 19 West 44th Street, New York, N. Y., December 5, 1938

INDEX

	Page ¹
Definition of Scope of Study.....	1
History of Individual Companies with Plant Location Since 1920.....	2-10
Name and location of Glass Container Manufacturers.....	11-12
Explanation of Glass Container Industry Classifications.....	13-15
Relative Importance of Each Class of Product.....	16-18
Companies Producing and Shipping Each Class of Product.....	19-24
Relationship of Shipments to Capacity Since 1928.....	25-30
Progress of Individual Companies Since 1928.....	31-33
Trend of Prices in the Glass Container Industry.....	34-35
Employment and Wages.....	36-41
Glass Container Association Activities.....	42-44

¹ Pagination of original document is carried throughout in brackets on left margin.

THE GLASS CONTAINER INDUSTRY

[1]

DEFINITION

The Glass Container Industry may be defined as the manufacturers who produce and sell glass bottles, glass jars, and glass accessories for glass bottles and jars.

SCOPE OF INDUSTRY

The industry at the present time consists of forty-five known companies, operating ninety factories. The factories are located in seventeen different States. The location of these factories may be listed as follows:

California.....	6	Oklahoma.....	7
Florida.....	1	Pennsylvania.....	18
Illinois.....	6	South Carolina.....	1
Indiana.....	11	Tennessee.....	1
Kansas.....	1	Texas.....	2
Maryland.....	4	Washington.....	1
Mississippi.....	1	West Virginia.....	11
New Jersey.....	6		
New York.....	7		
Ohio.....	6		

DESCRIPTION OF INDUSTRY

The products of the industry are produced primarily by automatic machine. Production by the hand method is continued by five companies, though four of these five also produce by automatic equipment. Production by the hand method has not been included in this study except where Census figures have been used, and where it has been impossible to separate this production from automatic production.

The value of hand production has been less than 2% of the total value of glass containers during this period. The value in 1929 amounted to approximately \$1,800,000.00, and the value in 1937 amounted to approximately \$1,000,000.00.

[2] HISTORY OF INDIVIDUAL COMPANIES, WITH PLANT LOCATION SINCE 1920

On the accompanying chart we show the operating history of the individual companies in the Glass Container Industry, and the operation of individual plants since the year 1920.

Change in name of company has been noted in the year when this change occurred.

Plants such as the Busch Glass Mfg. Company in St. Louis, and William Franzen & Son, Inc., in Milwaukee, that specialized in beer bottles, and went out of business shortly after 1920, have not been included in this study. Also, such plants as the V. & S. Bottle Company of Roulette, Pa., and the General Glass Works of Ridgway, Pa., that operated intermittently by the hand method during the early part of this period, have not been included. Also, such plants as the Puritan Glass Company of Massillon, Ohio, and the Birmingham Glass Works of Tarrant, Ala., that operated only a few months, have not been included. The study does include all plants that operated for an extended period during these eighteen years.

In the plant history, we have indicated the period of operation, and the period of idleness, and have indicated the approximate size of all plants, or companies, that went out of business, or that were dismantled.

In reviewing this history it should be noted that individual plants have generally increased in size, and have materially increased their productive capacity.

In summary, the number of plants has been reduced from 102 to 90. During the later period there has been an increasing number of idle plants, so that at the present time there are 78 plants operating, and 12 plants that are idle.

In 1920, there were 80 different operating companies. During the 18-year period, 22 new companies have come into the industry, 29 companies have gone out of business, and 28 companies have been consolidated with other companies in the industry, so that in 1938 we have a net of 45 companies.

For the greater part, plants in the industry are located in small towns, and represent the principal industry in these small towns. The location of present plants may be summarized by size of town as follows:

[3] Number of Plants:	Population
27	Under 10,000.
22	10,000 to 25,000.
15	25,000 to 50,000.
7	50,000 to 100,000.
5	100,000 to 250,000.
5	250,000 to 500,000.
9	Over 500,000.

[4] *Glass container industry—Individual company history and plant location since 1920*
 Legend: O—Operating; I—Idle; X—Out of business or dismantled; A—Size less than 100,000 gross per year; B—Size more than 100,000 gross per year.

State and city	Name of company	1920	1921	1922	1923	1924	1925	1926	1927	1928	1929	1930	1931	1932	1933	1934	1935	1936	1937
Arkansas: Ft. Smith	Zenor Bottle Co.	O	O	O	O	O	XA	X	X	X	X	X	X	X	X	X	X	X	X
California:																			
Long Beach	Long Beach Glass Co.	O	O	O	O	O	O	O	O	O	O	O	O	O	O	O	O	O	O
Los Angeles	Letchford Glass Co.	O	O	O	O	O	O	O	O	O	O	O	O	O	O	O	O	O	O
Los Angeles	Maywood Glass Co.	O	O	O	O	O	O	O	O	O	O	O	O	O	O	O	O	O	O
Los Angeles	McLaughlin Glass Co.	O	O	O	O	O	O	O	O	O	O	O	O	O	O	O	O	O	O
Los Angeles	Southern Glass Co.	O	O	O	O	O	O	O	O	O	O	O	O	O	O	O	O	O	O
Los Angeles	West Coast Glass Co.	O	O	O	O	O	O	O	O	O	O	O	O	O	O	O	O	O	O
Oakland	Hazel Atlas Glass Co. of Calif.	O	O	O	O	O	O	O	O	O	O	O	O	O	O	O	O	O	O
San Francisco	Pacific Coast Gl. Co.	O	O	O	O	O	O	O	O	O	O	O	O	O	O	O	O	O	O
Florida: Jacksonville	Florida Glass Co.	O	O	O	O	O	O	O	O	O	O	O	O	O	O	O	O	O	O
Illinois:																			
Alton	Illinois Glass Co.	O	O	O	O	O	O	O	O	O	O	O	O	O	O	O	O	O	O
Chicago Heights	Chicago Heights Co.	O	O	O	O	O	O	O	O	O	O	O	O	O	O	O	O	O	O
Danville	Headley Glass Co.	O	O	O	O	O	O	O	O	O	O	O	O	O	O	O	O	O	O
East St. Louis	Obear Nester Gl. Co.	O	O	O	XA	O	O	O	O	O	O	O	O	O	O	O	O	O	O
Freeport	W. T. Rawleigh	O	O	O	O	O	O	O	O	O	O	O	O	O	O	O	O	O	O
Hillsboro	Schram Glass Co.	O	O	O	O	O	O	O	O	O	O	O	O	O	O	O	O	O	O
Streator	American Bottle Co.	O	O	O	O	O	O	O	O	O	O	O	O	O	O	O	O	O	O
Streator	Thatcher Mfg. Co.	O	O	O	O	O	O	O	O	O	O	O	O	O	O	O	O	O	O
Indiana:																			
Dunkirk	Hart Glass Mfg. Co.	O	O	O	O	O	O	O	O	O	O	O	O	O	O	O	O	O	O
Evansville	Graham Glass Co.	O	O	O	O	O	O	O	O	O	O	O	O	O	O	O	O	O	O
Gas City	Illinois Glass Co.	O	O	O	O	O	O	O	O	O	O	O	O	O	O	O	O	O	O
Indianapolis	Fairmount Glass Works	O	O	O	O	O	O	O	O	O	O	O	O	O	O	O	O	O	O
Lapel	Sterling Glass Co.	O	O	O	O	O	O	O	O	O	O	O	O	O	O	O	O	O	O
Logansport	Graham Bros.	O	O	O	O	O	O	O	O	O	O	O	O	O	O	O	O	O	O
Marion	Standard Glass Co.	O	O	O	O	O	O	O	O	O	O	O	O	O	O	O	O	O	O
Marion	Upland Flint Bottle	O	O	O	O	O	O	O	O	O	O	O	O	O	O	O	O	O	O
Muncie	Ball Brothers Co.	O	O	O	O	O	O	O	O	O	O	O	O	O	O	O	O	O	O
Muncie	Hemingray Glass Co.	O	O	O	O	O	O	O	O	O	O	O	O	O	O	O	O	O	O
Terre Haute	North Baltimore Glass	O	O	O	O	O	O	O	O	O	O	O	O	O	O	O	O	O	O
Terre Haute	Root Glass Co.	O	O	O	O	O	O	O	O	O	O	O	O	O	O	O	O	O	O
Terre Haute	Turner Glass Co.	O	O	O	O	O	O	O	O	O	O	O	O	O	O	O	O	O	O
Terre Haute	Woodbury Glass Co.	O	O	O	O	O	O	O	O	O	O	O	O	O	O	O	O	O	O
Winchester	Diamond Glass Co.	O	O	O	O	O	O	O	O	O	O	O	O	O	O	O	O	O	O
Kansas: Caney	Southern Glass Co.	O	O	O	O	O	O	O	O	O	O	O	O	O	O	O	O	O	O
Louisiana: Bastrop	Southern States Bottle Co.	O	O	O	O	O	O	O	O	O	O	O	O	O	O	O	O	O	O
Maryland:																			
Baltimore	Buck Glass Co.	O	O	O	O	O	O	O	O	O	O	O	O	O	O	O	O	O	O
Baltimore	Carr-Lowry Gl. Co.	O	O	O	O	O	O	O	O	O	O	O	O	O	O	O	O	O	O
Baltimore	Maryland Glass Corp.	O	O	O	O	O	O	O	O	O	O	O	O	O	O	O	O	O	O
Baltimore	Swindell Bros. Inc.	O	O	O	O	O	O	O	O	O	O	O	O	O	O	O	O	O	O

[5]

[6]

Huntington.....																		I
Paden City.....																		I
Parkersburg.....																		I
St. Albans.....																		O
Wheeling.....																		X
																		X
Total, Operating Plants.....	102	102	101	101	101	97	95	92	85	86	80	80	80	74	80	77	77	78
Total, Idle Plants.....			1	2	2	2	2	5	7	5	7	7	14	15	14	17	16	12

- | | |
|------------------|---------------------------|
| 1 Gl. Cont. Inc. | 6 Gen'l Gl. |
| 2 Ill. Pacific. | 7 Anchor Hocking. |
| 3 Owens Ill. | 8 Bot. caps. |
| 4 Ball Bros. | 9 Knox. |
| 5 Owens Bot. Co. | 10 Thatcher Mfg. |
| 6 Foster Forbes. | 11 Turner Bros. |
| 7 Gl. Blocks. | 12 Connelly Gl. |
| | 13 Knox Gl. B. |
| | 14 Ill. Glass. |
| | 15 Bot. caps. |
| | 16 Knox. |
| | 17 Capstan Gl. |
| | 18 Hazel Atlas. |
| | 19 Olean Gl. |
| | 20 Berney Bond. |
| | 21 Ball Bros. |
| | 22 Liberty Gl. |
| | 23 Penn Glass Co. (Knox). |
| | 24 Monongah. |
| | 25 Amer. Gl. Works. |

[11] NAME AND LOCATION OF GLASS CONTAINER MANUFACTURERS

The following are the names and location of companies included in the Glass Container Industry.

Companies located west of the Rocky mountains are noted separately, and are treated separately throughout the greater part of this study. Statistical records are kept by the Glass Container Association for each group and since the history for the western division of the industry is somewhat different from the eastern it seems advisable for the greater part to show them as separate groups.

- Anchor-Hocking Glass Corp., Lancaster, Ohio.
 Armstrong Cork Company, Whitall-Tatum Company Division, Millville, N. J.
 Ball Brothers Company, Muncie, Ind.
 Brockway Glass Company, Brockway, Penna.
 Buck Glass Company, Baltimore, Md.
 Carr-Lowrey Glass Company, Baltimore, Md.
 Chattanooga Glass Company, Chattanooga, Tenn.
 Diamond Glass Company, Royersford, Penna.
 Fairmount Glass Works, Inc., Indianapolis, Ind.
 Florida Glass Manufacturing Co., Jacksonville, Fla.
 Foster-Forbes Glass Co., Marion, Ind.
 Gayner Glass Works, Salem, N. J.
 Glenshaw Glass Company, Inc., Glenshaw, Penna.
 J. T. & A. Hamilton Co., Pittsburgh, Penna.
 Hart Glass Manufacturing Co., Dunkirk, Ind.
 Hazel-Atlas Glass Company, Wheeling, W. Va.
 Alexander H. Korr & Company, Sand Springs, Okla.
 *Knox Glass Bottle Company, Knox, Penna.
 *Knox Glass Bottle Company, Jackson, Miss.
 *Marienville Glass Company, Marienville, Penna.
 *Metro Glass Bottle Company, Jersey City, N. J.
 *Oil City Glass Company, Oil City, Penna.
 *Pennsylvania Bottle Company, Sheffield, Penna.
 *Wightman Glass & Bottle Mfg. Co., Parkers Landing, Penna.
 Lamb Glass Company, Mt. Vernon, Ohio.
 Laurens Glass Company, Laurens, S. Car.
 Liberty Glass Company, Sapulpa, Okla.
 Maryland Glass Corporation, Baltimore, Md.
 Obear-Nester Glass Company, East St. Louis, Ill.
 Olean Glass Company, Olean, N. Y.
 [12] Owens-Illinois Glass Company, Toledo, Ohio.
 Pierce Glass Company, Port Allegany, Penna.
 F. E. Reed Glass Company, Rochester, N. Y.
 Sterling Glass Company, Chicago, Ill.
 Swindell Brothers, Baltimore, Md.
 Thatcher Manufacturing Company, Elmira, N. Y.
 Tygart Valley Glass Company, Washington, Penna.
 Universal Glass Products Company, Parkersburg, West Va.
 T. C. Wheaton Company, Millville, N. J.

COMPANIES LOCATED ON THE WEST COAST

- Glass Containers, Inc., Los Angeles, Calif.
 Hazel-Atlas Glass Company of Calif., Oakland, Calif.
 Latchford-Marble Glass Company, Los Angeles, Calif.
 Maywood Glass Company, Los Angeles, Calif.
 Northwestern Glass Company, Seattle, Wash.
 Owens-Illinois Pacific Coast Co., San Francisco, Calif.

[13] EXPLANATION OF GLASS CONTAINER INDUSTRY CLASSIFICATIONS

The products of the industry are classified in the following groups:

1. NARROW NECK—FOOD CONTAINERS

Includes: Catsup, chili sauce, cider (noncarbonated) clam juice, coffee (liquid), condiments, cruetts, fountain concentrates, grape juice (noncarbonated), logan-

*Consolidated in one table for G. C. A. statistics.

berry juice (noncarbonated), orange juice (noncarbonated), oyster cocktail, pectin, prune juice (noncarbonated), salad dressing, spices (liquid), syrup, table sauces, tomato juice, vinegars.

2. WIDE MOUTH—FOOD CONTAINERS AND JARS

Includes: Anchovies, candies, caviar, celery salt, chop suey (not sauce), coffee-crushed fruits, horse radish, jams, maraschino cherries, marshmallow cream, mayonnaise, mince meat, meats, mushrooms (not sauce), mushroom spawn, mustard, olives, onions, peanut butter, pickles, preserves, relish, salad dressing (w/m jars only), salt and pepper style shakers (for packers use), sea foods, soups, spaghetti, sugar, vegetables.

Also includes any other Wide Mouth Jars or containers which are used by packers for condiments and food products not specifically mentioned in the group of products herein listed.

3. PRESSED—FOOD CONTAINERS

Includes: Pressed tumblers, but does not include domestic jelly glasses.

4. PRESSURE AND NON-PRESSURE WARE

Includes: Chocolate-milk drinks (beverage style containers), ginger ale, water (carbonated), water (noncarbonated), siphon bottles, soda, soft drinks (non-carbonated).

Special note should be taken that this does not include fruit juices, beer, wines, cordials, champagne, gin, whiskey, or any kind of alcoholic liquor or beverage.

5. BEER BOTTLES

Includes: All bottles to be used as containers for beer, ale, porter, and all other alcoholic cereal beverages bottled under carbonation. This not only covers the generally accepted beer style container but also any other style of container used for products as explained under this caption.

[14]

6. LIQUOR WARE

Includes: Benedictine, bitters, brandies, champagne, cordials, Creme de Menthe, flaska (for alcoholic beverages), gins, rum, vermouth, whiskeys, wines.

Also includes all alcoholic liquors and beverages except beer, porter, ale and other alcoholic cereal beverages bottled under carbonation.

7. MEDICINAL AND TOILET WARE

Includes: Acid bottles (not incl. 5- and 10-gal. carboys), argyrol, bath salts, bay rum, brilliantine, capsules, castor oils, chemicals, citrate of magnesia, cod liver oil, cosmetics, cuticle oil, cuticle remover, deodorants, dentifrice, druggists' presc. ware, embalming fluid, essential oils, face creams, flavoring extracts, hair tonics, insecticides, iodine, liniments, lotions, mercurochrome, mouth wash, nail polish, nursers, perfumes, peroxides, pharmaceuticals, proprietary medicines, pomades, sachet, serums, shampoos, shaving cream, smelling salts, soaps, spraying machine jars, sterilizers, tablets, talcum powders, toilet preparations, toilet waters, vases, witch hazel.

Also included are any other containers manufactured for products not specifically mentioned in this list which, however, because of their general character belong to this group.

8. GENERAL PURPOSE CONTAINERS

Includes: Ammonias, artists' colors, battery jars, bluing, carboys (5 gal.), carboys (10 gal.), cement, cleaning fluids, dyes, fire extinguishers, floats, floor wax, flower pots, glue, inks, linseed oil, mucilages, oil dispensing bottles, oil stove reservoirs, pantry jars (not packers ware), paints, polishes, refrigerator bottles (not packers ware), sewing machine oil, shakers (for table use only), shellac, soap dispensing globes, stain, table cream jars (1 oz. and 2 oz.), turpentine, varnish, washing fluids.

Includes all other miscellaneous items which cannot be classified in any of the other eight classifications.

9. MILK BOTTLES

Includes: Cottage-cheese jars, cream bottles, milk bottles, milk shape liquid malted milk or chocolate milk bottles used by dairies.

The following containers should be excluded from the milk-bottle classification: Narrow neck or soda style bottles used by dairies or soft drink bottlers for liquid malted milk or chocolate drinks. (See beverage.) Infants' nursing bottles. (See medicinals and toilets.) Jars used for malted milk or other milk products in powdered or granular form. (See wide mouth.) 1-oz. and 2-oz. table-cream jars. (See general purpose.) Mushroom spawn bottles. (See wide-mouth food.)

[15]

10. DOMESTIC FRUIT JARS

To include all wide-mouth containers to be used for home preserving of fruits and vegetables. Does not include packers ware for packaging commercial products and which can be reused in the home for domestic purposes after the package has been emptied.

11. DOMESTIC JELLY GLASSES

To include all jelly glasses to be used for home packing. Does not include packers ware for packaging commercial products.

[16] RELATIVE IMPORTANCE OF EACH CLASS OF PRODUCT AND THE COMPANIES PRODUCING EACH CLASS OF PRODUCT

On the following chart we show the relative importance of each class of product to the industry's total shipments. Alternate years have been taken, starting with the year 1929. Eastern and Western classifications are shown on separate charts.

Following the charts on product classification we show the companies that produced and shipped each class of product during 1937.

Pressed ware companies actually should include the Libbey Glass Company, Corning Glass Works, Federal Glass Company, Bartlett-Collins Company, and the United States Glass Company, who produce this general classification of product, either pressed, or pressed and blown. Their figures are not included because it is impossible to differentiate between tumblers used as containers and tumblers used for drinking glasses.

It should be noted that Knox Glass Associates on the second chart represents the following individual companies:

Knox Glass Bottle Company, Knox, Pa.
 Knox Glass Bottle Company, Jackson, Miss.
 Marienville Glass Company, Marienville, Pa.
 Metro Glass Bottle Company, Jersey City, N. J.
 Oil City Glass Company, Oil City, Pa.
 Pennsylvania Bottle Company, Sheffield, Pa.
 Wightman Glass & Bottle Mfg. Co., Parkers Landing, Pa.

Companies in the East that ship West, are not included in the chart of companies producing in the West. Many companies ship West, but Western companies do not ship East.

[17] SHIPMENTS BY CLASSES OF WARE, SHOWING RELATIVE IMPORTANCE OF EACH, EAST OF ROCKY MOUNTAINS

	1929		1931		1933		1935		1937	
	Gross	Per-cent	Gross	Per-cent	Gross	Per-cent	Gross	Per-cent	Gross	Per-cent
Total Industry.....	32, 163, 053	100.00	30, 031, 566	100.00	31, 274, 360	100.00	35, 408, 394	100.00	46, 811, 107	100.00
Narrow Neck Food Containers.....	2, 636, 622	8. 20	2, 402, 348	8. 00	2, 077, 191	6. 64	2, 775, 710	7. 84	3, 145, 211	6. 72
Wide Mouth Food Containers & Jars.....	5, 322, 881	16. 55	5, 447, 541	18. 14	5, 969, 041	19. 09	7, 064, 178	19. 95	8, 517, 158	18. 19
Pressed Food Ware	1, 243, 655	3. 87	774, 403	2. 58	470, 029	1. 50	468, 223	1. 32	433, 902	. 93
Pressure & Non-Pressure Ware.....	4, 564, 853	14. 19	3, 558, 868	11. 85	1, 475, 347	4. 72	1, 259, 139	3. 56	2, 832, 539	6. 05
Beer Bottles.....	-----	-----	-----	-----	4, 184, 833	13. 38	1, 211, 245	3. 42	3, 809, 436	8. 14
Liquor Ware.....	-----	-----	-----	-----	-----	-----	5, 244, 493	14. 81	7, 398, 112	15. 80
Medicinal & Toilet Ware.....	12, 848, 574	39. 95	11, 696, 196	38. 95	11, 957, 265	38. 23	11, 954, 025	33. 76	14, 415, 888	30. 80
General Purpose Containers.....	1, 882, 932	5. 85	1, 794, 593	5. 97	2, 268, 928	7. 24	2, 141, 807	6. 05	2, 568, 646	5. 49
Milk Bottles.....	2, 406, 087	7. 48	2, 072, 094	6. 90	1, 769, 968	5. 66	1, 941, 829	5. 48	2, 419, 631	5. 17
Domestic Fruit Jars	1, 165, 986	3. 63	2, 174, 041	7. 24	1, 027, 884	3. 29	1, 273, 422	3. 60	1, 201, 691	2. 56
Domestic Jelly Glasses.....	91, 463	. 28	111, 482	. 37	73, 874	. 24	74, 323	. 21	68, 893	. 15

[18] SHIPMENTS BY CLASSES OF WARE, SHOWING RELATIVE IMPORTANCE OF EACH, WEST COAST GROUP

	1929		1931		1933		1935		1937	
	Gross	Per-cent	Gross	Per-cent	Gross	Per-cent	Gross	Per-cent	Gross	Per-cent
Total Industry.....	1, 602, 843	100.00	1, 481, 942	100.00	1, 774, 387	100.00	2, 219, 682	100.00	3, 364, 995	100.00
Narrow Neck Food Containers.....	183, 930	11. 48	120, 946	8. 16	192, 849	10. 87	308, 300	13. 89	427, 436	12. 70
Wide Mouth Food Containers & Jars.....	519, 986	32. 44	510, 290	34. 43	466, 952	26. 32	608, 483	27. 41	814, 407	24. 20
Milk Bottles, Domestic Fruit Jars, Pressed Food Ware.....	156, 970	9. 79	187, 270	12. 64	158, 819	8. 95	197, 038	8. 88	238, 066	7. 07
Pressure & Non-Pressure Ware.....	263, 672	16. 45	132, 910	8. 97	55, 304	3. 12	68, 003	3. 06	234, 082	6. 96
Beer Bottles.....	-----	-----	-----	-----	308, 462	17. 38	123, 954	5. 58	503, 971	14. 98
Wine Bottles.....	-----	-----	-----	-----	-----	-----	-----	-----	209, 658	6. 23
Liquor Ware.....	-----	-----	-----	-----	-----	-----	416, 896	18. 78	327, 751	9. 74
Medicinal & Toilet Ware.....	428, 019	26. 70	452, 929	30. 56	517, 600	29. 17	466, 107	21. 00	574, 690	17. 08
General Purpose Containers.....	50, 266	3. 14	77, 597	5. 24	74, 401	4. 19	30, 901	1. 40	34, 934	1. 04

[19] COMPANIES PRODUCING AND SHIPPING EACH CLASS OF PRODUCT DURING 1937

EASTERN MANUFACTURERS

- Narrow Neck Bottle Companies:
- Anchor-Hocking Glass Corporation.
 - Ball Brothers Company.
 - Brockway Glass Company.
 - Chattanooga Glass Company.
 - Diamond Glass Company.
 - Fairmount Glass Works, Inc.
 - Foster-Forbes Glass Company.
 - Glenshaw Glass Company.
 - Hart Glass Manufacturing Company.
 - Hazel-Atlas Glass Company.
 - Knox Glass Associates, Inc.
 - Maryland Glass Corporation.
 - Obear-Nester Glass Company.
 - Owens-Illinois Glass Company.
 - F. E. Reed Glass Company.
 - Sterling Glass Company.

- Thatcher Manufacturing Company (Olean).
 Three Rivers Glass Company.
 Tygart Valley Glass Company.
 Whitall-Tatum Company (Armstrong Cork).
- Pressed Ware Companies:
 Anchor-Hocking Glass Corporation.
 Hazel-Atlas Glass Company.
- Wide Mouth Bottle Companies:
 Anchor-Hocking Glass Corporation.
 Ball Brothers Company.
 Brockway Glass Company.
 Buck Glass Company.
 Carr-Lowrey Glass Company.
 Chattanooga Glass Company.
 Diamond Glass Company.
 Fairmount Glass Works, Inc.
 Florida Glass Manufacturing Company.
 Foster-Forbes Glass Company.
 Hart Glass Manufacturing Company.
 Hazel-Atlas Glass Company.
 Knox Glass Associates, Inc.
 Laurens Glass Works, Inc.
 Maryland Glass Corporation.
 Owens-Illinois Glass Company.
- [20] F. E. Reed Glass Company.
 Sterling Glass Company.
 Thatcher Manufacturing Co. (Olean).
 Three Rivers Glass Company.
 Tygart Valley Glass Company.
 Whitall-Tatum Company (Armstrong Cork).
- Pressure & Nonpressure Ware Containers:
 Anchor-Hocking Glass Corporation.
 Ball Brothers Company.
 Buck Glass Company.
 Chattanooga Glass Company.
 Diamond Glass Company.
 Fairmount Glass Works, Inc.
 Florida Glass Manufacturing Company.
 Glenshaw Glass Company.
 J. T. & A. Hamilton Company.
 Hazel-Atlas Glass Company.
 Knox Glass Associates, Inc.
 Laurens Glass Works, Inc.
 Maryland Glass Corporation.
 Obear-Nester Glass Company.
 Owens-Illinois Glass Company.
 Pierce Glass Company.
 F. E. Reed Glass Company.
 Three Rivers Glass Company.
 Whitall-Tatum Company (Armstrong Cork).
- Beer Bottle Companies:
 Anchor-Hocking Glass Corporation.
 Ball Brothers Company.
 Brockway Glass Company.
 Fairmount Glass Works, Inc.
 Florida Glass Manufacturing Company.
 Glenshaw Glass Company.
 Hart Glass Manufacturing Company.
 Hazel-Atlas Glass Company.
 Knox Glass Associates, Inc.
 Maryland Glass Corporation.
 Obear-Nester Glass Company.
 Owens-Illinois Glass Company.
 Pierce Glass Company.
 F. E. Reed Glass Company.
 Swindell Brothers, Inc.
 Three Rivers Glass Company.
 Whitall-Tatum Company (Armstrong Cork).

- [21] Liquor Ware Companies:
 Anchor-Hocking Glass Corporation.
 Ball Brothers Company.
 Brockway Glass Company.
 Buck Glass Company.
 Carr-Lowrey Glass Company.
 Diamond Glass Company.
 Fairmount Glass Works, Inc.
 Foster-Forbes Glass Company.
 Glenshaw Glass Company.
 J. T. & A. Hamilton Company.
 Hart Glass Manufacturing Company.
 Hazel-Atlas Glass Company.
 Knox Glass Associates, Inc.
 Maryland Glass Corporation.
 Obear-Nester Glass Company.
 Owens-Illinois Glass Company.
 Pierce Glass Company.
 F. E. Reed Glass Company.
 Sterling Glass Company.
 Swindell Brothers, Inc.
 Thatcher Manufacturing Co. (Olean).
 Whittall-Tatum Company (Armstrong Cork).
- Medicinal & Toilet Preparation Companies:
 Anchor-Hocking Glass Corporation.
 Ball Brothers Company.
 Buck Glass Company.
 Brockway Glass Company.
 Carr-Lowrey Glass Company.
 Chattanooga Glass Company.
 Diamond Glass Company.
 Fairmount Glass Works, Inc.
 Foster-Forbes Glass Company.
 J. T. & A. Hamilton Company.
 Hart Glass Manufacturing Company.
 Hazel-Atlas Glass Company.
 Knox Glass Associates, Inc.
 Maryland Glass Corporation.
 Obear-Nester Glass Company.
 Owens-Illinois Glass Company.
 Pierce Glass Company.
 F. E. Reed Glass Company.
 Swindell Brothers, Inc.
 Three Rivers Glass Company.
 Tygart Valley Glass Company.
 Whittall-Tatum Company (Armstrong Cork).
- [22] General Purpose Container Companies:
 Anchor-Hocking Glass Corporation.
 Ball Brothers Company.
 Brockway Glass Company.
 Buck Glass Company.
 Carr-Lowrey Glass Company.
 Diamond Glass Company.
 Fairmount Glass Works, Inc.
 Florida Glass Manufacturing Company.
 Gayner Glass Works.
 Glenshaw Glass Company.
 Hart Glass Manufacturing Company.
 Hazel-Atlas Glass Company.
 Knox Glass Associates, Inc.
 Maryland Glass Corporation.
 Obear-Nester Glass Company.
 Owens-Illinois Glass Company.
 Pierce Glass Company.
 F. E. Reed Glass Company.
 Sterling Glass Company.
 Three Rivers Glass Company.
 Tygart Valley Glass Company.
 Whittall-Tatum Company (Armstrong Cork).

Milk Bottle Companies:

Buck Glass Company.
 Florida Glass Manufacturing Company.
 J. T. & A. Hamilton Company.
 Lamb Glass Company.
 Liberty Glass Company.
 Owens-Illinois Glass Company.
 F. E. Reed Glass Company.
 Thatcher Manufacturing Company.
 Universal Glass Products Company.

Fruit Jar Companies:

Ball Brothers Company.
 Hazel-Atlas Glass Company.
 Owens-Illinois Glass Company.
 Alexander H. Kerr & Company.
 F. E. Reed Glass Company.

Jelly Glass Companies:

Ball Brothers Company.
 Hazel-Atlas Glass Company.
 Alexander H. Kerr & Company.

[23] COMPANIES PRODUCING AND SHIPPING EACH CLASS OF PRODUCTS DURING 1937**WEST COAST MANUFACTURERS****Narrow Neck Bottle Companies:**

Glass Containers, Inc.
 Hazel-Atlas Glass Company of Calif.
 Latchford Marble Glass Company.
 Maywood Glass Company.
 Northwestern Glass Company.
 Owens-Illinois Pacific Coast Co.

Wide Mouth Bottle Companies:

Glass Containers, Inc.
 Hazel-Atlas Glass Company of Calif.
 Latchford Marble Glass Company.
 Maywood Glass Company.
 Northwestern Glass Company.
 Owens-Illinois Pacific Coast Co.

Milk Bottles, Fruit & Jelly Glasses & Pressed Food Ware:

Hazel-Atlas Glass Company of Calif.
 Owens-Illinois Pacific Coast Co.

Pressure & Nonpressure Ware:

Glass Containers, Inc.
 Hazel-Atlas Glass Company of Calif.
 Latchford Marble Glass Company.
 Northwestern Glass Company.
 Owens-Illinois Pacific Coast Co.

Beer Bottle Companies:

Glass Containers, Inc.
 Hazel-Atlas Glass Company of Calif.
 Latchford Marble Glass Company.
 Northwestern Glass Company.
 Owens-Illinois Pacific Coast Co.

Wine Bottle Companies:

Glass Containers, Inc.
 Hazel-Atlas Glass Company of Calif.
 Latchford Marble Glass Company.
 Maywood Glass Company.
 Northwestern Glass Company.
 Owens-Illinois Pacific Coast Co.

Liquor Ware Companies:

Glass Containers, Inc.
 Hazel-Atlas Glass Company of Calif.
 Latchford Marble Glass Company.
 Maywood Glass Company.
 Northwestern Glass Company.
 Owens-Illinois Pacific Coast Co.

Medicinal & Toilet Preparation Companies:

Glass Containers, Inc.
 Hazel-Atlas Glass Company of Calif.
 Litchford Marble Glass Company.
 Maywood Glass Company.
 Northwestern Glass Company.
 Owens-Illinois Pacific Coast Co.

General Purpose Container Companies:

Glass Containers, Inc.
 Hazel-Atlas Glass Company of Calif.
 Maywood Glass Company.
 Owens-Illinois Pacific Coast Co.

[25] RELATIONSHIP OF SHIPMENTS TO CAPACITY SINCE 1928

The following chart shows the relationship of shipments to capacity in total number of gross since 1928.

SHIPMENTS

Shipments in gross, rather than production, have been selected for this study because production records are not available prior to 1932. It was found, by a study of the figures since 1932, for which production records are available, that shipments quite accurately reflect the production within a fiscal year period.

CAPACITY

The capacity for the industry has been computed by using a mathematical formula for each plant. This capacity is divided into active and potential. Active capacity is considered as capacity actually operating, or capable of operating within a period of 30 days. Potential capacity is considered as capacity where major repairs are necessary, and which cannot be put into operation within the 30-day limit. On the chart, the potential capacity line is the total of active capacity, plus potential capacity, and equals the total capacity for the industry.

The melting area of a glass furnace determines quite accurately the amount of glass that can be produced by the glass furnace each day. In 1928 good operating furnaces were producing a ton of packed glass from 12 sq. ft. of melting area. Through improvement in tank design, better methods of firing, and generally improved efficiency in tank operation, this has been reduced so that currently good operating tanks are producing a ton of packed glass from 8 sq. ft. of melting area. This change has not been abrupt, but rather has been a steady and constant improvement each year.

It may be noted that some furnaces in the industry have, and are obtaining, a better performance than this, while other furnaces are not obtaining this performance. An average performance, would be impractical to obtain because many furnaces are not called upon for capacity operation. By this we mean that business is not sufficient to operate all of the equipment on the furnace, or to in many cases justify the expenditure for new and improved equipment.

The operation of many tanks in the industry proves that if the business were available, all tanks could meet the current capacity figure of a ton of glass for 8 sq. ft. of melting area.

The chart reflects the improvement yearly in the efficiency of glass furnaces from a ton of glass for 12 sq. ft. of melting area, to a ton of glass for 8 sq. ft. of melting area.

The working days per year are based on 280 days. This is arrived at by taking the total of 365 days, less 52 Sundays, less 5 [26] holidays, and less 28 working days for tank repairs, leaving a net of 280 working days per year. The operation is continuous, and the working day is 24 hours. While many glass furnaces operate for a longer period than the 280 days, it is conservative to calculate capacity on this basis. The number of gross for each company is computed by using the average weight bottle produced by that company.

ACTUAL PERFORMANCE DURING 1937

Following the charts on shipments and capacity, we show by tabulation the performance of individual companies against this capacity figure for the year 1937, and for the month of June, which was the peak production month during the year.

In the East, companies showing a low percentage of operation are companies that have specialized in certain classes of product, and have maintained a large capacity for peak periods of operation.

Some of these classes have become smaller, and others have shown very little growth, certainly not in proportion to the increase in capacity. (Refer to chart on shipments by classes of ware.) While the majority of these companies have started producing additional classes of product during the last two or three years, this additional production has not become sufficient to bring their operation near the industry average.

In the West the growth of business and of productive capacity have been very rapid. Construction of new capacity has not been in direct relationship to the increase in business. In 1936-37 two of the medium and small companies added new furnaces which more than doubled their capacity. Other companies are adding to their capacity in 1938.

Companies in the industry have been classified as large, medium, and small; 1928 was used for this classification. Large companies are defined as those that shipped 1,000,000 gross or more in 1928. Medium-sized companies are defined as those that shipped between 200,000 and 1,000,000 gross in 1928. Small companies are defined as those that shipped less than 200,000 gross in 1928.

Individual company identity has not been disclosed because of the confidential nature of the information.

[29] PERCENTAGE OPERATION POUNDS PRODUCED TO CAPACITY FOR 1937 (CAPACITY BASED ON 8 SQUARE FEET OF ACTIVE MELTING AREA PER TON PACKED) EAST OF ROCKY MOUNTAINS

	Year 1937	June 1937		Year 1937	June 1937
Total Industry.....	71.2	80.9	Small Companies:		
Large Companies:			18.....		
1.....	78.8	89.9	19.....	99.6	107.9
2.....	73.9	90.4	20.....	91.2	111.6
3.....	78.7	95.9	21.....		
4.....	38.6	42.3	22.....	122.9	169.2
5.....	48.6	53.0	23.....		
Group percentage.....	69.8	80.8	24.....	64.7	69.3
Medium Companies:			25.....	32.3	26.4
6.....	100.4	89.1	26.....	92.9	109.1
7.....	69.0	67.4	27.....	139.4	141.5
8.....	86.5	55.6	28.....	28.5	44.1
9.....	61.0	71.9	29.....	45.9	45.9
10.....	75.3	88.1	30.....	55.6	67.5
11.....	102.0	100.1	31.....	39.6	43.7
12.....	75.6	85.5	32.....	59.8	64.0
13.....	78.3	71.1	33.....	44.3	47.2
14.....	106.6	123.5	34.....	76.6	87.2
15.....	68.1	78.1	Group percentage.....	64.0	73.8
16.....	86.3	115.1			
17.....	70.9	92.5			
Group percentage.....	81.7	85.9			

[30] PERCENTAGE OPERATION POUNDS PRODUCED TO CAPACITY FOR 1937 (CAPACITY BASED ON 8 SQUARE FEET OF ACTIVE MELTING AREA PER TON PACKED) WEST COAST

	Year 1937	June 1937		Year 1937	June 1937
Total Industry.....	84.9	103.0	Medium & Small Companies:		
Large Companies:			W-3.....	70.5	108.5
W-1.....	87.7	109.7	W-4.....	84.7	83.4
W-2.....	124.5	144.1	W-5.....	35.2	33.0
Group percentage.....	95.3	116.8	W-6.....	51.1	68.0
			Group percentage.....	63.2	74.4

[31] PROGRESS OF INDIVIDUAL COMPANIES SINCE 1928

For this chart, individual companies are given a number so that confidential information will not be disclosed.

Companies in the industry have been classified as large, medium, and small; 1928 was used for this classification. Large companies are defined as those that shipped 1,000,000 gross or more in 1928. Medium-sized companies are defined as those that shipped between 200,000 and 1,000,000 gross in 1928. Small companies are defined as those that shipped less than 200,000 gross in 1928.

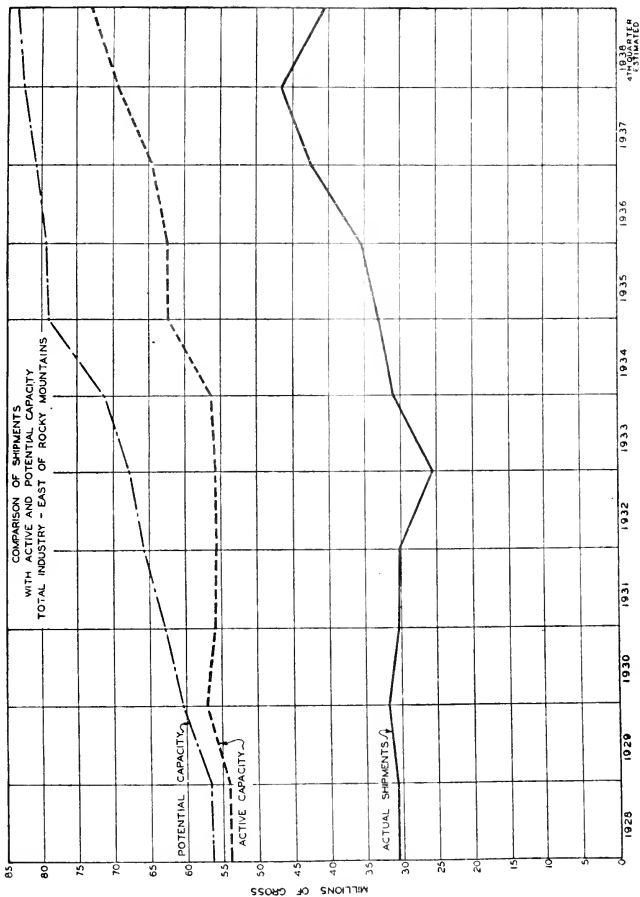

Shipments for each year since 1928 are related to the base year. The percentage of increase or decrease from this base year is shown on the chart. With this percentage as an index number, the progress of the individual companies is clearly shown.

For companies that have started since 1928, the second year of operation was taken as the base.

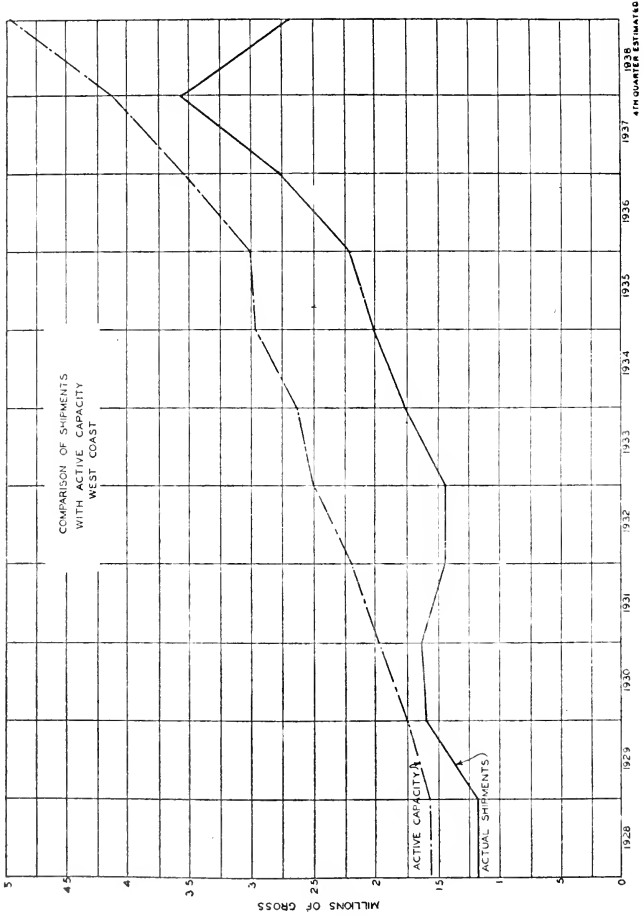

[32] PROGRESS OF INDIVIDUAL COMPANIES AND GROUPS, SHIPMENTS IN GROSS RELATED TO 1928 (EAST OF ROCKY MOUNTAINS)

	1928	1929	1930	1931	1932	1933	1934	1935	1936	1937
Total industry:										
Gross	30,745,309	32,163,053	30,264,260	30,031,566	25,541,258	31,274,360	32,988,087	35,408,394	42,779,928	46,811,107
Index	100.0	104.6	98.4	97.7	83.1	101.7	107.3	115.2	139.1	152.3
Large Companies:										
1.....	100.0	103.9	96.5	90.3	74.0	101.2	103.1	110.7	137.6	146.4
2.....	100.0	98.6	92.0	95.9	78.2	90.6	103.4	100.0	127.0	139.1
3.....	100.0	113.0	119.3	89.2	79.3	93.5	96.8	108.3	118.3	123.4
4.....	100.0	101.3	75.6	149.5	99.6	83.7	74.5	108.1	105.9	186.5
5.....	100.0	95.0	88.4	89.3	85.8	73.6	74.0	79.2	91.6	98.3
Group Index	100.0	103.2	97.2	94.0	77.6	95.1	99.2	104.9	128.2	140.1
Medium Companies:										
6.....	100.0	104.8	82.5	116.9	120.3	127.1	121.9	120.4	139.3	149.3
7.....	100.0	137.0	172.4	176.9	184.4	205.9	334.0	297.7	334.4	427.0
8.....	100.0	121.4	101.6	107.4	113.7	139.5	157.9	196.1	231.9	211.3
9.....	100.0	110.6	94.1	103.6	110.2	114.2	129.8	130.7	152.9	140.9
10.....	100.0	99.3	105.3	93.2	81.8	111.3	116.8	122.2	137.4	143.4
11.....	100.0	100.7	109.4	135.8	115.0	159.1	180.4	208.7	208.7	338.6
12.....	100.0	104.6	98.0	96.9	84.6	89.3	99.5	100.0	116.8	131.3
13.....	100.0	102.7	91.7	96.8	71.2	112.8	130.4	149.2	191.6	200.7
14.....	100.0	93.4	101.1	105.2	74.0	122.1	145.0	142.1	168.9	174.2
15.....	100.0	107.9	78.4	79.7	98.0	89.0	76.3	111.4	147.1	173.1
16.....	100.0	100.3	110.0	113.6	114.4	154.8	141.1	158.4	190.9	195.0
17.....	100.0	111.7	97.7	112.1	87.7	90.1	97.7	107.2	118.6	125.4
Group Index	100.0	107.0	99.9	109.4	100.1	122.4	132.5	145.3	174.5	189.5
Small Companies:										
18.....	100.0	97.0	119.8	111.5	71.7	102.6	23.1	171.0	205.7	229.3
19.....	100.0	119.9	113.2	124.3	107.6	109.6	166.3	130.5	194.5	254.0
20.....	100.0	104.3	101.5	66.1	45.9	81.9	118.3	130.5	194.5	254.0
21.....	100.0	113.6	167.4	133.6	8.4	9.9	1.1	228.7	190.4	223.9
22.....	100.0	115.1	81.4	82.7	105.6	161.1	169.1	228.7	190.4	223.9
23.....	100.0	75.5	49.9	27.1	14.4	12.6	6.0	92.8	93.9	315.3
24.....	100.0	124.2	113.9	103.7	88.7	106.4	114.7	102.1	317.1	352.4
25.....	100.0	90.0	64.8	53.0	43.4	40.9	40.8	274.0	378.6	478.6
26.....	100.0	151.6	152.3	159.5	114.3	184.0	233.1	328.5	327.0	371.6
27.....	100.0	146.1	136.0	169.1	177.3	227.6	265.3	126.3	109.0	116.1
28.....	100.0	118.5	98.0	133.7	131.3	112.8	109.1	105.9	118.9	118.9
29.....	100.0	94.5	93.2	83.0	95.4	93.9	95.4	105.9	118.9	118.9
30.....	100.0	100.0	89.1	73.3	58.4	111.3	114.2	128.0	180.0	197.2

For Companies Established In The Industry Since 1928 The Second Year's Operation Has Been Taken as 100.0.

PROGRESS OF INDIVIDUAL COMPANIES AND GROUPS, SHIPMENTS IN GROSS RELATED TO 1928 (EAST OF ROCKY MOUNTAINS)—Continued

	1928	1929	1930	1931	1932	1933	1934	1935	1936	1937
Small Companies—Continued.										
31.....	100.0	114.3	104.0	96.5	91.9	100.8	88.5	115.2	136.0	132.3
32.....	100.0	191.0	76.9	67.2	88.7	102.1	101.8	117.6	116.5	116.5
33.....	100.0	107.2	120.5	109.4	124.2	148.5	218.5	212.4	193.3	215.1
34.....	100.0	173.6	183.0	211.3	190.9	180.1	161.7	179.4	206.9	206.4
Group Index.....	100.0	113.8	108.6	106.5	97.3	119.2	129.1	147.1	164.1	186.1

[33] PROGRESS OF INDIVIDUAL COMPANIES AND GROUPS, SHIPMENTS IN GROSS RELATED TO 1928 (WEST COAST)

Total Industry:										
Gross.....	1,197,707	1,602,843	1,691,673	1,481,942	1,406,691	1,774,387	2,031,575	2,219,682	2,769,226	3,364,995
Index.....	100.0	134.0	141.0	124.0	117.0	148.0	170.0	185.0	231.0	281.0
Large Companies:										
W-1.....	100.0	135.0	127.0	94.0	80.0	97.0	105.0	115.0	141.0	166.0
W-2.....	100.0	135.0	68.0	100.0	111.0	150.0	190.0	210.0	281.0	351.0
Group Index.....	100.0	135.0	143.0	118.0	107.0	134.0	151.0	167.0	210.0	252.0
Small Companies:										
W-3.....	100.0	118.0	125.0	153.0	143.0	165.0	197.0	225.0	243.0	375.0
W-4.....	100.0	135.0	130.0	164.0	174.0	239.0	293.0	288.0	357.0	368.0
W-5.....	100.0	135.0	130.0	164.0	83.0	100.0	94.0	107.0	155.0	186.0
W-6.....	100.0	135.0	130.0	164.0	26.0	100.0	176.0	158.0	212.0	293.0
W-7.....	100.0	135.0	130.0	164.0	26.0	100.0	176.0	158.0	212.0	293.0
Group Index.....	100.0	125.0	127.0	157.0	185.0	239.0	286.0	303.0	366.0	465.0

For Companies Established In The Industry Since 1928 The Second Year's Operation Has Been Taken as 100.0.

[34] TREND OF PRICES IN THE GLASS CONTAINER INDUSTRY

The following chart shows the trend of prices in the Glass Container Industry as reported by the Bureau of Census. We believe this quite accurately reflects the general trend, though of course it does not permit an analysis of this trend by classification of product. The average size bottle during this period has remained practically constant, the maximum variation in weight being four pounds per gross. The average weight in 1932, the year prior to the manufacture of liquor bottles and beer bottles, showed an average weight per gross of 95.3 pounds. In 1937, including liquor and beer bottles, the average weight was 95.9 pounds per gross.

It should be noted that the popular demand for fancy shapes and designs has added materially to the value of certain lines. It should also be noted that within recent years many bottles are decorated with a permanent ceramic label or design, which has added materially to the value of the bottle. It should also be noted

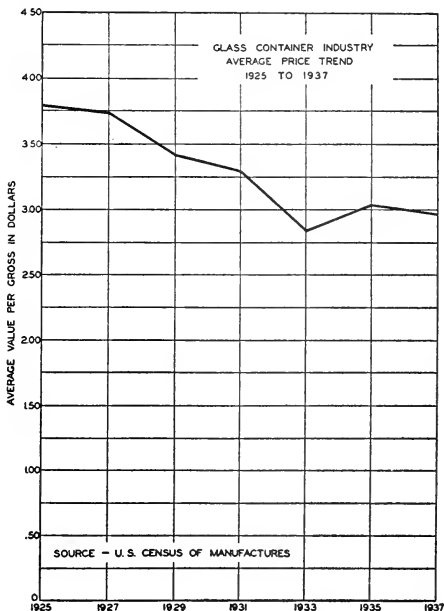

that in the earlier periods much of the glass in certain lines was shipped in bulk, or crates, with the customer providing his own package. At the present time these packages are supplied by the glass manufacturer. These added costs and services cannot be reflected in an over-all figure such as that given by the Bureau of Census.

REUSE CONTAINERS

There has been considerable public comment about the cost of beer bottles and milk bottles. The cost of these bottles per trip to the brewery, and to the dairy, may be stated as follows:

In 1935 the accounting firm of Touche, Niven & Co. made a study of costs for four representative breweries. Their report showed that the cost of beer bottles, and beer bottle cases, amounted to 1 and 77/100 cents per case of 24 bottles. This is a cost of \$0.00074 or seventy-four thousandths of a cent, for the use of each bottle and case per trip.

From a study made by the Department of Agriculture, milk bottles make an average of 34 trips. For the year 1937 the Census figures indicated a cost for milk bottles of \$5.33 per gross. This indicates that the cost of milk bottles to the dairy is \$0.00109 per bottle, or approximately 1/10 of a cent for each trip that a milk bottle makes.

[36]

EMPLOYMENT AND WAGES

The following charts showing employment and pay roll data quite clearly set forth the labor history of the industry since 1929.

We have related this labor data to volume of production, and to value of product, to measure employment during the period.

For illustration, in 1929, 27% employees produced 1,000 gross of bottles in one week. In 1937, 29% employees were required to produce 1,000 gross of bottles in one week.

The average labor cost per gross has increased approximately 13% during this period, while the average value of product has decreased approximately 13%.

Employment in the industry has been continuous, and without noted interruptions. Labor turn-over has been small, and few employees ever leave the industry. It is significant that the great majority of supervisors and executives have come from among the employees in the industry.

Labor in the industry has been organized for a great many years. Labor relations have been friendly and good. During this nine-year period strikes not authorized by the Union closed two individual plants for approximately one week. The Union authorized one strike that closed one plant approximately 3 days.

[37] GLASS-CONTAINER INDUSTRY—EMPLOYMENT AND PAY-ROLL DATA—TOTAL INDUSTRY EAST AND WEST COAST, 1929-1938

	1929	1930	1931	1932	1933
Factory Employees.....	17,173	17,390	16,493	14,713	14,919
Clerical Employees.....	823	781	796	786	742
Total Employees.....	17,996	18,171	17,289	15,499	15,661
Factory Payroll (\$) Per Week.....	429,722	443,701	400,442	326,808	296,569
Clerical Payroll (\$) Per Week.....	17,966	16,204	16,668	16,127	14,001
Total Payroll (\$) Per Week.....	447,688	459,905	417,110	342,935	310,570
Factory Hours Per Week.....	859,607	887,640	805,408	687,559	689,318
Clerical Hours Per Week.....	34,668	32,813	33,489	32,806	30,428
Total Hours Per Week.....	894,275	920,453	838,897	720,365	719,746
Average Hours Per Week Per Employee.....	49.7	50.6	48.5	46.5	46.0
Average Rate Per Hour Per Employee.....	50.1	50.0	49.7	47.6	43.1
Average Wage Per Week Per Employee.....	24.88	25.31	24.13	22.13	19.83
Gross Produced Per Average Week.....	1,649,344	1,614,537	1,606,029	510,887	645,129
Average Employees Per 1,000 Gross.....	27.7	29.6	28.5	30.3	24.3
Average Payroll Dollars Per Gross.....	.689	.748	.688	.671	.481

	1934	1935	1936	1937	1938
Factory Employees.....	21,647	23,080	25,293	28,231	26,103
Clerical Employees.....	1,080	1,299	1,571	1,736	1,617
Total Employees.....	22,727	24,379	26,864	29,967	27,720
Factory Payroll (\$) Per Week.....	428,147	481,950	572,804	729,844	708,504
Clerical Payroll (\$) Per Week.....	23,929	28,821	55,038	61,966	57,804
Total Payroll (\$) Per Week.....	452,076	510,771	627,842	791,810	766,308
Factory Hours Per Week.....	812,374	849,249	1,031,866	1,157,832	1,012,611
Clerical Hours Per Week.....	42,499	50,395	63,357	70,078	65,501
Total Hours Per Week.....	854,873	899,644	1,095,253	1,227,910	1,078,112
Average Hours Per Week Per Employee.....	37.6	36.9	40.8	41.0	38.9
Average Rate Per Hour Per Employee.....	52.9	56.8	57.3	64.5	71.1
Average Wage Per Week Per Employee.....	19.89	20.95	23.37	26.42	27.64
Gross Produced Per Average Week.....	688,129	745,073	871,028	1,017,977	1,800,525
Average Employees Per 1,000 Gross.....	33.0	32.7	30.8	29.4	34.6
Average Payroll Dollars Per Gross.....	.657	.686	.721	.778	.957

1 1929-31 Shipments, 1932-38 Production.

2 Based on 6 Months' Production.

GLASS CONTAINER INDUSTRY
 EMPLOYMENT AND PAYROLL DATA FOR ONE REPRESENTATIVE WEEK
 TOTAL INDUSTRY = EAST AND WEST COAST 1929 - 1938

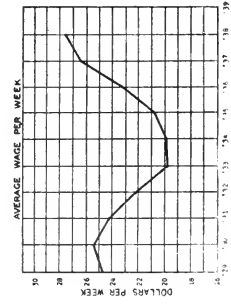
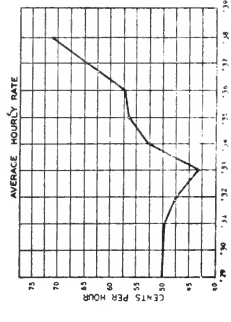
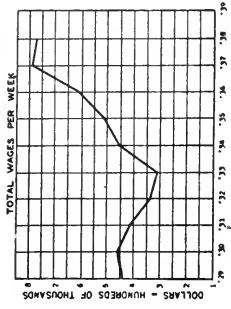
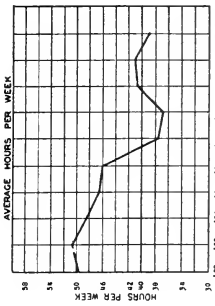
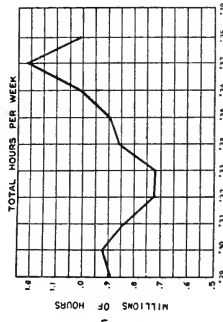
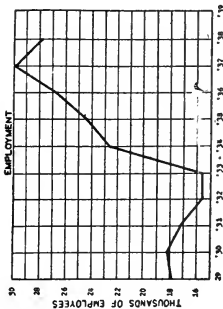

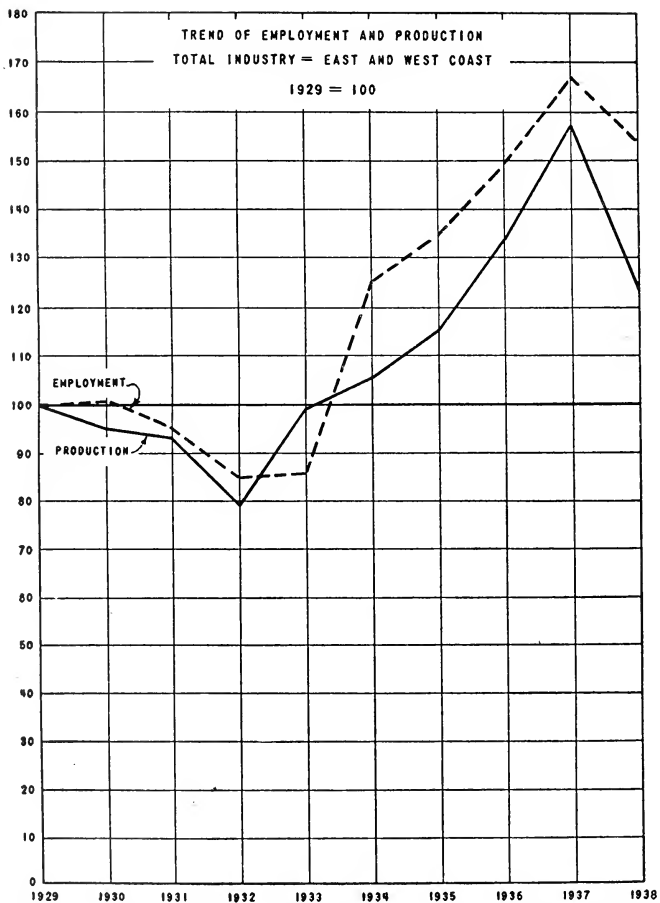

[40] AVERAGE VALUE PER GROSS RELATED TO WAGES—ENTIRE INDUSTRY—EAST AND WEST COAST

[1929=100]

	1929	1930	1931	1932	1933	1934	1935	1936	1937	1938
Average Value Per Gross †	3.41		3.30		2.85		3.04		2.96	
%-----	100.0		96.8		83.6		89.1		86.8	
Average Pay-roll Dollars per Gross	.689	0.748	.688	0.671	.481	0.657	.686	0.721	.778	1.0957
%-----	100.0	108.6	99.9	97.4	69.8	95.4	99.6	104.6	112.9	138.4

† U. S. Census Figures.

‡ Based on 6 month's production.

[42] THE GLASS CONTAINER ASSOCIATION ACTIVITIES

1. TRANSPORTATION

Through the Association, transportation of raw materials, containers, and packaged food products have been studied in detail. This has resulted in an equitable adjustment of freight rates, and a relationship of practically all freight rates in the industry to a definite railroad classification basis. The Association has supplied the railroad classification committees with information, also has represented the industry before the Interstate Commerce Commission.

The Association also, by presentation of facts to the railroads, and to the Interstate Commerce Commission, was instrumental in getting an equitable adjustment of freight rates on foods packed in glass.

The Association is recognized by the railroads, by the Classification Committee, and by the Interstate Commerce Commission as the representative of the Glass Container Industry. This relationship has resulted in a fair basis of rates equitably adjusted for every member of the industry.

2. STANDARDIZATION

Through the Association, finishes on glass bottles have been standardized and improved. It is now possible for manufacturers of glass, and manufacturers of caps and closures, to sell their products freely with the assurance that the package will be satisfactorily closed, and that there will be no difficulty for the packer, and no spoilage of product. This has been perfected so well that it is exceedingly rare that we have a complaint on spoilage even though the closures and glass are generally made by different manufacturers. Through this Committee, closures and finishes on glass have also been tremendously improved.

The Industry, through the Association, is now working on the standardization of many types of containers. The purpose of this effort is to redesign many of our standard lines so that:

- (1) They can be produced more efficiently and at lower cost.
- (2) They will be more acceptable to consumers. We believe that better standard designs at lower cost will attract more consumers to purchase glass packed products.
- (3) The standard containers can be produced on all types of equipment existing in the industry.

[43]

3. LABOR SURVEYS

The Association has made detailed labor surveys yearly showing hours of work, rates of pay, and working conditions. These have been very helpful in assisting the industry to develop better labor standards, and to clean up any bad conditions that existed in the industry.

4. STATISTICS

The Association has kept its members fully informed on factual data on production, shipments, capacity, and all other statistical information that will assist the individual manufacturer in operating his business intelligently.

5. TREASURY DEPARTMENT REGULATIONS

The Association has cooperated with the Alcohol Tax Unit of the Treasury Department in developing and policing regulations governing the marking of liquor bottles. This cooperation has meant that the regulations have worked smoothly, and without a single violation on the part of the glass manufacturers.

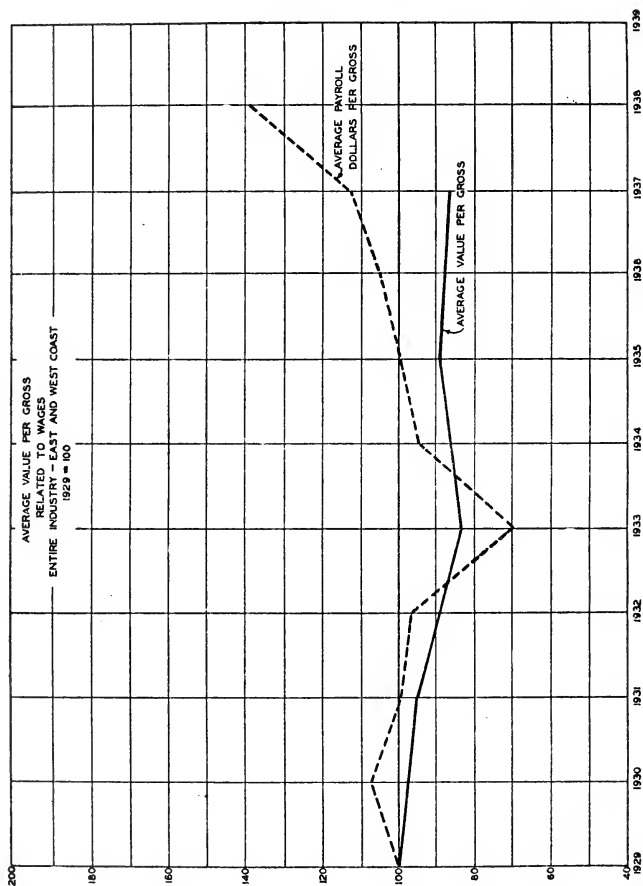

6. TECHNICAL RESEARCH ON GLASS PACKED PRODUCTS

The Association carried practically all of the technical packaging research until this work was taken over by members of the industry. This work was primarily the development of commercial packing in glass. It involved the development of equipment, and the development of a process for packing many of our food products. Since 1931 this work has largely been taken over by members of the

industry, though the Association continues to supervise special projects given to commercial laboratories on particular products which we believe can be satisfactorily packed in glass, or on which we believe the method of packing can be improved.

7. INDUSTRY TECHNICAL RESEARCH

Through the Association, the industry has developed a standard method for the testing of commercial glass. This has involved the improvement and the development of equipment, as well as the perfection of testing methods. This testing procedure enables all glass manufacturers to test containers on a uniform basis, and to be sure that all glass going to market is of good commercial quality. We believe that it will also have the effect of improving production methods, and will elevate the standards of commercial glassware.

8. ADVERTISING AND TRADE PROMOTION

Through the Association the industry has carried on an extensive advertising and promotion program. This has no doubt had the effect of increasing the use of glass packed products, and of [44] encouraging many packers to adopt the glass container as a package. This work has involved not only advertising but extensive market research. It also involves a Glass Kitchen which the industry sponsors to develop new foods, and new combinations of foods packed in glass.

9. TARIFF

The Association has represented the industry on all matters concerning tariff. This has included information supplied to the Appraiser's Stores, witnesses for the Tariff Court, facts for the Tariff Commission, and presentation of information to the Committee negotiating reciprocal agreements.

10. LAWSUITS INVOLVING BROKEN BOTTLES

A very considerable racket has grown up in claims involving broken bottles. Upon investigation it was found that probably 95% of these cases were fraudulent. The Association, through legal counsel and through technical experts, has been able to clean up the greater part of this racket. On legitimate cases the Association, through counsel and experts, has advised satisfactory settlement.

11. COSTS

The Association, after consultation with cost experts in the industry, has developed methods of cost finding which are probably the best available. These methods have been offered to the industry for voluntary acceptance.

12. The Association has represented the industry on matters concerning laws or regulations either municipal, state, or federal. For illustration, State Departments on Weights and Measures, Federal Pure Food and Drugs Act, Wage and Hour Bill, National Recovery Administration, etc. The Association has also kept the members informed on the operation of these regulations and laws, and to the best of our ability have advised the industry on proper conduct under them.

The following memorandum was submitted by Mr. Lawrence C. Kingsland under date of February 21, 1939, and was subsequently entered in the record as "Exhibit No. 431." It is printed at this point in connection with testimony herein, see text page 636.

EXHIBIT No. 431

MEMORANDUM OF SUGGESTED CHANGES IN THE PATENT LAWS

Telephone, Chestnut 6191

LAWRENCE C. KINGSLAND

COUNSELLOR AT LAW

705 Olive Street

ST. LOUIS, MISSOURI, February 21, 1939.

Edmund C. Rogers
Estill E. EzellHonorable JOSEPH C. O'MAHONEY,
Chairman, Temporary National Economic Committee,
Washington, D. C.

DEAR SIR: During my testimony before the Temporary National Economic Committee, as appears on page 534 of the Preliminary Print of the transcript of that testimony, I was requested by Senator King to send the Committee a memorandum setting forth my views as to what changes should be made in the present patent laws. At the same session, Honorable Thurman Arnold requested a memorandum in regard to the relationship of the patent laws and the anti-trust laws. This letter is in response to the request of the Committee, voiced by Senator King, as the subject inquired about by Mr. Arnold will be separately treated in another memorandum to the Anti-Trust Division of the Department of Justice.

At the outset, it is my view that it may be taken as granted that the fundamentals of our patent system are sound, and that, therefore, no changes should be made in the general policy expressed in the patent legislation. Therefore, any proposals in connection with the patent laws, *ipso facto*, take the direction of curing such evils as may exist in the administration of those laws. Certain evils are recognized as existing in the patent system in the form of abuse of laws that, in themselves, are not objectionable.

In a general way, the evils that do exist reside in the protection of monopolies beyond those reasonable monopolies that are the midway point between destruction of the rights of the public on the one hand, by absolutely uncontrolled patent monopolies, and utterly emasculated monopolies on the other hand that are insufficiently verile to stimulate inventive effort. In other words, that intermediate monopoly, which is the *desideratum* of the statute, is one that at once adequately promotes the arts and useful sciences and yet protects the public by assuring to it its share of the contract which is the proper enjoyment of the subject matter of patents.

At the outset, and after a full consideration of the subject, I am definitely opposed to the compulsory license. I feel that a compulsory license radically changes the effectiveness of the patent system under which American industry has been fostered and enlarged.

My first conclusion, therefore, is that this proposal does not present a solution of the problem and would be a radical change that would be detrimental to the general economy of the country that has been based upon the legal monopolistic principle of the absolute enjoyment for the limited period of years provided by the patent monopoly.

I have further reached the definite conclusion that a shortening of the term of the patent monopoly, except as it may be influenced by the initiation of the period of the monopoly by the application date, which I shall discuss hereinafter, should not be changed. I am convinced that the 17-year term of a patent is only a reasonable reward to the patentee for the disclosure of the invention to the public.

There are, however, several manifestations of the distortion of the time factor. Inventions, when disclosed, ordinarily go into public use and it is a clear abuse of the rights of the public for industry extraneously to develop around the public disclosure, only to be circumscribed after years of evolution, to which evolution the minds of the entire field have contributed improvements, by issuance at a late date of a basic patent dominating not only the original idea, but also the improvements. Under the later basic patent all are compelled to contribute for an interval of 17 additional years, during which time many of the improvement

patents may, in themselves, have expired. The owner of the improvement patents thus effectively loses their value, which should exist at least for the interval during which their lives continued after the expiration of the basic patent. In order to capitalize upon the improvement patents, their owner is virtually compelled to turn only to the owner of the fundamental patents and to deal with him on his own terms.

Furthermore, without injecting subsequent patents into the matter, a user who employs the published inventions during the interim years, perhaps completely innocent of the existence of any pending applications, suddenly finds himself ejected from a business he has built up after years of effort to a point where to stop it may mean destruction of the user's future business possibilities.

The remedy for this situation, in a measure would be accomplished, in my judgment, by a grant of the patent for a term of 17 years, or for the balance of a 20-year term dating from the application date, whichever is the shorter. This so-called "20-year term" proposal would avoid an unseasonable delay in the issue of a basic patent with a disturbing effect on industry, in some instances, many years after the application was filed. A procedure whereby a patent may issue on an application, in some cases as long as twenty to twenty-five years or more after the filing of an application, is definitely wrong; and, while it is true that there are not numerous instances of periods of twenty-years or more between the filing of the application and the issuance of the patent, there are sufficient of them to have a serious detrimental effect. Therefore, I would strongly favor the so-called "20-year term" proposal.

But, in adopting such a proposal, it must be recognized that certain injustices to the inventor may occur unless provision is made for reducing the normal prosecution of an application in all instances, in the Patent Office. The present requirement, that an applicant must respond to a Patent Office action within six months, has a tendency, so far as that prosecution is under the control of the applicant, to reduce the time of the pendency of the application. But the reduction in the time for the applicant to act upon the application alone does not solve the difficulty, as the historical facts show that the reduction of this period from two years to one year and finally to six months does not prevent, in some instances, a long delay between the filing of the application and the issue of the patent.

I feel that there would not be any injustice to an applicant if the period was further reduced from the present six months period to a three months' period, providing there was a reciprocal provision that the Patent Office response be limited to a corresponding period. In many cases the Patent Office actions occur within a three months' period, whereas, in other instances, longer delays than six months in the Patent Office exist. I have no doubt with the present personnel of the Patent Office that the application work is handled as expeditiously as possible, but there is no question that the period of prosecution in many instances is increased by reason of delayed actions by the Patent Office itself.

Without doubt, the interference proceeding in its present complicated form is the major cause for delay in prosecution of applications beyond a reasonable period of pendency. Numerous suggestions have been made with respect to a complete revision of the interference proceeding. It is an extremely difficult problem to solve.

There have been several methods of approach suggested:

1. The total abolishment of interferences;
2. A substitution of an opposition practice; and
3. A simplification of the present interference proceeding.

It is my view that the first solution is the only one that will effectively reduce the delay in the issue of the patent, but there remains the question as to whether this theory could be applied in practice without working an injustice in some instances.

Under this solution the patent would be issued to the first applicant; but some provision should be made for priority determination between a diligent applicant and the issued patent, lest injustices arise to the applicant.

The present interference practice, that depends upon depositions found so unsatisfactory as to become the exception in equity cases twenty-five years ago; and upon depositions of scattered witnesses; and with appeals to the Patent Office Board and even to the courts under Revised Statutes §§ 4911 and 4915, only then to result in inconclusive opinions short of *res adjudicata* and hence subject to retrial in the courts in later litigation, is extremely costly.

Since the statute now provides for interferences in the district courts by way of appeal under Revised Statute § 4915, *de novo* trials, and original actions between

interfering patents under Revised Statutes, § 4918, a similar procedure could be adopted in all interferences without introducing a judicial novelty.

I, therefore, suggest that interferences should, under restricted circumstances, be allowed, but determined by the District Courts in the jurisdiction of one of the parties. This cuts away the interference practice from the Patent Office, with its three potential reviews on appeal, and sends it at once to a court convenient to at least one of the parties, where it had two chances of ultimately going under old procedure, but then only after a costly and tedious prior determination in the Patent Office.

If the applicant was successful, his term should still be held to the "20-year term." Under the simplified federal court procedure priority issues should be promptly determined. Such action should be reviewable on appeal, and the decree in such suit should be *res adjudicata* as between the parties.

The solution of the problem has the merit of removing the primary cause for delay in prosecution of applications. It would safeguard the rights of the junior applicants, and it would eliminate the time and expense of presentation of the issue to the two tribunals in the Patent Office and on appeal to the Court of Customs and Patent Appeals that result in an inconclusive opinion.

In order that the junior applicants, having interfering applications pending in the Patent Office, upon the issue of the patent to the first applicant, may be notified of the existence of the interfering patent, provision should be made for a formal notice from the Commissioner of Patents of the issuance of the patent and of the common subject matter found by the Patent Office in the issued patent and the application, or applications, then in the Patent Office.

It is my view that the right to obtain a determination of the issue of priority by the courts should accrue only to applicants whose applications are filed within one year (or other limited time) of the filing date of the senior party whose patent has been granted; and also that there be a formal action by the Patent Office determining the question of the existence of common subject matter. The purpose of such provision is (a) to stimulate prompt filing of applications in the Patent Office (and, coupled with the 20-year term rule, prompt issuance of patents) and (b) to safeguard against setting up false interferences for purposes of delay where common subject matter does not, in fact, exist. The time within which priority actions may be instituted after such notice should be limited.

The second solution, namely, the substitution of an opposition proceeding for the present interference proceeding, particularly the plan proposed by the Advisory Committee to the Secretary of Commerce, has merit and, in my opinion, should receive consideration as a solution of the problem. My feeling, however, is that it would be time-consuming, perhaps to a lesser degree than the present practice but, nevertheless, to a degree sufficient to defeat the purpose of prompt issue of patents to the extent necessary to justify the "20-year term" proposal.

Under the third suggested solution, namely, simplification of the present interference practice, it seems almost hopeless to accomplish the elimination of delay. There are, of course, certain palliative measures that may be taken. Among these are the proposals of:

1. Eliminating one appeal in the Patent Office;
2. Abolishment of optional appeals to the Court of Customs and Patent Appeals or actions under § 4915;
3. Requirement for disclosure of invention dates when applications are filed, with proper provision for secrecy;
4. Limitations as to period of pendency of an application that may be declared in interference, i. e., a junior application filed over one year after the senior one, for example, may be denied the right to contest priority with a senior application;
5. Curtailment of preliminary motions; and,
6. Definite limitation as to time within which testimony must be taken.

Each of these proposals has merit, and would tend to reduce the delays due to the present practice, but they are inadequate, in my opinion, to correct the long pending application evil.

There are instances in which interferences are obtained by filing a reissue and involving another issued patent in a priority contest in the Patent Office. While this practice is not one that is directly connected with delay due to interferences, it does, in many instances, work an injustice because the patentee of an issued patent can be drawn back into the Patent Office and required to go through the complicated interference proceeding, and thus prevent him from enjoying the full effectiveness of his issued patent. Such practice accomplishes no useful purpose because the patentees, if there is in fact common subject, may contest

the question of priority either in infringement suits on the patent, or a suit for cancellation of the interfering patent. This type of interference is merely a waste of time and money because the Patent Office adjudication, under the present law, is not *res adjudicata* between the parties, and the whole gamut of court litigation is still available to either of the parties to the interference. This delay can be simply corrected by a provision that interferences shall not be declared under such circumstances.

In relation to delays of *ex parte* prosecutions, it is my view that the "20-year term" proposal would materially reduce delays chargeable to the applicant. A statutory change reducing the applicant's time for amendment to three months instead of six months would be helpful. Reciprocal provisions, that were discussed in connection with the "20-year term" proposal, *supra*, requiring promptness on the part of the Patent Office, would be necessary in order to assure prompt issue of the patent. Specifically, delays that result from renewing applications can be corrected by withdrawing the privilege of renewal after allowance, and the filing of continuations should not be permitted to extend the monopolies.

Divisional applications should be required to be filed within a limited time, not to exceed six months after requirement for division is made final. This probably requires right to interlocutory appeal on such requirements.

I am in favor of amendment of Revised Statutes, § 4886, to reduce the time period with respect to public use, public sale, and publication to one year. This would tend to promote prompt filing of applications after the completion of the invention, and yet secure to the inventor a sufficient time for testing the invention and for properly preparing and submitting the application.

I am clearly of the opinion that the situation growing out of the interpretation of the marking statutes by the Supreme Court in the *Wine v. Railway Appliance* decision should be corrected by legislation. Personally, I am in favor of denying to a patentee any recovery based on a constructive marking notice unless it be established that the infringer had notice or knowledge of the patent or wilfully infringed. In most instances no injustice is done by requiring the patentee to give written notice of alleged infringement.

If the marking statutes are to be retained as a basis of constructive notice, then clearly they should be revised, so that their benefits apply equally to all patentees, regardless of the nature of the invention, to correct the present situation where a process patentee is relieved from marking, as well as the owner of a paper patent, who has not made embodiments of the invention, whereas one making embodiments and failing to mark is denied recovery.

The foregoing has dealt mainly with Patent Office procedure looking to the prompt issue of a patent.

There is another delay that exists which arises out of the group ownership of patents, whereby such owner may protract litigation almost interminably by suing in sequence on various ones of the group of patents.

Examples exist of instances in which infringement of a large number of patents by the same structure is alleged, but the patents sued on one at a time. Termination of a suit on one is marked by the institution of another suit on other patents.

I am of the view that this condition can be remedied either through legislation or through the Rules of Civil Procedure by requiring that the plaintiff must sue on all of his available causes of action; that is to say, on all patents that are alleged to be infringed, in one suit; or, if he does not sue at the one time on all patents, he shall be barred thereafter to maintain action on any that are not brought into the suit. A related burden is put upon the defendant by the present rules.

Another possible solution of this evil of protracted litigation would be to require a patentee, as a basis of recovery, to give notice to an alleged infringer on all patents thought to be infringed and, if suit is instituted only on part of the patents included in the notice, then the defendant could have an election to counterclaim for declaratory judgment on the remainder under Rule 13. If this right was clearly fixed by legislation, it would be possible to clear the issue of infringement in a single suit and, if the charge of infringement is not well founded, not only the expense of the protracted litigation would be avoided, but the industry would be stabilized to an extent that it could safely expand its production without the hazard of belated establishment of infringement.

It is recognized that safeguards would have to be included to prevent the technical compliance with such provision by the transfer of patents at the time of notice.

There is another matter in connection with patent litigation that, in my opinion, requires drastic revision, and that is the question of accounting proceedings follow-

ing the interlocutory decree. The new rules of Civil Procedure have not met the situation as it applies to patent accountings, but, as this is a subject that requires specialized consideration and is not one that apparently has been raised so far by the testimony before this Committee, I see no purpose at the present time in making any detailed suggestions with respect thereto.

I quite realize that the foregoing suggestions are stated in rather general terms and that the technique of accomplishing the reforms embodying the principles of the suggestions will require quite detailed consideration. If there are any of the suggestions that the Committee would desire to have amplified, I shall be very glad to do so, if requested.

Very respectfully,

LAWRENCE C. KINGSLAND.

LCK:O.

INDEX

	Page
American Ball Bearing Co.....	309
Amsler-Morton Co.....	596-602
Anchor Hocking Glass Corporation.....	478, 554, 570-576, 649
License, cancelation.....	571-575
Antitrust Division, Department of Justice.....	253-254
Purpose.....	282, 377-378, 636
Antitrust laws.....	255, 377-378, 502-503, 556-557, 559
Arnold, Thurman, Assistant Attorney General.....	254-256
Arvedson, George C., chief of patent section, automobile manufacturers association.....	301
Association of Licensed Automobile Manufacturers.....	268-269, 271-272
Atlantic Bottle Co.....	524
Automobile Chamber of Commerce.....	286
Automobile Manufacturers' Association.....	268-269, 284-303, 312-313, 332, 335
Association fees.....	294
Cross-license.....	292
Cross-licensing, their policy.....	272
Purpose of membership.....	267, 285
Ball Bros. Co.....	405, 414, 441, 466, 516, 521, 551-595, 608, 612
Patents:	
License.....	553-554
Litigation.....	555
Royalties.....	560
Products, and percentage of total.....	551-552
Ball, Frank C., president, Ball Bros.....	551-595
Bantam Motor Car Co.....	294
Beech-Nut Packing Co.....	428
Belknap, Charles B., executive vice president, Owens-Illinois Glass Co.....	656-667
Berney-Bond Co.....	466
Borg-Warner Motor Co.....	366
Bracken, A. M., assistant treasurer and counsel, Ball Bros.....	551-560, 570-582
British Hartford-Empire Co.....	598
British Hartford-Fairmont Co.....	598
Buck Glass Co.....	404, 408
Carter, Henry W.....	455
Chance Bros. & Co., Ltd.....	659
Clerk, Sir Dugald.....	270
Coe, Conway P., Commissioner of Patents, United States Patent Office.....	372-374
Coleman, S. A., Jr.....	610-619
Collins, I. J., president, Anchor Hocking Glass Co.....	570-576
Corning Glass Works.....	401, 403-404, 442, 479, 484, 637-656
Corporations, average rate of income, 1926-35.....	610
Corporations, barred from filing patent applications.....	456
Cox, H. B., chief counsel, temporary national economic committee for Department of Justice.....	377-379
Cross-Licenses. <i>See</i> Patents.	
Curtiss, William H., vice president, Corning Glass Works.....	637-656
Day, George, Attorney at Law.....	619-624
Delco-Remy.....	371
Diesel, Rudolph.....	354
Dodge Brothers.....	294
Dorsey & Cole.....	436
du Pont.....	276
Electric Vehicle Co.....	271

	Page
Empire Machine Co.....	439, 638
European Verband Co.....	526
Falek, Alexander D., Chairman of the Board, Corning Glass Works.....	637-644
Farley, I. Joseph, patent counsel for Ford Motor Co.....	256-285
Patent laws, comment on and suggestions.....	265, 282-283
Fiat Co.....	662
Florida Glass Co.....	404-405, 421, 437, 453, 613
Ford, Edsel, President of Ford Motor Co. and Lincoln Motor Car Co.....	256, 285
Ford, Henry.....	347
Ford Motor Co.....	256-285, 303, 309, 312, 313, 331, 335, 347
Date of organization.....	268
Patents:	
License, number of.....	274
Licensing policy.....	268
Litigation, number won and lost.....	258
Litigation, yearly expense.....	277
Number owned.....	273
Policy regarding gratuitous use by other persons.....	257-258
Purpose for taking out patents.....	257
Fruit jar industry:	
Competition.....	575-576
Cut-rate products.....	579
Price, stabilization.....	578-579
Prices.....	577
Gayner Glass Works.....	554
Geer, Paul L., Treasurer, Amsler-Morton Co.....	596-602
General Electric Co.....	645-647, 654
General Motors Corporation.....	294, 328-376, 663
Capital investment.....	339
Date of organization.....	332
Employees, number.....	339
Patents:	
Cost of certain patents.....	366
License.....	362
Licensing policy.....	330, 333-337
Litigation, cost.....	335, 365
Litigations, number of.....	332, 335, 364-365
Purpose of taking out patents.....	329-330
Royalties.....	330, 336, 366-367
Research, policy.....	341-342
Research, yearly cost.....	332
Stockholders, number.....	339
Glass Container Association.....	403
Glass-container industry:	
Business failures, percentages.....	509
Equipment sold abroad.....	526
Exports and imports.....	431
Factory cost.....	507-509, 595
Failures, percentages.....	509
Feeders, types.....	441-442
Foreign glass market.....	525-526
Heat-resisting wares.....	401
Intercompany relations.....	383
Machines, cost of.....	506
Mechanical methods of production, history.....	526
New enterprises excluded because of patent monopoly.....	423
Output, yearly.....	533
Price decline.....	533
Price stabilization.....	415-416
Production, cost.....	506
Prohibition, effect of its repeal.....	609
Research, cost.....	507
Reuse containers, cost, etc.....	528
Substitutes for glass.....	533
T. N. E. C., scope of its immediate inquiry.....	379
Various products and their percentage of total.....	402-403

	Page
Glenshaw Glass Co.....	578
Goodrich, Edgar J., counsel for Hartford-Empire Co.....	395, 601, 602, 606, 667
Hart Glass Co.....	621
Hartford-Empire Co.....	379-490, 490-511, 516, 521-526, 536-545, 552-556, 561, 566-576, 578-662, 666
Assets, total sum.....	381
Delay of patent applications, comment.....	459
Employees, number.....	380
Inventions, their source.....	456
License.....	603-605
Patents:	
Applications, purpose.....	455
Foreign.....	430
License, certain restrictions.....	401-405, 417
License, fees.....	398-399, 427-428
License, revocation.....	571-575
Licensees, protection of.....	392
Licensing.....	383
Licensing, period of.....	392-393
Litigation.....	439-440
Litigation, policy regarding.....	443-445
Monopoly of certain kinds.....	381-383
Number owned.....	380
Protecting existing patent franchises.....	390-392
Purpose for taking out patents.....	386-387
Royalties.....	494-495
Royalties, income from.....	399
Royalties, percentage of total income.....	380-400
Specific.....	437-439, 468
Hartford-Fairmont.....	417-465
Hazel-Atlas Glass Co.....	401, 404-405, 437, 441, 463, 478, 481, 490, 497, 522, 536-549, 552-555, 560-576, 585, 594, 608, 610
Output, percentage.....	536
Patent license, cost.....	536
License, restrictions.....	562-567
Headley-Thompson.....	455-456
Houghton, Amory, president, Corning Glass Works.....	637-656
Houghton Associates.....	638-639
Hudson Motor Car Co.....	288
Illinois Glass Co.....	477-478
Indiana Glass Co.....	648-649
Injunctions, their use relative to patents.....	283
Inventions, patent system not responsible for.....	262-263, 332, 341-342
Jaspert, William B., Patent Attorney.....	596
Jeanette Glass Co.....	437
Justice, Department of, Anti-Trust Division.....	253-254
Purpose.....	282, 377-378
Kardo Corp.....	309, 362
Kearns-Gorsuch Co.....	437, 439, 522, 538
Kerr, Alexander.....	383
Kerr Glass Co.....	441, 573
Kettering, Charles F., vice president, General Motors Corp.....	340-361
Kimble Glass Co.....	478-479, 481
Kingsland, Lawrence C., patent attorney, Obear-Nester Glass Co.....	624-637
Knappe-Coleman Glass Co.....	610-619
Knox Glass Associates.....	582-595
Character and function.....	582-583
Knox Glass Bottle Co.....	586
Knudsen, William S., president, General Motors Corporation.....	328-340
Lamb Glass Co.....	404
Latchford Glass Co.....	408
Laurens Glass Works.....	406, 408
Levis, William E., president, Owens-Illinois Glass Co.....	474-535, 561
Directorships.....	481
Libbey Glass Co.....	442, 474, 525

	Page
Libbey-Owens-Ford Glass Co.....	376-377
Liberty Glass Co.....	504, 611, 614
Lincoln Motor Car Co.....	256, 273
Lucke, Professor.....	288
Lynch Corporation.....	524, 595, 599, 608, 633, 665
License.....	603-605
Macauley, Alvan, president, Packard Motor Car Co.....	304-313
Mandeville, William.....	480
Marienville Glass Co.....	583
Martin, E. F., assistant secretary and assistant treasurer, Owens-Illinois Glass Co.....	518-535
Maxwell Co.....	363
McCallister, E. W.....	464-473, 551-560, 570-582
McClure, Walter H., vice president and general sales manager, Hazel-Atlas Glass Co.....	536-549
McEvoy, James, director of patent section, General Motors Corporation.....	328, 340, 361-376
McFarlane Bill.....	278
McNash, J. H., president, Hazel-Atlas Glass Co.....	536-549, 561-576
Metro Glass Bottle Co.....	583
Miller Users' Defense Association.....	584-585
Patent litigation cost.....	585
Miller, William J., Engineering Co.....	522, 584-585
Modigliani.....	660, 662
National Cash Register Co.....	340
National City Bank of New York.....	610
Nivison-Weiskopf.....	439, 522
Northwestern Glass Co.....	506
Noyes, Judge.....	288
N. R. A. Code, etc.....	284
Obear-Nester Glass Co.....	437, 439, 522, 612-613, 619-620, 624-637
Products.....	625
Oil City Glass Bottle Co.....	583
Olean Glass Co.....	404, 479
Owens Bottle Co.....	375
Owens Corning Fiberglass Corporation.....	656-658
Owens European Bottle Co.....	526
Owens-Illinois Glass Co.....	382, 384, 401, 404-405, 411, 432, 474-549, 554-555, 560-561, 573, 599, 610, 623, 656, 667
Assets.....	474-475
Business, its nature.....	474
Licensing contract.....	491
Licensing, policy.....	517-519
Net worth.....	474
Origin.....	477-478
Output, percentage of total.....	474
Licensing, restrictions.....	502
Royalties.....	494
Royalties, policy regarding.....	499-502, 506-507
Research, cost.....	507
Owens-Illinois Pacific Coast Co.....	474
Owens Staple-Tied Brush Co.....	481
Packard Motor Car Co.....	305-328, 335, 366
Licensing policy.....	325
Number of patents owned.....	304
Patents, yearly income and expense.....	307
Parham, Sidney F., Patent Attorney, Hartford-Empire Co.....	396, 414, 436-464
Patent Laws:	
Comment on and suggested changes.....	265, 315-318
"History of the Growth of the Long Pending Patent Application Evil".....	374
Injunctions.....	283
Origin.....	318
"Proposed Patent Legislation".....	375
Purpose.....	298

Patent Office:	Page
Appeal from.....	440, 453
Appeal from, methods.....	324-325
Circuit Court of Appeals, their decisions not binding on.....	453
Decisions, percentage held valid.....	373
Decisions, their validity.....	453
Delay in issuing patents, suggested improvement.....	459-460
Interference proceedings, how initiated.....	452
Percentage of patents issued promptly.....	319
Practice and procedure.....	317-318, 372, 439, 440
Patents:	
Ancillary.....	560
Applications:	
"Applied for," its effect.....	449
Automobile, total number.....	302
Comment.....	449-450
Corporations barred from filing.....	456
Purpose.....	455
Basic, defined.....	444
Canadian system.....	278
Class B.....	288
Competition.....	451-462
Delay in issuing, suggested improvement.....	459-460
Effect on past development of industry.....	353
English system.....	278
European cartel system.....	425
"Fence in" defined.....	460
Fewer and better.....	282-283
Interference proceedings, how initiated.....	452
Inventions, patent system not responsible for.....	262-263, 332, 341-342
Laws. <i>See</i> Patent Laws.	
License.....	268, 272, 292, 362, 383
License, certain restrictions.....	401-405, 417
License, cost.....	612-613
License, exclusive.....	553-555
License, fees.....	398-399
License, limited.....	553-555
License, restrictions.....	562-567
Licensees, protection of.....	392
Licensees, right to sue.....	453-454
Licensing, compulsory.....	277-278
Licensing, compulsory, its effect on small companies.....	323-324
Licensing, its effect on the automobile industry.....	310
Licensing, policy.....	517-519
Licensing, restrictions.....	502
Licensing, restrictions on bringing suit.....	455-457
Life, formerly 14 years in U. S.....	326
Life in other countries.....	326
Life, suggested shorter period.....	318
Litigation, cost.....	277, 335, 365, 496, 585
Monopoly.....	256, 381, 383, 446
Non-use, legality.....	559
"Paper patents".....	265, 327-328, 387-388
Percentage issued promptly.....	319
"Petty," five year life.....	323
Protecting existing patent franchises.....	390-392, 450-452
Purpose of taking out patents.....	257, 327-329, 386-387
Research, effect on.....	453
Royalties.....	269, 307, 330, 335-336, 366-367, 380, 398, 399, 494-495, 449-502, 506-507, 542
Royalty fees.....	427-428
Royalty fees, purpose for charging.....	336
Small investors, their effect on.....	262
Specific.....	437-439, 465
Theory of.....	446-447
Use and abuse.....	255-256

	Page
Pease, A. M., assistant treasurer, Hartford-Empire Co.....	603
Peerless Motor Car Co.....	309
Peiler, Mr.....	389, 428, 462
Peiler Patent.....	437-440, 465, 627
Pennsylvania Bottle Co.....	58 ^c
Pennsylvania Sand Co.....	476
Pope-Hartford Co.....	269
Prohibition, effect of its repeal on Glass Container Industry.....	609
Pupin, Professor.....	288
"Pyrex".....	640, 648, 654
Reed Glass Co.....	437, 522, 573, 578
Reeves, Alfred, vice president and general manager, Automobile Manufacturers' Association.....	285, 303
Remy Bros.....	371
Royalties. <i>See</i> Patents.	
Safford, Arthur T., Jr., secretary and counsel, Hartford-Empire Co.....	379-433, 603-610
Salem Glass Works.....	554
Searcy.....	418
Selden case reported.....	270
Selden, George B.....	271
Selden patent, description.....	270
Shawkee Manufacturing Co. et al. v. Hartford-Empire Co.....	445
Sherman Anti-Trust Laws. <i>See</i> Anti-Trust Laws.	
Smith, F. Goodwin, president, Hartford Empire Co.....	379-433
Smith, Herbert Knox.....	386, 417, 433
Socony-Vacuum Oil Co., Inc.....	620
<i>Steimer case</i>	440-441
Steimer Patent.....	438-440, 565
Stookey Patent.....	628
Studebaker Co.....	292
Supreme Court decision, comment.....	265
Swindell Brothers.....	599
Thatcher Manufacturing Co.....	404, 478, 480, 590
Tibbetts, Milton, vice president and patent counsel, Packard Motor Car Co.....	304-328
Three Rivers Glass Co.....	418-419, 611-612
T. N. E. C.:	
Committee members present.....	252, 315, 377, 435, 489, 551, 603
Resolution under which committee will conduct hearings.....	253
Scope of examination of the glass industry.....	379
Toledo Glass Co.....	526
Tygart Valley Glass Co.....	543
Underwood, R. R., president, Knox Glass Associates.....	582-595
United States Glass Co.....	466, 468, 470
Universal Glass Products Co.....	404
Vestlake Machine Co.....	442, 526
Whitall Tatum Co.....	409-410, 428, 456, 524
Wightman Bottle & Glass Manufacturing Co.....	583
Williams, Lloyd T., general counsel, Owens-Illinois Glass Co.....	491-493, 495, 496, 521, 523, 526
Willitts, George H.....	375
Wine v. Enterprise.....	265
Winton Co.....	269

BOSTON PUBLIC LIBRARY



3 9999 06351 931 6

